

MMCX3300-9047

MMCX Plug Solder Right Angle
For .047 semi-rigid; 4GHz VSWR 1.2

50Ω

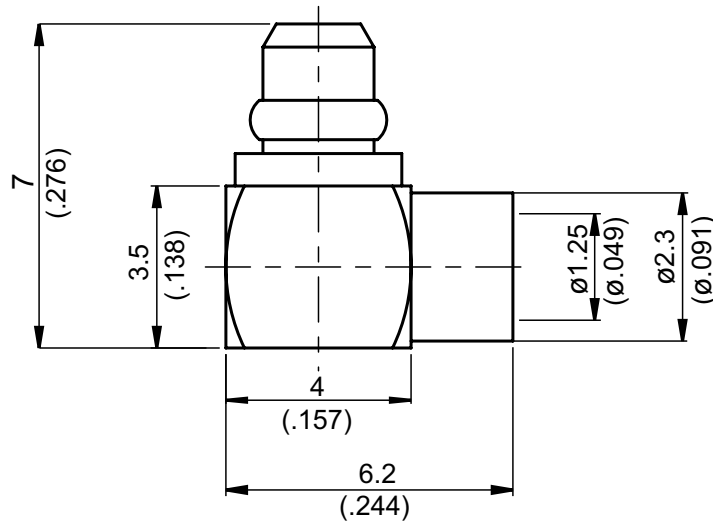

Parts	Material	Plating (Micro-inch)
Contact Pin	Brass	Gold 4 Over Nickel Phosphorous Alloy 80 Over Copper 20
Renber Ring	Beryllium Copper	Gold 4 Over Nickel Phosphorous Alloy 80 Over Copper 20
Barrel	Brass	Gold 4 Over Nickel Phosphorous Alloy 80 Over Copper 20
Insulator	Teflon	
Cover	Brass	Gold 4 Over Nickel Phosphorous Alloy 80 Over Copper 20
Barrel	Brass	Gold 4 Over Nickel Phosphorous Alloy 80 Over Copper 20

Suitable Cables: Semi-rigid.047

This part number complies with RoHS.



Notice: JYEBAO reserves the right to make modifications deemed appropriate.

MMCX	MMCX3300-9047																		
<div data-bbox="167 344 568 394" style="border: 1px solid black; padding: 2px;">Interface</div> <p data-bbox="167 400 368 434">IEC 61169-52</p>																			
<div data-bbox="167 510 568 560" style="border: 1px solid black; padding: 2px;">Electrical Data</div> <table border="0" data-bbox="167 566 1149 981"> <tr> <td>Impedance</td> <td>50Ω</td> </tr> <tr> <td>Frequency range</td> <td>DC to 4GHz</td> </tr> <tr> <td>VSWR</td> <td>≦ 1.2 (DC to 4GHz)</td> </tr> <tr> <td>Insertion loss</td> <td>≦ 0.05 x √f(GHz) dB</td> </tr> <tr> <td>Insulation resistance</td> <td>≧ 10000MΩ</td> </tr> <tr> <td>Contact resistance inner conductor</td> <td>≦ 5mΩ</td> </tr> <tr> <td>Contact resistance outer conductor</td> <td>≦ 2.5mΩ</td> </tr> <tr> <td>Dielectric withstanding voltage (at sea level)</td> <td>500 V rms</td> </tr> <tr> <td>Working Voltage (at sea level)</td> <td>170 V rms</td> </tr> </table>		Impedance	50Ω	Frequency range	DC to 4GHz	VSWR	≦ 1.2 (DC to 4GHz)	Insertion loss	≦ 0.05 x √f(GHz) dB	Insulation resistance	≧ 10000MΩ	Contact resistance inner conductor	≦ 5mΩ	Contact resistance outer conductor	≦ 2.5mΩ	Dielectric withstanding voltage (at sea level)	500 V rms	Working Voltage (at sea level)	170 V rms
Impedance	50Ω																		
Frequency range	DC to 4GHz																		
VSWR	≦ 1.2 (DC to 4GHz)																		
Insertion loss	≦ 0.05 x √f(GHz) dB																		
Insulation resistance	≧ 10000MΩ																		
Contact resistance inner conductor	≦ 5mΩ																		
Contact resistance outer conductor	≦ 2.5mΩ																		
Dielectric withstanding voltage (at sea level)	500 V rms																		
Working Voltage (at sea level)	170 V rms																		
<div data-bbox="167 1099 568 1149" style="border: 1px solid black; padding: 2px;">Mechanical Data</div> <table border="0" data-bbox="167 1155 1037 1335"> <tr> <td>Engagement force</td> <td>≦ 3.4 lbs</td> </tr> <tr> <td>Disengagement force</td> <td>1.4 to 3.4 lbs</td> </tr> <tr> <td>Contact captivation-axial</td> <td>≧ 2.3 lbs</td> </tr> <tr> <td>Durability (mating)</td> <td>≧ 500</td> </tr> </table>		Engagement force	≦ 3.4 lbs	Disengagement force	1.4 to 3.4 lbs	Contact captivation-axial	≧ 2.3 lbs	Durability (mating)	≧ 500										
Engagement force	≦ 3.4 lbs																		
Disengagement force	1.4 to 3.4 lbs																		
Contact captivation-axial	≧ 2.3 lbs																		
Durability (mating)	≧ 500																		
<div data-bbox="167 1406 568 1456" style="border: 1px solid black; padding: 2px;">Environmental Data</div> <table border="0" data-bbox="167 1462 1420 1688"> <tr> <td>Temperature range</td> <td>-65°C to +165°C</td> </tr> <tr> <td>Thermal shock</td> <td>MIL-STD-202, Method 107, Condition F</td> </tr> <tr> <td>Moisture resistance</td> <td>MIL-STD-202, Method 106</td> </tr> <tr> <td>Corrosion</td> <td>MIL-STD-202, Method 101, Condition B</td> </tr> <tr> <td>RoHS</td> <td>Compliant</td> </tr> </table>		Temperature range	-65°C to +165°C	Thermal shock	MIL-STD-202, Method 107, Condition F	Moisture resistance	MIL-STD-202, Method 106	Corrosion	MIL-STD-202, Method 101, Condition B	RoHS	Compliant								
Temperature range	-65°C to +165°C																		
Thermal shock	MIL-STD-202, Method 107, Condition F																		
Moisture resistance	MIL-STD-202, Method 106																		
Corrosion	MIL-STD-202, Method 101, Condition B																		
RoHS	Compliant																		
<div data-bbox="167 1760 568 1809" style="border: 1px solid black; padding: 2px;">Tooling</div> <table border="0" data-bbox="167 1816 957 1946"> <tr> <td>Locator tool</td> <td>ST-011</td> </tr> <tr> <td>Soldering fixture</td> <td>ST-008</td> </tr> <tr> <td>Insert for .047semi-rigid cable</td> <td>ST-047</td> </tr> </table>		Locator tool	ST-011	Soldering fixture	ST-008	Insert for .047semi-rigid cable	ST-047												
Locator tool	ST-011																		
Soldering fixture	ST-008																		
Insert for .047semi-rigid cable	ST-047																		

Notice: JYEBAO reserves the right to make modifications deemed appropriate.

JYE BAO CO., LTD.

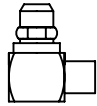
CABLE ASSEMBLY INSTRUCTION

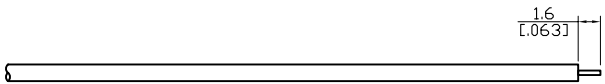
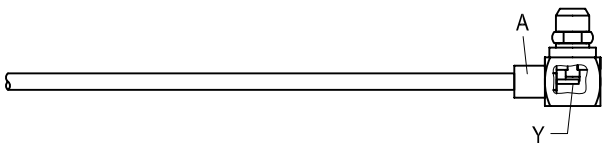
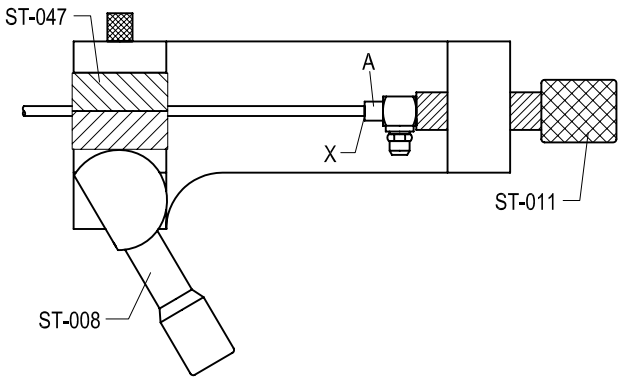
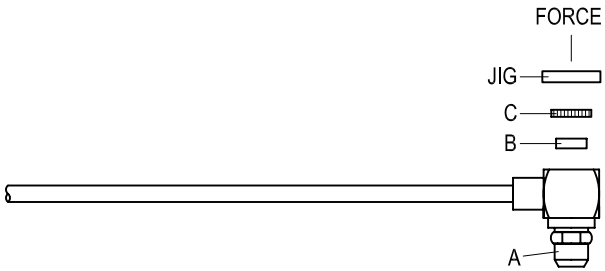
MMCX3300-9047	DATE	2017/10/20	REV	—
A	B	C		
				
BODY	INSULATOR	COVER		
DIAGRAM	ASSEMBLY INSTRUCTION			
	Step 1: STRIP AS SHOWN.			
	Step 2: SLIDE CENTER CONDUCTOR ON THE CONTACT PIN OF CONNECTOR " A " AND SOLDER IN " Y ".			
	Step 3: USE SOLDERING FIXTURE " ST-008 ", INSERT TOOL " ST-047 " AND LOCATOR TOOL " ST-011 " TO FIX THE CONNECTOR. SOLDER IN " X ".			
	Step 4: PRESS ON THE TOP OF " B " AND " C " WITH JIGS.			
<p>This part number complies with RoHS.</p> <p>Notice: JYEBAO reserves the right to make modifications deemed appropriate.</p>				
APPROVED	CHECKED	DRAWING	<i>Albert</i>	

MMCX3300-9047

S11

