

# BAL-0006SMG

## SURFACE-MOUNT BROADBAND BALUN

### DEVICE OVERVIEW

#### General Description

The BAL-0006SMG is a broadband surface mount balun, hand-tuned for optimal phase and amplitude balance over a 500 kHz to 6 GHz bandwidth. It serves as an excellent choice for analog to digital converters, balanced receivers, baseband digital modulations, and signal integrity enhancement.

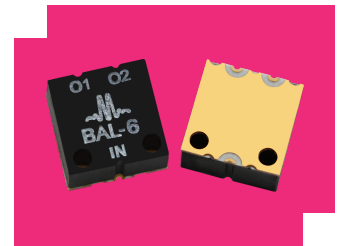

[Download s-parameters here](#)

#### Features

- 500 kHz to 6 GHz 1:2 Balun (Balanced to Unbalanced Transformer)
- Transforms 50  $\Omega$  Input to 100  $\Omega$  Differential (50 Ohm Single) Output
- Tuned for Optimal Phase/Amplitude Balance

#### Applications

- Balanced Receivers
- Analog to Digital Converters
- Baseband Digital Modulation
- Signal Integrity

#### Functional Block Diagram

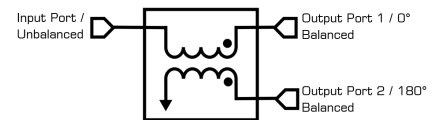

#### Part Ordering Options

Part Number	Description	Package	Green Status	Product Lifecycle	Export Classification
BAL-0006SMG	SURFACE-MOUNT BROADBAND BALUN	SMG	REACH RoHS	Released	EAR99
<u>EVAL-BAL-0006</u>	Evaluation Board, High Power 0.0005 - 6 GHz Broadband Balun	EVAL	Non-RoHS	Released	EAR99

## Table Of Contents

- **Device Overview**
  - General Description
  - Features
  - Applications
  - Functional Block Diagram
- **Port Configuration and Functions**
  - Port Functions
- **Revision History**
- **Specifications**
  - Package Information
  - Electrical Specifications
  - Time Domain Performance Plots
  - Mixed Mode Scattering Parameters
- **Mechanical Data**
  - Outline Drawing
- **Footprint Image**

## Revision History

Revision Code	Revision Date	Comment
-	2013-02-01	Datasheet initial Release
A	2019-03-01	Evaluation board outline added
B	2019-10-01	Mixed Mode Scattering Parameters added
C	2020-04-01	Unit Spread Graphs Added
D	2020-07-01	Update Specs table & low frequency Ssd21 plot added
E	2020-10-01	Update Specs table
F	2022-05-01	Max DC current update, Ground Plane Finish Update
G	2022-11-01	Banded Electrical Specifications Added
H	2023-12-21	Updated Specs table to add sub-banding on certain specifications.

## Port Configuration and Functions

### Port Functions

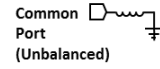
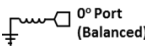
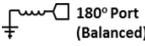
Port	Function	Description	Equivalent Circuit for Package
Common Port / In (Unbalanced)	RF Input	The common port is DC short to ground.	 <p>Common Port (Unbalanced)</p>
Out 1 / 0° Port (Balanced)	0° Port	The 0° port is DC short to ground.	 <p>0° Port (Balanced)</p>
Out 2 / 180° Port (Balanced)	180° Port	The 180° port is DC short to ground.	 <p>180° Port (Balanced)</p>

## Specifications

### Package Information

Parameter	Details	Rating
Dimensions	-	8.13 x 8.13 mm

## Electrical Specifications

Specifications guaranteed from -55 to +100°C, measured in a 50Ω system.

Parameter	Test Conditions	Minimum Frequency (GHz)	Maximum Frequency (GHz)	Min	Typ	Max	Unit
Insertion Loss as a Mode Converter	-	0.0005	0.002	-	3.9	-	dB
Insertion Loss as a Mode Converter	-	0.002	0.006	-	3.8	6.5	dB
Insertion Loss as a Mode Converter	-	0.006	6	-	4	5.5	dB
Nominal Phase Shift	-	0.0005	6	-	180	-	°
Amplitude Balance	-	0.0005	0.002	-	0.1	-	dB
Amplitude Balance	-	0.002	0.006	-	0.1	3	dB
Amplitude Balance	-	0.006	6	-	0.4	1.2	dB
Phase Balance	-	0.0005	0.002	-	0.9	-	°
Phase Balance	-	0.002	0.006	-	0.4	12	°
Phase Balance	-	0.006	6	-	3	10	°
Common Mode Rejection	-	0.0005	0.002	-	39	-	dB
Common Mode Rejection	-	0.002	0.006	16	45	-	dB
Common Mode Rejection	-	0.006	6	20	30	-	dB
Isolation	-	0.0005	6	-	8	-	dB
VSWR	-	0.0005	6	-	1.5	-	-
Risetime/Falltime <sup>1</sup>	-	0.0005	6	-	17	-	ps
Total Input Power	-	0.0005	6	-	-	1	W

<sup>[1]</sup> Specified as 90%/10%. Calculated from  $\tau_{\text{balun2}} = (\tau_{\text{out2}} - \tau_{\text{in2}})$

### Time Domain Performance Plots

Oscilloscope measurements of the BAL-0006SMG with a 6 Gb/s PRBS pattern. Bit pattern is measured with a 27-1 PRBS input demonstrating extremely good pulse fidelity for both inverted and non-inverted output. Eye diagrams are taken with a 231-1 PRBS input demonstrating minimal eye distortion/closure afforded by the extremely low frequency operation of the balun (<500 kHz).

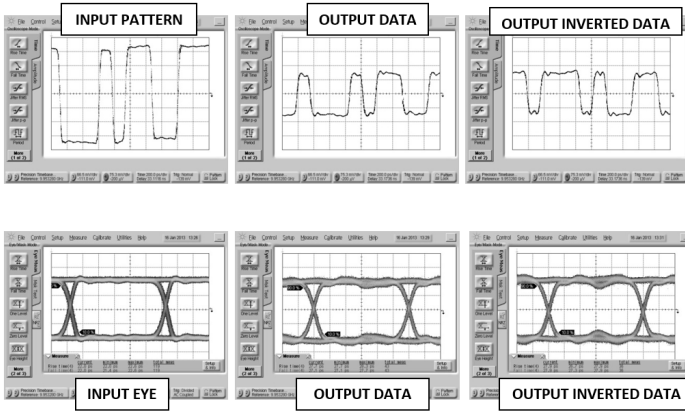

### Mixed Mode Scattering Parameters

Mixed mode scattering parameters are used to characterize differential circuits. For baluns, this means that the 0° and 180° ports become a single 100Ω differential port and the common port remains the same 50Ω common port. The two-port s-parameters of the balun are then characterized based on differential (d), common mode (c), or single-ended (s) signals. For example: Sds12 is the differential output response given a single ended input.

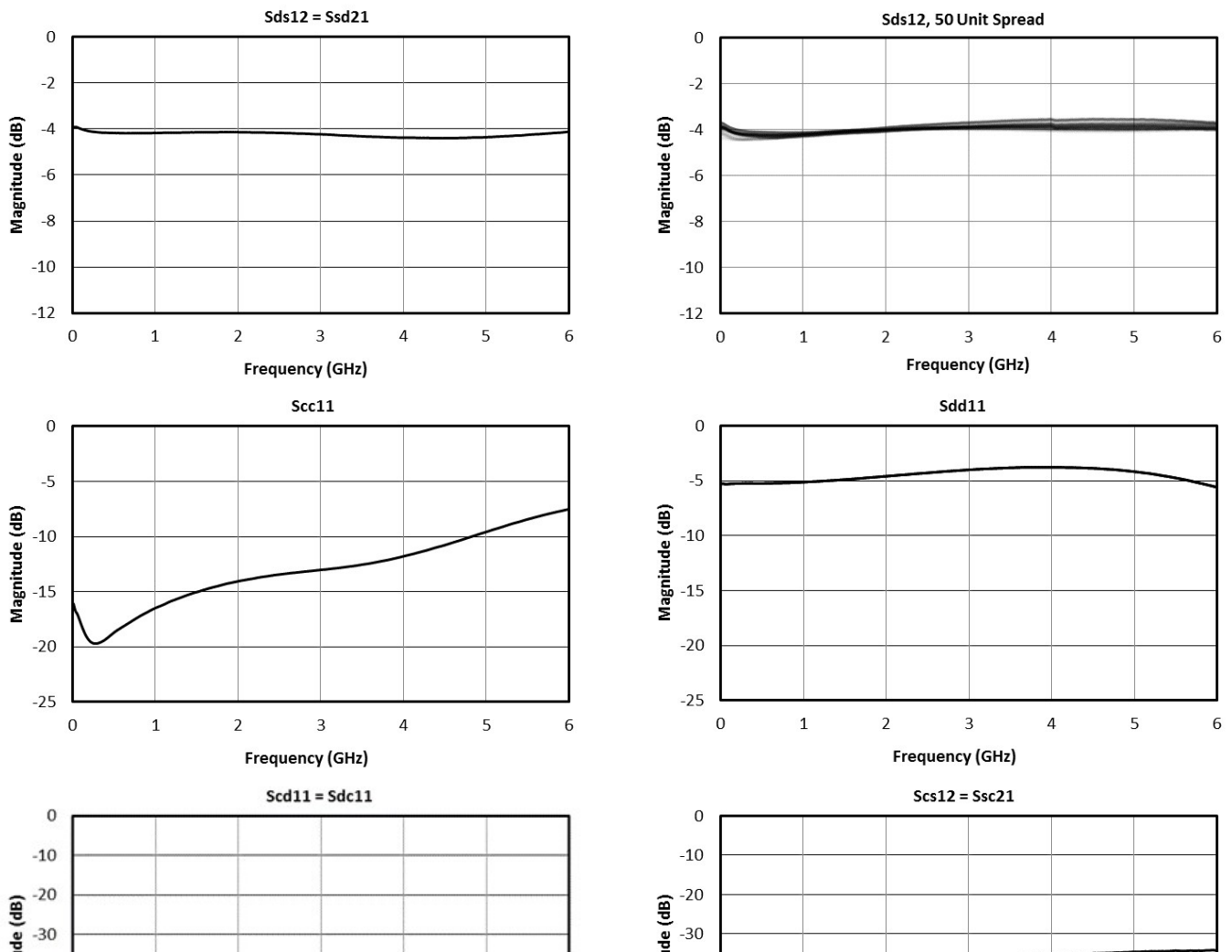

# BAL-0006SMG

## SURFACE-MOUNT BROADBAND BALUN

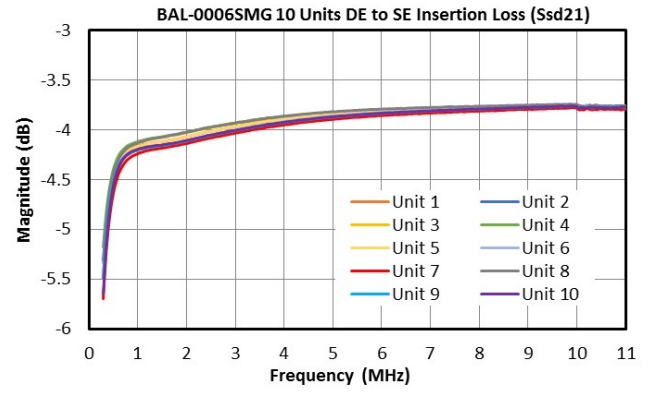
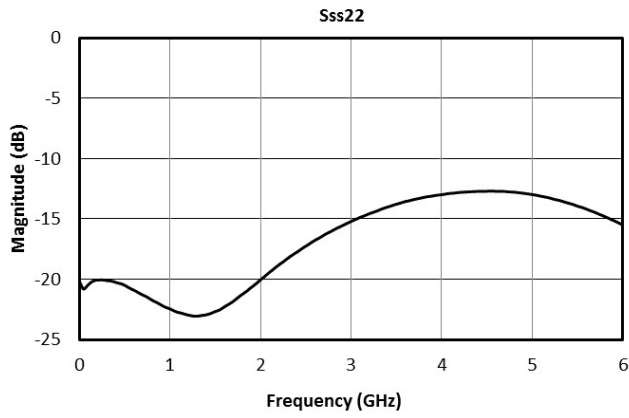

**Mechanical Data**

**Outline Drawing**

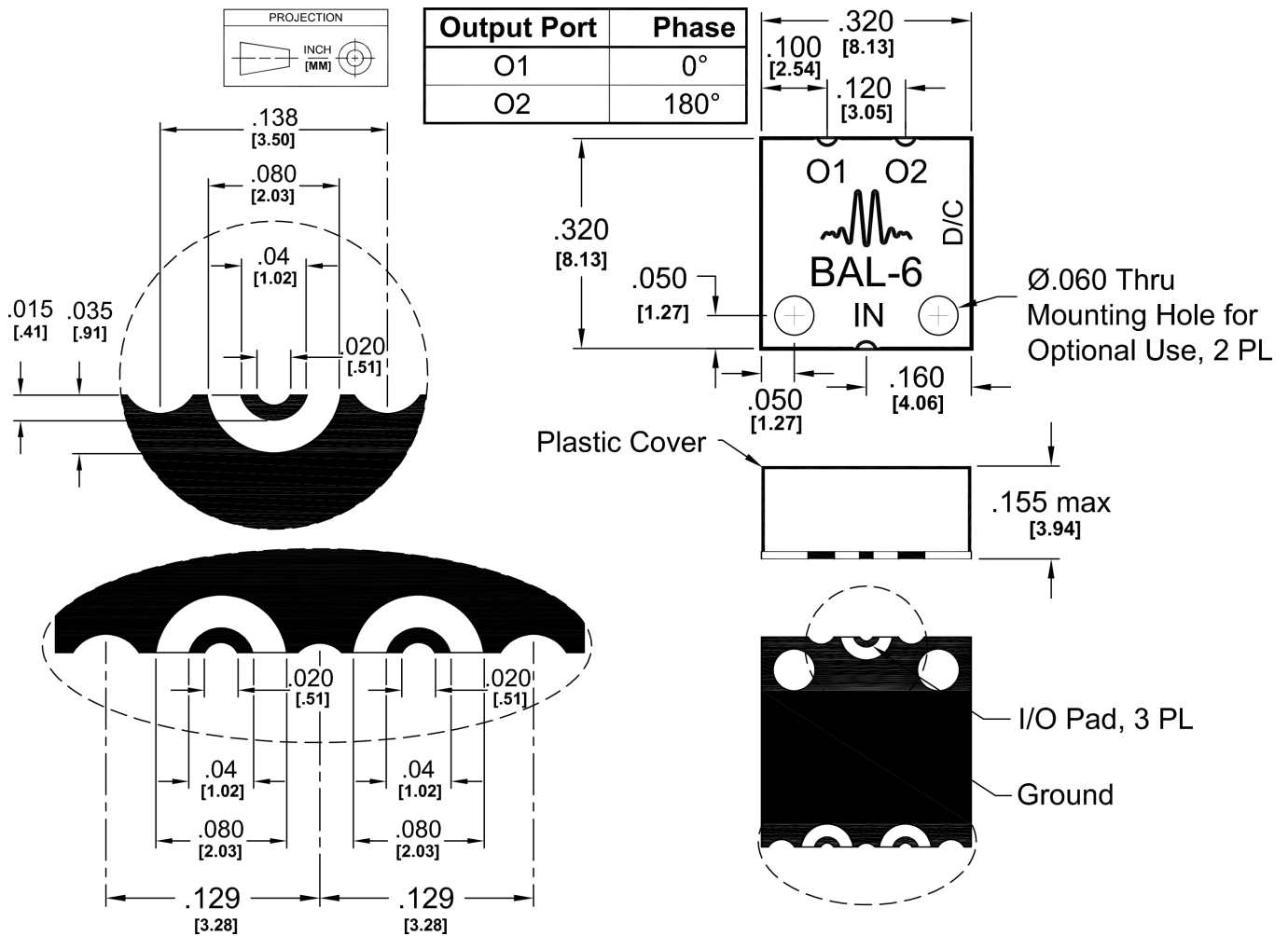

Substrate material is 8-mil thick Rogers 4003, 1 Oz Electrodeposited Cu. I/O Pads & Ground Plane Finish is Gold Flash, 5 to 10 μinches, over Electroplated Nickel, 100-200 μ-inches, over Cu.

Footprint Image

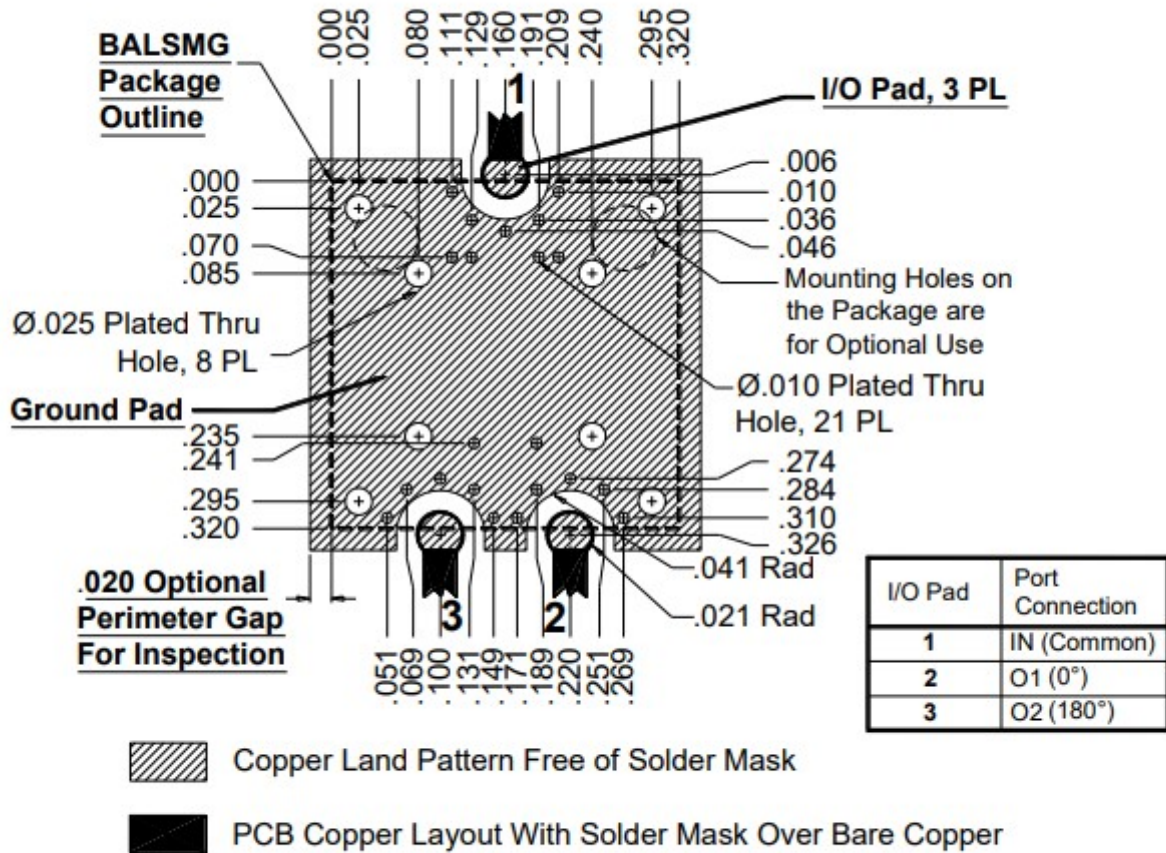

**Note:** Trace widths shown are for Rogers RO5880/Taconic TLY-5, .010" thick, 1/2 Oz copper. Widths may need to be modified for other materials.

## BAL-0006SMG

### SURFACE-MOUNT BROADBAND BALUN

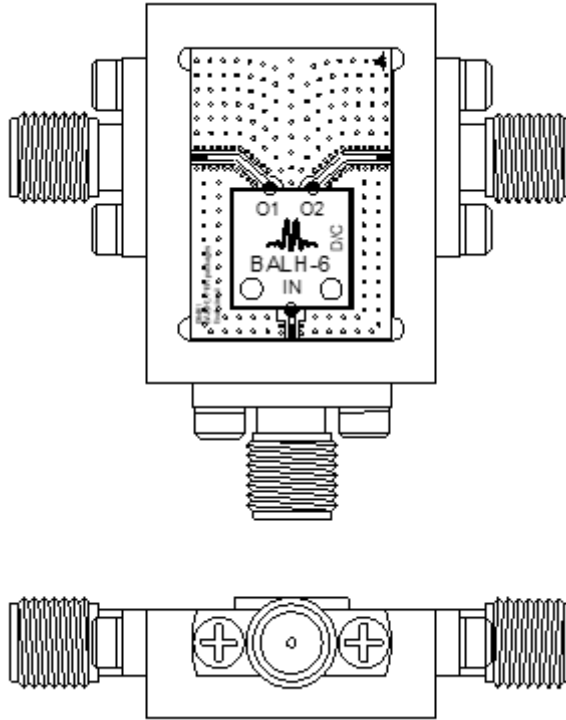

**DISCLAIMER**

MARKI MICROWAVE, INC., (“MARKI”) PROVIDES TECHNICAL SPECIFICATIONS AND DATA (INCLUDING DATASHEETS), APPLICATION OR OTHER DESIGN ADVICE, WEB TOOLS, AND OTHER INFORMATION AND RESOURCES “AS IS” AND WITH ALL FAULTS. MARKI DISCLAIMS ALL WARRANTIES, EXPRESS OR IMPLIED, INCLUDING, WITHOUT LIMITATION, ANY IMPLIED WARRANTIES OF MERCHANTABILITY, FITNESS FOR A PARTICULAR PURPOSE, OR NON-INFRINGEMENT.

These resources are intended for developers skilled in the art designing with Marki products. You are solely responsible for (1) selecting the appropriate products for your application, (2) designing, validating, and testing your application, and (3) ensuring your application meets applicable standards and other requirements. Marki makes no guarantee regarding the suitability of its products for any particular purpose, nor does Marki assume any liability whatsoever arising out of your use or application of any Marki product.

Marki grants you permission to use these resources only for development of an application that uses Marki products. Other reproduction or use of these resources is strictly prohibited. No license is granted to any other Marki intellectual property or to any third-party intellectual property. Marki reserves the right to make changes to the product(s) or information contained herein without notice.

MARKI MICROWAVE and T3 MIXER are trademarks or registered trademarks of Marki Microwave, Inc. All other trademarks used are the property of their respective owners.

© 2013, 2019 - 2020, 2022 - 2023, Marki Microwave, Inc