



SANYO Semiconductors

DATA SHEET

LA7848 — Monolithic Linear IC TV Vertical Output + E/W Driver with Bus Control Support

Overview

The LA7848 is a vertical deflection plus EW driver IC for high image quality TV and CRT displays that supports the use of a bus control system signal-processing IC. The sawtooth waveform from the bus control system signal-processing IC can directly drive the deflection yoke (including the DC component). The LA7848 also provides a parabolic waveform output that can similarly be used to drive the diode modulator block.

Functions

- Built-in pump-up circuit for low power dissipation.
- Vertical output circuit.
- Excellent crossover characteristics.

Specifications

Maximum Ratings at Ta = 25°C

Parameter	Symbol	Conditions	Ratings	Unit
Supply voltage	+B6 max		45	V
Output block supply voltage	+B3 max		92	V
Allowable power dissipation	Pd max	Mounted on an arbitrarily large heat sink.	9	W
Deflection output current	I2 max		-1.5 to +1.5	Ap-o
EW drive current *1	I10 max	V10 = 1.5V	+0.5	Ap-o
EW drive voltage *2	V10 max	I10 = 10μA	45	V
Thermal resistance	θj-c		4	°C/W
Operating temperature	Topr		-20 to +85	°C
Storage temperature	Tstg		-40 to +150	°C

Note: The EW driver is used within the range that connects the two points *1 and *2.

- Any and all SANYO Semiconductor products described or contained herein do not have specifications that can handle applications that require extremely high levels of reliability, such as life-support systems, aircraft's control systems, or other applications whose failure can be reasonably expected to result in serious physical and/or material damage. Consult with your SANYO Semiconductor representative nearest you before using any SANYO Semiconductor products described or contained herein in such applications.
- SANYO Semiconductor assumes no responsibility for equipment failures that result from using products at values that exceed, even momentarily, rated values (such as maximum ratings, operating condition ranges, or other parameters) listed in products specifications of any and all SANYO Semiconductor products described or contained herein.

SANYO Semiconductor Co., Ltd.

TOKYO OFFICE Tokyo Bldg., 1-10, 1 Chome, Ueno, Taito-ku, TOKYO, 110-8534 JAPAN

LA7848

Block Diagram

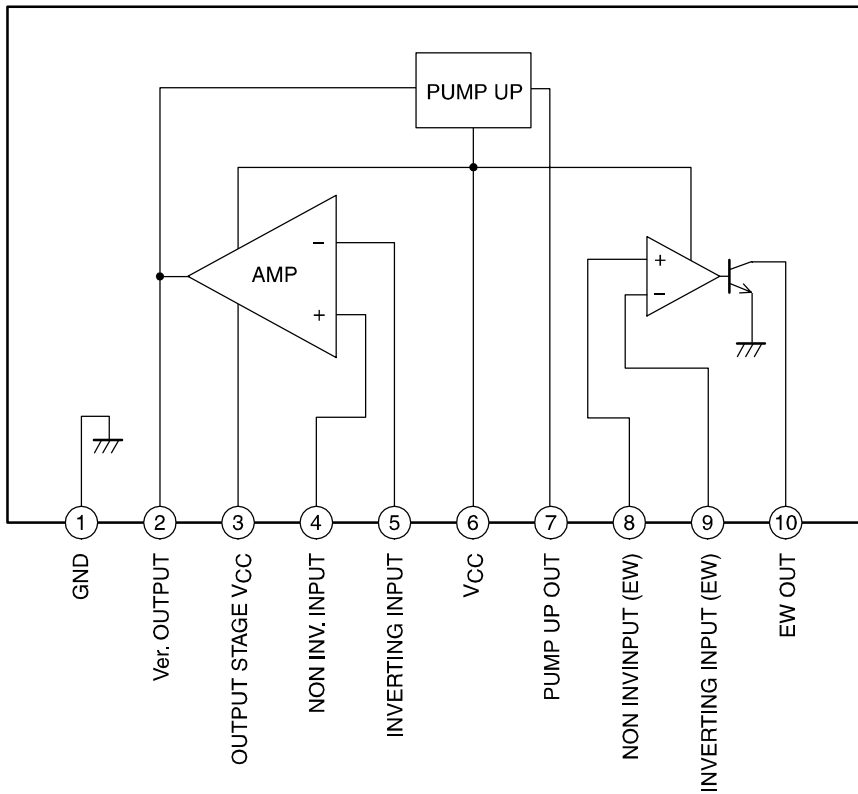

ILA07080

Test Circuit Diagrams

1. Output saturation voltage (lower) Vsat2-1

Figure 1

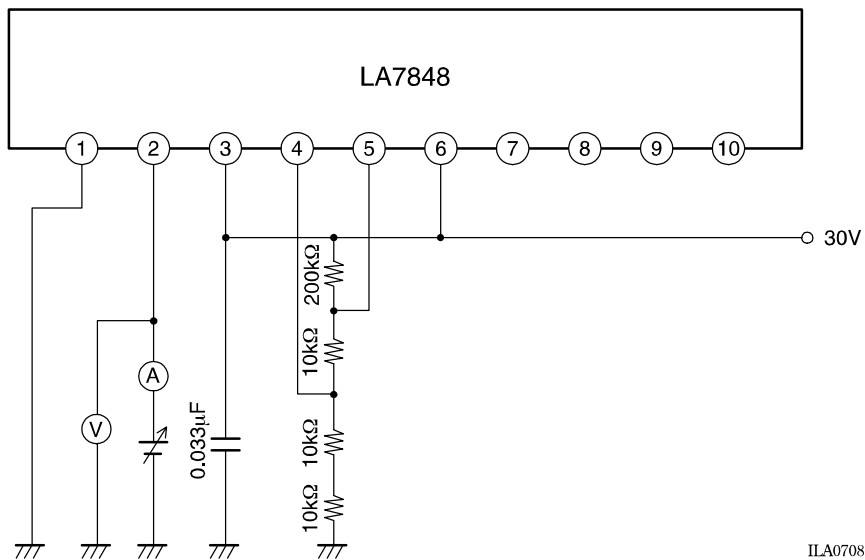

ILA07081

In the circuit in figure 1, read the value shown by the voltage meter (V) when the current meter (A) reads 1.1A.

LA7848

2. Output saturation voltage (upper) V_{sat3-2}

Figure 2

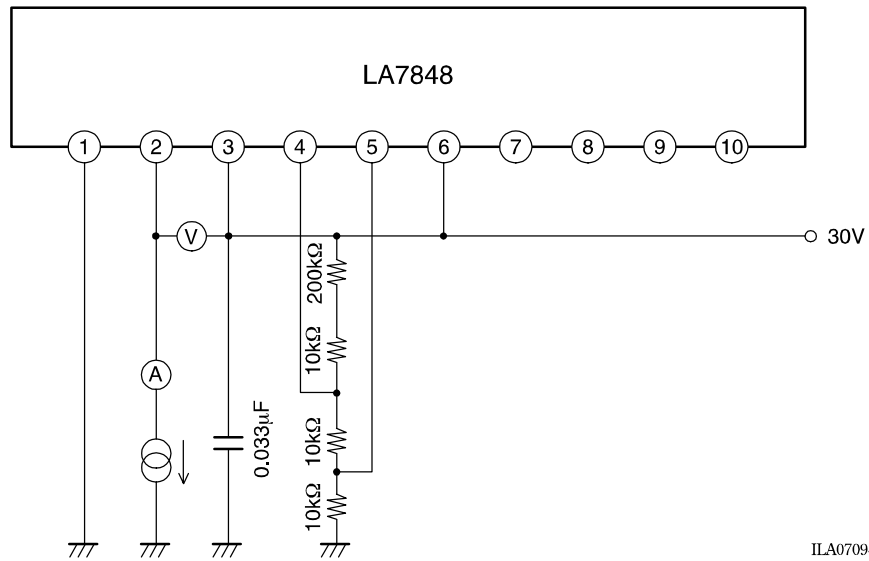

ILA07094

In the circuit in figure 2 with the output from pin 2 absorbed by an electronic load and read the value shown by the voltage meter (V) when the current meter (A) reads 1.1A.

3. Charge pump charge saturation voltage V_{sat7-1}

Figure 3

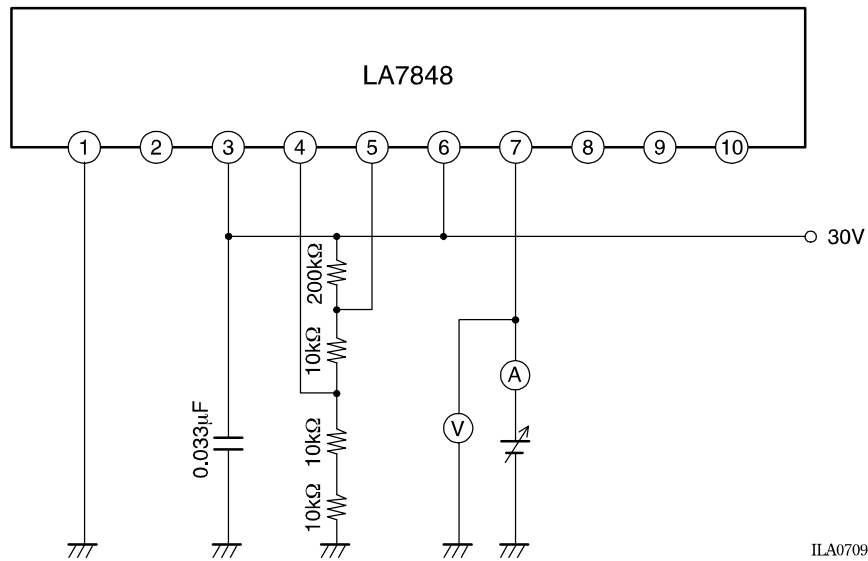

ILA07095

In the circuit in figure 3, read the value shown by the voltage meter (V) when the current meter (A) reads 20mA.

LA7848

4. Charge pump discharge saturation voltage V_{sat6-7}

Figure 4

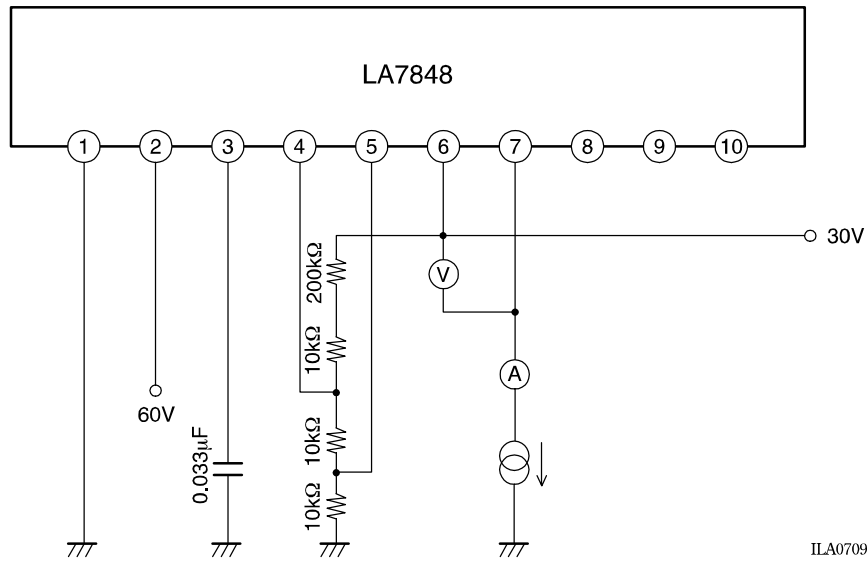

ILA07096

In the circuit in figure 4 with the output from pin 7 absorbed by an electronic load, read the value shown by the voltage meter (V) when the current meter (A) reads 1.1A.

7. Idling current I_{dl}

8. Midpoint voltage V_{mid}

Figure 5

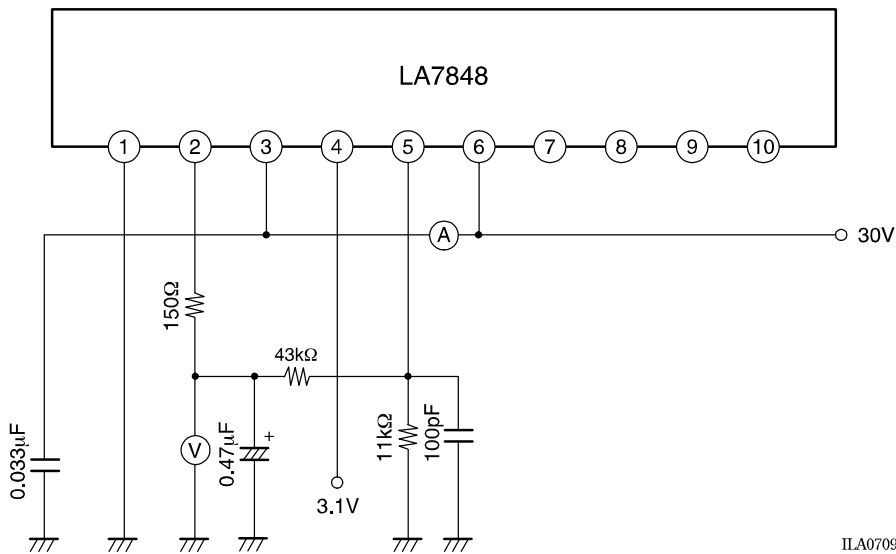

ILA07097

In the circuit in figure 5, read the value shown by the current meter (A).

In the circuit in figure 5, read the value shown by the voltage meter (V).

9. EW drive saturation voltage Vsat10-1

Figure 6

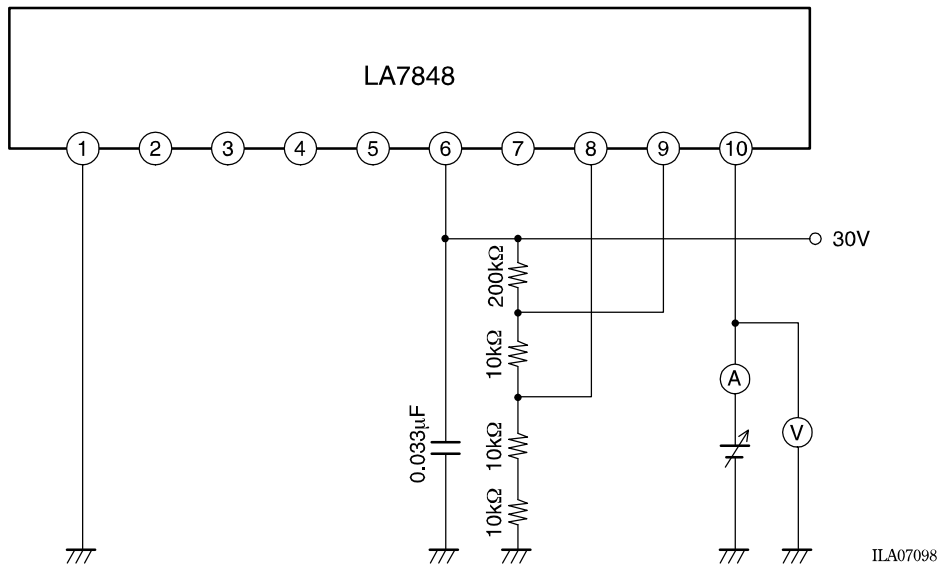

In the circuit in figure 6, read the value shown by the voltage meter (V) when the current meter (A) reads 500mA.

- Specifications of any and all SANYO Semiconductor products described or contained herein stipulate the performance, characteristics, and functions of the described products in the independent state, and are not guarantees of the performance, characteristics, and functions of the described products as mounted in the customer's products or equipment. To verify symptoms and states that cannot be evaluated in an independent device, the customer should always evaluate and test devices mounted in the customer's products or equipment.
- SANYO Semiconductor Co., Ltd. strives to supply high-quality high-reliability products. However, any and all semiconductor products fail with some probability. It is possible that these probabilistic failures could give rise to accidents or events that could endanger human lives, that could give rise to smoke or fire, or that could cause damage to other property. When designing equipment, adopt safety measures so that these kinds of accidents or events cannot occur. Such measures include but are not limited to protective circuits and error prevention circuits for safe design, redundant design, and structural design.
- In the event that any or all SANYO Semiconductor products (including technical data, services) described or contained herein are controlled under any of applicable local export control laws and regulations, such products must not be exported without obtaining the export license from the authorities concerned in accordance with the above law.
- No part of this publication may be reproduced or transmitted in any form or by any means, electronic or mechanical, including photocopying and recording, or any information storage or retrieval system, or otherwise, without the prior written permission of SANYO Semiconductor Co., Ltd.
- Any and all information described or contained herein are subject to change without notice due to product/technology improvement, etc. When designing equipment, refer to the "Delivery Specification" for the SANYO Semiconductor product that you intend to use.
- Information (including circuit diagrams and circuit parameters) herein is for example only; it is not guaranteed for volume production. SANYO Semiconductor believes information herein is accurate and reliable, but no guarantees are made or implied regarding its use or any infringements of intellectual property rights or other rights of third parties.

This catalog provides information as of September, 2005. Specifications and information herein are subject to change without notice.