

Description

The ICS1894-32 is a low-power, physical-layer device (PHY) that supports the ISO/IEC 10Base-T and 100Base-TX Carrier-Sense Multiple Access/Collision Detection (CSMA/CD) Ethernet standards, ISO/IEC 8802.3. It is intended for RMII/MII, Node/Repeater applications and includes the Auto-MDIX feature that automatically corrects crossover errors in plant wiring.

The ICS1894-32 incorporates Digital-Signal Processing (DSP) control in its Physical-Medium Dependent (PMD) sub-layer. As a result, it can transmit and receive data on unshielded twisted-pair (UTP) category 5 cables with attenuation in excess of 24 dB at 100MHz.

The ICS1894-32 provides a Serial-Management Interface for exchanging command and status information with a Station-Management (STA) entity. The ICS1894-32 Media-Dependent Interface (MDI) can be configured to provide either half-duplex or full-duplex operation at data rates of 10 Mb/s or 100Mb/s.

In addition, the ICS1894-32 includes a programmable LED and interrupt output function. The LED outputs can be configured through registers to indicate the occurrence of certain events such as LINK, COLLISION, ACTIVITY, etc. The purpose of the programmable interrupt output is to notify the PHY controller device immediately when a certain event happens instead of having the PHY controller continuously poll the PHY. The events that could be used to generate interrupts are: receiver error, Jabber, page received, parallel detect fault, link partner acknowledge, link status change, auto-negotiation complete, remote fault, collision, etc.

The ICS1894-32 has deep power modes that can result in significant power savings when the link is broken.

Applications: NIC cards, PC motherboards, switches, routers, DSL and cable modems, game machines, printers, network connected appliances, and industrial equipment.

Features

- Supports category 5 cables and above with attenuation in excess of 24dB at 100 MHz.
- Single-chip, fully integrated PHY provides PCS, PMA, PMD, and AUTONEG sub layers functions of IEEE standard.
- 10Base-T and 100Base-TX IEEE 8802.3 compliant
- MIIM (MDC/MDIO) management bus for PHY register configuration
- RMII interface support with external 50 MHz system clock
- Single 3.3V power supply
- Highly configurable, supports:
 - Media Independent Interface (MII)
 - Auto-Negotiation with Parallel detection
 - Node applications, managed or unmanaged
 - 10M or 100M full and half-duplex modes
 - Loopback mode for Diagnostic Functions
- Auto-MDI/MDIX crossover correction
- Low-power CMOS (typically 300 mW)
- Power-Down mode (typically 21mW)
- Clock and crystal supported in MII mode
- Programmable LEDs
- Interrupt output pin
- Fully integrated, DSP-based PMD includes:
 - Adaptive equalization and baseline-wander correction
 - Transmit wave shaping and stream cipher scrambler
 - MLT-3 encoder and NRZ/NRZI encoder
- Core power supply (3.3 V)
- 3.3 V/1.8 V VDDIO operation supported
- Smart power control with deep power down feature
- Available in 32-pin (5mm x 5mm) QFN package, Pb-free
- Available in Industrial Temp and Lead Free

Block Diagram

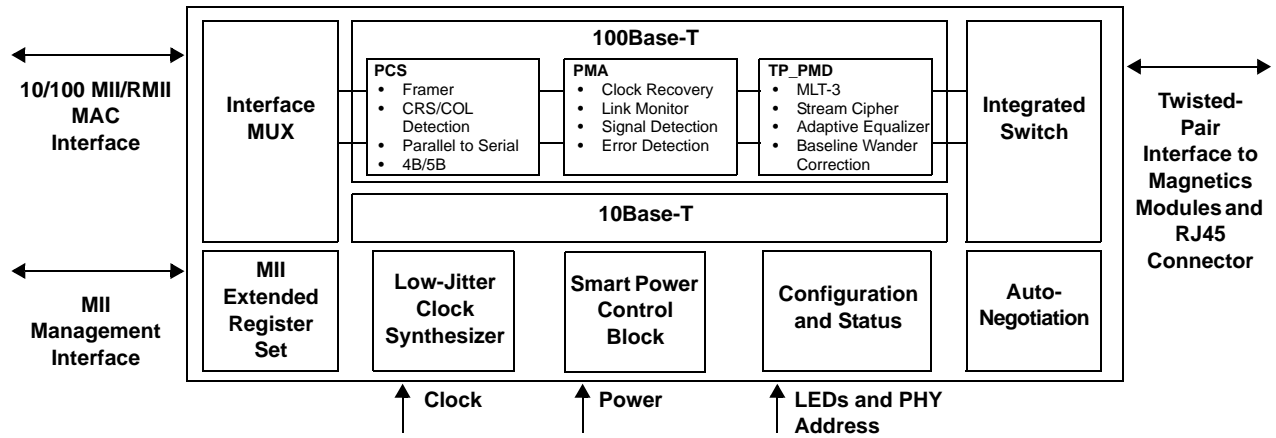

Pin Assignment

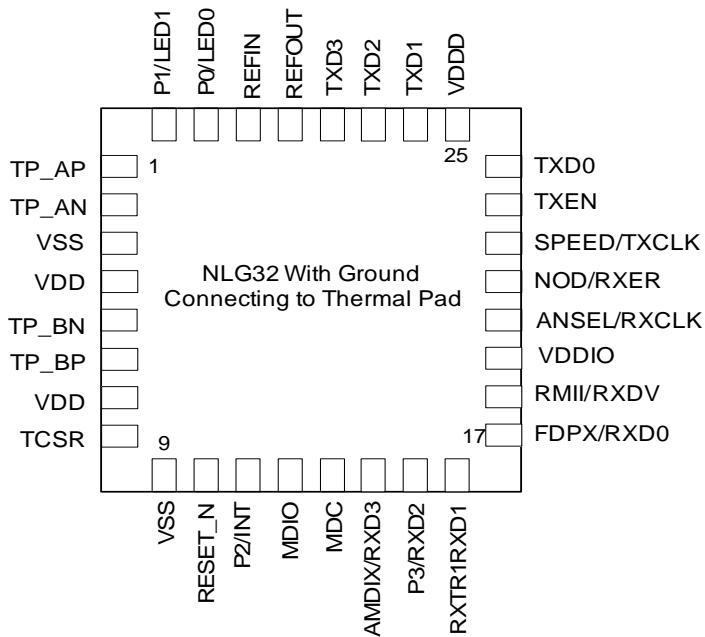

32-pin 5mm x 5mm QFN

Pin Descriptions

Pin Number	Pin Name	Pin Type ¹	Pin Description
1	TP_AP	AIO	Twisted pair port A (for either transmit or receive) positive signal
2	TP_AN	AIO	Twisted pair port A (for either transmit or receive) negative signal
3	VSS	Ground	Connect to ground.
4	VDD	Power	3.3V Power Supply
5	TP_BN	AIO	Twisted pair port B (for either transmit or receive) negative signal
6	TP_BP	AIO	Twisted pair port B (for either transmit or receive) positive signal
7	VDD	Power	3.3V Power Supply
8	TCSR	AIO	Transmit Current bias pin, connected to Vdd and ground via resistors (see “Recommended Component Values” table and the “ICS1894-32 TCSR” figure).
9	VSS	Ground	Connect to ground.
10	RESET_N	Input	Hardware reset for the entire chip (active low)
11	P2/INT	IO/lpd	PHY address Bit 2 as input (during power on reset/hardware reset) Interrupt output as output (default active low, can be programmed to active high)
12	MDIO	IO	Management Data Input/Output
13	MDC	Input	Management Data Clock
14	AMDIX/RXD3	IO/lpu	AMDIX enable as input (during power on reset/hardware reset) Receive data Bit 3 in MII mode as output.
15	P3/RXD2	IO/lpd	PHY address Bit 3 as input (during power on reset/hardware reset) Receive data Bit 2 in MII mode as output.
16	RXTRI/ RXD1	IO/lpu	RX tri-state enable as input (during power on reset/hardware reset) Receive data Bit 1 in both RMII and MII mode as output.
17	FDPX/ RXD0	IO/lpu	Full duplex enable as input (during power on reset/hardware reset) Receive data Bit 0 in both RMII and MII mode as output
18	RMII/RXDV	IO/lpd	RMII/MII select as input (during power on reset/hardware reset) Receive data valid in MII mode and CRS_DV in RMII mode as output.
19	VDDIO	Power	3.3 V/1.8 V IO Power Supply.
20	ANSEL/ RXCLK	IO/lpu	Auto-negotiation enable as input (during power on reset/hardware reset) Receive clock in MII mode as output.
21	NOD/ RXER	IO/lpd	Node/repeater select as input (during power on reset/hardware reset) Receive error in MII/RMII mode as output
22	SPEED/ TXCLK	IO/lpu	10M/100M select as input (during power on reset/hardware reset) Transmit clock in MII mode as output
23	TXEN	Input	Transmit enable in RMII/MII mode
24	TXD0	Input	Transmit data Bit 0 in RMII/MII mode
25	VDDD	Power	3.3 V Power Supply
26	TXD1	Input	Transmit data Bit 1 in RMII/MII mode
27	TXT2	Input	Transmit data Bit 2 in MII mode
28	TXD3	Input	Transmit data Bit 3 in MII mode

Pin Number	Pin Name	Pin Type ¹	Pin Description
29	REFOUT	Output	25 MHz crystal output, floating in RMII mode
30	REFIN	Input	25 MHz crystal (or clock) input in MII mode. 50 MHz clock input in RMII mode.
31	P0/LED0	IO	PHY address Bit 0 as input (during power on reset/hardware reset) and LED # 0 (function configurable, default is "activity/no activity") as output
32	P1/LED1	IO	PHY address Bit 1 as input (during power on reset/hardware reset) and LED # 1 (function configurable, default is "10/100 mode") as output
PADDLE	VSS	Ground	Connect to ground.

Notes:

- AIO: Analog input/output PAD.
IO: Digital input/output.
IN/lpu: Digital input with internal 20k pull-up.
IN/lpd: Digital input with internal 20k pull-down.
IO/lpu: Digital input/output with internal 20k pull-up.
IO/lpd: Digital input/output with internal 20k pull-down.
- MII Rx Mode: The RXD[3..0] bits are synchronous with RXCLK. When RXDV is asserted, RXD[3..0] presents valid data to MAC on the MII interface. RXD[3..0] is invalid when RXDV is de-asserted.
- RMII Rx Mode: The RXD[1:0] bits are synchronous with REFIN. For each clock period in which CRS_DV is asserted, two bits of recovered data are sent from the PHY to the MAC.
- MII Tx Mode: The TXD[3..0] bits are synchronous with TXCLK. When TXEN is asserted, TXD[3..0] presents valid data from the MAC on the MII interface. TXD[3..0] has no effect when TXEN is de-asserted.
- RMII Tx Mode: The TXD[1:0] bits are synchronous with REFIN. For each clock period in which TX_EN is asserted, two bits of data are received by the PHY from the MAC.

Strapping Options

Pin Number	Pin Name	Pin Type ¹	Pin Function
14	AMDIX/RXD3	IO/lpu	1 = AMDIX enable 0 = AMDIX disable
15	P3/RXD2	IO/lpd	The PHY address is set by P[3:0] at power-on reset. P0 and P1 must have external pull-up or pull-down to set address at start up.
11	P2/INT	IO/lpd	
31	P0/LED0	IO	
32	P1/LED1	IO	
16	RXTRI/RXD1	IO/lpd	1 = Receiver Tristate Enable; 0 = Receiver Tristate Disable
17	FDPX/RXD0	IO/lpu	1=Full duplex 0=Half duplex Ignored if Auto negotiation is enabled
18	RMII/RXDV	IO/lpd	1 = RMII mode 0 = MII mode
20	ANSEL/RXCLK	IO/lpu	1=Enable auto negotiation 0=Disable auto negotiation
21	NOD/RXER	IO/lpd	0=Node mode 1=repeater mode
22	SPEED/TXCLK	IO/lpu	1=100M mode 0=10M mode Ignored if Auto negotiation is enabled

1. IO/lpu = Digital Input with internal 20k pull-up during power on reset/hardware reset; output pin otherwise.
2. IO/lpd = Digital Input with internal 20k pull-down during power on reset/hardware reset; output pin otherwise.

Functional Description

The ICS1894-32 is an ethernet PHYceiver. During data transmission, it accepts sequential nibbles/di-bits from the MAC (Media Access Control), converts them into a serial bit stream, encodes them, and transmits them over the medium through an external isolation transformer. When receiving data, the ICS1894-32 converts and decodes a serial bit stream (acquired from an isolation transformer that interfaces with the medium) into sequential nibbles/di-bits. It subsequently presents these nibbles/di-bits to the MAC Interface.

The ICS1894-32 implements the OSI model's physical layer, consisting of the following, as defined by the ISO/IEC 8802-3 standard:

- Physical Coding sublayer (PCS)
- Physical Medium Attachment sublayer (PMA)

- Physical Medium Dependent sublayer (PMD)
- Auto-Negotiation sublayer

The ICS1894-32 is transparent to the next layer of the OSI model, the link layer. The link layer has two sublayers: the Logical Link Control sublayer and the MAC sublayer. The ICS1894-32 can interface directly with the MAC via MII/RMII interface signals.

The ICS1894-32 transmits framed packets acquired from its MAC Interface and receives encapsulated packets from another PHY, which it translates and presents to its MAC Interface.

Note: As per the ISO/IEC standard, the ICS1894-32 does not affect, nor is it affected by, the underlying structure of the MAC frame it is conveying.

100Base-TX Operation

During 100Base-TX data transmission, the ICS1894-32 accepts packets from the MAC and inserts Start-of-Stream Delimiters (SSDs) and End-of-Stream Delimiters (ESDs) into the data stream. The ICS1894-32 encapsulates each MAC frame, including the preamble, with an SSD and an ESD. As per the ISO/IEC Standard, the ICS1894-32 replaces the first octet of each MAC preamble with an SSD and appends an ESD to the end of each MAC frame.

When receiving data from the medium, the ICS1894-32 removes each SSD and replaces it with the pre-defined preamble pattern before presenting the data on the MAC Interface. When the ICS1894-32 encounters an ESD in the received data stream, signifying the end of the frame, it ends the presentation of data on the MAC Interface. Therefore, the local MAC receives an unaltered copy of the transmitted frame sent by the remote MAC.

During periods when MAC frames are being neither transmitted nor received, the ICS1894-32 signals and detects the IDLE condition on the Link Segment. In the 100Base-TX mode, the ICS1894-32 transmit channel sends a continuous stream of scrambled ones to signify the IDLE condition. Similarly, the ICS1894-32 receive channel continually monitors its data stream and looks for a pattern of scrambled ones. The results of this signaling and monitoring provide the ICS1894-32 with the means to establish the integrity of the Link Segment between itself and its remote link partner and inform its Station Management Entity (SME) of the link status.

10Base-T Operation

During 10Base-T data transmission, the ICS1894-32 inserts only the IDL delimiter into the data stream. The ICS1894-32 appends the IDL delimiter to the end of each MAC frame. However, since the 10Base-T preamble already has a Start-of-Frame delimiter (SFD), it is not required that the ICS1894-32 insert an SSD-like delimiter.

When receiving data from the medium (such as a twisted-pair cable), the ICS1894-32 uses the preamble to synchronize its receive clock. When the ICS1894-32 receive clock establishes lock, it presents the preamble nibbles to the MAC Interface.

In 10M operations, during periods when MAC frames are being neither transmitted nor received, the ICS1894-32 signals and detects Normal Link Pulses. This action allows the integrity of the Link Segment with the remote link partner

to be established and then reported to the ICS1894-32's SME.

Auto-Negotiation

The ICS1894-32 conforms to the auto-negotiation protocol, defined in Clause 28 of the IEEE 802.3u specification. Autonegotiation is enabled by either hardware pin strapping (pin 20) or software (register 0h bit 12).

Auto-negotiation allows link partners to select the highest common mode of operation. Link partners advertise their capabilities to each other, and then compare their own capabilities with those they received from their link partners. The highest speed and duplex setting that is common to the two link partners is selected as the mode of operation.

The following list shows the speed and duplex operation mode from highest to lowest.

- Priority 1: 100Base-TX, full-duplex
- Priority 2: 100Base-TX, half-duplex
- Priority 3: 10Base-T, full-duplex
- Priority 4: 10Base-T, half-duplex

If auto-negotiation is not supported or the ICS1894-32 link partner is forced to bypass auto-negotiation, the ICS1894-32 sets its operating mode by observing the signal at its receiver. This is known as parallel detection, and allows the ICS1894-32 to establish link by listening for a fixed signal protocol in the absence of auto-negotiation advertisement protocol.

MII Management (MIIM) Interface

The ICS1894-32 supports the IEEE 802.3 MII Management Interface, also known as the Management Data Input / Output (MDIO) Interface. This interface allows upper-layer devices to monitor and control the state of the ICS1894-32. An external device with MIIM capability is used to read the PHY status and/or configure the PHY settings. Additional details on the MIIM interface can be found in Clause 22.2.4.5 of the IEEE 802.3u Specification.

The MIIM interface consists of the following:

- A physical connection that incorporates the clock line (MDC) and the data line (MDIO).
- A specific protocol that operates across the aforementioned physical connection that allows an external controller to communicate with one or more

ICS1894-32 devices. Each ICS1894-32 device is assigned a PHY address between 1 and 7 by the P[4:0] strapping pins. P3 and P4 address bits are hardcoded to '0' in design.

- An internal addressable set of thirty-one 8-bit MDIO registers. Register [0:6] are required, and their functions are defined by the IEEE 802.3u Specification. The

additional registers are provided for expanded functionality.

The ICS1894-32 supports MIIM in both MII mode and RMII mode.

The following table shows the MII Management frame format for the ICS1894-32.

MII Management Frame Format

	Preamble	Start of Frame	Read/Write OP Code	PHY Address Bits [4:0]	REG Address Bits [4:0]	TA	Data Bits [15:0]	Idle
Read	32 1's	01	10	00AAA	RRRRR	Z0	DDDDDDDD_DDDDDDD	Z
Write	32 1's	01	01	00AAA	RRRRR	10	DDDDDDDD_DDDDDDD	Z

Interrupt (INT)

P2/INT (pin 11) is an optional interrupt signal that is used to inform the external controller that there has been a status update in the ICS1894-32 PHY register. Register 23 shows the status of the various interrupts while register 22 controls the enabling/disabling of the interrupts.

MII Data Interface

The Media Independent Interface (MII) is specified in Clause 22 of the IEEE 802.3u Specification. It provides a common interface between physical layer and MAC layer devices, and has the following key characteristics:

- Supports 10Mbps and 100Mbps data rates.
- Uses a 25MHz reference clock, sourced by the PHY.
- Provides independent 4-bit wide (nibble) transmit and receive data paths.
- Contains two distinct groups of signals: one for transmission and the other for reception.

The ICS1894-32 is configured for MII mode upon power-up or hardware reset with the following:

- A 25MHz crystal connected to REFIN, REFOUT (pins 30, 29), or an external 25MHz clock source (oscillator) connected to REFIN

MII Signal Definition

The following table describes the MII signals. Refer to Clause 22 of the IEEE 802.3u Specification for detailed information.

MII Signal Name	Direction (with respect to PHY, ICS1894-32 signal)	Direction (with respect to MAC)	Description
TXCLK	Output	Input	Transmit Clock (2.5MHz for 10Mbps; 25MHz for 100Mbps)
TXEN	Input	Output	Transmit Enable
TXD[3:0]	Input	Output	Transmit Data [3:0]
RXCLK	Output	Input	Receive Clock (2.5MHz for 10Mbps; 25MHz for 100Mbps)
RXDV	Output	Input	Receive Data Valid
RXD[3:0]	Output	Input	Receive Data [3:0]
RXER	Output	Input, or (not required)	Receive Error

Transmit Clock (TXCLK)

TXCLK is sourced by the PHY. It is a continuous clock that provides the timing reference for TXEN and TXD[3:0]. TXCLK is 2.5MHz for 10Mbps operation and 25MHz for 100Mbps operation.

Transmit Enable (TXEN)

TXEN indicates the MAC is presenting nibbles on TXD[3:0] for transmission. It is asserted synchronously with the first nibble of the preamble and remains asserted while all nibbles to be transmitted are presented on the MII, and is negated prior to the first TXCLK following the final nibble of a frame. TXEN transitions synchronously with respect to TXCLK.

Transmit Data (TXD[3:0])

TXD[3:0] transitions synchronously with respect to TXCLK. When TXEN is asserted, TXD[3:0] are accepted for transmission by the PHY. TXD[3:0] is "00" to indicate idle when TXEN is de-asserted. Values other than "00" on TXD[3:0] while TXEN is de-asserted are ignored by the PHY.

Receive Clock (RXCLK)

RXCLK provides the timing reference for RXDV, RXD[3:0], and RXER.

- In 10Mbps mode, RXCLK is recovered from the line while carrier is active. RXCLK is derived from the PHY's reference clock when the line is idle, or link is down.
- In 100Mbps mode, RXCLK is continuously recovered from the line. If link is down, RXCLK is derived from the PHY's reference clock.

RXCLK is 2.5MHz for 10Mbps operation and 25MHz for 100Mbps operation.

Receive Data Valid (RXDV)

RXDV is driven by the PHY to indicate that the PHY is presenting recovered and decoded nibbles on RXD[3:0].

- In 10Mbps mode, RXDV is asserted with the first nibble of the SFD (Start of Frame Delimiter), and remains asserted until the end of the frame.
- In 100Mbps mode, RXDV is asserted from the first nibble of the preamble to the last nibble of the frame.

RXDV transitions synchronously with respect to RXCLK.

Receive Data (RXD[3:0])

RXD[3:0] transitions synchronously with respect to RXC. For each clock period in which RXDV is asserted, RXD[3:0] transfers a nibble of recovered data from the PHY.

Receive Error (RXER)

RXER is asserted for one or more RXCLK periods to indicate that an error (e.g. a coding error or any error that a

PHY is capable of detecting, and that may otherwise be undetectable by the MAC sub-layer) was detected somewhere in the frame presently being transferred from the PHY. RXER transitions synchronously with respect to RXC. While RXDV is de-asserted, RXER has no effect on the MAC.

Reduced MII (RMII) Data Interface

The Reduced Media Independent Interface (RMII) specifies a low pin count Media Independent Interface (MII). It provides a common interface between physical layer and MAC layer devices, and has the following key characteristics:

- Supports 10Mbps and 100Mbps data rates.
- Uses a single 50MHz reference clock provided by the MAC or the system board.
- Provides independent 2-bit wide (di-bit) transmit and receive data paths.
- Contains two distinct groups of signals: one for transmission and the other for reception.

In RMII mode, a 50 MHz reference clock is connected to REFIN(pin 30).

RMII Signal Definition

The following table describes the RMII signals. Refer to RMII Specification for detailed information.

RMII Signal Name	Direction (with respect to PHY, ICS1894-32 signal)	Direction (with respect to MAC)	Description
REFIN	Input	Input or Output	Synchronous 50 MHz clock reference for receive, transmit and control interface
TX_EN	Input	Output	Transmit Enable
TXD[1:0]	Input	Output	Transmit Data [1:0]
RXD[1:0]	Output	Input	Receive Data [1:0]
RX_ER	Output	Input, or (not required)	Receive Error
CRS_DV[RXDV]	Output	Input	Carrier Sense/Data Valid

Reference Clock (REFIN)

REFIN is sourced by the MAC or system board. It is a continuous 50MHz clock that provides the timing reference for TX_EN, TXD[1:0], CRS_DV, RXD[1:0], and RX_ER.

Transmit Enable (TX_EN)

TX_EN indicates that the MAC is presenting di-bits on TXD[1:0] for transmission. It is asserted synchronously with the first nibble of the preamble and remains asserted while all di-bits to be transmitted are presented on the RMII, and is negated prior to the first REFIN following the final di-bit of a frame. TX_EN transitions synchronously with respect to REFIN.

Transmit Data [1:0] (TXD[1:0])

TXD[1:0] transitions synchronously with respect to REFIN. When TX_EN is asserted, TXD[1:0] are accepted for transmission by the PHY. TXD[1:0] is "00" to indicate idle when TX_EN is de-asserted. Values other than "00" on TXD[1:0] while TX_EN is de-asserted are ignored by the PHY.

Carrier Sense/Data Valid (CRS_DV[RXDV])

CRS_DV, identified as RXDV (pin 18), shall be asserted by the PHY when the receive medium is non-idle. The specifics of the definition of idle for 10BASE-T and 100BASE-X are contained in IEEE 802.3 [1] and IEEE 802.3u [2]. CRS_DV is asserted asynchronously on detection of carrier due to the criteria relevant to the operating mode. That is, in 10BASE-T mode, when squelch is passed or in 100BASE-X mode when 2 non-contiguous zeroes in 10 bits are detected carrier is said to be detected.

Loss of carrier shall result in the deassertion of CRS_DV synchronous to the cycle of REFIN which presents the first di-bit of a nibble onto RXD[1:0] (i.e. CRS_DV is deasserted only on nibble boundaries). If the PHY has additional bits to be presented on RXD[1:0] following the initial deassertion of CRS_DV, then the PHY shall assert CRS_DV on cycles of REFIN which present the second di-bit of each nibble and deassert CRS_DV on cycles of REFIN which present the first di-bit of a nibble. The result is: Starting on nibble boundaries CRS_DV toggles at 25 MHz in 100Mb/s mode and 2.5 MHz in 10Mb/s mode when the Carrier event ends before the RX_DV signal internal to the PHY is deasserted (i.e. the FIFO still has bits to transfer when the carrier event ends.) Therefore, the MAC can accurately recover RX_DV and the Carrier event end time. During a false carrier event, CRS_DV shall remain asserted for the duration of carrier activity.

The data on RXD[1:0] is considered valid once CRS_DV is asserted. However, since the assertion of CRS_DV is asynchronous relative to REFIN, the data on RXD[1:0] shall be "00" until proper receive signal decoding takes place (see definition of RXD[1:0] behavior).

***Note:** CRS_DV is asserted asynchronously in order to minimize latency of control signals through the PHY.

Receive Data [1:0] (RXD[1:0])

RXD[1:0] transitions synchronously to REFIN. For each clock period in which CRS_DV is asserted, RXD[1:0] transfers two bits of recovered data from the PHY. RXD[1:0] is "00" to indicate idle when CRS_DV is de-asserted. Values other than "00" on RXD[1:0] while CRS_DV is de-asserted

are ignored by the MAC.

Receive Error (RX_ER)

RX_ER is asserted for one or more REFIN periods to indicate that an error (e.g. a coding error or any error that a PHY is capable of detecting, and that may otherwise be undetectable by the MAC sub-layer) was detected somewhere in the frame presently being transferred from the PHY. RX_ER transitions synchronously with respect to REFIN. While CRS_DV is de-asserted, RX_ER has no effect on the MAC.

Auto-MDI/MDIX Crossover

The ICS1894-32 includes the auto-MDI/MDIX crossover feature. In a typical CAT 5 Ethernet installation the transmit twisted pair signal pins of the RJ45 connector are crossed over in the CAT 5 wiring to the partners receive twisted pair signal pins and receive twisted pair to the partners transmit twisted pair. This is usually accomplished in the wiring plant. Hubs generally wire the RJ45 connector crossed to accomplish the crossover. Two types of CAT 5 cables (straight and crossed) are available to achieve the correct connection. The Auto-MDI/MDIX feature automatically corrects for miss-wired installations by automatically swapping transmit and receive signal pairs at the PHY when no link results. Auto-MDI/MDIX is automatic, but may be disabled for test purposes by writing MDIO register 19 Bits 9:8 in the MDIO register. The Auto-MDI/MDIX function is independent of Auto-Negotiation and precedes Auto-Negotiation when enabled.

Auto MDI/MDIX Table

AMDIX_EN (pin 14)	AMDIX_EN [Reg 19:9]	MDI_MODE [Reg 19:8]	Tx/Rx MDI Configuration
x	0	0	straight
x	0	1	cross
0	1	x	straight
1	1	x	straight/cross (auto select)
Default			
1	1	0	straight/cross (auto select)

Definitions:

straight transmit = TP_AP & TP_AN
receive = TP_BP & TP_BN

cross transmit = TP_BP & TP_BN
receive = TP_AP & TP_AN

AMDIX_EN (Pin 14) AMDIX enable pin with 20 kOhm pull-up resistor

AMDIX_EN [19:9] MDIO register 19h bit 9

MDI_MODE [19:8] MDIO register 19h bit 8

Power Management

The ICS1894-32 supports a Deep Power Mode (DPD) that is enabled under the following conditions:

1. The Phy is not Receiving any signal from the partner (Link Down)
2. The MAC is not transmitting data to the Phy (TXEN Low)

Once the above conditions are met, the Phy goes into DPD mode after 32s (typical).

The logic internal to the device can be selectively shut down in DPD mode depending on Register 24 Bits 8-4.

Block Diagram of the Different Sections of the PHY as Affected by Register 24 bits

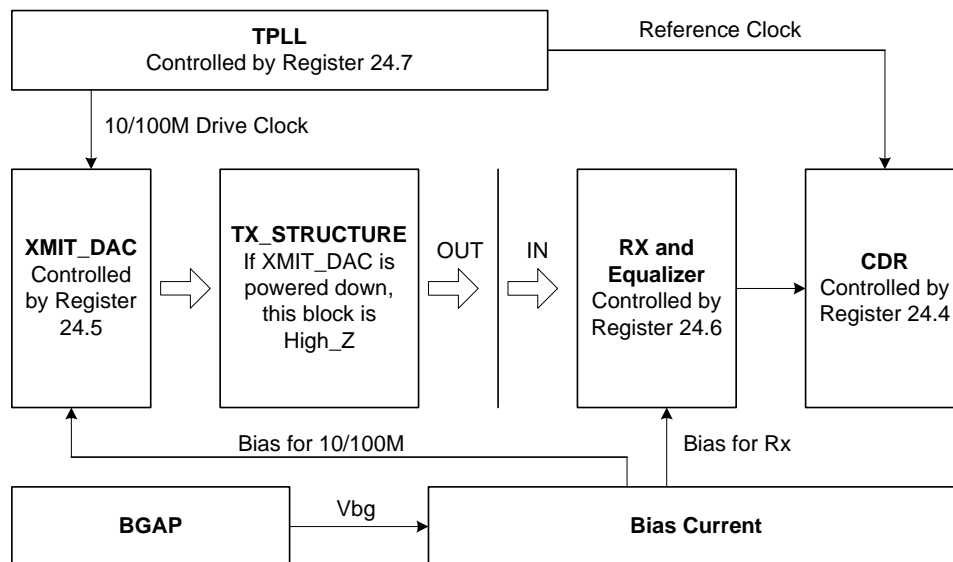

Clock Reference Interface

The REFIN pin provides the ICS1894-32 Clock Reference Interface. The ICS1894-32 requires a single clock reference with a frequency of 25 MHz \pm 50 parts per million. This accuracy is necessary to meet the interface requirements of the ISO/IEEE 8802-3 standard, specifically clauses 22.2.2.1 and 24.2.3.4. The ICS1894-32 supports two clock source configurations: a CMOS oscillator or a CMOS driver. The input to REFIN is CMOS (10% to 90% VDD), not TTL. Alternately, a 25MHz crystal may be used.

Crystal or Oscillator Connection

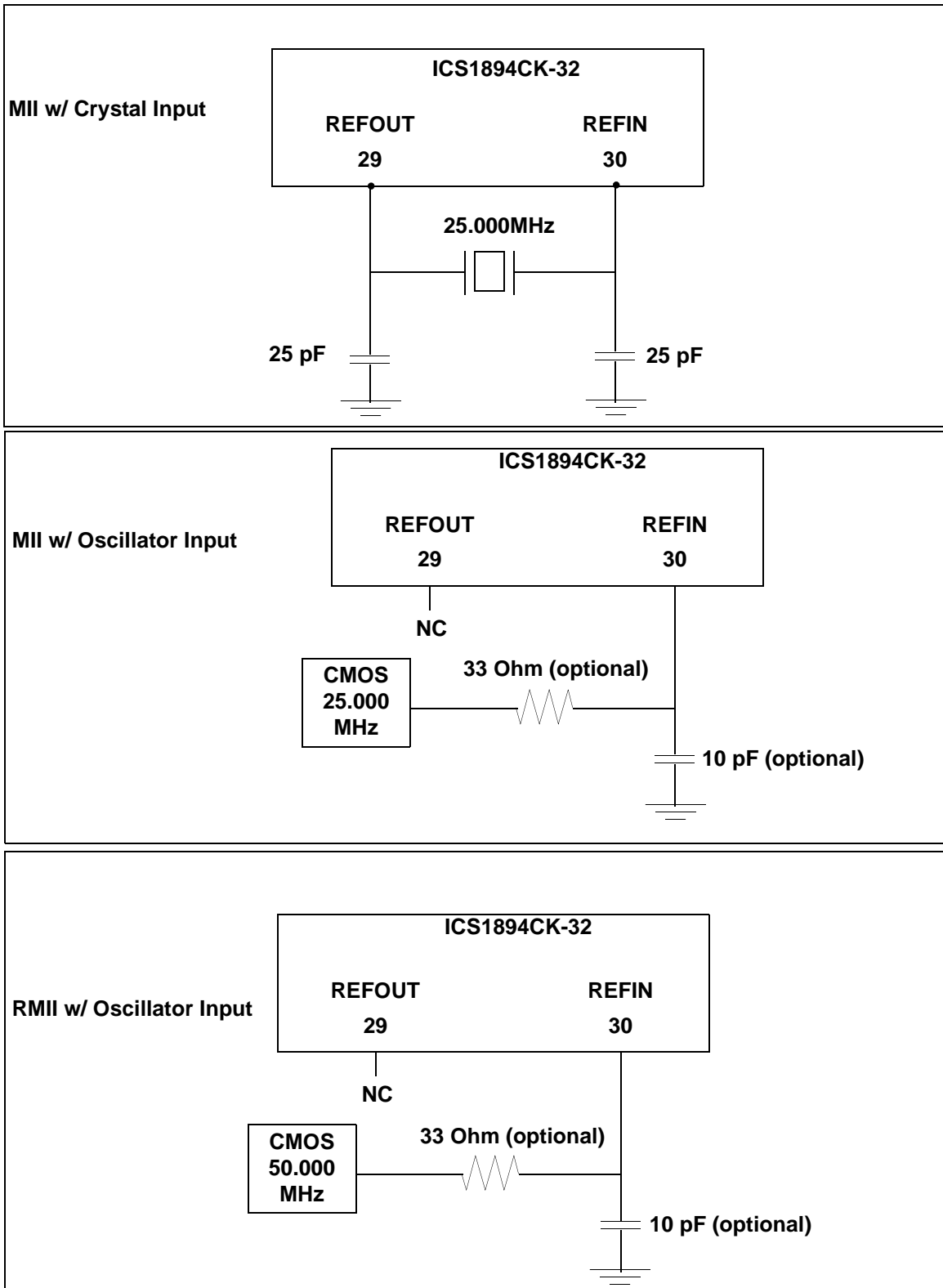

If a crystal is used as the clocking source, connect it to both the REFIN (pin 30) and REFOUT (pin 29) pins of the ICS1894-32. A pair of bypass capacitors on either side of the crystal are connected to ground. The crystal is used in the parallel resonance or anti-resonance mode. The value of the load caps serve to adjust the final frequency of the crystal oscillation. Typical applications would use 25 pF load caps. The exact value will be affected by the board routing capacitance on REFIN and REFOUT pins. Smaller load capacitors raise the frequency of oscillation.

Once the exact value of load capacitance is established it will be the same for all boards using the same specification crystal. The best way to measure the crystal frequency is to measure the frequency of TXCLK (pin 22) using a frequency counter with a 1 second gate time. Using the buffered output TXCLK prevents the crystal frequency from being affected by the measurement. The crystal specification is shown in the *25MHz Crystal Specification* table.

25 MHz Crystal Specification Table

Specifications	Symbol	Minimum	Typical	Maximum	Unit
Fundamental Frequency	F0	24.99875	25.00000	25.00125	MHz
Freq. Tolerance	$\Delta F/f$			± 50	ppm
Input Capacitance	Cin		3		pF

25 MHz Oscillator Specification table

Specifications	Symbol	Minimum	Typical	Maximum	Unit
Output Frequency	F0	24.99875	25.00000	25.00125	MHz
Freq. Stability (including aging)	$\Delta F/f$			± 50	ppm
Duty cycle CMOS level one-half VDD	Tw/T	35		65	%
VIH		2.79			Volts
VIL				0.33	Volts
Period Jitter	Tjitter			500	pS
Input Capacitance	CIN		3		pF

50 MHz Oscillator Specification table

Specifications	Symbol	Minimum	Typical	Maximum	Unit
Output Frequency	F0	49.9975	50.00000	50.0025	MHz
Freq. Stability (including aging)	$\Delta F/f$			± 50	ppm
Duty cycle CMOS level one-half VDD	Tw/T	35		65	%
VIH		2.79			Volts
VIL				0.33	Volts
Period Jitter	Tjitter			500	pS
Input Capacitance	CIN		3		pF

Status Interface

The ICS1894-32 has two multi-function configuration pins that report the PHY status by providing signals that are

intended for driving LEDs. Configuration is set by Bank0 Register 20.

Pins for Monitoring the Data Link table

Pin	Status Events that drive the LEDs
P0/LED0	Link, Activity, Tx, Rx, COL, Mode, Dplx
P1/LED1	Link, Activity, Tx, Rx, COL, Mode, Dplx

Note:

1. During either power-on reset or hardware reset, each multi-function configuration pin is an input that is sampled when the ICS1894-32 exits the reset state. After sampling is complete, these pins are output pins that can drive status LEDs.
2. A software reset does not affect the state of a multi-function configuration pin. During a software reset, all multi-function configuration pins are outputs.
3. Each multi-function configuration pin must be pulled either up or down with a resistor to establish the address of the ICS1894-32. LEDs may be placed in series with these

resistors to provide a designated status indicator as described in the *Pins for Monitoring the Data Link* table. Use 1K Ω resistors.

Caution: Pins listed in the *Pins for Monitoring the Data Link* table must not float.

4. As outputs, the asserted state of a multi-function configuration pin is the inverse of the sense sampled during reset. This inversion provides a signal that can illuminate an LED during an asserted state. For example, if a multi-function configuration pin is pulled down to ground through an LED and a current-limiting resistor, then the sampled sense of the input is low. To illuminate this LED for the asserted state, the output is driven high.

5. Adding 10K Ω resistors across the LEDs ensures the PHY address is fully defined during slow VDD power-ramp conditions.

6. PHY address 00 tri-states the MII interface. (Do not select PHY address 00 unless you want the MII tri-stated.)

The following figure shows typical biasing and LED connections for the ICS1894-32.

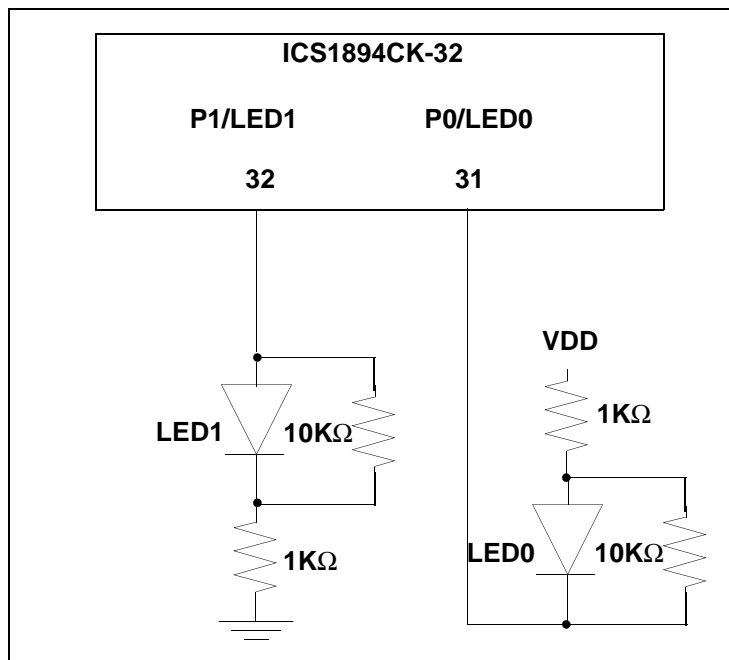

The above circuit decodes the PHY address = 1

Register Map

Register Address	Register Name	Basic / Extended
0	Control	Basic
1	Status	Basic
2,3	PHY Identifier	Extended
4	Auto-Negotiation Advertisement	Extended
5	Auto-Negotiation Link Partner Ability	Extended
6	Auto-Negotiation Expansion	Extended
7	Auto-Negotiation Next Page Transmit	Extended
8	Auto-Negotiation Next Page Link Partner Ability	Extended
9 through 15	Reserved by IEEE	Extended
16 through 31	Vendor-Specific (IDT) Registers	Extended

Register Description

Bit	Definition	When Bit = 0	When Bit = 1	Access ²	SF ²	Default ³	Hex
Register 0h - Control							
0.15	Reset	No effect	Reset mode	RW	SC	0	3
0.14	Loopback enable	Disable Loopback mode	Enable Loopback mode	RW	–	0	
0.13	Speed select ¹	10 Mbps operation	100 Mbps operation	RW	–	1	
0.12	Auto-Negotiation enable	Disable Auto-Negotiation	Enable Auto-Negotiation	RW	–	1	
0.11	Low-power mode	Normal power mode	Low-power mode	RW	–	0	0/4†
0.10	Isolate	No effect	Isolate from MII	RW	–	0/1†	
0.9	Auto-Negotiation restart	No effect	Restart Auto-Negotiation	RW	SC	0	
0.8	Duplex mode ¹	Half-duplex operation	Full-duplex operation	RW	–	0	0
0.7	Collision test	No effect	Enable collision test	RW	–	0	
0.6	IEEE reserved	Always 0	N/A	RO	–	0‡	
0.5	IEEE reserved	Always 0	N/A	RO	–	0‡	
0.4	IEEE reserved	Always 0	N/A	RO	–	0‡	
0.3	IEEE reserved	Always 0	N/A	RO	–	0‡	0
0.2	IEEE reserved	Always 0	N/A	RO	–	0‡	
0.1	IEEE reserved	Always 0	N/A	RO	–	0‡	
0.0	IEEE reserved	Always 0	N/A	RO	–	0‡	

Bit	Definition	When Bit = 0	When Bit = 1	Access ²	SF ²	Default ³	Hex
Register 1h - Control							
1.15	100Base-T4	Always 0. (Not supported.)	N/A	RO	–	0	7
1.14	100Base-TX full duplex	Mode not supported	Mode supported	CW	–	1	
1.13	100Base-TX half duplex	Mode not supported	Mode supported	CW	–	1	
1.12	10Base-T full duplex	Mode not supported	Mode supported	CW	–	1	
1.11	10Base-T half duplex	Mode not supported	Mode supported	CW	–	1	8
1.10	IEEE reserved	Always 0	N/A	CW	–	0†	
1.9	IEEE reserved	Always 0	N/A	CW	–	0†	
1.8	IEEE reserved	Always 0	N/A	CW	–	0†	
1.7	IEEE reserved	Always 0	N/A	CW	–	0†	0
1.6	MF Preamble suppression	PHY requires MF Preambles	PHY does not require MF Preambles	RO	–	0	
1.5	Auto-Negotiation complete	Auto-Negotiation is in process, if enabled	Auto-Negotiation is completed	RO	LH	0	
1.4	Remote fault	No remote fault detected	Remote fault detected	RO	LH	0	
1.3	Auto-Negotiation ability	N/A	Always 1: PHY has Auto-Negotiation ability	RO	–	1	9
1.2	Link status	Link is invalid/down	Link is valid/established	RO	LL	0	
1.1	Jabber detect	No jabber condition	Jabber condition detected	RO	LH	0	
1.0	Extended capability	N/A	Always 1: PHY has extended capabilities	RO	–	1	
Register 2h - PHY Identifier							
2.15	OUI bit 3 c	N/A	N/A	CW	–	0	0
2.14	OUI bit 4 d	N/A	N/A	CW	–	0	
2.13	OUI bit 5 e	N/A	N/A	CW	–	0	
2.12	OUI bit 6 f	N/A	N/A	CW	–	0	
2.11	OUI bit 7 g	N/A	N/A	CW	–	0	0
2.10	OUI bit 8 h	N/A	N/A	CW	–	0	
2.9	OUI bit 9 i	N/A	N/A	CW	–	0	
2.8	OUI bit 10 j	N/A	N/A	CW	–	0	
2.7	OUI bit 11 k	N/A	N/A	CW	–	0	1
2.6	OUI bit 12 l	N/A	N/A	CW	–	0	
2.5	OUI bit 13 m	N/A	N/A	CW	–	0	
2.4	OUI bit 14 n	N/A	N/A	CW	–	1	

Bit	Definition	When Bit = 0	When Bit = 1	Access ²	SF ²	Default ³	Hex
2.3	OUI bit 15 o	N/A	N/A	CW	–	0	5
2.2	OUI bit 16 p	N/A	N/A	CW	–	1	
2.1	OUI bit 17 q	N/A	N/A	CW	–	0	
2.0	OUI bit 18 r	N/A	N/A	CW	–	1	
Register 3h - PHY Identifier							
3.15	OUI bit 19 s	N/A	N/A	CW	–	1	F
3.14	OUI bit 20 t	N/A	N/A	CW	–	1	
3.13	OUI bit 21 u	N/A	N/A	CW	–	1	
3.12	OUI bit 22 v	N/A	N/A	CW	–	1	
3.11	OUI bit 23 w	N/A	N/A	CW	–	0	4
3.10	OUI bit 24 x	N/A	N/A	CW	–	1	
3.9	Manufacturer's Model Number bit 5	N/A	N/A	CW	–	0	5
3.8	Manufacturer's Model Number bit 4	N/A	N/A	CW	–	0	
3.7	Manufacturer's Model Number bit 3	N/A	N/A	CW	–	0	
3.6	Manufacturer's Model Number bit 2	N/A	N/A	CW	–	1	
3.5	Manufacturer's Model Number bit 1	N/A	N/A	CW	–	0	
3.4	Manufacturer's Model Number bit 0	N/A	N/A	CW	–	1	0
3.3	Revision Number bit 3	N/A	N/A	CW	–	0	
3.2	Revision Number bit 2	N/A	N/A	CW	–	0	
3.1	Revision Number bit 1	N/A	N/A	CW	–	0	
3.0	Revision Number bit 0	N/A	N/A	CW	–	0	
Register 4h - Auto-Negotiation Advertisement							
4.15	Next Page	Next page not supported	Next page supported	R/W	–	0	0
4.14	IEEE reserved	Always 0	N/A	CW	–	0†	
4.13	Remote fault	Locally, no faults detected	Local fault detected	R/W	–	0	
4.12	IEEE reserved	Always 0	N/A	CW	–	0†	
4.11	IEEE reserved	Always 0	N/A	CW	–	0†	1
4.10	IEEE reserved	Always 0	N/A	CW	–	0†	
4.9	100Base-T4	Always 0. (Not supported.)	N/A	CW	–	0	
4.8	100Base-TX, full duplex	Do not advertise ability	Advertise ability	R/W	–	1	

Bit	Definition	When Bit = 0	When Bit = 1	Access ²	SF ²	Default ³	Hex
4.7	100Base-TX, half duplex	Do not advertise ability	Advertise ability	R/W	–	1	E
4.6	10Base-T, full duplex	Do not advertise ability	Advertise ability	R/W	–	1	
4.5	10Base-T half duplex	Do not advertise ability	Advertise ability	R/W	–	1	
4.4	Selector Field bit S4	IEEE 802.3-specified default	N/A	CW	–	0	1
4.3	Selector Field bit S3	IEEE 802.3-specified default	N/A	CW	–	0	
4.2	Selector Field bit S2	IEEE 802.3-specified default	N/A	CW	–	0	
4.1	Selector Field bit S1	IEEE 802.3-specified default	N/A	CW	–	0	
4.0	Selector Field bit S0	N/A	IEEE 802.3-specified default	CW	–	1	
Register 5h - Auto-Negotiation Link Partner Ability							
5.15	Next Page	Next Page disabled	Next Page enabled	RO	–	0	0
5.14	Acknowledge	Always 0	N/A	RO	–	0	
5.13	Remote fault	No faults detected	Remote fault detected	RO	–	0	
5.12	IEEE reserved	Always 0	N/A	RO	–	0†	
5.11	IEEE reserved	Always 0	N/A	RO	–	0†	0
5.10	IEEE reserved	Always 0	N/A	RO	–	0†	
5.9	100Base-T4	Always 0. (Not supported.)	N/A	RO	–	0	
5.8	100Base-TX, full duplex	Link partner is not capable	Link partner is capable	RO	–	0	0
5.7	100Base-TX, half duplex	Link partner is not capable	Link partner is capable	RO	–	0	
5.6	10Base-T, full duplex	Link partner is not capable	Link partner is capable	RO	–	0	
5.5	10Base-T, half duplex	Link partner is not capable	Link partner is capable	RO	–	0	
5.4	Selector Field bit S4	IEEE 802.3 defined. Always 0.	N/A	RO	–	0	
5.3	Selector Field bit S3	IEEE 802.3 defined. Always 0.	N/A	CW	–	0	0
5.2	Selector Field bit S2	IEEE 802.3 defined. Always 0.	N/A	CW	–	0	
5.1	Selector Field bit S1	IEEE 802.3 defined. Always 0.	N/A	CW	–	0	
5.0	Selector Field bit S0	N/A	IEEE 802.3 defined. Always 1.	CW	–	0	

Bit	Definition	When Bit = 0	When Bit = 1	Access ²	SF ²	Default ³	Hex
Register 6h - Auto-Negotiation Expansion							
6.15	IEEE reserved	Always 0	N/A	CW	–	0†	0
6.14	IEEE reserved	Always 0	N/A	CW	–	0†	
6.13	IEEE reserved	Always 0	N/A	CW	–	0†	
6.12	IEEE reserved	Always 0	N/A	CW	–	0†	
6.11	IEEE reserved	Always 0	N/A	CW	–	0†	0
6.10	IEEE reserved	Always 0	N/A	CW	–	0†	
6.9	IEEE reserved	Always 0	N/A	CW	–	0†	
6.8	IEEE reserved	Always 0	N/A	CW	–	0†	
6.7	IEEE reserved	Always 0	N/A	CW	–	0†	0
6.6	IEEE reserved	Always 0	N/A	CW	–	0†	
6.5	IEEE reserved	Always 0	N/A	CW	–	0†	
6.4	Parallel detection fault	No Fault	Multiple technologies detected	RO	LH	0	
6.3	Link partner Next Page able	Link partner is not Next Page able	Link partner is Next Page able	RO	–	0	4
6.2	Next Page able	Local device is not Next Page able	Local device is Next Page able	RO	–	1	
6.1	Page received	Next Page not received	Next Page received	RO	LH	0	
6.0	Link partner Auto-Negotiation able	Link partner is not Auto-Negotiation able	Link partner is Auto-Negotiation able	RO	–	0	
Register 7h - Auto-Negotiation Next Page Transmit							
7.15	Next Page	Last Page	Additional Pages follow	RW	–	0	2
7.14	IEEE reserved	Always 0	N/A	RO	–	0†	
7.13	Message Page	Unformatted Page	Message Page	RW	–	1	
7.12	Acknowledge 2	Cannot comply with Message	Can comply with Message	RW	–	0	
7.11	Toggle	Previous Link Code Word was zero	Previous Link Code Word was one	RO	–	0	0
7.10	Message code field /Unformatted code field	Bit value depends on the particular message	Bit value depends on the particular message	RW	–	0	
7.9	Message code field /Unformatted code field	Bit value depends on the particular message	Bit value depends on the particular message	RW	–	0	
7.8	Message code field /Unformatted code field	Bit value depends on the particular message	Bit value depends on the particular message	RW	–	0	

Bit	Definition	When Bit = 0	When Bit = 1	Access ²	SF ²	Default ³	Hex
7.7	Message code field /Unformatted code field	Bit value depends on the particular message	Bit value depends on the particular message	RW	–	0	0
7.6	Message code field /Unformatted code field	Bit value depends on the particular message	Bit value depends on the particular message	RW	–	0	
7.5	Message code field /Unformatted code field	Bit value depends on the particular message	Bit value depends on the particular message	RW	–	0	
7.4	Message code field /Unformatted code field	Bit value depends on the particular message	Bit value depends on the particular message	RW	–	0	
7.3	Message code field /Unformatted code field	Bit value depends on the particular message	Bit value depends on the particular message	RW	–	0	1
7.2	Message code field /Unformatted code field	Bit value depends on the particular message	Bit value depends on the particular message	RW	–	0	
7.1	Message code field /Unformatted code field	Bit value depends on the particular message	Bit value depends on the particular message	RW	–	0	
7.0	Message code field /Unformatted code field	Bit value depends on the particular message	Bit value depends on the particular message	RW	–	1	
Register 8h - Auto-Negotiation Next Page Link Partner Ability							
8.15	Next Page	Last Page	Additional Pages follow	RO	–	0	0
8.14	IEEE reserved	Always 0	N/A	RO	–	0†	
8.13	Message Page	Unformatted Page	Message Page	RO	–	0	
8.12	Acknowledge 2	Cannot comply with Message	Can comply with Message	RO	–	0	
8.11	Toggle	Previous Link Code Word was zero	Previous Link Code Word was one	RO	–	0	0
8.10	Message code field /Unformatted code field	Bit value depends on the particular message	Bit value depends on the particular message	RO	–	0	
8.9	Message code field /Unformatted code field	Bit value depends on the particular message	Bit value depends on the particular message	RO	–	0	
8.8	Message code field /Unformatted code field	Bit value depends on the particular message	Bit value depends on the particular message	RO	–	0	
8.7	Message code field /Unformatted code field	Bit value depends on the particular message	Bit value depends on the particular message	RO	–	0	0
8.6	Message code field /Unformatted code field	Bit value depends on the particular message	Bit value depends on the particular message	RO	–	0	
8.5	Message code field /Unformatted code field	Bit value depends on the particular message	Bit value depends on the particular message	RO	–	0	
8.4	Message code field /Unformatted code field	Bit value depends on the particular message	Bit value depends on the particular message	RO	–	0	

Bit	Definition	When Bit = 0	When Bit = 1	Access ²	SF ²	Default ³	Hex
8.3	Message code field /Unformatted code field	Bit value depends on the particular message	Bit value depends on the particular message	RO	–	0	0
8.2	Message code field /Unformatted code field	Bit value depends on the particular message	Bit value depends on the particular message	RO	–	0	
8.1	Message code field /Unformatted code field	Bit value depends on the particular message	Bit value depends on the particular message	RO	–	0	
8.0	Message code field /Unformatted code field	Bit value depends on the particular message	Bit value depends on the particular message	RO	–	0	
Register 9 through 15h - Reserved by IEEE							
Register 16h - Extended Control Register							
16.15	Command Override Write enable	Disabled	Enabled	RW	SC	0	–
16.14	ICS reserved	Read unspecified	Read unspecified	RW/0	–	0	–
16.13	ICS reserved	Read unspecified	Read unspecified	RW/0	–	0	
16.12	ICS reserved	Read unspecified	Read unspecified	RW/0	–	0	
16.11	ICS reserved	Read unspecified	Read unspecified	RW/0	–	0	
16.10	PHY Address Bit 4			RO	–	0	–
16.9	PHY Address Bit 3			RO	–	0	
16.8	PHY Address Bit 2			RO	–	L	
16.7	PHY Address Bit 1			RO	–	L	
16.6	PHY Address Bit 0			RO	–	L	–
16.5	Stream Cipher Test Mode	Normal operation	Test mode	RW	–	0	
16.4	ICS reserved	Read unspecified	Read unspecified	RW/0	–	–	
16.3	NRZ/NRZI encoding	NRZ encoding	NRZI encoding	RW	–	1	
16.2	Transmit invalid codes	Disabled	Enabled	RW	–	0	8
16.1	ICS reserved	Read unspecified	Read unspecified	RW/0	–	0	
16.0	Stream Cipher disable	Stream Cipher enabled	Stream Cipher disabled	RW	–	0	
Register 17h - Quick Poll Detailed Status Register							
17.15	Data rate	10 Mbps	100 Mbps	RO	–	–	–
17.14	Duplex	Half duplex	Full duplex	RO	–	–	
17.13	Auto-Negotiation Progress Monitor Bit 2	Reference Decode Table	Reference Decode Table	RO	LM X	0	
17.12	Auto-Negotiation Progress Monitor Bit 1	Reference Decode Table	Reference Decode Table	RO	LM X	0	

Bit	Definition	When Bit = 0	When Bit = 1	Access ²	SF ²	Default ³	Hex
17.11	Auto-Negotiation Progress Monitor Bit 0	Reference Decode Table	Reference Decode Table	RO	LM X	0	0
17.10	100Base-TX signal lost	Valid signal	Signal lost	RO	LH	0	
17.9	100BasePLL Lock Error	PLL locked	PLL failed to lock	RO	LH	0	
17.8	False Carrier detect	Normal Carrier or Idle	False Carrier	RO	LH	0	
17.7	Invalid symbol detected	Valid symbols observed	Invalid symbol received	RO	LH	0	0
17.6	Halt Symbol detected	No Halt Symbol received	Halt Symbol received	RO	LH	0	
17.5	Premature End detected	Normal data stream	Stream contained two IDLE symbols	RO	LH	0	
17.4	Auto-Negotiation complete	Auto-Negotiation in process	Auto-Negotiation complete	RO	–	0	
17.3	100Base-TX signal detect	Signal present	No signal present	RO	–	0	0
17.2	Jabber detect	No jabber detected	Jabber detected	RO	LH	0	
17.1	Remote fault	No remote fault detected	Remote fault detected	RO	LH	0	
17.0	Link Status	Link is not valid	Link is valid	RO	LL	0	
Register 18h - 10Base-T Operations Register							
18.15	Remote Jabber Detect	No Remote Jabber Condition detected	Remote Jabber Condition Detected	RO	LH	0	–
18.14	Polarity reversed	Normal polarity	Polarity reversed	RO	LH	0	
18.13	Data Bus Mode	Bit18.13 is latched pin RXTRI		R0	–	–	
18.12		Bit18.12 is latched SI [1x]=RMII mode [01]=SI mode (Serial interface mode) [00]=MII mode		R0	–	L	
18.11	AMDIXEN	AMDIX disable	AMDIX enable	RW	–	L	–
18.10	RXTRI	RX output enable	RX tri-state for MII/RMII interface	RW	–	L	
18.9	REGEN	Vender reserved register access enable	Vender reserved register (byte25~byte31) access disable	RW	–	L	
18.8	TM_SWITCH	Switch TMUX2 to TMUX1, test control		RW	–	0	
18.7	ICS reserved	Read unspecified	Read unspecified	RW/0	–	–	–
18.6	ICS reserved	Read unspecified	Read unspecified	RW/0	–	–	
18.5	Jabber inhibit	Normal Jabber behavior	Jabber Check disabled	RW	–	0	
18.4	ICS reserved	Read unspecified	Read unspecified	RW/1	–	1	

Bit	Definition	When Bit = 0	When Bit = 1	Access ²	SF ²	Default ³	Hex
18.3	Auto polarity inhibit	Polarity automatically corrected	Polarity not automatically corrected	RW	–	0	0
18.2	SQE test inhibit	Normal SQE test behavior	SQE test disabled	RW	–	0	
18.1	Link Loss inhibit	Normal Link Loss behavior	Link Always = Link Pass	RW	–	0	
18.0	Squelch inhibit	Normal squelch behavior	No squelch	RW	–	0	
Register 19h - Extended Control Register							
19.15	Node Mode	Node mode	Repeater mode	RW	–	L	–
19.14	Hardware/Software Mode Speed Select	Use bit00.13 to select speed	Use real time input pin 22 only to select speed	RW	–	L	
19.13	Remote Fault	No faults detected	Remote fault detected	RO	–	0	
19.12	Register Bank select	[01]=Bank1, access register0x00~0x13 and ICS1893CF registers 0x14~0x1F [00]=Bank0, access register0x00~0x13, new defined registers 0x14~0x25 [1x]=Bank0, same as [00]		RW	–	0	
19.11				RW	–	0	2
19.10	ICS reserved	Read unspecified	Read unspecified	RO	–	0	
19.9	AMDIX_EN	See Table on page 11	See Table on page 11	RW	–	1	
19.8	MDI_MODE	See Table on page 11	See Table on page 11	RW	–	0	
19.7	Twisted Pair Tri-State Enable, TPTRI	Twisted Pair Signals are not Tri-States or No effect	Twisted Pair Signals are Tri-States	RW	–	0	0
19.6	ICS reserved	Read unspecified	Read unspecified	RW	–	0	
19.5	ICS reserved	Read unspecified	Read unspecified	RW	–	0	
19.4	ICS reserved	Read unspecified	Read unspecified	RW	–	0	
19.3	ICS reserved	Read unspecified	Read unspecified	RW	–	0	1
19.2	ICS reserved	Read unspecified	Read unspecified	RW	–	0	
19.1	ICS reserved	Read unspecified	Read unspecified	RW	–	0	
19.0	Automatic 100Base-TX Power Down	Do not automatically power down	Power down automatically	RW	–	1	
Register 20h - Extended Control Register							
20.15	Str_enhance	Normal digital output strength	Enhance digital output strength in 1.8V condition	RW		0	3
20.14	ICS reserved	Read unspecified	Read unspecified	RW	–	0	
20.13	ICS reserved	Read unspecified	Read unspecified	RW	–	1	
20.12						1	

Bit	Definition	When Bit = 0	When Bit = 1	Access ²	SF ²	Default ³	Hex
20.11	ICS reserved	Read unspecified	Read unspecified	RW	-	1	F
20.10						1	
20.9						1	
20.8	LED2 Mode	000 = Link Integrity 001 = activity/no activity 010 = Transmit Data 011 = Receive Data 100 = Collision 101 = 10/100 mode 110 = Full Duplex 111 = OFF (Default LED2)	RW			1	E
20.7						1	
20.6						1	
20.5	LED1 Mode	000 = Link Integrity 001 = activity/no activity 010 = Transmit Data 011 = Receive Data 100 = Collision 101 = 10/100 mode (Default LED1) 110 = Full Duplex 111 = OFF	RW			1	9
20.4						0	
20.3						1	
20.2	LED0 Mode	000 = Link Integrity 001 = activity/no activity (Default LED0) 010 = Transmit Data 011 = Receive Data 100 = Collision 101 = 10/100 mode 110 = Full Duplex 111 = LINK_STAT	RW			0	
20.1						0	
20.0						1	
Register 21h - Extended Control Register							
21.15:0	RXER_CNT	Receive error count for RMII mode		RW			0
Register 22h - Extended Control Register							
22.15	Interrupt output enable	Disable interrupt output	Enable interrupt output	RW		0	0
22.14	Interrupt flag read clear enable	Interrupt flag clear by read disable	Interrupt flag clear by read enable	RW		0	
22.13	Interrupt polarity	Output low when interrupt occur	Output high when interrupt occur	RW		0	
22.12	Interrupt flag auto clear enable	Interrupt flag unchanged when interrupt condition removed	Interrupt flag cleared when interrupt condition removed	RW		0	

Bit	Definition	When Bit = 0	When Bit = 1	Access ²	SF ²	Default ³	Hex
22.11	Interrupt flag re-setup enable	Interrupt flag always cleared when write 1 to flag bit	Interrupt flag remains unchanged when interrupt condition exists when a 1 is written to flag bit.	RW		0	0
22.10	Interrupt Enable	Disable Deep power down wake up Interrupt	Enable Deep power down wake up Interrupt	RW		0	
22.9	Interrupt Enable	Disable Deep power down Interrupt	Enable Deep power down Interrupt	RW		0	
22.8	Interrupt Enable	Disable Auto-Negotiation Complete Interrupt	Enable Auto-Negotiation Complete Interrupt	RW		0	
22.7	Interrupt Enable	Disable Jabber Interrupt	Enable Jabber Interrupt	RW		0	0
22.6	Interrupt Enable	Disable Receive Error Interrupt	Enable Receive Error Interrupt	RW		0	
22.5	Interrupt Enable	Disable Page Received Interrupt	Enable Page Received Interrupt	RW		0	
22.4	Interrupt Enable	Disable Parallel Detect Fault Interrupt	Enable Parallel Detect Fault Interrupt	RW		0	
22.3	Interrupt Enable	Disable Link Partner Acknowledge Interrupt	Enable Link Partner Acknowledge Interrupt	RW		0	0
22.2	Interrupt Enable	Disable Link Down Interrupt	Enable Link Down Interrupt	RW		0	
22.1	Interrupt	Disable Remote Fault Interrupt	Enable Remote Fault Interrupt	RW		0	
22.0	Enable	Disable Link Up Interrupt	Enable Link Up Interrupt	RW		0	
Register 23h - Extended Control Register							
23.15:11	Reserved	Reserved		RO		0	0
23.10	Deep power down wake up Interrupt	Deep power down wake up did not occur	Deep power down wake up occurred	RO/SC		0	0
23.9	Deep power down Interrupt	Deep power down did not occur	Deep power down occurred	RO/SC		0	
23.8	Auto-Negotiation Interrupt	Auto-Negotiation Complete did not occur	Auto-Negotiation Complete occurred	RO/SC		0	
23.7	Jabber Interrupt	Jabber did not occur	Jabber occurred	RO/SC		0	0
23.6	Receive Error Interrupt	Receive Error did not occur	Receive Error occurred	RO/SC		0	
23.5	Page Receive Interrupt	Page Receive did not occur	Page Receive occurred	RO/SC		0	
23.4	Parallel Detect Fault Interrupt	Parallel Detect Fault did not occur	Parallel Detect Fault occurred	RO/SC		0	

Bit	Definition	When Bit = 0	When Bit = 1	Access ²	SF ²	Default ³	Hex
23.3	Link Partner Acknowledge Interrupt	Link Partner Acknowledge did not occur	Link Partner Acknowledge occurred	RO/SC		0	0
23.2	Link Down Interrupt	Link Down did not occur	Link Down occurred	RO/SC		0	
23.1	Remote Fault Interrupt	Remote Fault did not occur	Remote Fault occurred	RO/SC		0	
23.0	Link Up Interrupt	Link Up did not occur	Link Up occurred	RO/SC		0	
Register 24h - Extended Control Register							
24.15:12	FIFO Half	RMII FIFO half full bits ((n+3)*2 bit), RMII		RW		2	2
24.11:9	Reserved	Reserved		RW		0	0
24.8	Deep Power down enable	Deep power down(DPD) disable	Deep power down(DPD) enable	RW		0	
24.7	Tpll10_100 DPD Enable	Don't power down 10/100 PLL in DPD mode	Controlled auto power down 10/100 PLL in DPD mode	RW		0	0
24.6	RX 100 DPD Enable	Don't power down RX block in DPD mode	Controlled auto power down of RX block in DPD mode	RW		0	
24.5	Admix_TX DPD Enable	Don't power down admix_dac block in DPD mode	Control auto power down of admix_dac block in DPD mode	RW		0	
24.4	Cdr100_cdr DPD Enable	don't power down in DPD mod	Control auto power down of CDR block in DPD mode	RW		0	
24.3:0	Reserved	Reserved				0	0

Bit	Definition	When Bit = 0	When Bit = 1	Access ²	SF ²	Default ³	Hex
Register 25h - Extended Control Register							
25.15:12	Reserved	Reserved		RW		0	0
25.11	Reserved	Reserved		RW		0	6
25.10	Reserved	Reserved		RW		1	
25.9	TX10BIAS_SET	The normal output current of the Bias block for 10BaseT is 540uA. Changing the register can modify the current with a step size of 5% 000: output 80% current 001: output 85% current 010: output 90% current 011: output 95% current 100: output 100% current 101: output 105% current 110: output 110% current 111: output 115% current		RW		1	4
25.8						0	
25.7						0	
25.6	TX100BIAS_SET	The normal output current of the Bias block for 100BaseTX is 180uA. Changing the register can modify the current with a step size of 5% 000: output 80% current 001: output 85% current 010: output 90% current 011: output 95% current 100: output 100% current 101: output 105% current 110: output 110% current 111: output 115% current		RW		1	
25.5						0	
25.4						0	
25.3	OUTDLY_CTL	This register controls the delay time of the digital control signal for xmit_dac. 00: Longest delay time (same as original design) 01: Long delay time 10: Short delay time 11: Shortest delay time		RW		0	1
25.2							
25.1	Reserved	Reserved		RW		0	
25.0						1	
Register 26 - 31h - Extended Control Register (Reserved)							

Note 1: Ignored if Auto negotiation is enabled.

Note 2: CW = Command Override Write

LH = Latching High

LL = Latching Low

LMX = Latching Maximum

RO = Read Only

RW = Read/Write

RW/0 = Read/Write Zero

RW/1 = Read/Write One

SC = Self-clearing

SF = Special Functions

Note 3: L = Latched on power-up/hardware reset

† = the default state of the pin at reset

DC and AC Operating Conditions

Absolute Maximum Ratings

Stresses above the ratings listed below can cause permanent damage to the ICS1894-32. These ratings, which are standard values for IDT commercially rated parts, are stress ratings only. Functional operation of the device at these or any other conditions above those indicated in the operational sections of the specifications is not implied. Exposure to absolute maximum rating conditions for extended periods can affect product reliability. Electrical parameters are guaranteed only over the recommended operating temperature range.

Parameter	Rating
VDD (measured to VSS)	-0.3 V to 3.6V
Digital Inputs / Outputs	-0.3 V to VDD +0.3 V
Storage Temperature	-55° C to +150° C
Junction Temperature	125° C
Soldering Temperature	260° C
Power Dissipation	See section "DC Operating Conditions for Supply Current"

Recommended Operating Conditions

Parameter	Symbol	Min.	Max.	Units
Ambient Operating Temperature - Commercial	T_A	0	+70	°C
Ambient Operating Temperature - Industrial	T_A	-40	+85	°C
Power Supply Voltage (measured to VSS)	VDD	+3.14	+3.47	V

Recommended Component Values

Parameter	Minimum	Typical	Maximum	Tolerance	Units
TCSR Resistor Value	–	1.82k to GND 18.2k to VDD	–	1%	Ω
LED Resistor Value		1k		–	Ω

ICS1894-32 TCSR

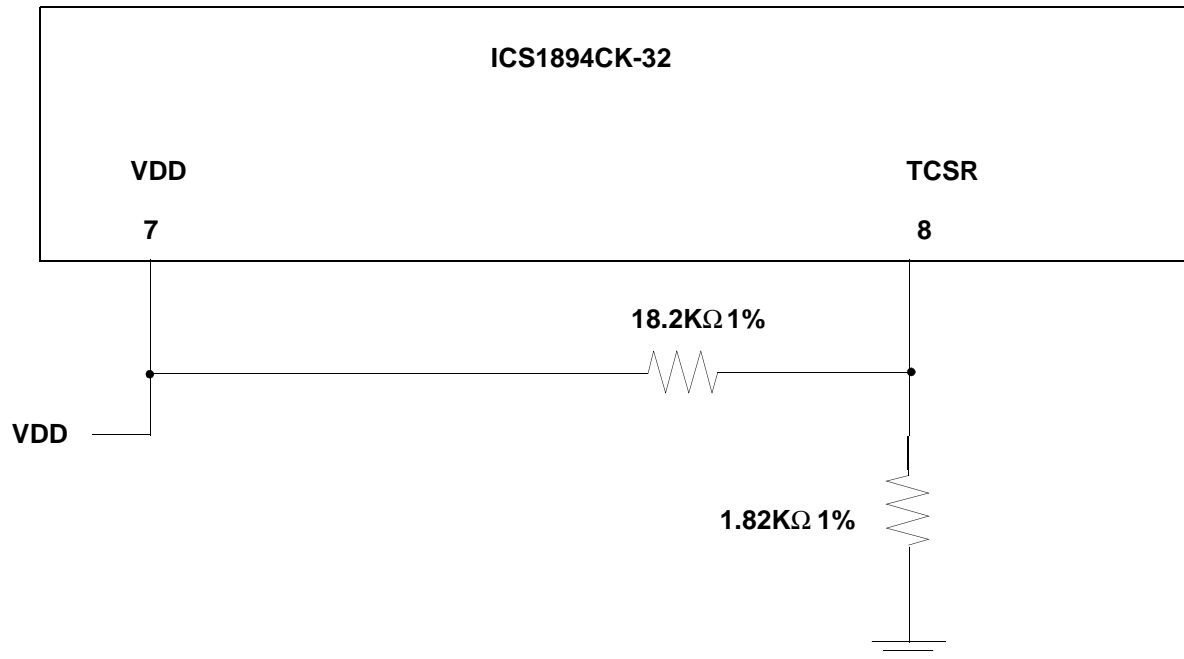

Note:

1. The bias resistor network sets the 10baseT and 100baseTX output amplitude levels.
2. Amplitude is directly related to current sourced out of the TCSR pin.
3. Resistor values shown above are typical. User should check amplitudes and adjust for transformer effects.
4. The 18.2K resistor provides negative feedback to compensate for VDD changes. Reducing the value of this resistor will lower the 100baseT amplitude. Reducing the value of the resistor to ground on the other hand will increase the output signal amplitude.

DC Operating Characteristics for Supply Current

The table below lists the DC operating characteristics for the supply current to the ICS1894-32 under various conditions.

Condition	VDDIO (V)	VDD and VDDD (V)	Current (mA) (typical)
Autonegotiation	3.3	3.3	68
	1.8	3.3	66
100BaseTX FD and Linked	3.3	3.3	102
10BaseTX FD and Linked	3.3	3.3	97
Power Down (Reg0:11 = 1)	3.3	3.3	16

Deep Power Down Current Consumption Table

		Case 1	Case 2	Case 3	Case 4	Case 5
Register 24:8	DPD Enable	√	√	√	√	√
Register 24:7	TPLL_100 DPD Enable		√	√	√	√
Register 24:6	RX_100 DPD Enable			√	√	√
Register 24:5	Admix_TX DPD Enable				√	√
Register 24:4	CDR100_cdr DPD Enable					√
Current (mA) (typical)		68	39	26	24	16

DC Operating Characteristics for Inputs and Outputs

Unless otherwise specified, the table below lists the 3.3V/1.8 V DC operating characteristics of the ICS1894-32 inputs and outputs.

For 3.3 V Signals

Parameter	Symbol	Conditions	Min.	Max.	Units
Input High Voltage	V_{IH}		2.0	–	V
Input Low Voltage	V_{IL}		–	0.8	V
Output High Voltage	V_{OH}	$I_{OH} = -4$ mA	2.4	–	V
Output Low Voltage	V_{OL}	$I_{OL} = +4$ mA	–	0.4	V

For 1.8 V Signals

Parameter	Symbol	Conditions	Min.	Max.	Units
Input High Voltage	V_{IH}		0.8	–	V
Input Low Voltage	V_{IL}		–	0.7	V
Output High Voltage	V_{OH}	$I_{OH} = -4$ mA	1.6	–	V
Output Low Voltage	V_{OL}	$I_{OL} = +4$ mA	–	0.1	V

DC Operating Characteristics for REFIN

The table below lists the 3.3V DC characteristics for the REFIN pin.

Parameter	Symbol	Min.	Max.	Units
Input High Voltage	V_{IH}	2.97	–	V
Input Low Voltage	V_{IL}	–	0.33	V

DC Operating Characteristics for MII Pins

The table below lists DC operating characteristics for the Media Independent Interface (MII) for the ICS1894-32.

Parameter	Conditions	Min.	Typ.	Max.	Units
MII Input Pin Capacitance	–	–	–	8	pF
MII Output Pin Capacitance	–	–	–	14	pF
MII Output Drive Impedance	VDDIO = 3.3V	–	20	–	Ω

Timing Diagrams

Timing for Clock Reference (REFIN) Pin

The table below lists the significant time periods for signals on the clock reference (REFIN) pin. The *REFIN Timing Diagram* figure shows the timing diagram for the time periods.

Time Period	Parameter	Conditions	Min.	Typ.	Max.	Units
t1	REFIN Duty Cycle (MII)	–	45	50	55	%
t2	REFIN Period (MII)	–	–	40	–	ns
t1	REFIN Duty Cycle (RMII)	–	45	50	55	%
t2	REFIN Period (RMII)	–	–	20	–	ns

REFIN Timing Diagram

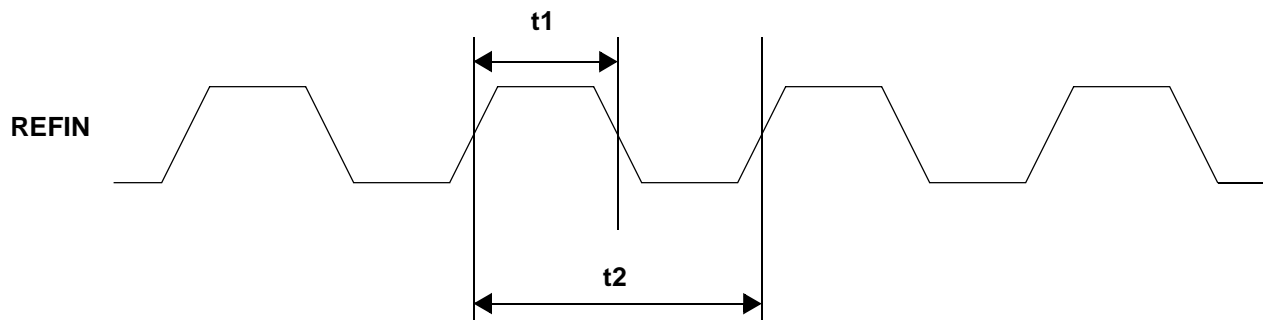

Timing for Transmit Clock (TXCLK) Pin

The table below lists the significant time periods for signals on the Transmit Clock (TXCLK) pin. The *Transmit Clock Timing Diagram* figure shows the timing diagram for the time periods.

Time Period	Parameter	Conditions	Min.	Typ.	Max.	Units
t1	TXCLK Duty Cycle	–	35	50	65	%
t2a	TXCLK Period	100M MII (100Base-TX)	–	40	–	ns
t2b	TXCLK Period	10M MII (10Base-T)	–	400	–	ns

Transmit Clock Timing Diagram

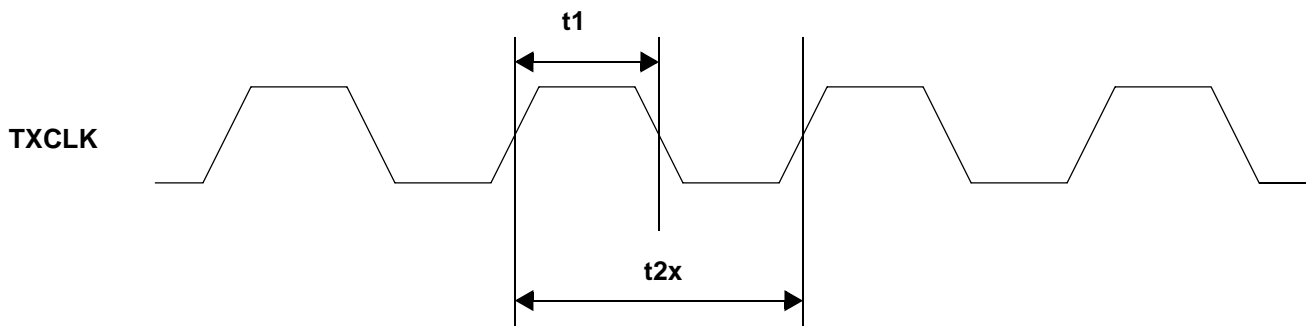

Timing for Receive Clock (RXCLK) Pin

The table below lists the significant time periods for signals on the Receive Clock (RXCLK) pin. The *Receive Clock Timing Diagram* figure shows the timing diagram for the time periods.

Time Period	Parameter	Conditions	Min.	Typ.	Max.	Units
t1	RXCLK Duty Cycle	–	35	50	65	%
t2a	RXCLK Period	100M MII (100Base-TX)	–	40	–	ns
t2b	RXCLK Period	10M MII (10Base-T)	–	400	–	ns

Receive Clock Timing Diagram

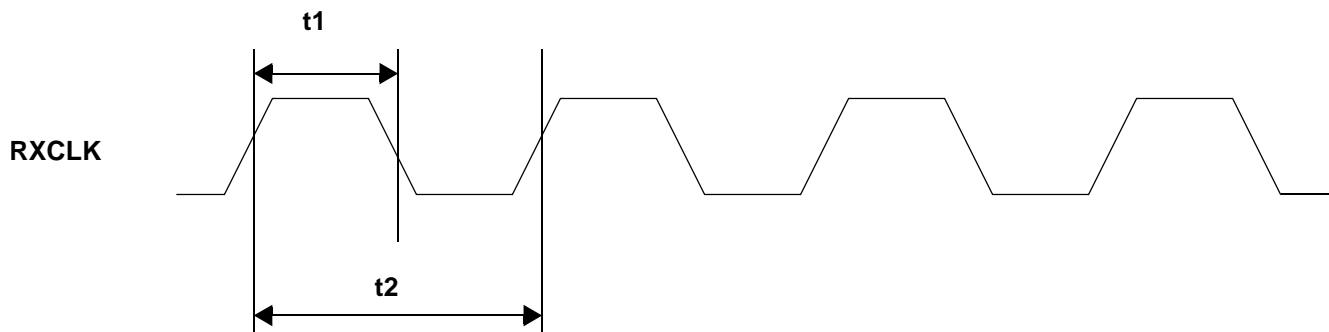

100M MII: Synchronous Transmit Timing

The table below lists the significant time periods for the 100M MII Interface synchronous transmit timing. The time periods consist of timings of signals on the following pins:

- TXCLK
- TXD[3:0]
- TXEN
- TXER

The *100M MII/100M Stream Interface Synchronous Transmit Timing Diagram* figure shows the timing diagram for the time periods.

Time Period	Parameter	Conditions	Min.	Typ.	Max.	Units
t1	TXD[3:0], TXEN, TXER Setup to TXCLK Rise	–	15	–	–	ns
t2	TXD[3:0], TXEN, TXER Hold after TXCLK Rise	–	0	–	–	ns

100M MII/100M Stream Interface Synchronous Transmit Timing Diagram

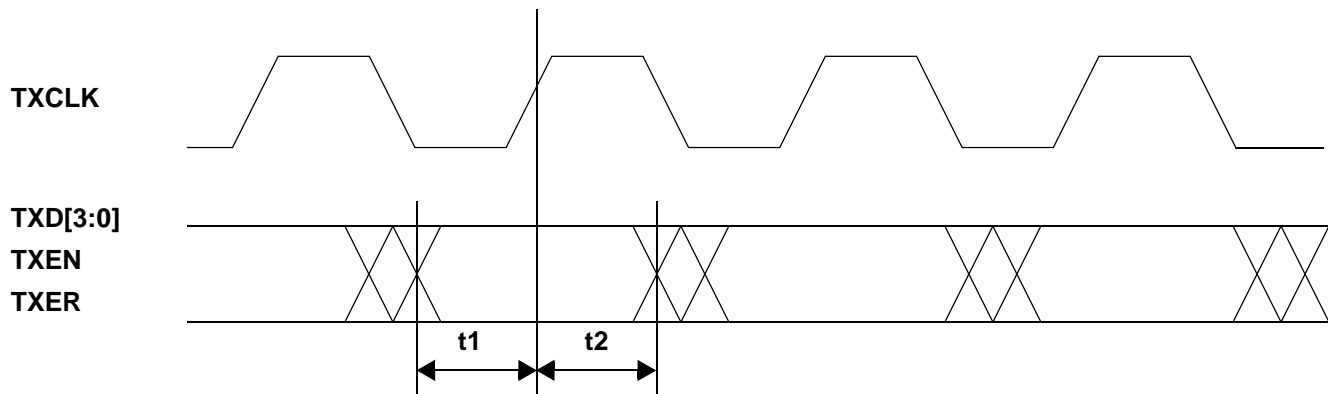

10M MII: Synchronous Transmit Timing

The table below lists the significant time periods for the 10M MII synchronous transmit timing. The time periods consist of timings of signals on the following pins:

- TXCLK
- TXD[3:0]
- TXEN
- TXER

The *10M MII Synchronous Transmit Timing Diagram* figure shows the timing diagram for the time periods.

Time Period	Parameter	Conditions	Min.	Typ.	Max.	Units
t1	TXD[3:0], TXEN, TXER Setup to TXCLK Rise	–	375	–	–	ns
t2	TXD[3:0], TXEN, TXER Hold after TXCLK Rise	–	0	–	–	ns

10M MII Synchronous Transmit Timing Diagram

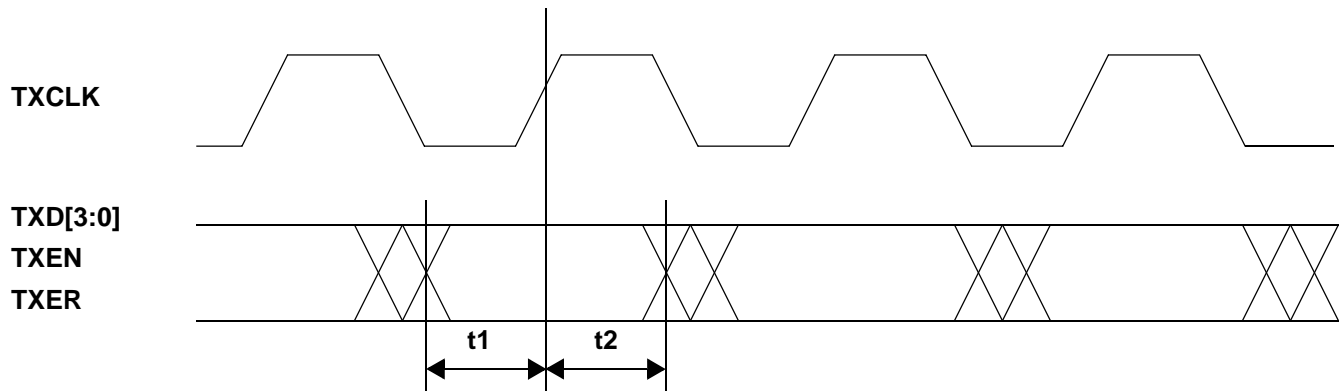

100M/MII Media Independent Interface: Synchronous Receive Timing

The table below lists the significant time periods for the MII/100M Stream Interface synchronous receive timing. The time periods consist of timings of signals on the following pins:

- RXCLK
- RXD[3:0]
- RXDV
- RXER

The *MII Interface: Synchronous Receive Timing* figure shows the timing diagram for the time periods.

Time Period	Parameter	Min.	Typ.	Max.	Units
t1	RXD[3:0], RXDV, and RXER Setup to RXCLK Rise	10.0	–	–	ns
t2	RXD[3:0], RXDV, and RXER Hold after RXCLK Rise	10.0	–	–	ns

MII Interface: Synchronous Receive Timing

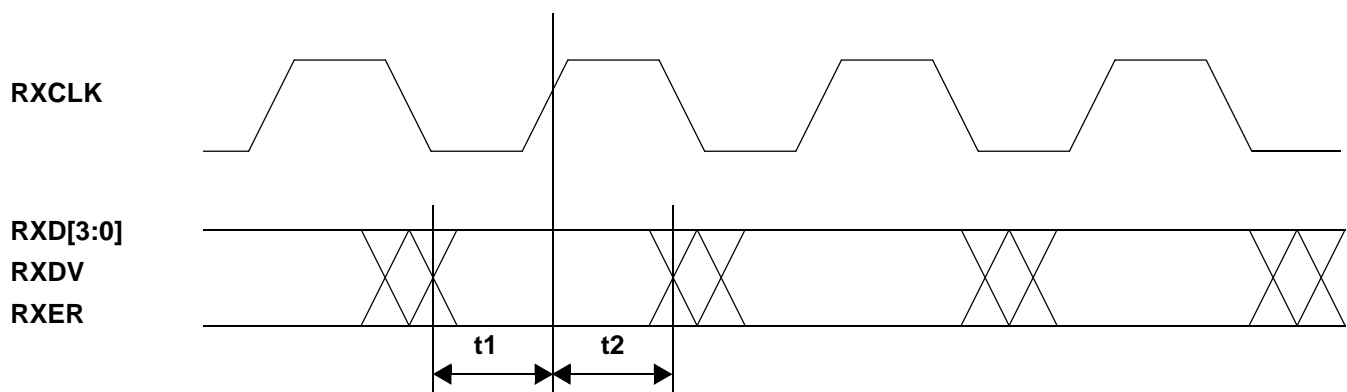

MII Management Interface Timing

The table below lists the significant time periods for the MII Management Interface timing (which consists of timings of signals on the MDC and MDIO pins). The *MII Management Interface Timing Diagram* figure shows the timing diagram for the time periods.

Time Period	Parameter	Conditions	Min.	Typ.	Max.	Units
t1	MDC Minimum High Time	–	160	–	–	ns
t2	MDC Minimum Low Time	–	160	–	–	ns
t3	MDC Period	–	400	–	–	ns
t4	MDC Rise Time to MDIO Valid	–	0	–	300	ns
t5	MDIO Setup Time to MDC	–	10	–	–	ns
t6	MDIO Hold Time after MDC	–	10	–	–	ns

MII Management Interface Timing Diagram

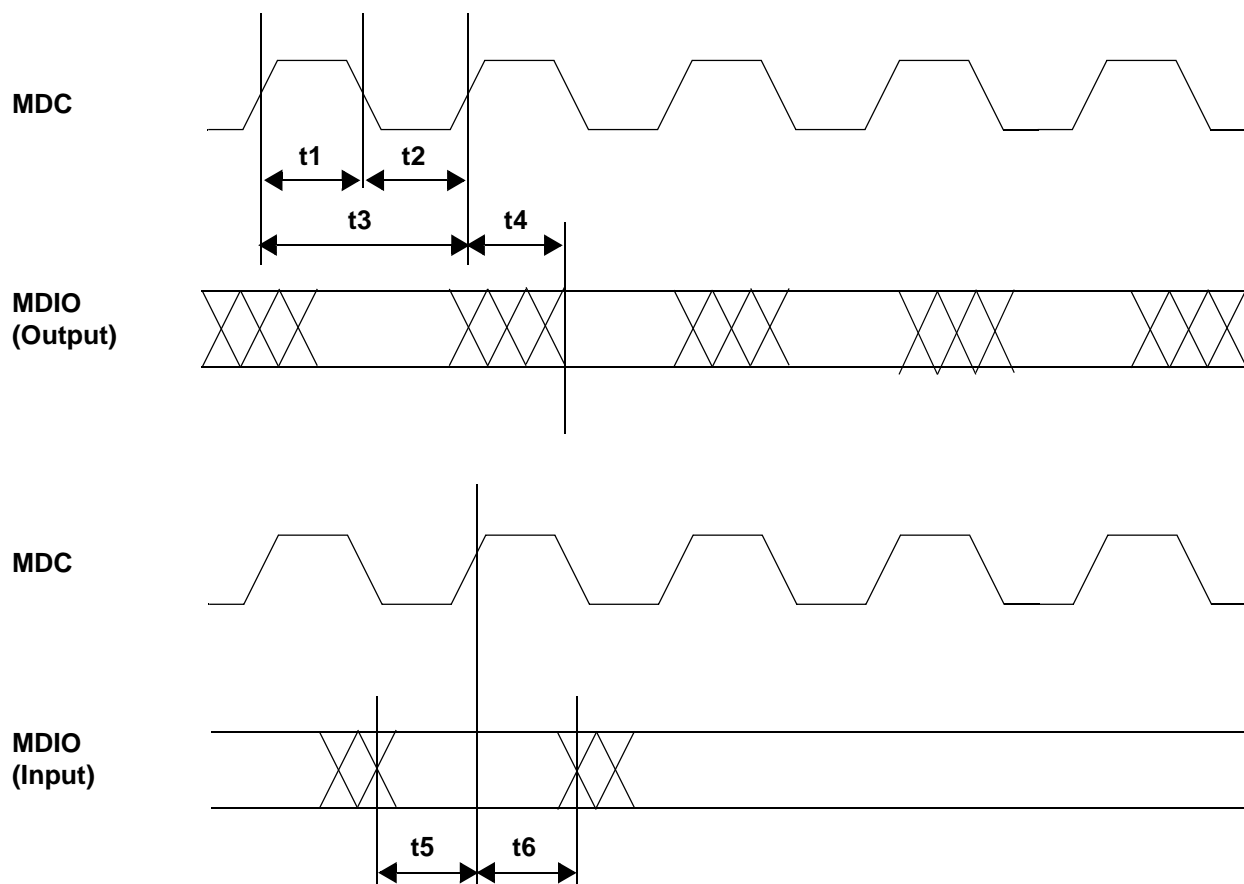

10M Media Independent Interface: Receive Latency

The table below lists the significant time periods for the 10M MII timing. The time periods consist of timings of signals on the following pins:

- TP_RX (that is, the MII TP_RXP and TP_RXN pins)
- RXCLK
- RXD

The *10M MII Receive Latency Timing Diagram* shows the timing diagram for the time periods.

Time Period	Parameter	Conditions	Min.	Typ.	Max.	Units
t1	First Bit of /5/ on TP_RX to /5/D/ on RXD	10M MII	–	6.5	7	Bit times

10M MII Receive Latency Timing Diagram

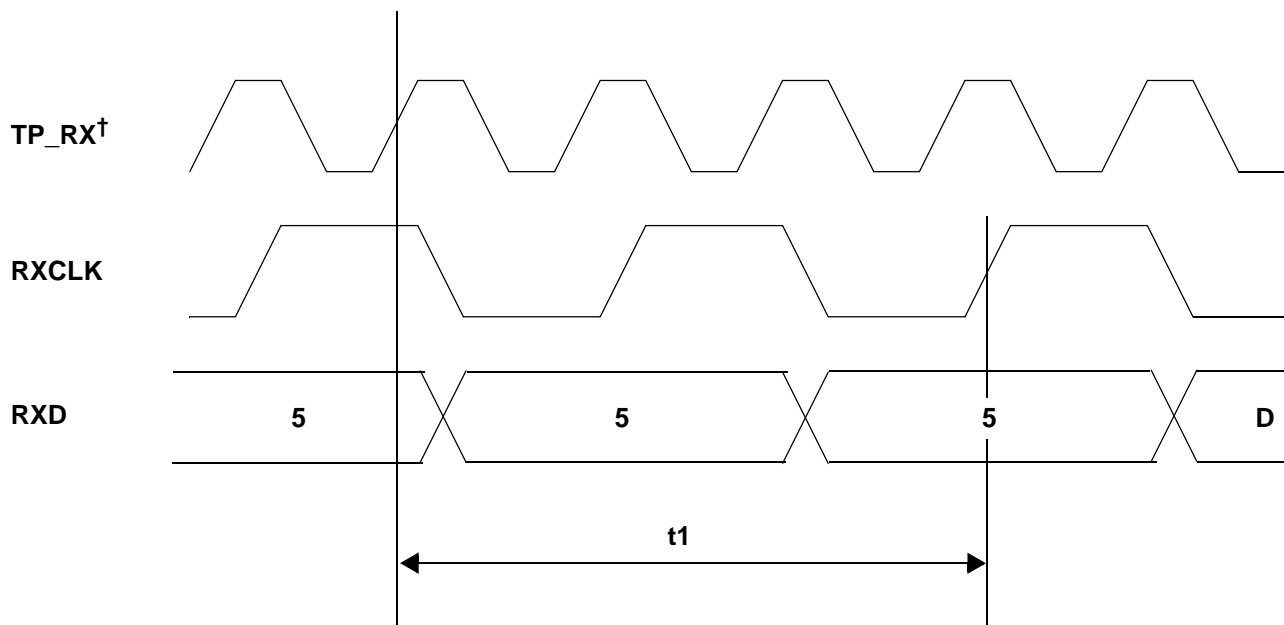

† Manchester encoding is not shown.

10M Media Independent Interface: Transmit Latency

The table below lists the significant time periods for the 10M MII transmit latency. The time periods consist of timings of signals on the following pins:

- TXEN
- TXCLK
- TXD (that is, TXD[3:0])
- TP_TX (that is, TP_TXP and TP_TXN)

The *10M MII Transmit Latency Timing Diagram* shows the timing diagram for the time periods.

Time Period	Parameter	Conditions	Min.	Typ.	Max.	Units
t1	TXD Sampled to MDI Output of First Bit	10M MII	–	1.2	2	Bit times

10M MII Transmit Latency Timing Diagram

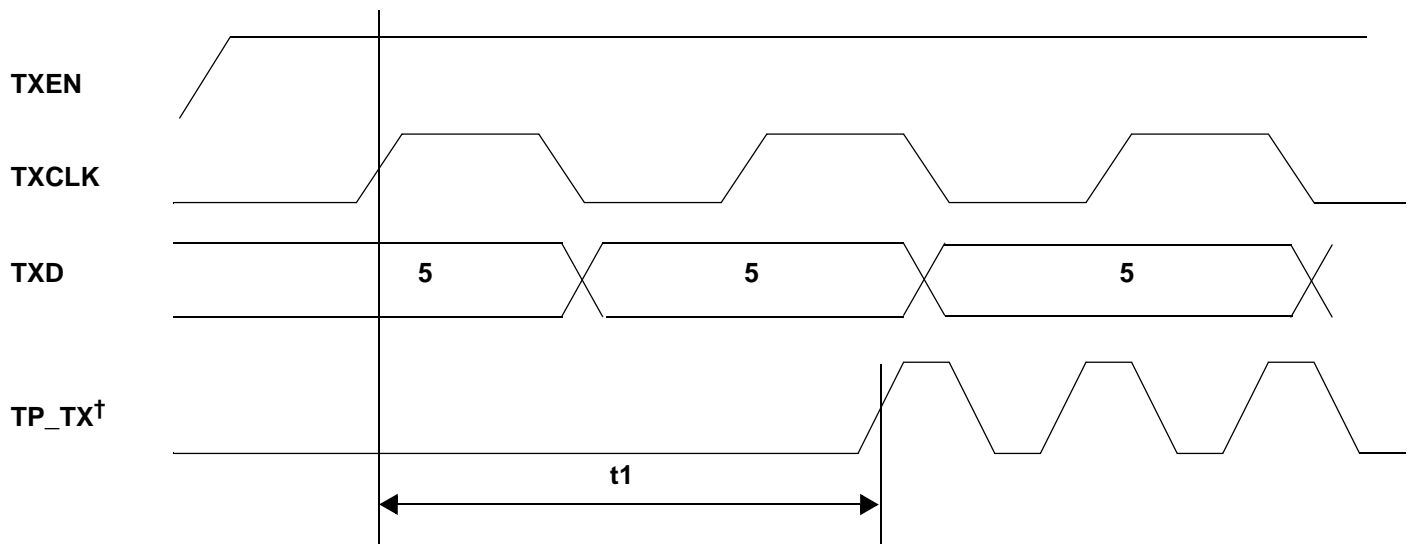

† Manchester encoding is not shown.

100M / MII Media Independent Interface: Transmit Latency

The table below lists the significant time periods for the MII/100 Stream Interface transmit latency. The time periods consist of timings of signals on the following pins:

- TXEN
- TXCLK
- TXD (that is, TXD[3:0])
- TP_TX (that is, TP_TXP and TP_TXN)

The *MII/100M Stream Interface Transmit Latency Timing Diagram* shows the timing diagram for the time periods.

Time Period	Parameter	Conditions	Min.	Typ.	Max.	Units
t1	TXEN Sampled to MDI Output of First Bit of /J/ †	MII mode	–	2.8	3	Bit times

† The IEEE maximum is 18 bit times.

MII/100M Stream Interface Transmit Latency Timing Diagram

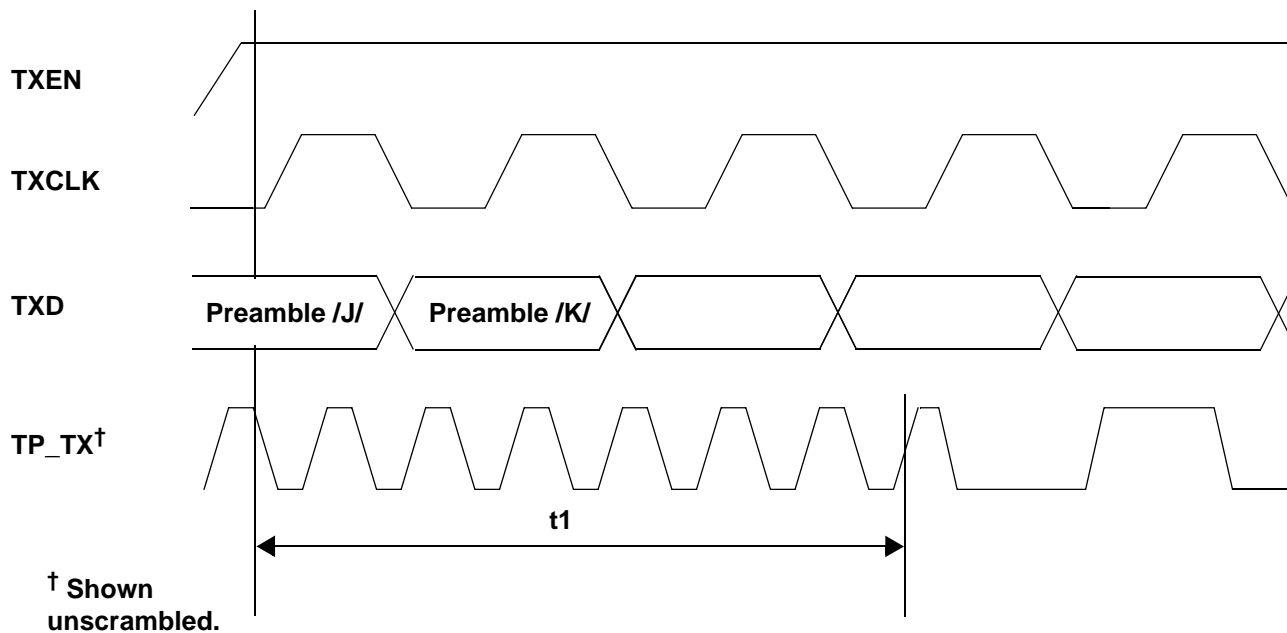

100M MII: Carrier Assertion/De-Assertion (Half-Duplex Transmission)

The table below lists the significant time periods for the 100M MII carrier assertion/de-assertion during half-duplex transmission. The time periods consist of timings of signals on the following pins:

- TXEN
- TXCLK
- CRS

The *100M MII Carrier Assertion/De-Assertion Timing Diagram (Half-Duplex Transmission Only)* shows the timing diagram for the time periods.

Time Period	Parameter	Conditions	Min.	Typ.	Max.	Units
t1	TXEN Sampled Asserted to CRS Assert		0	3	4	Bit times
t2	TXEN De-Asserted to CRS De-Asserted		0	3	4	Bit times

100M MII Carrier Assertion/De-Assertion Timing Diagram (Half-Duplex Transmission Only)

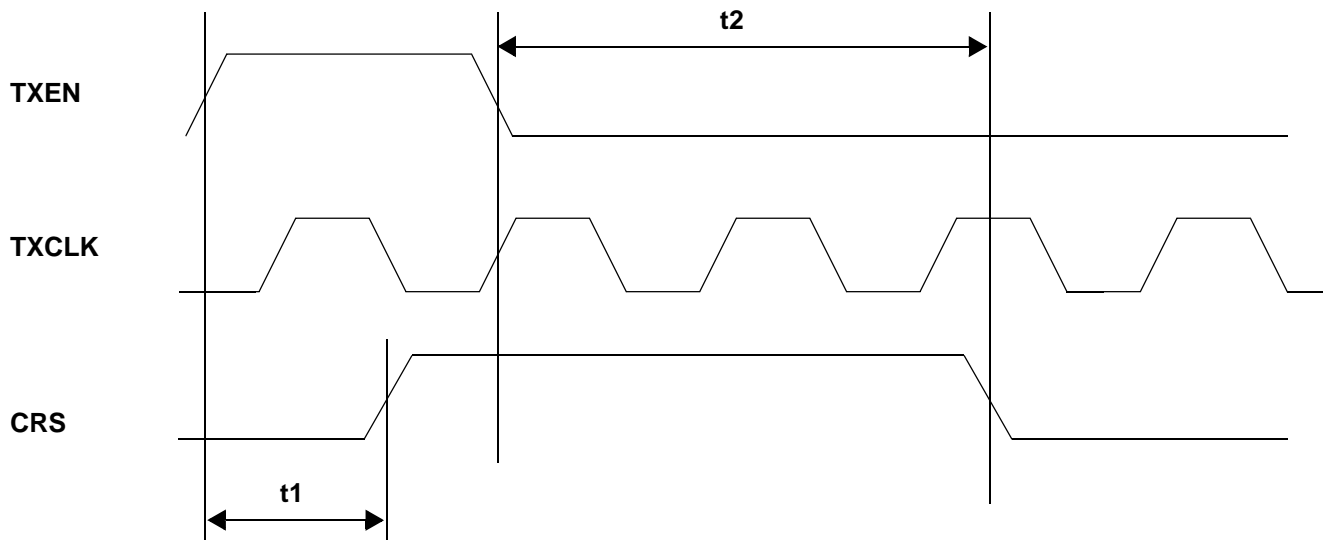

10M MII: Carrier Assertion/De-Assertion (Half-Duplex Transmission)

The table below lists the significant time periods for the 10M MII carrier assertion/de-assertion during half-duplex transmission. The time periods consist of timings of signals on the following pins:

- TXEN
- TXCLK
- CRS

The *10M MII Carrier Assertion/De-Assertion Timing Diagram (Half-Duplex Transmission Only)* shows the timing diagram for the time periods.

Time Period	Parameter	Conditions	Min.	Typ.	Max.	Units
t1	TXEN Asserted to CRS Assert		0	–	2	Bit times
t2	TXEN De-Asserted to CRS De-Asserted		0	2	4	Bit times

10M MII Carrier Assertion/De-Assertion Timing Diagram (Half-Duplex Transmission Only)

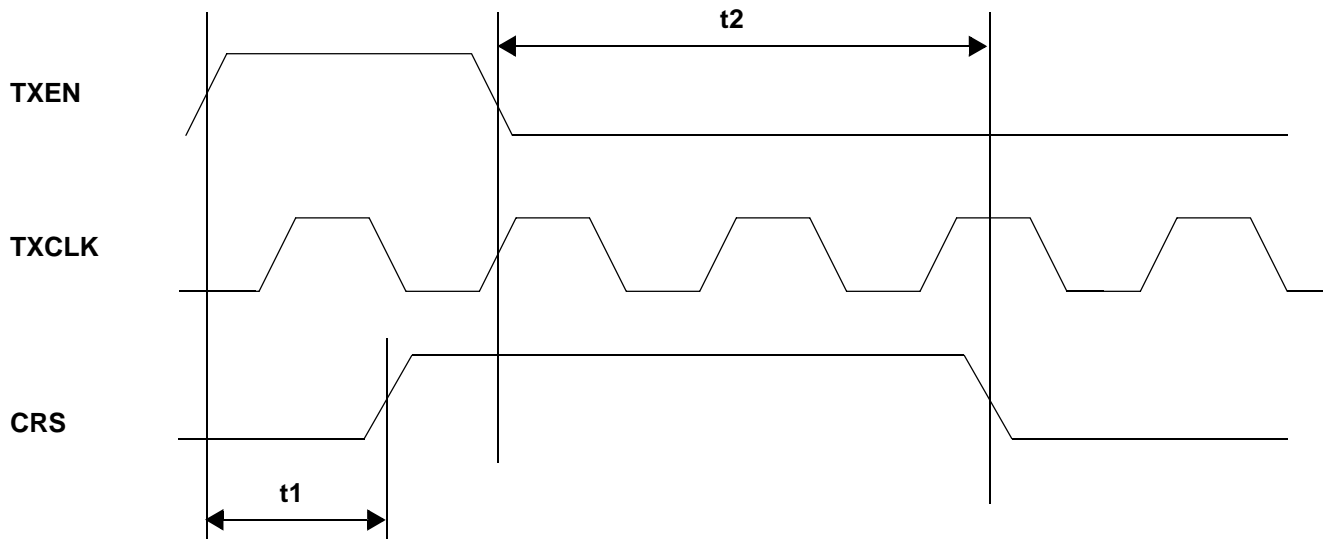

100M MII Media Independent Interface: Receive Latency

The table below lists the significant time periods for the 100M MII/100M Stream Interface receive latency. The time periods consist of timings of signals on the following pins:

- TP_RX (that is, TP_RXP and TP_RXN)
- RXCLK
- RXD (that is, RXD[3:0])

The *100M MII/100M Stream Interface: Receive Latency Timing Diagram* shows the timing diagram for the time periods.

Time Period	Parameter	Conditions	Min.	Typ.	Max.	Units
t1	First Bit of /J/ into TP_RX to /J/ on RXD	100M MII	–	16	17	Bit times

100M MII/100M Stream Interface: Receive Latency Timing Diagram

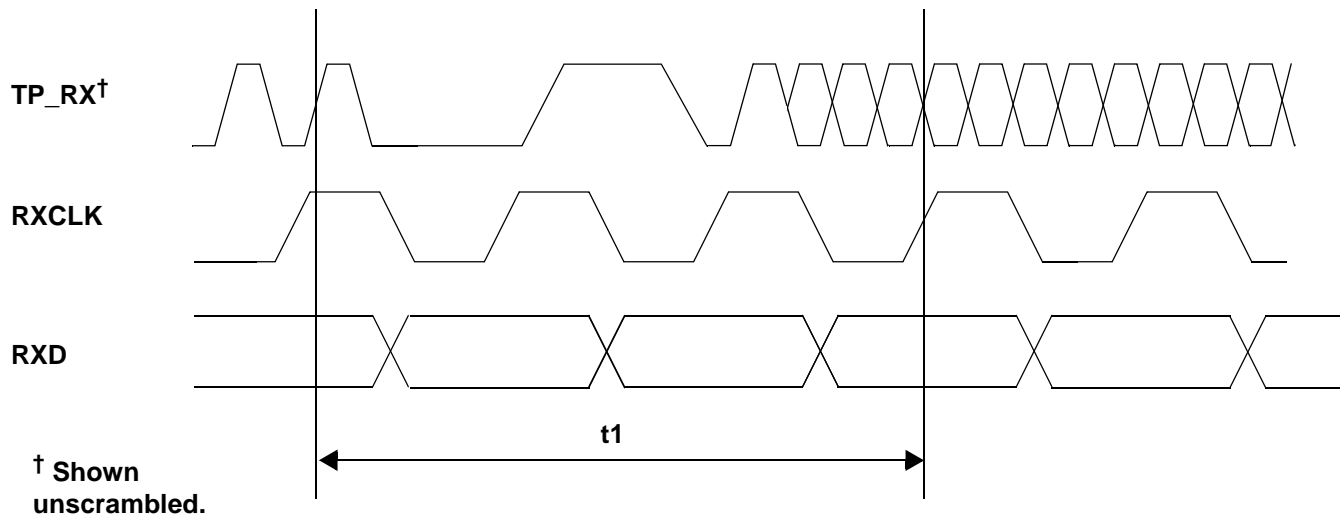

100M Media Independent Interface: Input-to-Carrier Assertion/De-Assertion

The table below lists the significant time periods for the 100M MDI input-to-carrier assertion/de-assertion. The time periods consist of timings of signals on the following pins:

- TP_RX (that is, TP_RXP and TP_RXN)
- CRS
- COL

The *100M MDI Input to Carrier Assertion/De-Assertion Timing Diagram* shows the timing diagram for the time periods.

Time Period	Parameter	Conditions	Min.	Typ.	Max.	Units
t1	First Bit of /J/ into TP_RX to CRS Assert †	–	10	–	14	Bit times
t2	First Bit of /J/ into TP_RX while Transmitting Data to COL Assert †	Half-Duplex Mode	9	–	13	Bit times
t3	First Bit of /T/ into TP_RX to CRS De-Assert ‡	–	13	–	18	Bit times
t4	First Bit of /T/ Received into TP_RX to COL De-Assert ‡	Half-Duplex Mode	13	–	18	Bit times

†The IEEE maximum is 20 bit times.

‡The IEEE minimum is 13 bit times, and the maximum is 24 bit times.

100M MDI Input to Carrier Assertion/De-Assertion Timing Diagram

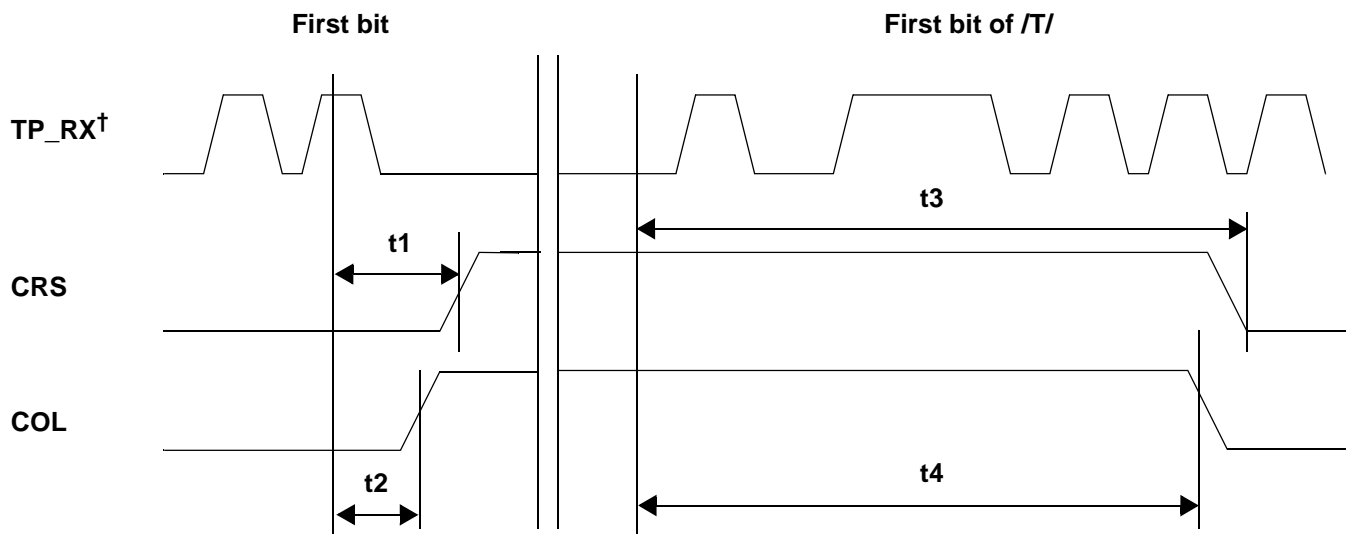

† Shown unscrambled.

Reset: Power-On Reset

The table below lists the significant time periods for the power-on reset. The time periods consist of timings of signals on the following pins:

- VDD
- TXCLK

The *Power-On Reset Timing Diagram* shows the timing diagram for the time periods.

Time Period	Parameter	Conditions	Min.	Typ.	Max.	Units
t1	VDD \geq 2.7 V to Reset Complete	–	40	45	500	ms

Power-On Reset Timing Diagram

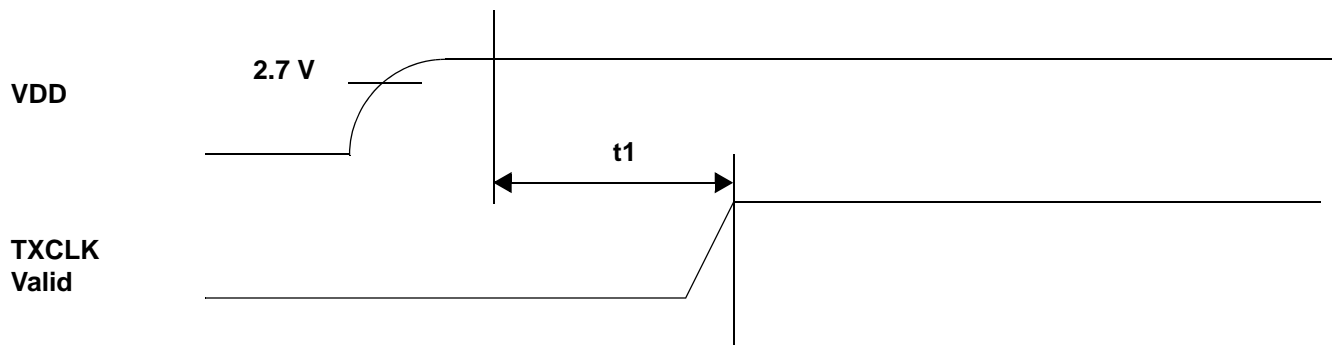

Reset: Hardware Reset and Power-Down

The table below lists the significant time periods for the hardware reset and power-down reset. The time periods consist of timings of signals on the following pins:

- REFIN
- RESETn
- TXCLK

The *Hardware Reset and Power-Down Timing Diagram* shows the timing diagram for the time periods.

Time Period	Parameter	Conditions	Min.	Typ.	Max	Units
t1	RESETn Active to Device Isolation and Initialization	–	–	60	–	ns
t2	Minimum RESETn Pulse Width	–	200		–	ns
t3	RESETn Released to TXCLK Valid	–	–	35	500	ms

Hardware Reset and Power-Down Timing Diagram

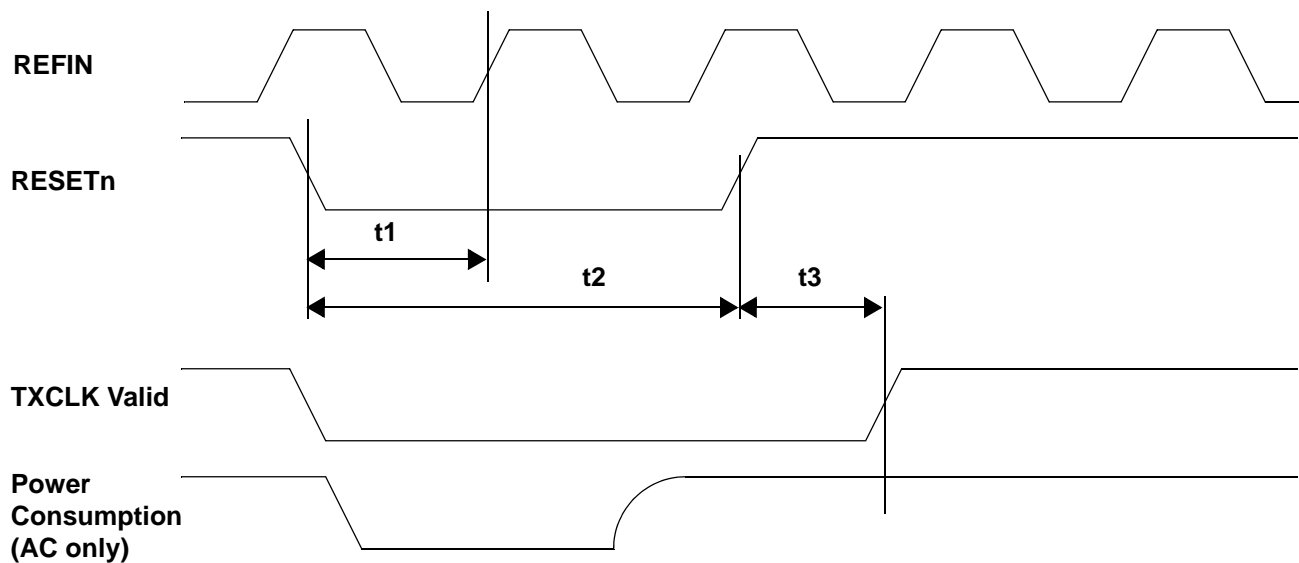

10Base-T: Heartbeat Timing (SQE)

The table below lists the significant time periods for the 10Base-T heartbeat (that is, the Signal Quality Error). The time periods consist of timings of signals on the following pins:

- TXEN
- TXCLK
- COL

The *10Base-T Heartbeat (SQE) Timing Diagram* shows the timing diagram for the time periods.

Note:

1. For more information on 10Base-T SQE operations, see the section “10Base-T Operation: SQE Test”.
2. In 10Base-T mode, one bit time = 100 ns.

Time Period	Parameter	Conditions	Min.	Typ.	Max.	Units
t1	COL Heartbeat Assertion Delay from TXEN De-Assertion	10Base-T Half Duplex	–	850	1500	ns
t2	COL Heartbeat Assertion Duration	10Base-T Half Duplex	–	1000	1500	ns

10Base-T Heartbeat (SQE) Timing Diagram

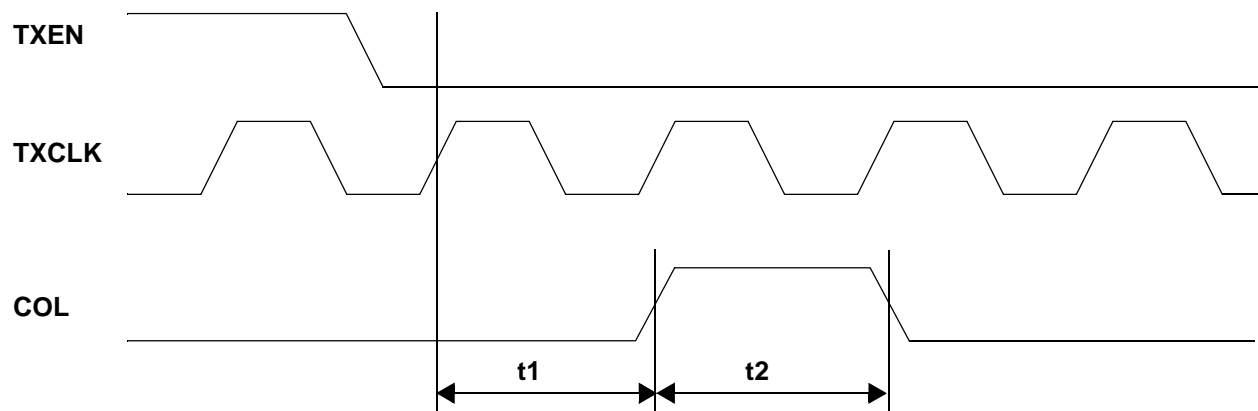

10Base-T: Jabber Timing

The table below lists the significant time periods for the 10Base-T jabber. The time periods consist of timings of signals on the following pins:

- TXEN
- TP_TX (that is, TP_TXP and TP_TXN)
- COL

The *10Base-T Jabber Timing Diagram* shows the timing diagram for the time periods.

Note: For more information on 10Base-T jabber operations, see the section, “10Base-T Operation: Jabber”.

Time Period	Parameter	Conditions	Min.	Typ.	Max.	Units
t1	Jabber Activation Time	10Base-T Half Duplex	20	–	35	ms
t2	Jabber De-Activation Time	10Base-T Half Duplex	300	–	325	ms

10Base-T Jabber Timing Diagram

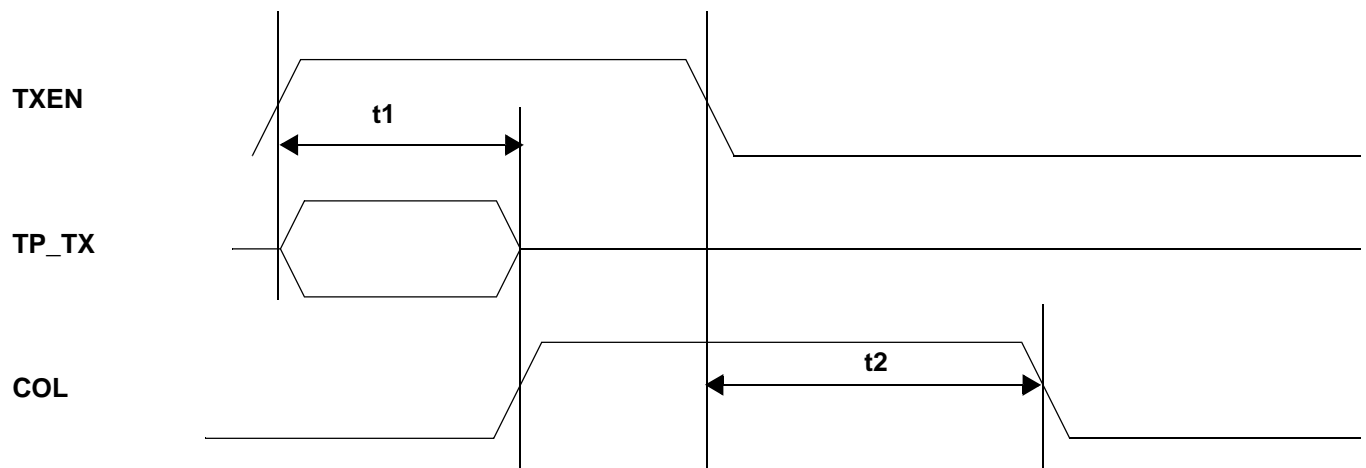

10Base-T: Normal Link Pulse Timing

The table below lists the significant time periods for the 10Base-T Normal Link Pulse (which consists of timings of signals on the TP_TXP pins). The *10Base-T Normal Link Pulse Timing Diagram* shows the timing diagram for the time periods.

Time Period	Parameter	Conditions	Min.	Typ.	Max.	Units
t1	Normal Link Pulse Width	10Base-T	–	100	–	ns
t2	Normal Link Pulse to Normal Link Pulse Period	10Base-T	8	20	25	ms

10Base-T Normal Link Pulse Timing Diagram

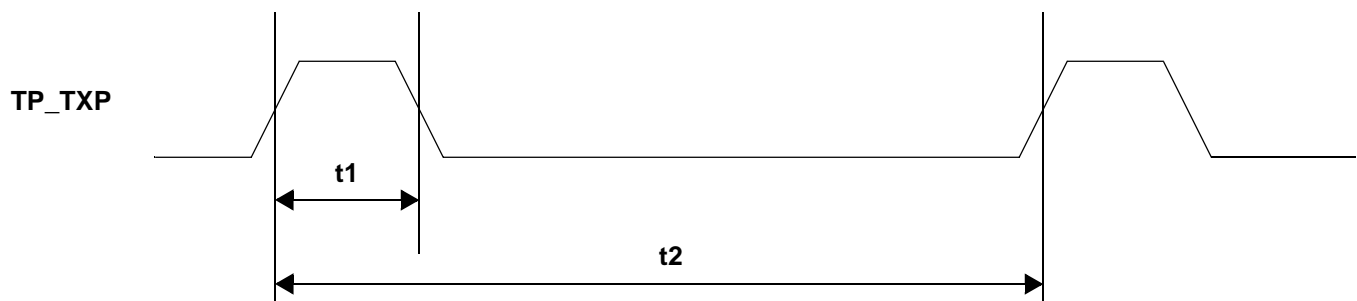

Auto-Negotiation Fast Link Pulse Timing

The table below lists the significant time periods for the ICS1894-32 Auto-Negotiation Fast Link Pulse. The time periods consist of timings of signals on the following pins:

- TP_TXP
- TP_TXN

The *Auto-Negotiation Fast Link Pulse Timing Diagram* shows the timing diagram for one pair of these differential signals, for example TP_TXP minus TP_TXN.

Time Period	Parameter	Conditions	Min.	Typ.	Max.	Units
t1	Clock/Data Pulse Width	–	–	90	–	ns
t2	Clock Pulse-to-Data Pulse Timing	–	55	60	70	μs
t3	Clock Pulse-to-Clock Pulse Timing	–	110	125	140	μs
t4	Fast Link Pulse Burst Width	–	–	5	–	ms
t5	Fast Link Pulse Burst to Fast Link Pulse Burst	–	10	15	25	ms
t6	Number of Clock/Data Pulses in a Burst	–	15	20	30	pulses

Auto-Negotiation Fast Link Pulse Timing Diagram

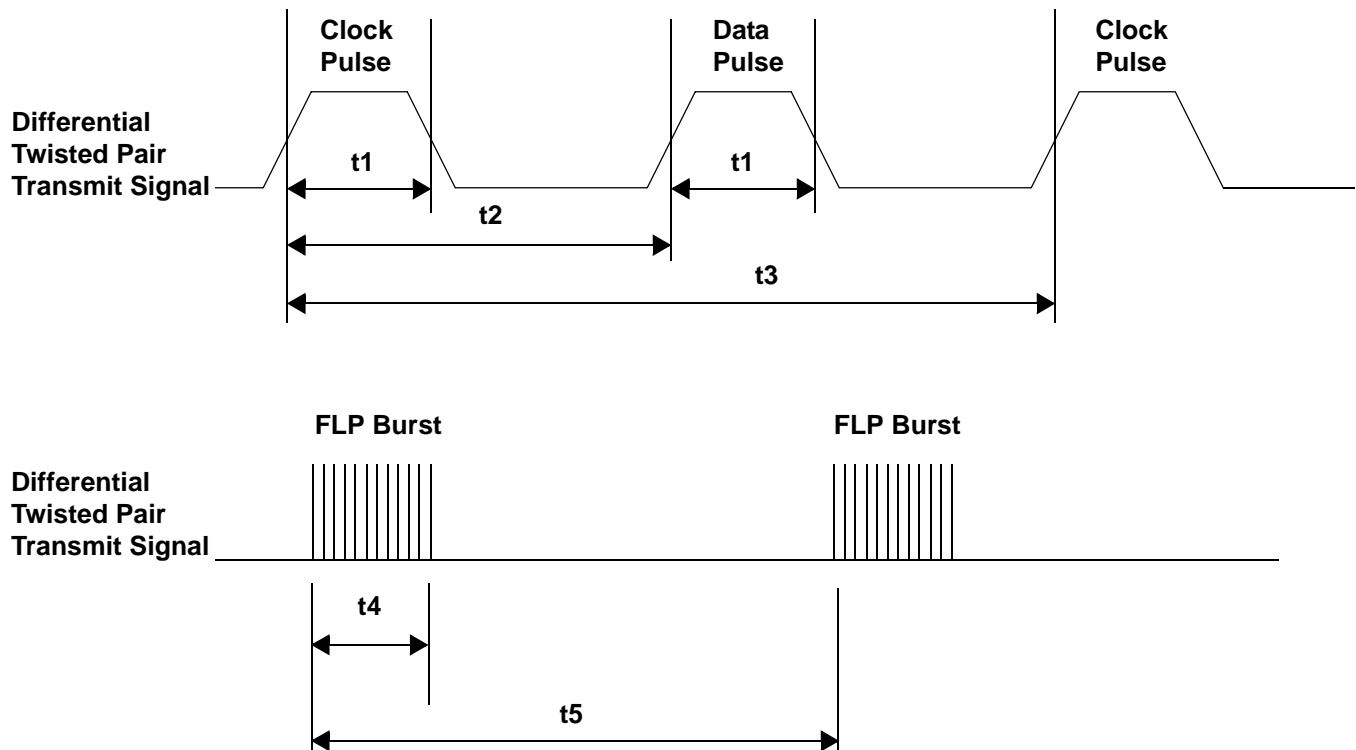

RMII Timing

Time Param	Description	Min.	Typ.	Max.	Units
tcyc	Clock Cycle	–	20		ns
t1	Setup time	4			ns
t2	Hold time	2			ns

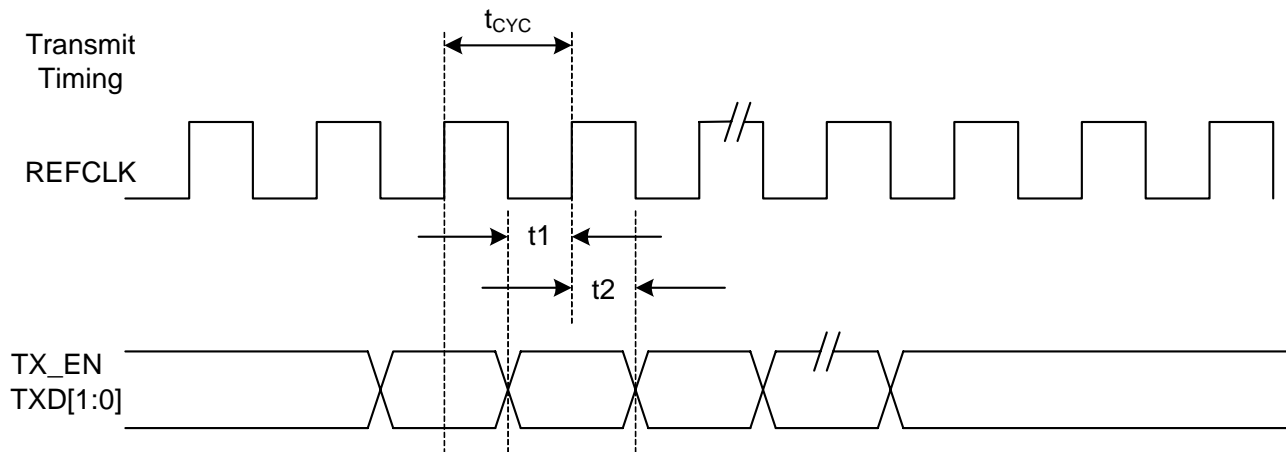

Marking Diagram

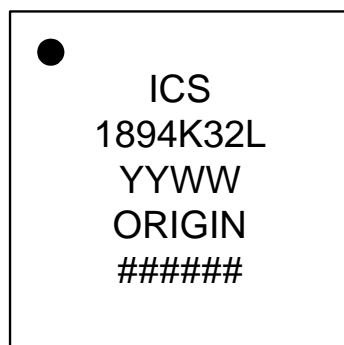

Notes:

1. 'L' designates Pb (lead) free, RoHS compliant.
1. 'YYWW' designates date code.
2. 'ORIGIN' designates country of origin.
3. '#####' designates the lot number.

Package Outline and Package Dimensions (32-pin 5mm x 5mm QFN)

Package dimensions are kept current with JEDEC Publication No. 95

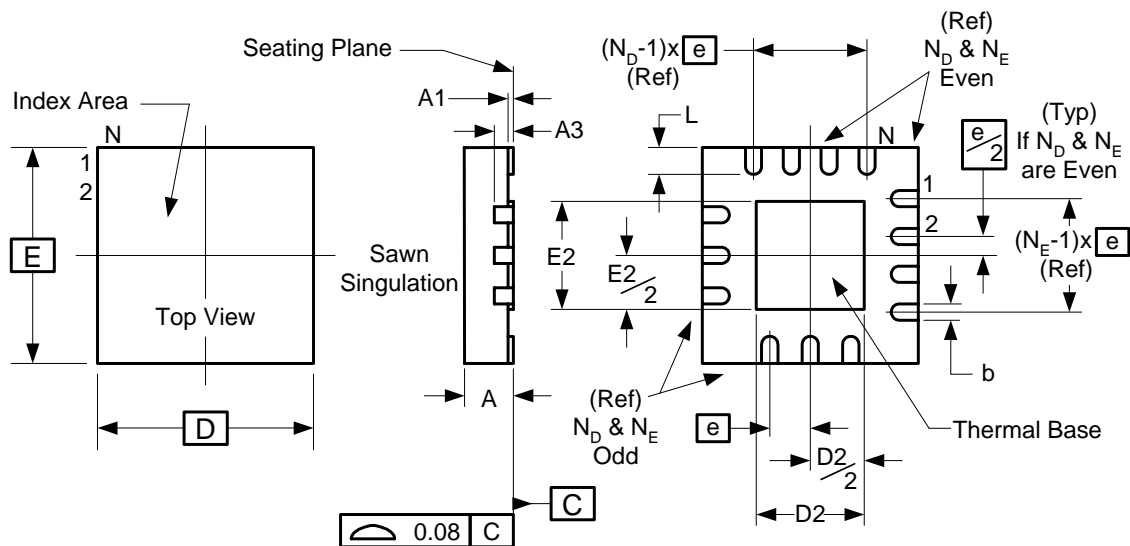

Symbol	Millimeters	
	Min	Max
A	0.80	1.00
A1	0	0.05
A3	0.20 Reference	
b	0.18	0.30
e	0.50 BASIC	
N	32	
N_D	8	
N_E	8	
D x E BASIC	5.00 x 5.00	
D2	3.00	3.3
E2	3.00	3.3
L	0.3	0.5

Ordering Information

Part / Order Number	Marking	Shipping Packaging	Package	Temperature
1894-32KLF	see page 52	Tubes	32-pin QFN	0 to +70° C
1894-32KLFT		Tape and Reel	32-pin QFN	0 to +70° C

"LF" suffix to the part number are the Pb-Free configuration and are RoHS compliant.

While the information presented herein has been checked for both accuracy and reliability, Integrated Device Technology (IDT) assumes no responsibility for either its use or for the infringement of any patents or other rights of third parties, which would result from its use. No other circuits, patents, or licenses are implied. This product is intended for use in normal commercial applications. Any other applications such as those requiring extended temperature range, high reliability, or other extraordinary environmental requirements are not recommended without additional processing by IDT. IDT reserves the right to change any circuitry or specifications without notice. IDT does not authorize or warrant any IDT product for use in life support devices or critical medical instruments.

Innovate with IDT and accelerate your future networks. Contact:

www.IDT.com

For Sales

800-345-7015
408-284-8200
Fax: 408-284-2775

For Tech Support

www.idt.com/go/clockhelp

Corporate Headquarters

Integrated Device Technology, Inc.
www.idt.com



www.IDT.com