



Z02215

SINGLE-CHIP MODEM WITH INTEGRATED CONTROLLER, DATA PUMP, AND ANALOG FRONT END

FEATURES

- Complete modem Integrated Circuit with integrated controller, data pump and Analog Front End (AFE) with active hybrid
- Includes an AT command set interpreter in the on-chip ROM with no external memory required
- Interface to serial EEPROM allows configuration of controller code through the Diplomat™ utility that simplifies country qualifications
- Automatic determination of AT command speed and parity
- Includes V.14 asynchronous to synchronous conversion
- Accepts asynchronous or synchronous terminal data
- Speed matching and RTC/CTS flow control between the modem and the terminal
- Voice answer detection
 - Line-In-Use detection before connection
 - Pick-up detection during connections
- Supports Tone or Pulse dialing
- Call progress monitoring controls
- Guard tone controls
- Line quality monitoring and auto-retrain
- Auto-Dial and Auto-Answer
- Supports telephone dial blacklisting
- Data modem throughput to 2400 bps
 - ITU V.22bis, V.23, V.22, V.21
 - Bell 212A, Bell 103, Bell 202, Bell 202T
- FSK (V.23 1200/75 bps, Bell 202/Bell 202T 1200/150 bps, V.21/Bell 103 300 bps), DPSK (V.22/Bell 212A 1200 bps), or QAM Encoding (V.22bis 2400 bps)
- V.23 with Minitel line reversal
- Programmable bi-quad call progress tone detectors
- Adaptive equalization to compensate for a wide variety of line conditions
- Programmable transmit attenuation and selectable receive threshold
- Fully-programmable call progress detectors for precise call program monitoring, including signal quality detectors, tone detectors, tone generators, and transmit signal levels that aid in rapid country qualifications
- On-chip peripheral, a full-duplex voice band AFE with 12-bit resolution
- Dynamic power management: power-saving SLEEP modes
- North American Type-I Caller ID
- 44-Pin PLCC, 44-Pin VQFP footprint
- Single +5 VDC power supply
- Minimal external logic
- 0°C to +70°C standard temperature range and –40°C to +85°C extended temperature range

Note: International Telecommunications Union (ITU, formerly known as CCITT)

GENERAL DESCRIPTION

The Z02215 is a synchronous single-chip V.22bis modem capable of 2400 bps full-duplex over dial-up lines. It is a full-featured, self-controlled modem that includes a modem controller, DSP, and Analog Front End (AFE) functions. This device is specifically designed for use in embedded modem applications where space, performance, and low-power consumption are key requirements.

Operating over the Public Switched Telephone Network (PSTN), the Z02215 meets the modem standards for V.22bis, V.22, V.23 (Minitel), V.21, Bell 212A, Bell 202, Bell 202T, and Bell 103.

A typical modem can be created by simply adding a phone-line interface (DAA), and DTE interface.

All modulation, demodulation, filtering, Analog to Digital (A/D), and Digital to Analog (D/A) conversion functions for transmission and reception are provided on-chip. Automatic compromise equalizers are included to optimize performance over a wide range of line types.

The Z02215 device compensates for a wide variety of adverse line conditions by using adaptive equalizers.

The Z02215 provides comprehensive selectable and programmable tone generation and detection.

Transmit drivers and receive amplifiers can be connected directly to a Data Access Arrangement (DAA) by adding a transformer, or a silicon DAA, reducing the external circuits to a minimum.

In addition, the Z02215 provides further system-level savings by providing built-in filters for both the transmitter analog output and the receiver analog Input. This configuration eliminates the need for external filtering components.

The analog front end of the Z02215 includes an active hybrid circuit that improves modem performance and reduces system-level costs by reducing the requirement for external components.

The Z02215 device operates on a single +5 VDC power supply. During periods of no traffic, the modem can be placed into SLEEP mode, reducing power consumption through Dynamic Power Management.

Note: All signals with an overline, are active Low. For example, $\overline{B/W}$, in which WORD is active Low; and $\overline{B/W}$, in which BYTE is active Low.

Power connections follow these conventional descriptions:

Connection	Circuit	Device
Power	V _{CC}	V _{DD}
Ground	GND	V _{SS}

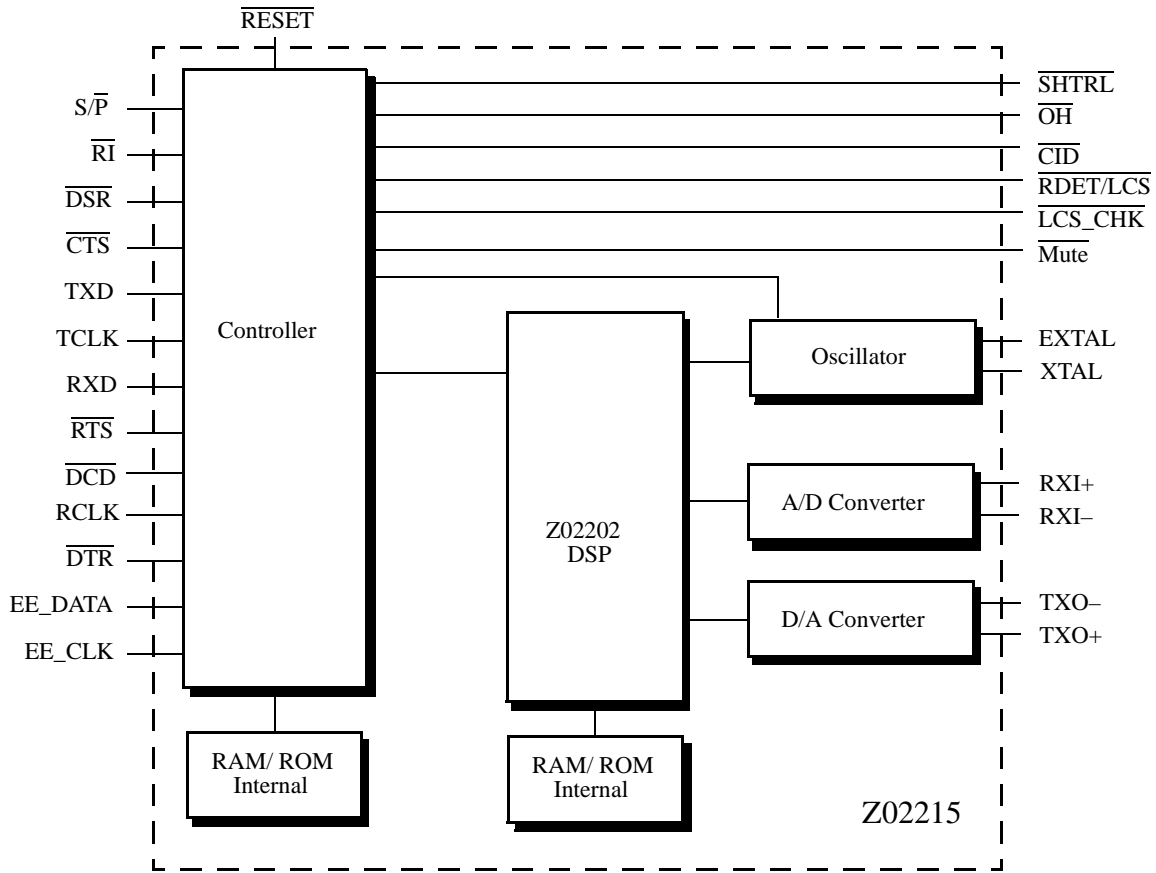

Figure 1. Z02215 Block Diagram

PIN DESCRIPTIONS

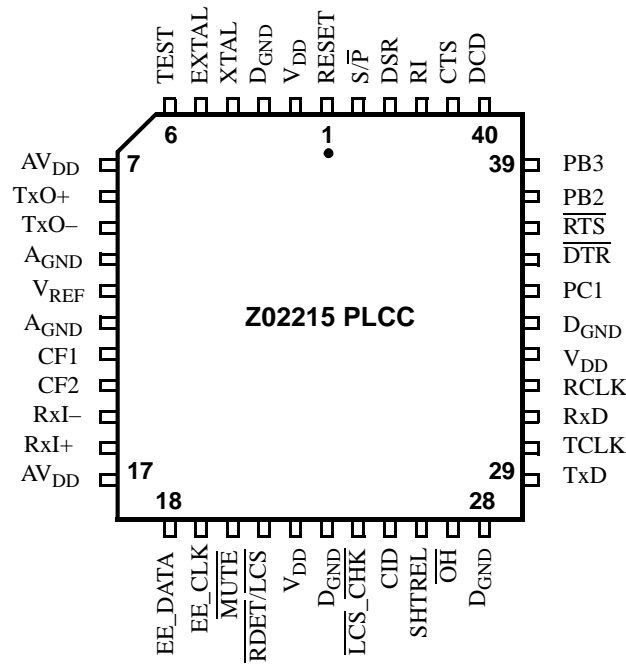

Figure 2. Z02215 44-Lead PLCC Pin Identification

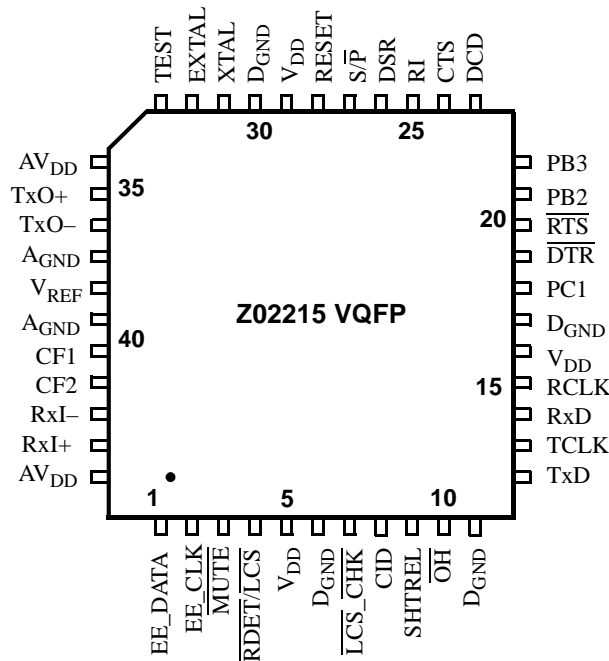

Figure 3. Z02215 44-Lead VQFP Pin Identification

Table 1. Pin Descriptions

Symbol	PLCC Pin #	VQFP Pin #	Function	Direction	Description
$\overline{\text{RESET}}$	1	28	Reset (Active low)	Input, Output	The RESET signal sets the modem to a RESET state.
V_{DD}	2	29	Digital Power		
D_{GND}	3	30	Digital Ground		
XTAL	4	31	Crystal (Time-based Output)	Output	This pin connects a parallel-resonant crystal. This pin is left open if an external clock is used instead of a crystal.
EXTAL	5	32	Crystal (Time-based Output)	Input	This pin connects a parallel-resonant crystal. An external clock can be input to the device on this pin when a crystal is not used.
TEST	6	33		Input	This pin is a test pin that must be tied to digital ground.
AV_{DD}	7	34	Analog Power		
TXO+	8	35	Transmit Differential Analog Output Positive	Analog Output	The TXO+ is capable of driving a 600W resistive load over a leased line or public switched telephone network via a Data Access Arrangement (DAA).
TXO-	9	36	Transmit Differential Analog Output Negative	Analog Output	The TXO+ is capable of driving a 600W resistive load over a leased line or public switched telephone network via a Data Access Arrangement (DAA).
A_{GND}	10	37	Analog Ground		
V_{REF}	11	38	Reference Voltage active High	Analog Output	An internally generated DC voltage.
A_{GND}	12	39	Analog Ground		
CF1	13	40	Integration Capacitor PIN 1	Analog Input	Connect an 82pF capacitor between CF2 and CF1 to complete the internal feedback integration filter for improved analog A/D performance.
CF2	14	41	Integration Capacitor PIN 2	Analog Input	Connect an 82pF capacitor between CF2 and CF1 to complete the internal feedback integration filter for improved analog A/D performance.
RXI-	15	42	Receive Differential Analog Output Negative	Analog Input	These are the analog inputs from the DAA.
RXI+	16	43	Receive Differential Analog Output Positive	Analog Input	These are the analog inputs from the DAA.
AV_{DD}	17	44	Analog Power		
EE_DATA	18	1		Input/Output	I ² C EEPROM Data.
EE_CLK	19	2		Output	I ² C EEPROM Clock.
$\overline{\text{MUTE}}$	20	3	Speaker Mute Control	Input	Controls speaker muting.
$\overline{\text{RDET/LCS}}$	21	4	Ring Detect Input Line Current Sense	Input	Signals the presence of a ring signal on the line. The LCS_CHK input is used to detect when a parallel phone is off-hook before dialing or when a parallel phone has been picked up while connected. In either case when LCS goes Low, the connection attempt is dropped with a NO CARRIER message.
V_{DD}	22	5	Digital Power	Output	

Table 1. Pin Descriptions(Continued)

Symbol	PLCC Pin #	VQFP Pin #	Function	Direction	Description
D _{GND}	23	6	Digital Ground		
LCS_CHK	24	7	Line Current Sense	Output	This signal is used to enable the Line Current Sense circuits in the DAA when checking for parallel phone off-hook condition prior to taking the phone line off-hook.
CID	25	8	Caller ID Relay	Output	This signal is used to turn on the Caller ID relay in the DAA.
SHTREL	26	9	Pulse Dial Shunt Relay Output	Output	SHTREL works in conjunction with pulse dial <i>make/break</i> . It offers extra-low resistance across the tip and ring. When all relays are closed, it provides 100 Ohms (Low) instead of 600 Ohms.
OH	27	10	Off-Hook Relay Output	Output	This signal is used to turn on the off-hook relay in the DAA.
D _{GND}	28	11	Digital Ground		
TXD	29	12	Transmit Data	Input	Serial transmit data to the DSP is presented on this pin.
TCLK	30	13	Transmit Data Clock	Output	This pin is a synchronous data clock used to transfer serial data via TXD to the DTE. The clock frequencies are 2400, 1200, and 300 Hz.
RXD	31	14	Receive Data	Output	The serial receive data from the DSP is presented on this pin.
RCLK	32	15	Receive Data Clock	Output	This pin is a synchronous data clock used to transfer serial data via RXD to the DTE. The clock frequencies are 2400, 1200 Hz, and 300 Hz.
V _{DD}	33	16	Digital Power		
D _{GND}	34	17	Digital Ground		
PC1	35	18	Port C	Input/Output, Serial mode only	This line can be configured as an input or output.
DTR	36	19	Data Terminal Ready	Input	This signal is asserted by the DTE when it is ready to receive data.
RTS	37	20	Request To Send	Input	This signal indicates that the DTE is ready to send data to the modem. When the modem is ready, it asserts CTS (see below).
PB2	38	21	General Purpose Output	Output	Programmable using Diplomat™.
PB3	39	22	General Purpose Output	Output	Programmable using Diplomat™.
DCD	40	23	Data Carrier Detect	Output	This signal indicates that a modem carrier signal has been detected on the line.
CTS	41	24	Clear To Send	Output	This signal indicates that the modem is ready for the DTE to send data to it.
RI	42	25	Ring Indicator	Output	When active, this signal indicates that a ring signal on the phone line is detected by the modem.
DSR	43	26	Data Set Ready	Output	This pin is the Data Set Ready pin and indicates when the modem is ready to transmit data. Refer to the &S command for details.

Table 1. Pin Descriptions(Continued)

Symbol	PLCC Pin #	VQFP Pin #	Function	Direction	Description
$\overline{S/P}$	44	27	Serial or Parallel Mode	Input	Configures the modem interface to serial or parallel mode.

MODEM STATES OF OPERATION

The Modem Controller software has several different states of operation.

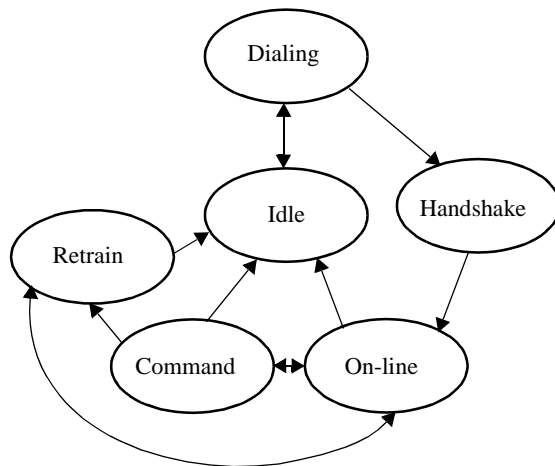

Figure 4. Modem State Diagram

Idle

When the modem is in the Idle state it is not communicating with another modem. The modem accepts AT commands from the terminal while Idle.

Dialing

When the modem dials it does the same things a person does to dial a telephone. The modem does not accept AT commands or data from the terminal while Dialing.

Handshake

When the modem handshakes it communicates with another modem to determine the data rate the two modems should use to communicate. Handshaking takes place at the

AT COMMAND SET

Command lines are typed to the modem from the terminal when the modem is in the IDLE or COMMAND state. The modem does not execute any of the commands in a command line until after the command line is ended by the end-of-line character <CR>. A command line is a string of characters starting with the A and T characters and ending

beginning of each connection between two modems. The originator and answerer of a connection perform different actions while handshaking. The modem does not accept AT commands or pass data from the terminal while Handshaking.

On-Line

After successfully completing Handshaking the modems enter the On-Line state. When a modem is in the On-Line state, data received from its terminal is sent over the telephone line the other modem. Data received from the other modem is sent to the terminal.

Command

If the terminal sends a special *escape sequence* to a modem in the On-Line state, the modem enters the Command state. During Command state the modem maintains the connection with the other modem but does not pass data between the terminal and the other modem. Instead, data received from the terminal is treated as AT commands in the same way as if the modem was in the Idle state. The modem can be returned to the On-Line state by the O command. Data received from the other modem while a modem is in Command state is discarded unless the modem can buffer it for display on the terminal when the modem re-enters the On-line state.

Retrain

During a telephone line connection, the modem tries to remain synchronized with the remote modem by adapting to changes in telephone line connection and bridging transient noises such as call waiting, analog switching and cross talk. In V.22bis and higher speed data modes, if the modem loses synchronization with the remote modem data can not be received until synchronization is restored by a process called retraining. During Retraining the modem accepts data and commands from the terminal but does not transmit data to, or receive data from, the other modem.

with a special end-of-line character, <CR>. Characters typed before the AT are ignored. Command lines contain, at most, 40 characters after the AT. The modem does not execute any of the commands in a command line that is too long.

To echo command line characters, use the E1 command.

Typing mistakes can be aborted by using a special BackSpace character, <BS>, after the initial A and T characters are entered.

A partial command line can be aborted by typing a Ctrl-X character. The modem returns an OK result code and ignores the partial AT command line.

Command lines may contain several commands one after another. The Answer (A), Dial (D), and Go on-line (O) commands usually cause the following commands in the command line to be ignored.

Command Line Execution

The characters in a command line are executed one at a time. Any unexpected characters (except control characters) stop command line execution and return an ERROR result code. Unexpected characters include numbers outside the range of values accepted by the command. All control characters in a command line except Ctrl-X (and the special characters such as <CR> and <BS>) are ignored.

The numerical argument of a command is assumed to be 0 if it is not provided. For example, the commands ATH<CR> and ATH0<CR> both hang up the telephone line.

When the modem has executed a command line, the result code of the most recent command executed is returned to the terminal.

If the value written to a modem S-register is outside the range of values accepted by the S-register, then its value is set to the nearest allowed value.

Leading 0s in numeric arguments, including S-register numbers, are ignored. For example, both set S-register S1 to 2:

```
ATS1=2
```

```
ATS01=2
```

All numeric arguments, including S-register numbers, are decimal (base 10).

AT Command Prefix

Each modem command line begins with the letters A and T. The modem uses these characters to determine the data rate and parity from the terminal.

A/ Repeat Last Command

To repeat the commands in the most recent command line, type the letters A and / instead of A and T.

<CR> End-of-Line Character

This character is typed to end a command line. The value of the <CR> character is stored in S-register S3. The default value is 13 (the ASCII carriage return character).

When the <CR> character is entered, the modem executes the commands in the command line.

Table 2. AT Command Set

North American default values are designated by **bold type**. The operation of these commands, and the default values of option commands, are configurable for operation in different countries.

Command		Function and Description
A	Answer	<p>The A command causes the modem to go off-hook and respond to an incoming call. This command is issued after the modem has returned the RING result code.</p> <p>If the modems successfully complete the answering process, each returns a CONNECT result code and enters the on-line state. If no transmit carrier signal is received from the calling modem within the time specified in S-register S7, the modem hangs up, returns the NO CARRIER result code, and enters the IDLE state.</p> <p>If the modem is in the COMMAND state or &Q2 or &Q3 is selected then the ERROR result code is returned. Any commands following the A command on the command line are ignored.</p> <p>This command is aborted if a character is received from the terminal before the answer process is completed, or when DTR drops if certain options in the &Q or &D commands have been used.</p>
B	Communication Standard Option	<p>The B command specifies special telephone line modulation standards required for the connection. The modem can be configured to use:</p> <ul style="list-style-type: none"> 1 – Bell 212A instead of ITU-T V.22 at 1200 bps 2 – Bell 103 instead of ITU-T V.21 at 300 bps 3 – ITU-T V.23 or Bell 202 in data modes with receive and transmit speeds that differ whether the caller or answerer transmits data at a higher data rate. 4 – In ITU-T V.23 data mode, Minitel line reversals. 5 – ITU-T V.23 or Bell 202T in data modes when the receive and transmit speeds are different, and with a 4-wire telephone interface instead of a 2-wire telephone interface <p>When on-line in data modes with differing receive and transmit speeds (V.23, Bell 202), the modem recognizes only the Escape Sequence (+++) and modem commands at the higher of the speeds.</p> <p>S-register S37 also contributes to the selection of the modulation standard. This register sets the telephone line data rate, and the split rate data mode (Bell 202/ Bell 202T or V.23).</p> <p>Both modems must be configured identically to prevent communication failures caused by incompatible telephone line modulation standards.</p>

Table 2. AT Command Set (Continued)

North American default values are designated by **bold type**. The operation of these commands, and the default values of option commands, are configurable for operation in different countries.

Command	Function and Description
B0	<p>This option specifies the ITU-T modulation standards for all telephone line data rates unless S-register S37 is 2. These rates include V.22 for the 1200 bps telephone line data rate, and V.21 for the 300-bps telephone line data rate.</p> <p>When the value of S-register S37 is 1 and the originating modem is transmitting at 75 bps and receiving at 1200 bps, V.23 is utilized. The answering modem transmits data at 1200 bps and receives data at 75 bps. When the value of S37 is 2 and the originating modem is transmitting at 150 bps and receiving at 1200 bps, Bell 202 is utilized. The answering modem transmits data at 1200 bps and receives data at 150 bps.</p>
B1	<p>This option specifies the Bell modulation standards for 1200 bps and 300 bps telephone line data rates, unless S-register S37 is 1. Bell 212A at 1200 bps is utilized instead of V.22. Bell 212A, V.22 is the default value for North America. Bell 103 is utilized when a 300 bps telephone line data rate is required.</p> <p>If neither the 1200 bps nor 300 bps telephone line data rate are required, then a setting of B1 is ignored and the modem operates as if B0 was set.</p>
B2	<p>When the value of S-register S37 is 1 and when the originating modem is transmitting at 1200 bps and receiving at 75 bps V.23 B1 is selected. The answering modem transmits data at 75 bps and receives data at 1200 bps.</p> <p>When the value of S register S37 is 2 and when the originating modem is transmitting at 1200 bps and receiving at 150 bps, Bell 202 is utilized. The answering modem transmits data at 150 bps and receives data at 1200 bps.</p> <p>When S-register S37 is set to any value other than 1 or 2, then a setting of B2 operates as if B0 is set.</p>
B3	<p>This option is the same as B0.</p>
B4	<p>The Minitel compatibility mode is activated by this command. It defaults to master mode (Tx75/Rx1200) if the modem is the originator.</p> <p>If S-register S37 is 1, Minitel line reversals are supported. Minitel allows a modem using V.23 and transmitting at 75 bps to simultaneously switch its transmitter to 1200 bps and receiver to 75 bps. The other V.23 Minitel modem detects the rate change and switches its transmitter to 75 bps and receiver to 1200 bps. The \R and R commands describe methods of causing a Minitel line reversal during a V.23 connection.</p> <p>When S-register S37 is set to any value other than 1, then a setting of B4 operates as if B0 was set.</p>

Table 2. AT Command Set (Continued)

North American default values are designated by **bold type**. The operation of these commands, and the default values of option commands, are configurable for operation in different countries.

Command	Function and Description
	<p>B5 When S-register S37 is 1 (V.23) or 2 (Bell 202T), the modem assumes that a 4-wire telephone connection exists. Both the transmitter and receiver use the 1200 bps telephone line data rate. This mode does not operate properly unless a 4-wire telephone connection exists.</p> <p>When S-register S37 is set to any value other than 1 or 2, the B5 option operates as if B0 is set.</p>
<p>&C Data Carrier Detect Options</p>	<p>This command determines how the modem’s DCD signal relates to the carrier signal (RLSD) from the other modem. This option takes effect only at the beginning of a telephone line connection. If &C is issued from the COMMAND state, no immediate effect results.</p> <hr/> <p>&C0 During asynchronous operation (&Q0 in effect), DCD is on at all times. During synchronous operation (&Q1, &Q2 or &Q3), DCD reflects the state of the carrier signal from the other modem using S-registers S9 and S10. This command is the default value in North America.</p> <hr/> <p>&C1 This command reflects the state of the carrier signal from the other modem using S-registers S9 and S10.</p>
<p>#CID= Caller ID Options</p>	<p>This command controls how the modem displays North American caller identification information. If Caller ID has been disabled in the country configuration, the modem responds with an ERROR result code to a #CID= command.</p> <p>Caller ID information is displayed only when it is provided by the telephone company, and only when the terminal data rate is 2400 bps or higher. Lower data rates are too slow to display Caller ID information.</p> <hr/> <p>#CID=0 This command does not display Caller ID information. This option is the default value.</p> <hr/> <p>#CID=1 This command returns the information as formatted data.</p> <hr/> <p>#CID=2 This command returns the information as unformatted data.</p> <hr/> <p>#CID=? This command returns the current setting of the #CID=command.</p>

Table 2. AT Command Set (Continued)

North American default values are designated by **bold type**. The operation of these commands, and the default values of option commands, are configurable for operation in different countries.

Command		Function and Description																									
D	Dial	<p>The D command initiates a telephone call using the digits and dial modifiers in the dial string following the command. Any commands following the dial string on a command line are ignored, unless a semicolon is the last character in the dial string. If the modem was already off-hook when the Dial command is issued, the modem dials immediately without trying to detect a dial tone. Characters other than digits and dial modifiers in a dial string are ignored; however, ignored characters are counted in the command line buffer.</p> <p>If line-current sensing is enabled and line current is detected before the modem is taken off-hook when the modem must dial, a NO CARRIER result code is displayed and the modem enters the IDLE state.</p> <p>If the modem is not required to perform a dial function (for example, ATD with no dial string), the modem assumes the call was manually established and attempts to make a connection.</p> <p>The X1 command may be used to disable the modem's need to detect dial tone or busy tone before handshaking.</p> <p>The D command is not valid when the modem is in the on-line state or when &Q2 or &Q3 is in effect.</p> <p>See "Dial Modifiers" on page 20 for more information.</p>																									
&D	Data Terminal Ready Options	<p>The &D command determines the modem's response to the DTR signal from the terminal.</p> <p>S-register S25 debounces changes in DTR. During connection, the modem does not act on changes in DTR until the change is present for the length of time specified by the setting in S23.</p> <p>The response to changes in DTR also depend on the value of &Q (See "&Q" on page 16 for further details).</p> <p>When DTR is OFF for all possible combinations of the &D and &Q commands, the results are as described below. The default value is &D0 in North America.</p>																									
		<table border="1"> <thead> <tr> <th></th> <th>&D0</th> <th>&D1</th> <th>&D2</th> <th>&D3</th> </tr> </thead> <tbody> <tr> <td>&Q0</td> <td>None</td> <td>B</td> <td>C</td> <td>D</td> </tr> <tr> <td>&Q1</td> <td>C</td> <td>B</td> <td>C</td> <td>D</td> </tr> <tr> <td>&Q2</td> <td>C</td> <td>C</td> <td>C</td> <td>D</td> </tr> <tr> <td>&Q3</td> <td>C</td> <td>C</td> <td>C</td> <td>D</td> </tr> </tbody> </table>		&D0	&D1	&D2	&D3	&Q0	None	B	C	D	&Q1	C	B	C	D	&Q2	C	C	C	D	&Q3	C	C	C	D
	&D0	&D1	&D2	&D3																							
&Q0	None	B	C	D																							
&Q1	C	B	C	D																							
&Q2	C	C	C	D																							
&Q3	C	C	C	D																							
		<p>A The modem hangs up the telephone line and issues an OK result code.</p>																									
		<p>B If in the ON-LINE state, the modem goes into the COMMAND state, and issues an OK result code.</p>																									
		<p>C The modem hangs up the telephone line and issues an OK result code. Auto-Answer is disabled as long as DTR stays OFF.</p>																									
		<p>D The modem resets.</p>																									

Table 2. AT Command Set (Continued)

North American default values are designated by bold type. The operation of these commands, and the default values of option commands, are configurable for operation in different countries.

Command		Function and Description
E	Command Mode Character Echo	This command enables or disables character echoing sent from the terminal when the modem is accepting AT commands.
		E0 Does not echo characters sent from the terminal.
		E1 Echoes characters sent from the terminal. This value is the default value in North America.
%E	Automatic Retrain Options	The %E command enables or disables retraining with the other modem during a telephone line connection (during operation in data modes supporting retrain). The modem always responds to a retrain operation initiated by the remote modem. The modem can be forced to initiate a retrain by the ON-LINE (O1) command.
		%E0 Retrain is not initiated automatically.
		%E1 Retraining is initiated if the data pump indicates retraining is required. This value is the default value.
&F	Recall Factory Profile	&F changes these AT command options to their default values. The default values may be changed for use by country.
		S0=0 S1=0 S2=43 S3=13 S4=10 S5=8
		S6=2 S7=30 S8=2 S9=6 S10=14 S11=95
		S12=50 S17=10 S25=5 S28=0 S29=25 S37=0
		Commands
		B1 E1 M1 P Q0 V1 X4 &C0 &D0 &G0 &P0 &K3 &Q0 &S0
		%E1 \N1 \Q3 \R0
&G	Guard Tone Options	The &G command selects the guard tone to be transmitted when the modem is transmitting the High band (for example, ANSWER HANDSHAKE and ANSWER mode).
		&G0 No guard tone. This value is the default value in North America.
		&G1 550 Hz guard tone (V.22, V.22bis and Bell 212A only)
		&G2 1800 Hz guard tone (V.22, V.22bis and Bell 212A only)
H	Hook	H0 Off-hook.
		H1 Off-hook without answering a telephone call. This option may be disabled in countries prohibiting its use.

Table 2. AT Command Set (Continued)

North American default values are designated by **bold type**. The operation of these commands, and the default values of option commands, are configurable for operation in different countries.

Command		Function and Description		
&HT	PTT Test	The &HT command enables the modem to transmit tones for PTT testing. The test tone is generated until a character is typed on the modem's terminal. If this command is issued when the command is disabled by a country configuration, the modem returns an ERROR result.		
		&HT0 – &HT9 DTMF tone for digit <i>n</i> where the command is &HT <i>n</i>		
		&HT10 DTMF tone "*"		
		&HT11 DTMF tone "#"		
		&HT12 DTMF tone "A"		
		&HT13 DTMF tone "B"		
		&HT14 DTMF tone "C"		
		&HT15 DTMF tone "D"		
		&HT16 V.21 channel 1 mark		
		&HT17 V.21 channel 2 marks		
		&HT18 V.23 1200bps marks		
		&HT19 V.23 75bps marks		
		&HT20 V.21 channel 1 spaces		
		&HT21 V.21 channel 2 spaces		
		&HT22 V.23 1200bps spaces		
		&HT23 V.23 75bps spaces		
		&HT24 V.22 originate mode		
		&HT25 V.22 answer mode		
		&HT26 V.22bis originate mode		
		&HT27 V.22bis answer mode		
		&HT28 V.25 calling tone		
		&HT29 550-Hz guard tone		
		&HT30 1800-Hz guard tone		
		&HT31 Silence		
		&HT32 Detect 2100-Hz answer tone		
		&HT33 Detect all supported answer tones simultaneously		
		&HT34 Detect dial tone		
		&HT35 Detect call progress tones		
		I	Identification	The I command queries the modem for information that can be used to determine the modem's compatibility with other software and to ensure the modem is operating properly.
				I0 Product Code. The modem reports its product code to the terminal. The modem produces information text dependent upon its features and capabilities.
				I1 ROM Checksum. The modem reports the value of its ROM checksum. The decimal number displayed is the 8-bit sum (from 0 to 255) of all the bytes in ROM.
				I2 ROM Checksum. The modem checks its ROM and reports a result code of OK or ERROR.
				I3 Software Versions. The modem reports its software versions and release date.
				I4 Modem Identification. The modem reports a configurable identification message to the terminal.

Table 2. AT Command Set (Continued)

North American default values are designated by bold type. The operation of these commands, and the default values of option commands, are configurable for operation in different countries.

Command		Function and Description
&K	Flow Control	This command provides compatibility with the &K functions in the Rockwell AT command set.
		&K0 This option disables flow control.
		&K3 This option enables RTS/CTS flow control. Same as \Q3.
		&K4 This option enables XON/XOFF Flow control. Same as \Q1.
M	Speaker ON/OFF Options	M0 The speaker is always OFF.
		M1 The speaker is ON until the carrier is detected. This value is the default value in North America.
		M2 The speaker is always ON (in this case, the speaker stays ON after the carrier is detected).
		M3 The speaker is off as digits are dialed, but on during ringback and the until carrier signal is detected.
\N	Asynchronous Terminal Data Options	The \N command determines the path of asynchronous format data through the modem to the terminal. The data path is set at the start of a telephone line connection. The Communications Mode Options (&Q) determines whether terminal data is in asynchronous or synchronous format.
		\N0 This command is NORMAL (or buffered) operation. This mode enables data rate matching between the telephone line and terminal, and flow control between the modem and the terminal. In all data modes (V.22bis, V.22, Bell 212A, V.23, Bell 202, Bell 202T, V.21 and Bell 103), data is buffered through the modem controller before being modulated to and from the telephone line.
		\N1 This command is the DIRECT operation. This mode does not enable data rate matching, or flow control between the modem and the terminal. After the CONNECT message is displayed, the terminal adjusts the data rate to match the telephone line rate. In V.23, V.21, Bell 202, Bell 202T, and Bell 103 data modes, data from the terminal is directly modulated to and from the telephone line. In V.22bis, V.22 and Bell 212A data modes, data from the terminal is converted to SYNCHRONOUS format using ITU V.14 to adjust for small (up to 2.5%) timing discrepancies in the data rate without the use of flow control. This value is the default value.
O	Return to ON-LINE Mode	The O command returns the modem to the ON-LINE mode. It frequently follows the escape character sequence (+++) to resume communication with the remote modem. If handshaking is started, the modem uses ORIGINATE or ANSWER mode handshaking.
		O0 This option returns the modem to the ON-LINE state from the COMMAND state during a telephone line connection. The modem starts handshaking if there is no telephone line connection and the modem is off-hook.
		O1 This option returns the modem to the ON-LINE state and retrains its data pump during a telephone line connection. The modem starts handshaking if no telephone line connection exists and the modem is off-hook.
P	Pulse Dialing	Selects the PULSE method of dialing. Pulse is the default dialing method in North America.

Table 2. AT Command Set (Continued)

North American default values are designated by **bold type**. The operation of these commands, and the default values of option commands, are configurable for operation in different countries.

Command		Function and Description
&P	Pulse Dial Make/Break Ratios	The &P command sets the cadence of the pulse dial. The country configuration may disable this command, forcing particular pulse dialing parameters. When country restrictions are in effect and this command is issued, the modem returns an ERROR result.
		&P0 39%/61% make/break ratio and 10 pulses per second when pulse dialing. This value is the default value.
		&P1 33%/67% make/break ratio and 10 pulses per second when pulse dialing.
		&P2 39%/61% make/break ratio and 20 pulses per second when pulse dialing.
		&P3 33%/67% make/break ratio and 20 pulses per second when pulse dialing.
Q	Result Code Display Options	This command enables or disables display of result codes.
		Q0 For this option, result codes are displayed. This value is the default value for North America.
		Q1 Result codes are not displayed.
&Q	Communications Mode Options	The &Q command selects the terminal communication mode: asynchronous or synchronous. Async terminal data..... Synchronous terminal data is transmitted directly between the terminal and data pump using the data pump clock signals.
		&Q0 Asynchronous mode. This value is the default value for North America. The \N command controls asynchronous terminal data options.
		&Q1 Synchronous mode. This option disconnects the modem from the line if DTR goes from ON to OFF for longer than the time in S-register S25 after the CONNECT result code has been sent to the terminal.
		&Q2 Synchronous mode. This option takes the telephone line off-hook and either answers or dials when DTR goes from OFF to ON. If S-register S0 has been set to answer the telephone line (S0 > 0) and more than the specified number of ring signals are received (see S-Register S1), then the modem answers, otherwise the modem dials the stored telephone number (see &Z). When DTR goes from ON to OFF for longer than the time in S-register S25, the modem disconnects from the line.
		&Q3 Synchronous mode. This option takes the telephone line off-hook and handshakes as either an answerer or an originator when DTR goes from OFF to ON. If S-Register S0 has been set to answer the telephone line (S0 > 0) and the number of signals received is greater than the value of S0(see S-Register S1) then the modem answers. Otherwise, the modem originates. Hangs up when DTR goes from ON to OFF for longer in time than the value of S-register S25.

Table 2. AT Command Set (Continued)

North American default values are designated by bold type. The operation of these commands, and the default values of option commands, are configurable for operation in different countries.

Command		Function and Description
\Q	Flow Control	<p>The \Q command specifies flow control between the modem and the terminal when \N0 is selected.</p> <p>Flow control prevents data from being lost by preventing the terminal from sending data to the modem too quickly. The modem issues flow-control characters to the terminal to inform it to stop sending data. When it is able to receive more data by informing the terminal to resume sending data.</p> <p>Similarly, the terminal can use flow control to prevent data loss caused by the modem sending data too quickly to the terminal. Flow control does not work unless both the terminal and the modem are configured to use the same type of flow control.</p>
\Q0	This option disables flow control.	
\Q1	This option enables XON/XOFF flow control. In this mode, either the modem or terminal may send an XOFF character to stop the other device from sending data. An XON character is sent to resume the transmission of data.	
\Q2	This option enables CTS flow control. The modem turns its CTS signal OFF to stop data transfer. The modem turns its CTS signal ON to permit data transfer.	
\Q3	This option enables RTS/CTS flow control. In this mode, the modem uses its CTS signal as described in \Q2. The terminal turns its RTS signal OFF to stop data transfer. The modem turns its RTS signal ON to permit data transfer. This value is the default value.	
\Q4	This option enables unidirectional Data communication Equipment (DCE)-to-Data Terminal Equipment (DTE) XON/XOFF flow control. In this mode, the modem sends an XOFF character to instruct the terminal to stop sending data. The modem sends an XON character to instruct the terminal to resume sending data. The modem treats XON and XOFF characters sent from the terminal to the modem as data characters.	
R	Minitel Line Reversal	<p>If the modem is in the IDLE state, the R command configures the modem to enter STATIC REVERSE mode when a Minitel connection is made. If the modem has a connection and is in Minitel MASTER mode then issuing the R command performs a direct turnaround. If the reversal is successful then the modem returns OK. If the reversal is unsuccessful, the modem returns OK. Otherwise, it returns NO CARRIER. If the modem is not in MASTER mode, ERROR is returned.</p> <p>When B4 and S37 are 1 and the terminal is transmitting at 75 bps during Minitel V.23 operation, the transmit and receive rates change to 1200 bps and 75 bps respectively. If the remote modem supports and is configured for Minitel operation with line reversals, it automatically detects the rate switch and changes its own transmit and receive data rates. See “Minitel Line Reversal” on page 25 for details.</p> <p>Note: R may be followed the O command in the command line to return on-line immediately.</p>

Table 2. AT Command Set (Continued)

North American default values are designated by **bold type**. The operation of these commands, and the default values of option commands, are configurable for operation in different countries.

Command	Function and Description
\R	<p>Minitel line reversal using RTS Options</p> <p>During V.23 Minitel connections, B4 and S37 are 1. When the modem is transmitting at 75 bps, it can be configured to perform a Minitel line reversal when RTS changes from ON to OFF.</p> <p>To perform a Minitel line reversal, the modem transmitting at 75 bps changes its transfer rate to 1200 bps (transmit) and 75 bps (receive). If the remote modem supports and is configured for Minitel operation with line reversals, it automatically detects the rate switch and changes its own transmit and receive data rates. See the section on See "Minitel Line Reversal" on page 25 for details.</p> <p>\R0 This option does not execute a Minitel line reversal when RTS changes from ON to OFF. This value is the default value.</p> <p>\R1 This option performs a Minitel line reversal when RTS changes from ON to OFF.</p>
Sn	<p>Sets the current S-register to n</p> <p>The Sn command sets the current S-register to the value <i>n</i> selected by the user. For example, ATS7 sets the current S-register to S7. Default value is 0. Sn addresses a particular S-register number so future commands like ? and = reads or writes the S-register. Modem reset and the &F command select S0 as the default S-register.</p>
&S	<p>Data Set Ready</p> <p>The &S command controls Data Set Ready. If &Q1, &Q2 or &Q3 (SYNCHRONOUS mode) is selected, the modem's DSR signal operates as if &S1 is set. If &Q0 (ASYNCHRONOUS mode) has been selected:</p> <p>&S0 This option forces DSR always ON. This value is the default value in North America.</p> <p>&S1 This option causes the modem's DSR signal to be ON at the start of handshaking and OFF when the modem is retraining or in the IDLE state.</p>
,	<p>Pause</p> <p>Comma (,) makes the modem pause for a length of time in S-register S8 before processing the next character in the command line.</p>
?	<p>Read an S-Register</p> <p>The ? command displays the value of the last S-register named in the Sn command.</p>
=x	<p>Write an S-register</p> <p>The =x command writes the value <i>x</i> to the last S-register named in the Sn command. The range of valid values for <i>x</i> depends upon the S-register being written. The value 0 is assumed if no value is provided for <i>x</i>.</p>
T	<p>Tone Dialing</p> <p>Selects the tone method of dialing.</p>

Table 2. AT Command Set (Continued)

North American default values are designated by bold type. The operation of these commands, and the default values of option commands, are configurable for operation in different countries.

Command		Function and Description
V	Result Code Format	<p>The V command changes the format in which result codes are displayed.</p> <p>V0 All result codes are displayed as numbers.</p> <p>V1 All result codes are displayed as words (verbose form). This value is the default value for North America.</p>
X	Call Progress	<p>The X command controls detection of a busy signal or dial tone when the modem is dialing. The X command also limits the result codes the modem may return when dialing. The operation of the X command is configurable for operation in different countries.</p> <p>X0 Neither a busy signal nor a dial tone is detected. When a telephone line connection is made, the result code does not indicate the telephone line data rate.</p> <p>X1 Neither a busy signal nor a dial tone is detected. When a telephone line connection is made, the result code indicates the telephone line data rate.</p> <p>X2 A busy signal is not detected; however, a dial tone is detected. When a telephone line connection is made, the result code indicates the telephone line data rate.</p> <p>X3 Busy signal is detected; however, a dial tone is not detected. When a telephone line connection is made, the result code indicates the telephone line data rate.</p> <p>X4 Both a busy signal and a dial tone are detected. When a telephone line connection is made, the result code indicates the telephone line data rate. This value is the default value in North America.</p> <p>The @ and W dial modifiers are not affected by the X command. The @ dial modifier may return the result codes 8 (NO ANSWER) or 7 (BUSY) each time it appears in the dial string. The W dial modifier may return the result codes 6 (NO DIALTONE) or 7 (BUSY) each time it appears in the dial string.</p>
&Z0=x	Store Telephone Number	<p>The &Z0=x command saves a dialing string in the modem's nonvolatile memory (EEPROM). The value of X may be up to 36 characters long and may contain any dialing digits or modifiers, except the S=n modifier. Characters that are neither dialing digits or dial modifiers are ignored and not stored. If the modem does not feature nonvolatile memory, an ERROR result code is returned. The command may be issued in one of three different ways:</p> <p>&Z<dial string> &Z=<dial string> &Z0=<dial string></p>

DIAL MODIFIERS

Dial modifiers perform special functions within a dial command.

Example: ATDT9W1552368!@#71234;<CR>

In this example, the modem is instructed to use tone dialing

- (T), to access a number outside a PBX

- (9), to wait for dial tone
- (w), to dial the number 1552368
- To do a hook-flash (for example, timed break recall)
- To wait for quiet answer
- To issue the PBX transfer code #7 before dialing extension number 1234.

After these instructions are executed, the modem returns to the COMMAND state before initiating the handshake.

Table 3. Dial Modifiers

Modifier	Function
0-9 A B C D # *	Dialing digits and characters. The digits and characters 0-9 A B C D # * specify the numbers the modem dials. The characters A B C D # * apply only to tone dialing. The characters are ignored for pulse dialing. The characters A, B, C, and D may be disabled in countries prohibiting their use.
P	Pulse dialing. P selects the PULSE method of dialing. This command may be issued within a dial command or as a separate command. The default method of dialing is PULSE.
R	Originate a call in ANSWER mode. R causes the modem to handshake in ANSWER mode so it can originate a call to an originate-only modem.
S=n	Dial a stored telephone number. The equals command S=0 instructs the modem to dial a stored telephone number if the modem has nonvolatile memory (EEPROM) to store country parameters. Stored numbers may contain any dial digits or modifiers. Telephone numbers may be stored using the &Z command. If the modem does not feature nonvolatile memory (EEPROM) and the S command is issued, an ERROR result code is returned.
T	Tone dialing. T selects the TONE method of dialing. T can be issued within a DIAL command or as a separate command. The default method of dialing is PULSE.
W	Wait for dial tone. W causes the modem to wait for a dial tone before proceeding. If no dial tone is detected, the modem hangs up the telephone line and returns the NO DIALTONE result code.
,	Delay processing of next character. A comma (,) causes the modem to pause for the length of time in S-register S8 before processing the next character in a dial string.
@	Wait for quiet answer. The @ modifier causes the modem to listen for silence before continuing. The modem waits up to the length of specified time in S-register S7. If enough (configurable by country) silence is not detected within the time period specified in S-register S7, the modem hangs up and returns the NO ANSWER result code. If enough silence is detected, the modem continues processing the other characters in the dial string.
!	Timed break recall (Hookflash). An exclamation point (!) causes the modem to hang up the telephone line for the length of time specified in S-register S29, then take the telephone line off-hook again. This modifier is frequently used to access a PBX's call transfer function.
;	Return to COMMAND state after dialing. A semicolon (;) instructs the modem to return to COMMAND state after dialing without breaking the telephone line connection and without handshaking with the other modem. The semicolon may only be used when calling a voice mail system that permits tones to transmit numbers when a connection is established.

SETTING THE HIGHEST LINE RATE

The connect rate can be selected by S-register S37. The following connect rates are supported.

Table 4. S37 Register Connect Rates

S37 Value	Carrier	Data Rate
0		The Data Rate of the Last AT Command
1	V.23	1200/75 bps. Refer to the Communication Standard Options (B) command for a description. When ONLINE, the modem recognizes the Escape Sequence (+++) and modem commands only at 1200 bps.
2	Bell 202, Bell 202T	1200/150 bps. Refer to the Communication Standard Options (B) command for a description. When ONLINE, the modem recognizes the Escape Sequence (+++) and modem commands only at 1200 bps.
3	V.21, Bell 103	300 bps. Refer to the Communication Standard Options (B) command for a description.
4		Reserved
5	V.22, Bell 212A	1200 bps. Refer to the Communication Standard Options (B) command for a description.
6	V.22bis	2400 bps

RESULT CODES

A result code is a line of text or a number that the modem sends to the terminal to indicate the result of a command execution. Some connect result codes indicate the telephone

line data rate. The following table provides a list of the available result codes.

Table 5. Result Codes

Number	Word	Result Code Description
0	OK	A command line is executed successfully without errors.
1	CONNECT	The modem is in the ON-LINE state, ready to transfer data.
2	RING	The modem has detected a ring signal on the telephone line. The country configuration may disable the modem's ability to detect a telephone line ring signal.
3	NO CARRIER	Either no carrier signal is detected when answering/placing a telephone call or the carrier is lost during a call. The modem also returns this result code when the telephone line connection is broken for any reason.
4	ERROR	An invalid command is issued, or there an error exists in the command line.
5	CONNECT 1200	The modem is in the ON-LINE state, ready to transfer data. The telephone line data rate is 1200 bps.

Table 5. Result Codes

Number	Word	Result Code Description
6	NO DIALTONE	No dial tone is detected when the modem takes the telephone line off-hook.
7	BUSY	The modem detects a busy signal on the telephone line.
8	NO ANSWER	A too short period of silence is detected in response to the @ dial modifier.
10	CONNECT 2400	The modem is in the ON-LINE state, ready to transfer data. The telephone line data rate is 2400 bps.
16	CONNECT 1200TX/75RX	The modem is in the ON-LINE state, ready to transfer data. This modem transmits at 1200 bps and receives at 75 bps.
17	CONNECT 75TX/1200RX	The modem is in the ON-LINE state, ready to transfer data. This modem transmits at 75 bps and receives at 1200 bps.
18	CONNECT 1200TX/150RX	The modem is in the ON-LINE state, ready to transfer data. This modem transmits at 1200 bps and receives at 150 bps.
19	CONNECT 150TX/1200RX	The modem is in the ON-LINE state, ready to transfer data. This modem transmits at 150 bps and receives at 1200 bps.
20	BLACKLISTED	The modem does not allow any number to be dialed until the modem is reset.
21	DELAYED	The modem does not allow any number to be dialed now, until a specified time period elapses.

MODEM S-REGISTERS

Modem S-registers contain the values of special purpose ASCII characters, timing parameters and other modem parameters. The value of an S-register is modified by the AT S command. Each S-register has three values that may be configured for specified countries: a default value, an

upper limit, and a lower limit. The values described in this manual are for North America.

Table 6. Modem S-Registers

Register	Range	Default	Units	Description
S0	0-255	0	Rings	Sets number of rings before auto-answer. The modem automatically answers the telephone after it rings the number of times specified in register S0. If S-register S0 is 0 the modem does not automatically answer the telephone. Any value from 0 to 255 is valid. The country configuration may disable the modem's ability to detect a telephone line ring signal. In this case, the modem never automatically answers the telephone regardless of the S0 setting. The default value is 0 (auto-answer disabled)
S1	0-255	0	Rings	Returns the number of times the phone rings. When the modem is in the IDLE state and set to automatically answer the telephone (S-register S0 > 0), the modem records the number of times the phone rings in S-register S1. The value of S1 reverts to 0 if no ring occurs for several seconds.
S2	0-255	43	ASCII	Sets escape sequence character. S-register S2 is the value of the escape sequence character. Setting S2 to a value greater than 127 disables the character escape sequence, preventing the modem from returning to Command state when in the on-line state. The ASCII default value is +.
S3	0-127	13	ASCII	Sets the end-of-line character. S-register S3 is the value of the end of line character. S3 is used at the end of command lines and result codes.
S4	0-127	10	ASCII	Sets the line feed character. S-register S4 is the value of the character for line feed.
S5	0-127	8	ASCII	Sets the backspace character. S-register S5 is the value of the character for backspace. This character moves the cursor left on a command line, deleting the previous character.
S6	2-255	2	Seconds	Delay to wait before performing a blind dial. S-register S6 is the modem's delay after going off-hook before blind dialing (that is, dialing without waiting for a dial tone). The delay lets the central telephone office detect the modem has gone off-hook and put a dial tone on the line. This delay only applies to the first dial tone. S-register S6 is used only if X0, X1 or X3 has been selected. The W dial modifier in the DIAL command applies only to detection of dial tone at a later time and is independent of S6.
S7	1-255	30	Seconds	Delay to wait for carrier after dialing. S-register S7 is the maximum amount of time the modem waits for a dial tone (see Table 3, "Dial Modifiers," on page 20, W dial modifier), waiting for silence (@ dial modifier), dialing or handshaking. When answering, the modem may spend time handshaking up to the amount specified in S7 (taking the telephone line off-hook until entering DATA mode). When calling, the modem may spend up to to the amount specified in S7,(from taking the telephone line off-hook until beginning handshaking). Then the modem may spend additional time handshaking, up to the amount specified in S7, with the other modem until entering DATA mode. The modem hangs up and returns the NO DIALTONE, NO ANSWER or NO CARRIER result codes if a length of time longer than the amount specified in S7 is required for these operations.
S8	0-255	2	Seconds	Delay to wait when a comma dial modifier is processed. S-register S8 is the duration of the delay when the comma (,) command or dial modifier is processed.

Table 6. Modem S-Registers (Continued)

Register	Range	Default	Units	Description
S9	1–255	6	1/10th sec	Time carrier must be present before being recognized. S-register S9 is the number of tenths of a second a carrier signal must be present before the modem recognizes it
S10	1–255	14	1/10th sec	Delay between lost carrier and hang up. S-register S10 is the time between loss of the carrier signal from the other modem and hang up by this modem. The carrier signal may be lost for periods up to S10 minus S9 without causing the modem to hang up. Setting S-register S10 to 255 causes the modem to never hang up the telephone line because of loss of carrier. The modem only recognizes a carrier signal after the time specified in S-register S9. S-register S10 must always be greater than S-register S9 so a carrier signal can be recognized before the telephone line goes off-hook.
S11	50–255	95	msec	Multi-frequency tone duration. S-register S11 is the duration of a DTMF tone. The country configuration may also specify that S11 is the time between DTMF tones.
S12	0–255	50	1/50th sec	Escape prompt delay time. Register S12 is the prompt delay time for escape sequences from the on-line state to the COMMAND state.
S13	Reserved		Reserved	Reserved
S14	Reserved		Reserved	Reserved
S15	Reserved		Reserved	Reserved
S16	Reserved		Reserved	Reserved
S17	6 to 43	10	–dBm	Sets transmit level. The actual transmit power used is adjustable by the country configuration to accommodate differences in transformers and other components in the telephone line interface.
S18	Reserved		Reserved	Reserved
S19	Reserved		Reserved	Reserved
S20	Reserved		Reserved	Reserved
S21	Reserved		Reserved	Reserved
S22	Reserved		Reserved	Reserved
S23	Reserved		Reserved	Reserved
S24	Reserved		Reserved	Reserved
S25	0–255	5	seconds or 1/100 sec.	DTR detection. During synchronous operation with the &Q1 command in effect, S-register S25 is the number of seconds after a telephone line connection is made before the modem examines DTR. This action allows sufficient time to disconnect the modem from an asynchronous terminal and attach it to a synchronous terminal. In the ONLINE or COMMAND state during any mode of operation, changes in DTR for less than S25 hundredths of a second are ignored.
S26	Reserved		Reserved	Reserved
S27	Reserved		Reserved	Reserved
S28	0–255	0	minutes	Terminal inactivity time-out. Hangs up the modem after the number of minutes specified in S28 if no characters are received from the modem's terminal.
S29	0–255	25	1/50th sec	Hook flash on-hook time. The amount of time in 20 millisecond units the modem leaves the telephone on-hook while performing a hook-flash according to the ! dial string modifier.

Table 6. Modem S-Registers (Continued)

Register	Range	Default	Units	Description
S37	0–6	0	code	<p>Sets the highest line rate. This register determines the highest telephone line data rate the modem uses when connecting with a remote modem. If S37 is set to a data rate higher than the modem supports it attempts to connect at its highest data rate.</p> <p>The Communication Standard Options command (B) controls which modulation standards are allowed for telephone line data rates that feature more than one choice.</p> <p>S37 refers to the telephone line data rate. The modems may communicate with their terminals at different data rates.</p> <p>In case of conflict between the B option and S37, S37 takes precedence. Configure both modems identically to prevent communication failures caused by incompatible telephone line modulation standards.</p> <p>See “Setting the Highest Line Rate” on page 21 for different Communication Standards.</p>

MINITEL LINE REVERSAL

The modem contains code that supports the Minitel Line Reversal method, as specified in the STUM documentation (Minitel specification). Table 7 describes the terminology and definitions used in this section.

Table 7. Minitel Terminology and Definitions

STATIC REVERSE mode	The ability of the modem to dial and connect in REVERSE mode (Rx@75 bps, Tx @ 1200 bps).
DYNAMIC REVERSE mode	The ability of the modem to enter REVERSE mode one connected (switching from one mode to the next).
MASTER mode	NORMAL mode (Tx75/Rx1200 from the originator side)
SLAVE mode	REVERSE mode (Tx1200/Rx75 from the originator side)
Direct turnaround	Entering REVERSE mode
Reverse turnaround	Entering NORMAL mode

General Description of the Turnaround Principle

Only the modem which is in MASTER mode can physically initiate a turnaround by changing its carrier from 390Hz to 1300Hz. When this change occurs the remote modem, which is in SLAVE mode, detects the changing carrier and also reverses.

The Minitel STUM specifies character sequences that are exchanged by the Data Terminal Equipment and the PAVI (Videotex server) to determine if the PAVI can reverse (before the first turnaround). Some character sequences are also sent through the Minitel modem to request a Reverse turnaround from the PAVI, and then acknowledge the turnaround. The modem ignores these sequences.

DYNAMIC REVERSE Mode

Direct Turnaround

To perform a direct turnaround, the user enters into ONLINE COMMAND mode by sending the +++ escape command or by making an active/inactive DTR transition (if AT and DI has been previously executed). The user then sends the ATRO command (an R command followed by an O command). As the modem supports the TIES escape sequence the following command may be sent.

```
+++ATRO<CR>
```

The modem then goes off-line, executes the R command, and returns on-line.

Alternatively, the user can select the \R1 command option and use the RTS hardware signal to initiate a line reversal. When RTS changes from active (logic 0 or 0 volts) to inactive (logic 1 or +5 volts), the line turnaround executes.

This method is the fastest method of executing the line turnaround.

At execution of the `R` command, the `Carrier Detect` signal (`CD`) goes inactive, the modem reverses (its carrier changes from 390 Hz to 1300 Hz), and waits for a 390Hz carrier for 440ms.

- If the modem detects more than 40 ms of a 390 Hz carrier within 440 ms, it sends the `CONNECT 1200/75` result code to the Host. `CD` goes active.
- If the modem does not detect more than 40 ms of a 390 Hz carrier within 440 ms, it hangs up and sends the `NO CARRIER` code to the Host.

Reverse Turnaround

The modem performs a Reverse turnaround when it detects a carrier drop longer than 20 ms. The `Carrier Detect` (`CD`) signal goes inactive and the modem reverses its carrier (from 1300 Hz to 390 Hz) and waits for a 1300 Hz carrier for 220 ms.

- If the modem detects more than 40 ms of a 1300 Hz carrier within 220 ms, it sends the `CONNECT 75/1200` code to the Host. `CD` goes active.
- If the modem does not detect more than 40 ms of a 1300 Hz carrier within 220 ms, it reverses again and waits for a 390 Hz carrier for 220 ms.
 - If the modem detects more than 40 ms of a 390 Hz carrier within 220 ms, it sends the `CONNECT 1200/75` code to the Host. `CD` goes active (there was a short carrier dropout).
 - If the modem does not detect more than 40 ms of a 390 Hz carrier within 220 ms, it hangs up and sends the `NO CARRIER` code to the Host.

If the modem is in `REVERSE` mode and receives the `R` command, it sends the `ERROR` code to the Host.

STATIC REVERSE Mode

If the command `ATR` has been executed, the following `ATD` command forces the modem to try to connect in `REVERSE` mode.

ESCAPE SEQUENCES

An escape sequence is one or more particular characters sent from the terminal to the modem during the on-line state. This sequence is activated to switch the modem to the command state so modem commands may be entered during a telephone line connection. The Escape Sequence characters are typically sent to the other modem as data.

An escape sequence must not occur accidentally during an exchange of data between two modems. Unfortunately, it is impossible to guarantee that any escape sequence never occurs accidentally, because there are no restrictions on the data or timing between characters sent between two modems during the ONLINE state.

The only method of switching from the ONLINE state to the COMMAND state that never occurs accidentally during an exchange of data is the Data Terminal Ready signal (the &D1 command). The terminal has complete control of this signal, and it is not part of the data exchanged between the modems.

TIES Escape Sequence

TIES is a sequence of three escape characters (+ characters by default). When these characters are recognized, the modem enters the Command state without sending a confirming result code to the terminal. The modem then starts a prompt delay timer. During the prompt delay, the following situations may occur:

- If one of the recognized AT commands is received before the timer expires, the timer is stopped, the command is executed, and its result code is sent to the terminal.
- If any other data is received while the timer is running, the timer is stopped, the modem returns to the On-line state, and the received data is sent to the other modem.
- If the timer expires, a confirming result code is sent to the terminal, indicating the modem is in the COMMAND state.

The escape character and prompt delay timer can be changed by writing new values to S-registers S2 and S12.

CARRIER DETECTION

After handshaking, the modem determines if a telephone line connection exists by detecting the carrier signal from the other modem. If the carrier is not detected for a specified period of time, the modem assumes the telephone line connection with the other modem has been broken. The

modem uses S-register S9 to determine how long a carrier must be present before it is detected. The modem uses S-register S10 to determine how long a carrier may not be detected before the telephone line is disconnected.

BLACKLISTING MANAGEMENT

Blacklisting applies separately to each number dialed, and indicates the call blocking capability for specific phone numbers. To minimize RAM, calls are treated as if they are all to the same number.

BLACKLISTED result code (if no calls may be made later).

The first connection attempt after modem reset or a successful connection is always allowed. If a connection attempt is not successful, then each following connection attempt is checked as follows:

The following Blacklisting parameters can be controlled through Diplomat™:

- a. If voice answer was detected too many times the attempt is not allowed, the modem returns a BLACKLISTED result code.
- b. If the attempt occurred too quickly (within the inter-call timing period) then the attempt is not allowed, and the modem returns a DELAYED result code.
- c. If there is a blacklisting period limiting the number of attempts that may be made within the period, and too many attempts are made, then the attempt is not allowed, the modem returns a DELAYED (if a call may be made later) or

- Minimum delay in seconds between successive dial attempts
- Number of successive dial attempts after which (c) applies
- Minimum delay in seconds between successive dial attempts after (b) unsuccessful dial attempts
- Maximum number of dial attempts permitted in a series of dial attempts
- Blacklisting period in minutes for each series of dial attempts

TECHNICAL SPECIFICATIONS

Configurations and Data Rates

The Z02215 can be configured to any of the V.22bis operation modes. Table 8 provides the selectable options, the supported data rate, and the baud rate, and frequency to be modulated.

Data Encoding

The data encoding for the Z02215 meets ITU–T recommendations as well as Bell standards.

Table 8. Selectable Configurations

Configuration	Modulation ^{1,2}	Carrier Frequency	Data Rate (bps)	Symbol Rate (baud)	Bits Per Symbol	Constellation Points
V.22 bis 2400	QAM	1200/2400	2400	600	4	16
V.22 bis 1200	DPSK	1200/2400	1200	600	2	4
V.22 1200	DPSK	1200/2400	1200	600	2	4
V.23 1200/75	FSK	1700/420	1200/75	1200/75	1	–
V.21	FSK	1080/1750	300	300	1	–
Bell 212A	DPSK	1200/2400	1200	600	2	4
Bell 103	FSK	1170/2125	300	300	1	–
Bell 202/ Bell 202T 1200/150	FSK	1700/437	1200/150	1200/150	1	–

Notes:

1. QAM is Quadrature Amplitude Modulation FSK is Frequency Shift Key
2. Tone is Single or Dual Tone (DTMF), TM is Trellis Modulation, DPSK is Dual Phase Shift Keying

TRANSMITTED DATA SPECTRUM

The transmitted data spectrum, with compromised equalization disabled, is shaped in the baseband of the finite

impulse response (FIR) filter. Table 9 reflects the spectrum characteristics.

Table 9. Spectral Shaping

Mode	Carrier Freq	Spectral Power Shaping Function
V.22	1200/2400	square root 75% Raised Cosine at 600 baud
V.22bis	1200/2400	square root 75% Raised Cosine at 600 baud
Bell 212A	1200/2400	square root 75% Raised Cosine at 600 baud

Note: The carrier and the spectral shaping are selected automatically according to the Configuration.

ACTIVE HYBRID CIRCUIT AND RELAY DRIVER

An active hybrid circuit is added to the Analog Front End (AFE) of the Z02215 to improve the received signal quality level by 20dB and to improve the modem performance. The on-chip active hybrid reduces system level costs by reducing the requirement for external components making the designs cost effective and space efficient.

The 2-wire to 4-wire hybrid interfaces to Telecom coupling transformers in the Data Access Arrangement (DAA). The off-hook and shunt relay drivers provides a drive capability of 30 mA to allow the use of commonly available mechanical Telecom relays.

OPERATING NOTES

Dynamic Power Management

The Z02215 incorporates a low-power SLEEP mode. In this mode, the clock is stopped.

The modem controller software automatically puts the modem’s data pump into a power-saving SLEEP mode when it is not in use. The modem controller software also puts the modem controller to SLEEP when possible.

This sleep feature operates transparently to the modem’s operation. Approximately 58 mA of power is saved when both the modem data pump and controller are put in SLEEP mode.

When the Modem Controller is in SLEEP mode, it stays asleep until an interrupt is issued for a condition, such as:

- Start bit is received from the terminal.
- Telephone line ring is detected from the telephone line interface

The modem controller cannot be in SLEEP mode if dial blacklisting is enabled in the country parameters and is being timed. The modem controller cannot be in SLEEP mode if AT&D3 is set because a DTR ON-to-OFF transition cannot change the modem’s state out of SLEEP mode.

Clock Oscillator Description

Clock. The Z02215 on-chip oscillator has a high-gain, parallel-resonant amplifier, for connection to a crystal (XTAL is Output, EXTAL is Input). The crystal is AT cut, 24.576 MHz, with a series resistance (RS) of less than or equal to 100 Ohms.

The crystal is connected across XTAL and EXTAL using the vendor’s recommended capacitor values from each pin directly to the device Ground pin to reduce ground-noise injection into the oscillator.

Note: For better noise immunity, the capacitors must be tied directly to the device Ground pin (V_{SS}).

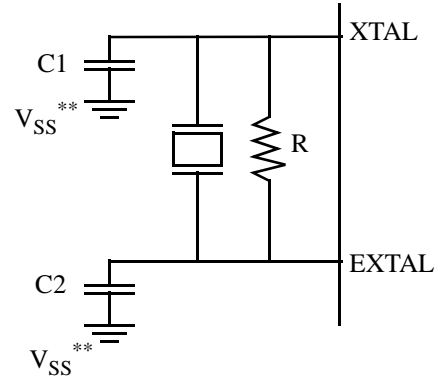

Ceramic Resonator or Crystal
 C1, C2 = 22 pF TYP*
 R = 100K - 1M Ω
 f = 8 MHz

* Preliminary value including pin parasitics
 ** Device ground pin

Figure 5. Oscillator Configuration

Table 10. Crystal Specifications

Parameter	Value
Temperature Range (Standard)	0°C to +70°C
Temperature Range (Extended)	-40°C to +85°C
Nominal Frequency @ 25°C	24.576 MHz
Frequency Tolerance @ 25°C	±20 PPM
Temperature Stability @ 0°C to 70°C	±25 PPM
Calibration Mode	Parallel Resonant
Shunt Capacitance	7 pF Max.
Load Capacitance	20 ±0.3 pF
Drive Level	1.0 mW max.
Aging, per Year Max.	±5 PPM
Oscillation Mode	Fundamental
Series Resistance	100 Ω max.
Max. Frequency Variation with 28.8 or 35.2 pF load	±30 PPM

Country Configuration

The Z02215 contains modem controller code that is targeted to operate over a North America-style telephone network with the DAA configuration illustrated in the schematics at the end of this product specification. The customer may choose to configure the modem for use on other telephone networks. This capability is enabled by the addition of a serial EEPROM to hold various country tables. The EEPROM may be omitted from the application if the customer chooses to operate with the default North America-style parameters.

The Z02215 provides a means of loading information into the EEPROM for setting homologation or country approval tables. One way to set these tables is by choosing the desired geographic region to be served in a DOS program, supplied by ZiLOG, called Diplomat™. This program interfaces to the modem through the serial port using hidden AT commands, allowing reprogramming of the EEPROM.

Typical Performance Data

The Bit Error Rate (BER) and Block Error Rate (BLER) curves in Figure 6 are *representative* of a typical V.22 and V.22bis performance over a variety of signal-to-noise ratio (SNR) conditions.

Note: Modems usually exhibit lower bit error rates receiving in the low band as opposed to the high band.

For each BER curve illustrated, one connection is made, after which the Adaptive Equalizer (AEQ) was frozen. BER measurements are taken in 1 dB SNR steps from low noise levels to high noise levels. These tests were conducted using a Consultronics TCS500 Telephone Line Simulator and a

Hewlett Packard 4951B protocol analyzer/BERT tester, under the following conditions:

Line Simulation	Flat
Transmit Level	-10 dBm
Receive Level	-30.0 dBm
Data Transmitted	511 pseudorandom pattern
Number of Bits Sent	10,000,000 in V.22bis, V.22 and Bell 212A.
Bits per Block	1,000
AEQ	Frozen after link establishment
Noise Calibration	C-message

Data Access Arrangement

Figure 8 indicates an example DAA configuration for North America. Isolation transformer (T1) couples the primary (line) and secondary (modem) sides, while providing high voltage isolation. This *wet* transformer (allowing DC current) simplifies the circuit and reduces the cost of the DAA.

On the Secondary side, the transmit (TxA+ and TxA-) and receive (RxA+ and RxA-) are combined in the 4-wire to 2-wire hybrid circuit.

On the Primary side, the off-hook relay switches the phone line between a local handset (phone) or the modem. The ring detect circuit consists of DC blocking capacitor C304, current limiting resistor R305, zener diodes CR303 and CR304, optocoupler U303, and its reverse protection diode D304. Protection elements RV301, F301, C301, and C302 (and transformer T1's isolation) provide higher voltage capability for approval in some foreign markets. C201 and C202, for example, may require replacement by Metal Oxide Varistors (MOVs) or Gas Discharge Tubes (GDTs). The shunt relay reduces the DAA impedance during pulse dialing. This relay is required for certain country approvals. The CID relay provides a signal path (through C4) to receive Caller ID signals without taking the line off-hook.

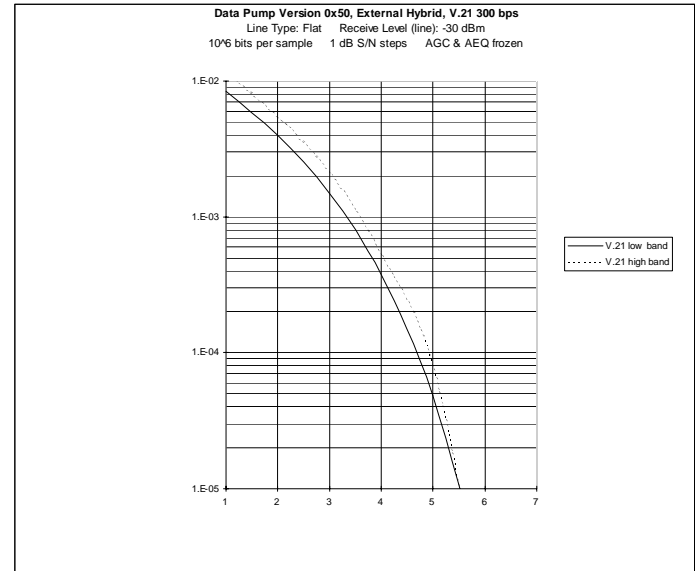
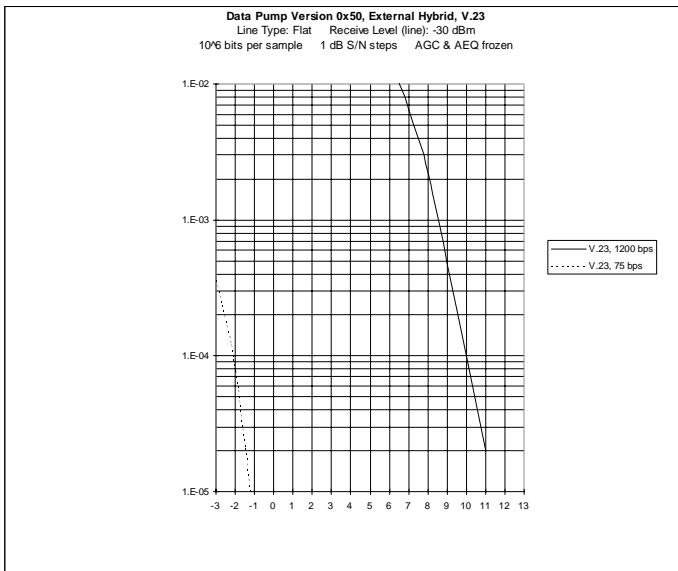
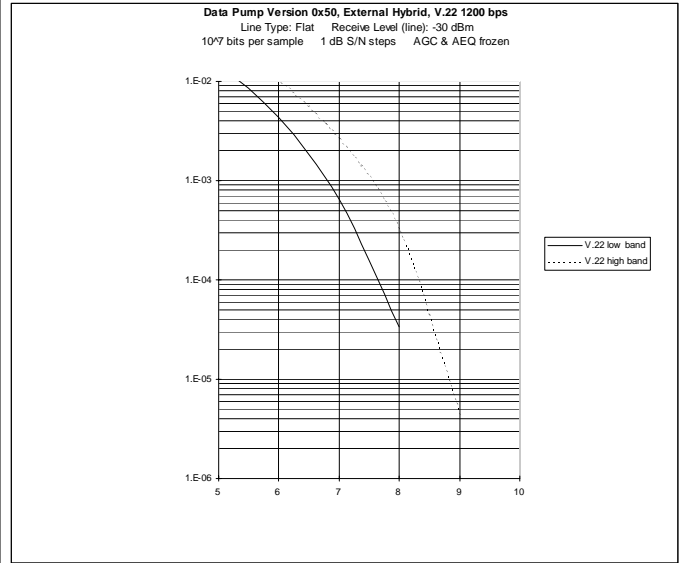
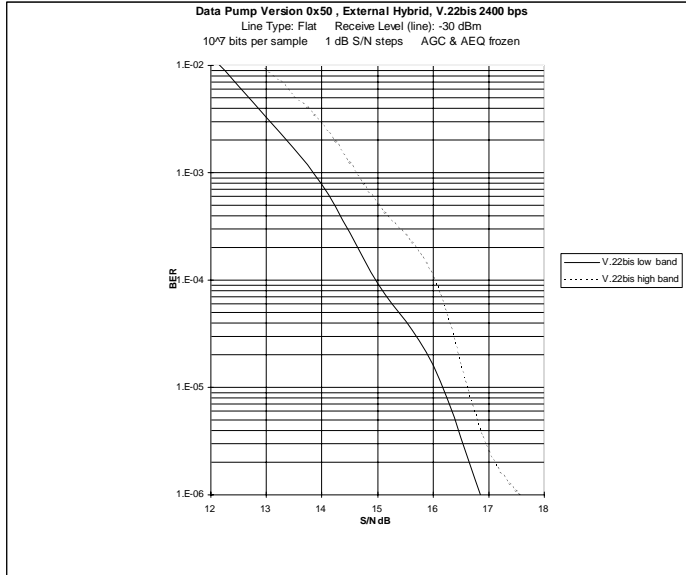

Figure 6. Typical Performance Data

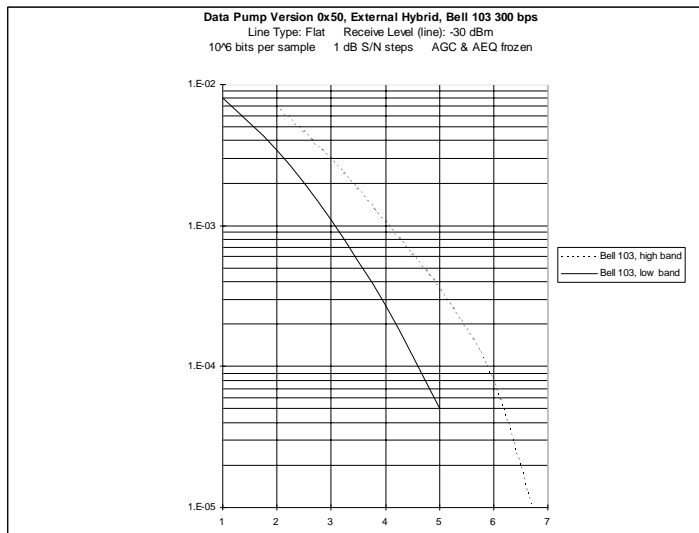
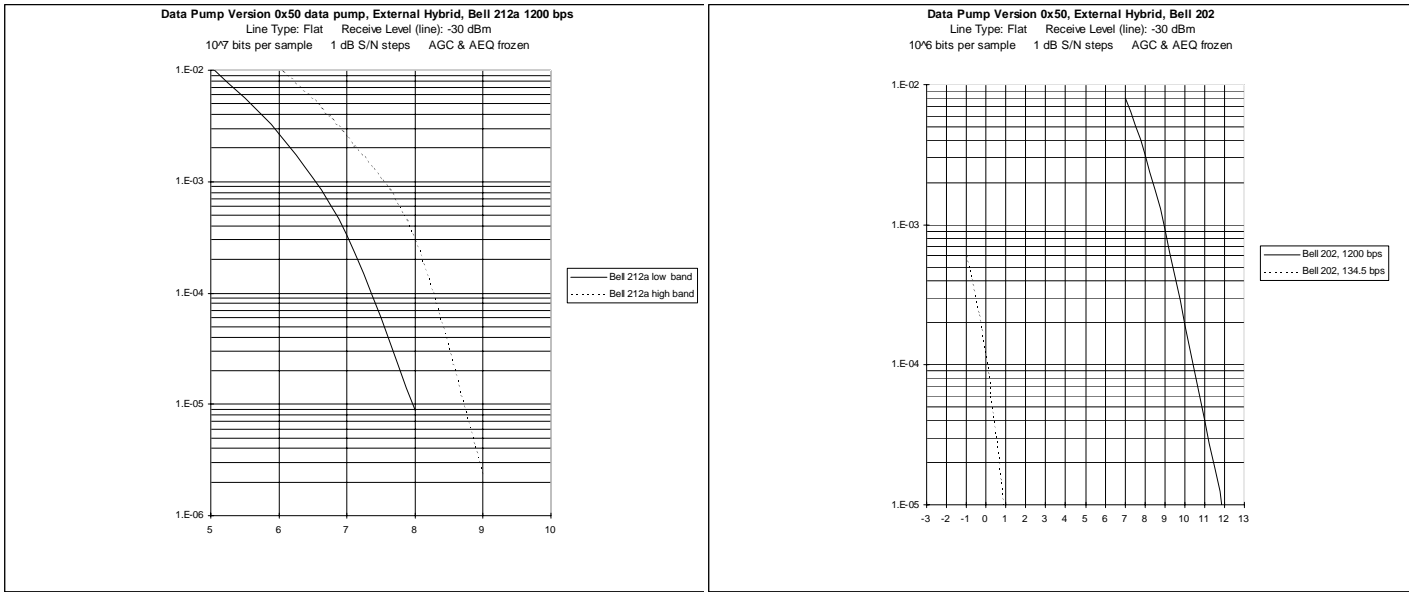

Figure 6 (Continued). Typical Performance Data

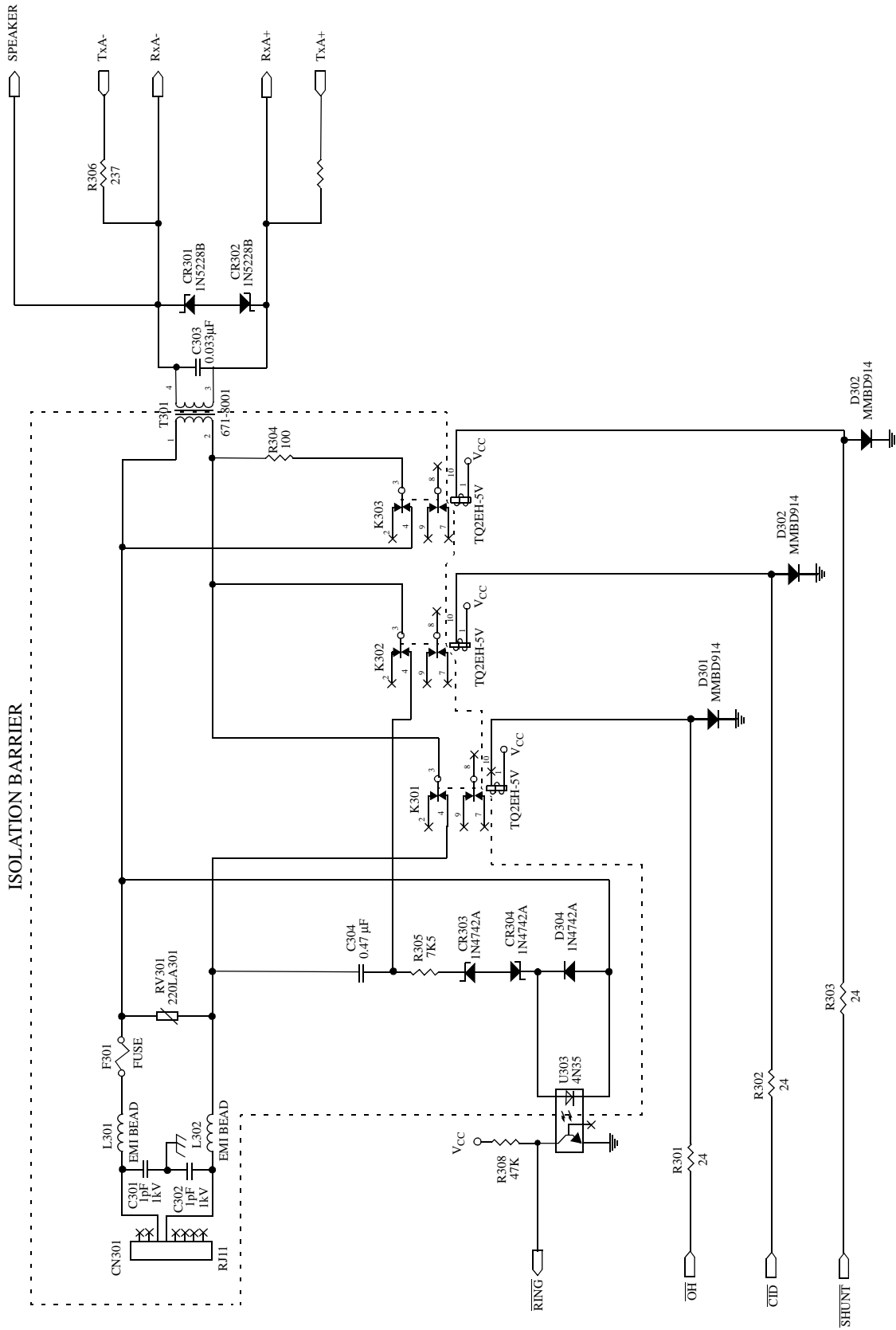

Figure 8. Data Access Arrangement (DAA)

ABSOLUTE MAXIMUM RATINGS

Parameter	Min	Max	Units	Notes
Operating Temperature (T _{OPR})	0	+70	C	
Extended Temperature (T _{EXT})	-40	85	C	
Storage Temperature (T _{STG})	-55	+150	C	
Voltage on any Pin with Respect to V _{SS}	-0.6	+7	V	1
Voltage on V _{DD} Pin with Respect to V _{SS}	-0.3	+7	V	
Voltage on XTAL and $\overline{\text{RESET}}$ Pins with Respect to V _{SS}	-0.6	V _{DD} +1	V	2
Total Power Dissipation		TBD	W	
Maximum Allowable Current out of V _{SS}		TBD	mA	
Maximum Allowable Current into V _{DD}		TBD	mA	
Maximum Allowable Current into an Input Pin	TBD	TBD	μA	3
Maximum Allowable Current into an Open-Drain Pin	-600	TBD	μA	4
Maximum Allowable Output Current Sunked by Any I/O Pin		TBD	mA	
Maximum Allowable Output Current Sourced by Any I/O Pin		TBD	mA	

Notes:

1. This parameter applies to all pins except XTAL pins and where otherwise noted.
2. There is no input protection diode from pin to V_{DD} and current into pin is limited to ±600 μA
3. Excludes XTAL pins.
4. Device pin is not at an output low state.

Stresses greater than those listed under Absolute Maximum Ratings may cause permanent damage to the device. This rating is a stress rating only. Functional operation of the device at any condition above those indicated in the operational sections of these specifications is not implied. Exposure to absolute maximum rating conditions for an extended period may affect device reliability.

Total power dissipation must not exceed 1.21 W for the package. Power dissipation is calculated as follows:

$$\begin{aligned} \text{Total Power} &= V_{DD} \times [I_{DD} - (\text{sum of } I_{OH})] \\ \text{Dissipation} &+ \text{sum of } [(V_{DD} - V_{OH}) \times I_{OH}] \\ &+ \text{sum of } (V_{OL} \times I_{OL}) \end{aligned}$$

STANDARD TEST CONDITIONS

The DC Parameters are be tested according to the DC Characteristics detailed in Table 13. The Z02215 tester has active loads which are used to test the loading for I_{OH} and I_{OR}.

Voltage Supply Range:

$$+4.5 \text{ V} \leq V_{CC} \leq + 5.5 \text{ V}$$

Available Operating Temperature Range

Standard = 0°C to +70°C
 Extended = -40°C to +85°C

All AC parameters assume a load capacitance of 100 pF. Add 10 ns delay for each 50 pF increase in load up to a maximum of 150 pF for the data bus and 100 pF for address and control lines.

POWER REQUIREMENTS

The modem power and environmental requirements are indicated in Table 11 and Table 12.

Table 11. Power Requirements

Voltage	Current Typical @ 25°C	Current Maximum @ 0°C
+5 V _{DC} , Operating	TBD	TBD
+5 V _{DC} , Sleep	TBD	TBD

Note: All voltages are $\pm 5\%$ DC and must exhibit ripple less than 0.1V (peak to peak). If a switching supply is used, the frequency may be between 20 kHz and 150 kHz. There must be no component of the switching frequency present outside of the supply greater than a 500 μ V peak.

Table 12. Environmental Requirements

Parameter	Value
Ambient Temperature Under Bias (Standard Temperature Range)	0°C to +70°C
Extended Temperature	-40°C to +85°C
Storage Temperature	-55°C to +150°C
Voltage on any pin to V _{SS}	-0.3V to +7V
Power Dissipation	TBS
Soldering Temperature 10 sec	+230°C

DC CHARACTERISTICS

Table 13. DC Characteristics

Parameter	Description	Test Conditions	Minimum	Typical	Maximum	Units
Pin Types I and I/O: Input and Input/Output						
V _{IH}	Input High Voltage		2.0	-	V _{CC} + 0.3	V
V _{IL}	Input Low Voltage		-0.3	-	0.8	V
I _L	Input Leakage Current	GND < V ₀ < V _{DD}	-	-	10	μ A
Pin Types O and IO: Output and Input/Output						
V _{OH}	Output High Voltage	I _{OH} = -200 μ A	2.4	-	-	V
V _{OL}	Output Low Voltage	I _{OI} = -2.2 mA	-	-	0.4	V
I _{OZ}	Tri-state Leakage Current	GND < V ₀ < V _{DD}	-	-	1.0	μ A
Pin Types I-PU & I-PD: Input with Internal Pull-Up/Pull-Down Resistor						
V _{IH}	Input High Voltage		TBD		TBD	V
V _{IL}	Input Low Voltage		TBD		TBD	V
I _{IL}	Input Current	GND < V ₀ < V _{DD}	TBD		TBD	mA
Pin Type XI: Crystal Input						
V _{IH}	Input High Voltage		V _{CC} - 0.6		V _{CC} + 0.3	V
V _{IL}	Input Low Voltage		-0.3		0.6	V

Table 13. DC Characteristics (Continued)

Parameter	Description	Test Conditions	Minimum	Typical	Maximum	Units
Pin Type O-OD: Output with Open-Drain						
V_{OL}	Output low Voltage	$I_{OI} = 2.2 \text{ mA}$	2.4	–	–	V
I_{OZ}	Tri-state Leakage Current	$GND < V_0 < V_{DD}$	–	–	1.0	μA
Pin Type XO: Crystal Output						
V_{OH}	Output High Voltage	$I_{OH} = 1.0 \text{ mA}$	TBD		TBD	V
V_{OL}	Output Low Voltage	$I_{OI} = -1.0 \text{ mA}$	TBD		TBD	V
Pin Type AI: Analog Input						
V_{DC}	Input Bias Offset		$V_{REF} - 15$	V_{REF}	$V_{REF} + 15$	mV
V_{OFFI}	Input Offset (Differential)		–20	0	+20	mV
I_L	Input Current		–100	–	100	mA
C_{IN}	Input Capacitance		–	10	–	pF
R_{IN}	Input Resistance		–	20	–	$\text{k}\Omega$
Pin Type AO: Analog Output						
V_O	Analog Output Voltage		$V_{REF} - 1.163$	V_{REF}	$V_{REF} + 1.163$	mV
V_{OFF}	Output DC Offset		$V_{REF} - 40$	V_{REF}	$V_{REF} + 40$	mV
V_{OFFO}	Output DC Offset (differential)		–40	0	+40	mV
R_O	Output Resistance		–	0.8	–	Ω
C_O	Output Capacitance		–	10	–	pF
Z_I	Load Impedance		400	600	Infinite	Ω
Pin Type PWR: Power and Ground						
V_{DD}	Digital Supply Voltage	Voltage	4.5	5	5.5	V
AV_{DD}	Analog Supply Voltage		V_{DD}	V_{DD}	V_{DD}	V
I_{DD1}	Digital Supply Current	Operating	–	TBD	TBD	mA
I_{ADD1}	Analog Supply Current	Operating	–	TBD	TBD	mA
I_{DD2}	Digital Supply Current	SLEEP Mode	–	TBD	TBD	μA
I_{ADD2}	Analog Supply Current	SLEEP Mode	–	TBD	TBD	μA

CAPACITANCE

$T_A = 25^\circ\text{C}$, $V_{CC} = GND = 0\text{V}$, $f = 1.0 \text{ MHz}$, unmeasured pins to GND.

Parameter	Minimum	Maximum
Input capacitance	0	12 pF
Output capacitance	0	12 pF
I/O capacitance	0	12 pF

Table 14. Microprocessor Interface Timing

Reset Timing	Parameter	Minimum	Typical	Maximum	Units
Reset Pulse Width		1.0	–	–	μs

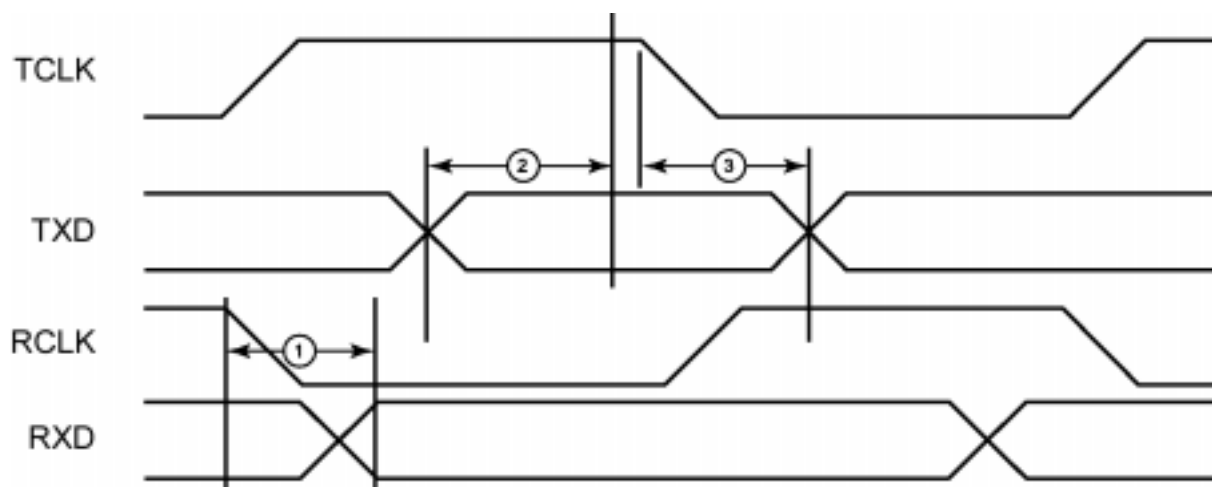

Figure 9. Serial Port Timing Diagram

Table 15. Serial Interface Timing

Description	Parameter	Minimum	Typical	Maximum	Units
RXD Data Valid Delay Time	1	–	12	–	ns
TXD Data Setup Time	2	100	–	–	ns
TXD Data Hold Time	3	100	–	–	ns

Table 16. Analog Characteristics

Description	Parameter	Minimum	Typical	Maximum	Units
Input impedance of transformer interface	1	400	1200	–	Ω
3 dB point of transformer interface	2	21	26.5	32.5	kHz
External integration capacitance Type NPO (COG)	3	73	82	90	pF

Note: NPO and COG are synonymous terms for an industry standard dielectric material used for ceramic capacitors which provides a very low temperature coefficient of capacitance (± 30 ppm per $^{\circ}\text{C}$) and voltage coefficient of capacitance (under 0.01% per Volt). It also has a low dissipation factor (0.1% max at 1 MHz for the values of interest).

ANALOG INPUTS: TYPE AI

AC Characteristics	Symbol	Minimum	Typical	Maximum	Units
Input Impedance (DC to V_{REF})	Z_{IN}	15K	25K	–	Ω
Power Supply Rejection	P_{SRRi}	40	–	–	dB
Input Current	I_i	–80	–	80	mA
Idle Channel Noise (3950 Hz Bandwidth)	I_{CNi}	–	–	–72	dBm
Signal to Distortion	S_{TDi}	30	–	–	dB

The characteristics below are provided for information only. They are not tested except in the functional test vectors.

Characteristics	Symbol	Minimum	Typical	Maximum	Units
Input Capacitance	C_{IN}	–	10	–	pF
Input Bias	V_{DCOFF}	–	+2.5	–	V
Analog Input Voltage (peak differential), (23)	V_{PKI}	–2.362	–	+2.362	V
Analog Input Voltage (per RXI+, RXI– pin)	V_{PKIP}	–1.181	–	+1.181	V

ANALOG INPUTS: TYPE A0

AC Characteristics	Symbol	Minimum	Typical	Maximum	Units
Power Supply Rejection	P_{SRRO}	40	–	–	dB
Signal to Distortion	S_{TD0}	35	–	–	dB
Idle Channel Noise (3950 Hz Bandwidth)	I_{CNO}	–	–	–72	dBm
Out-of-Band Noise	N_{q0}				dBm
4–8 kHz	–	–	–20		dBm
8–12 kHz	–	–	–40		dBm
12 kHz and above in 4 kHz bandwidths	–	–	–55		dBm

Characteristics	Symbol	Minimum	Typical	Maximum	Units
Output Impedance	Z_{OUT}	–	0.80	–	Ω
Output Capacitance	C_{OUT}	–	10	–	pF
Analog Output Voltage (peak differential), (24)	V_{PKO}	–2.375	–	+2.375	V
Load Impedance (25)	ZI	400	600	–	–

PACKAGE INFORMATION

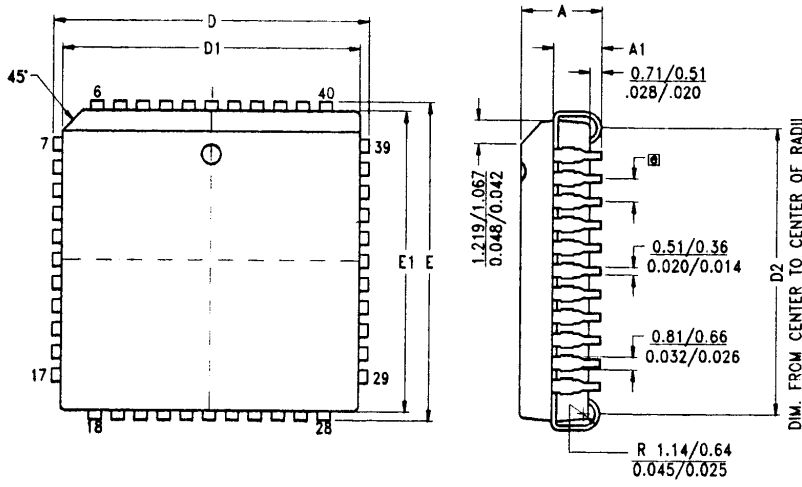

SYMBOL	MILLIMETER		INCH	
	MIN	MAX	MIN	MAX
A	4.27	4.57	0.168	0.180
A1	2.41	2.92	0.095	0.115
D/E	17.40	17.65	0.685	0.695
D1/E1	16.51	16.66	0.650	0.656
D2	15.24	16.00	0.600	0.630
Ⓜ	1.27 TYP		0.050 TYP	

- NOTES:
 1. CONTROLLING DIMENSION : INCH
 2. LEADS ARE COPLANAR WITHIN 0.004".
 3. DIMENSION : MM INCH

Figure 10. 44-Lead PLCC Package Diagram

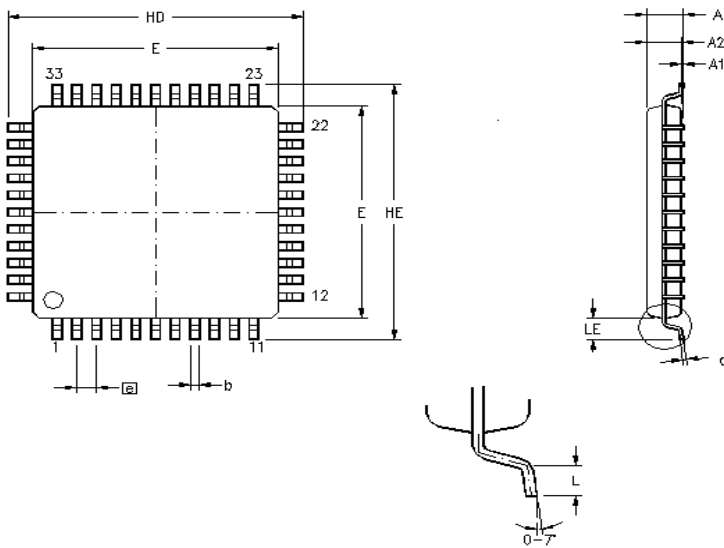

SYMBOL	MILLIMETER		INCH	
	MIN	MAX	MIN	MAX
A	1.40	1.60	0.055	0.063
A1	0.05	0.15	0.002	0.006
A2	1.35	1.45	0.053	0.057
b	0.30	0.45	0.012	0.018
c	0.09	0.20	0.004	0.008
HD	11.75	12.25	0.463	0.482
D	9.90	10.10	0.390	0.398
HE	11.75	12.25	0.463	0.482
E	9.90	10.10	0.390	0.398
Ⓜ	0.80 BSC		0.031 BSC	
L	0.45	0.75	0.018	0.030
LE	1.00 REF		0.039 REF	

1. CONTROLLING DIMENSIONS : mm
 2. MAX. COPLANARITY : .10mm / 0.004"

Figure 11. 44-Lead VQFP Package Diagram

ORDERING INFORMATION

Z02215

Z0221524VSCR4508	PLCC	24.576 MHz	Standard Temp
Z0221524VECR4508	PLCC	24.576 MHz	Extended Temp
Z0221524ASCR4508	VQFP	24.576 MHz	Standard Temp
Z0221524AECR4508	VQFP	24.576 MHz	Extended Temp

For fast results, contact your local ZiLOG sales office for assistance in ordering the part required.

CODES

- Speed** 24 = 24.576 MHz
- Package** V = Plastic Leaded Chip Carrier
A = Very small Quad Flat Pack
- Temperature** S = 0°C to +70°C (Standard)
E = -40°C to +85°C (Extended)
- Environmental** C = Plastic Standard
- ROM Code** R4508 = ROM code number 4508 (DSP ROM code Version 0x50, Controller ROM code version 1.2)

Example

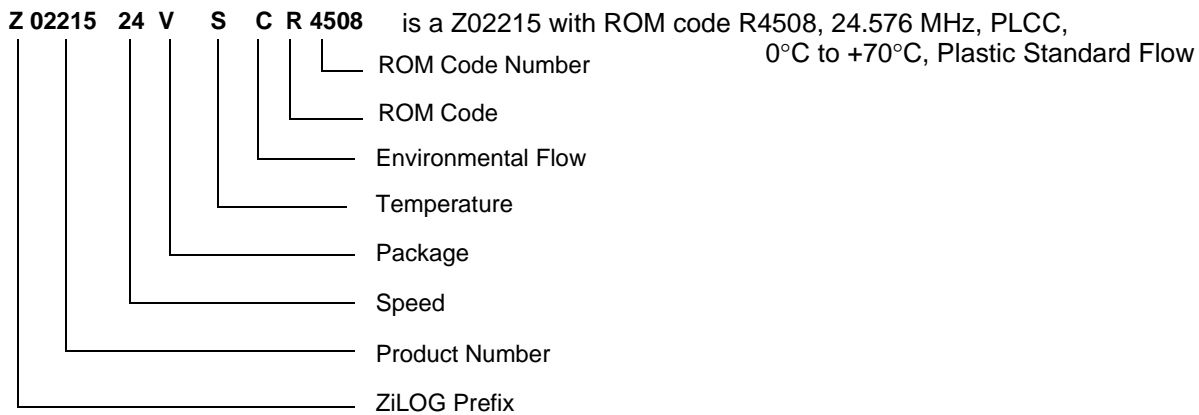

Pre-Characterization Product:

The product represented by this Product Specification (PS) is newly introduced and ZiLOG has not completed the full characterization of the product. The PS states what ZiLOG knows about this product at this time, but additional features or non-conformance with some aspects of the PS may be found, either by ZiLOG or its customers in the course of further application and characterization work. In addition, ZiLOG cautions that delivery may be uncertain at times, due to start-up yield issues.

Development Projects:

Customer is cautioned that while reasonable efforts are employed to meet performance objectives and milestone dates, development is subject to unanticipated problems and delays. No production release is authorized or committed until the Customer and ZiLOG have agreed upon a Customer Procurement Specification for this project.

Low Margin:

Customer is advised that this product does not meet ZiLOG’s internal guardbanded test policies for the specification requested and is supplied on an exception basis. Customer is cautioned that delivery may be uncertain and that, in addition to all other limitations on ZiLOG liability stated on the front and back of the acknowledgment, ZiLOG makes no claim as to quality and reliability under the CPS. The product remains subject to standard warranty for replacement due to defects in materials and workmanship.

© 1999 by ZiLOG, Inc. All rights reserved. No part of this document may be copied or reproduced in any form or by any means without the prior written consent of ZiLOG, Inc. The information in this document is subject to change without notice. Devices sold by ZiLOG, Inc. are covered by warranty and patent indemnification provisions appearing in ZiLOG, Inc. Terms and Conditions of Sale only.

ZiLOG, Inc. makes no warranty, express, statutory, implied or by description, regarding the information set forth herein or regarding the freedom of the described devices from intellectual property infringement. ZiLOG, inc. makes no warranty of merchantability or fitness for any purpose.

ZiLOG, Inc. shall not be responsible for any errors that may appear in this document. ZiLOG, Inc. makes no commitment to update or keep current the information contained in this document.

ZiLOG’s products are not authorized for use as critical components in life support devices or systems unless a specific written agreement pertaining to such intended use is executed between the customer and ZiLOG prior to use. Life support devices or systems are those which are intended for surgical implantation into the body, or which sustains life whose failure to perform, when properly used in accordance with instructions for use provided in the labeling, can be reasonably expected to result in significant injury to the user.

ZiLOG, Inc.
910 East Hamilton Avenue, Suite 110
Campbell, CA 95008
Telephone (408) 558-8500
FAX 408 558-8300
Internet: <http://www.zilog.com>