

### Product Description:

The TQM7638 is a 3V, 3 stage SiGe HBT Power Amplifier Module designed for use in mobile phones. Its extremely small 4x4mm package makes it ideal for today's extremely small data enabled phones. Its RF performance meets the requirements for products designed to IS-95/98 standards. The TQM7638 provides the capability to be operated in one, two, or continuous quiescent current modes. In digital quiescent current mode operation, the TQM7638 is controlled from the base-band processor using a CMOS compatible  $I_{CO}$  control voltage. Overall current consumption of the device is minimized by selecting the lowest  $I_{CO}$  state available for each power output level. RF input and output matching is included within the module; therefore, minimal external circuitry is required.

The TQM7638 gives excellent RF performance with low current consumption resulting in longer talk times in portable applications. The small 6mm square surface mount package is ideal for new generation small and light phones.

### Electrical Specifications:

Parameter	Min	Typ	Max	Units
Frequency	1850		1910	MHz
CDMA mode $P_{out}^1$		28		dBm
CDMA Mode Efficiency <sup>1</sup>		31		%

Note 1: Test Conditions CDMA Mode:  $V_{CC1}=3.4VDC$ ,  $V_{CC2}=3.4VDC$ ,  $V_{REF}=2.90VDC$ ,  $V_{CTRL}=0.5VDC$ ,  $T_C=25^\circ C$ ,  $P_{out} = 28.0dBm$

## TQM7638

### DATA SHEET

## 3V HBT SiGe PCS Band CDMA 4x4mm POWER AMPLIFIER MODULE

### Features

- Analog continuous bias capability with excellent linearity over 1.9 to 3.0VDC and temperature stability over  $-30C$  to  $85C$
- Excellent PAE
- Small 10 pin 4x4mm module
- 1xRTT Compatible
- Industry compatible digital quiescent current state control
- Analog continuous bias capability
- CMOS compatible logic input
- Internally matched input and output
- Full ESD Protection
- Low leakage current

### Applications

- Tri Mode CDMA phones
- PCS Band CDMA based mobile phones

# TQM7638 - Preliminary Data Sheet

## Absolute Maximum Ratings

Symbol	Parameter	Absolute Maximum Value	Units
V <sub>CC1</sub> , V <sub>CC2</sub>	Power Supply Voltage, no RF Applied	-0.5 to 6.0	VDC
	RF Applied	-0.5 to 5.0	
V <sub>REF</sub> , V <sub>CTRL</sub>	Bias reference voltages (V <sub>REF</sub> ) and bias control voltage (V <sub>CTRL</sub> ).	-0.5 to 5.0	VDC
P <sub>DISS</sub>	Power Dissipation	2.5	W
T <sub>C</sub>	Case Temperature, Survival	-40 to +100	°C
T <sub>STG</sub>	Storage Temperature	-40 to +150	°C
R <sub>FIN</sub>	DC Grounded RF input, 50ohm RF impedance	0 to 0V	VDC
R <sub>FOUT</sub>	DC Blocked RF output, 50 ohm RF impedance	-20V to 20V	VDC

Note: The part may not survive all maximums applied simultaneously.

## CDMA Mode Electrical Characteristics<sup>1,2,3</sup>

Parameter	Conditions	Min.	Typ/Nom	Max.	Units
RF Frequency		1850		1910	MHz
P <sub>out</sub> , I <sub>CO</sub> -hi	V <sub>CTRL</sub> = low		28		dBm
Large Signal Gain, I <sub>CO</sub> -hi	P <sub>out</sub> = 28dBm, V <sub>CTRL</sub> = low		29		dB
Large Signal Gain, I <sub>CO</sub> -low	P <sub>out</sub> = 15dBm, V <sub>CTRL</sub> = high		26		dB
Gain Variation vs. Temp.	-30 to 85 °C, P <sub>out</sub> =28dBm		+/-2.5		dB
Quiescent Current, I <sub>CO</sub> -hi	V <sub>CTRL</sub> = low		124		mA
Quiescent Current, I <sub>CO</sub> -low	V <sub>CTRL</sub> = high		82		mA
I <sub>CC</sub>	P <sub>out</sub> = 28dBm, V <sub>CTRL</sub> = low		607		mA
Power Added Efficiency	P <sub>out</sub> = 28dBm, V <sub>CTRL</sub> = low		31		%
Adjacent Channel Power (ACP)	P <sub>out</sub> = 28dBm, V <sub>CTRL</sub> = low, IS-95 Standard		-49	-	dBc
Alternate Channel Power (ALT)	P <sub>out</sub> = 28dBm, V <sub>CTRL</sub> = low, IS-95 Standard		-58		dBc
Output Power Low-Power I <sub>cq</sub> state	ACPR=-47dBc, V <sub>CTRL</sub> = high, IS-95 Standard		15		dBm

**CDMA Mode Electrical Characteristics<sup>1,2,3</sup> (cont'd)**

Noise Power in Rx band	P <sub>out</sub> =28dBm, V <sub>CTRL</sub> = low, IS-95 Standard	-88			dBm/30KHz
Input VSWR	Both I <sub>CO</sub> -hi & I <sub>CO</sub> -low	2:1			
Second Harmonic	P <sub>out</sub> =+28dBm, V <sub>CTRL</sub> = low, IS-95 Standard		<-35		dBc
Third Harmonic	P <sub>out</sub> =+28dBm, V <sub>CTRL</sub> = low, IS-95 Standard		<-45		dBc
Recommended Supply Voltage		3.2	3.4	4.2	VDC
Reference Voltage		2.85	2.9	2.95	VDC
V <sub>REF</sub> Current, I <sub>CO</sub> -hi	Hi-Power Mode, V <sub>CTRL</sub> = low		14		mA
V <sub>REF</sub> Current, I <sub>CO</sub> -low	Low-Power Mode, V <sub>CTRL</sub> = high		6		mA
Leakage Current	V <sub>CTRL</sub> = low, V <sub>REF</sub> =0VDC		10		μA
Logic Current (V <sub>CTRL</sub> )				100	μA
Logic Voltage (V <sub>CTRL</sub> )	High	1.7	2.0	3.5	VDC
	Low	0	0.25	0.5	VDC
Recommended Operating Temperature		-30		+85C	
Ruggedness	No Damage, P <sub>out</sub> =+28dBm, V <sub>CTRL</sub> = low, IS-95 Standard			10:1	
Stability	No Oscillations, P <sub>out</sub> =+28dBm, V <sub>CTRL</sub> = low, IS-95 Standard			10:1	

**Note 1:** Test Conditions: V<sub>CC1</sub>=3.4VDC, V<sub>CC2</sub>=3.4VDC, V<sub>REF</sub>=2.90VDC, V<sub>CTRL</sub>=0.5VDC, RF=1880MHz, T<sub>C</sub> = 25°C unless otherwise specified.

**Note 2:** Min./Max. limits are at +25°C case temperature unless otherwise specified.

**Note 3:** TriQuint Test Board.

Application/Test Circuit:

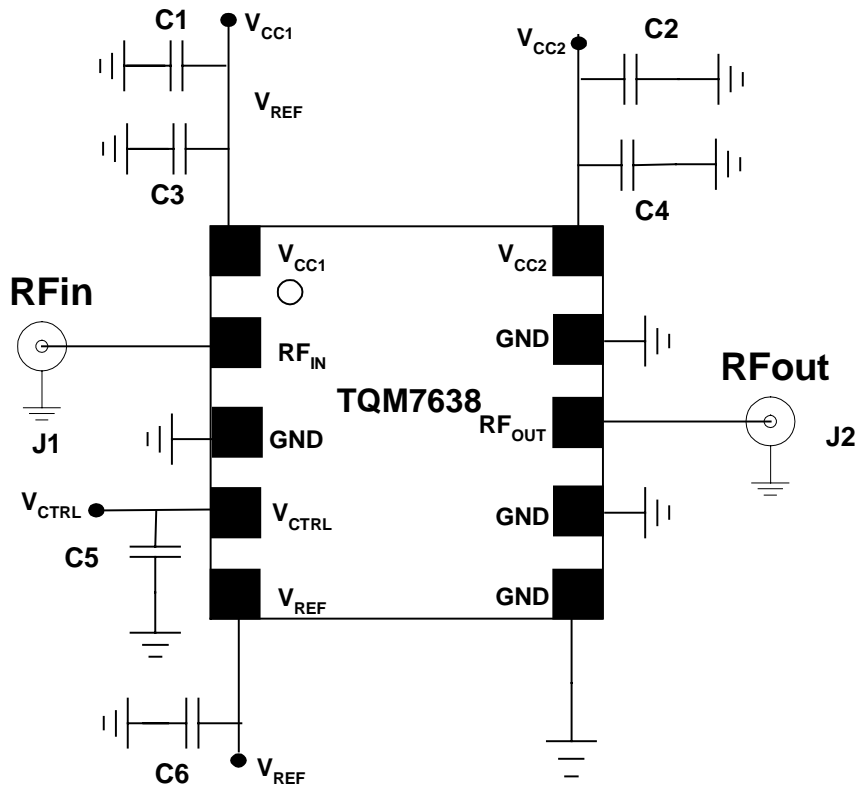

*U.S. PCS Band, 1850 - 1910 MHz*

*Bill of Material for TQM7638 Power Amplifier Module Application/Test Circuit\**

Component	Reference Designator	Part Number	Value, Cellular Band	Size
Power Amplifier Module		TQM7638		8pin/6mm square
RF Connector	J1, J2			
Capacitor	C3		100pF	0402
Capacitor	C3, C4, C5, C6		0.1μF	0402
Capacitor	C1, C2		10μF	1210

\*May vary due to printed circuit board layout and material

**Product Description:**

The TQM7638 is a three stage SiGe HBT power amplifier module in a cascade configuration intended for use in CDMA PCS band transmit paths.

**Operation**

The operation modes of the TQM7638 are determined based on the setting of  $V_{CNTRL}$  and  $V_{REF}$ . The truth table below defines the operating mode. Also, If the TQM7638 will be used in continuous bias mode  $V_{CNTRL}$  must be connected on the circuit board to ground.

Operating Mode	$V_{CNTRL}$	$V_{REF}$
High Power	Low	>2.7VDC
Low-Power	High	>2.7VDC
Continuous Bias	Gnd	~1.9 to 3.0VDC
Off	Low	0VDC

**Application**

The applications circuit for the TQM7638 is very simple since most of the critical components are included inside the module. There are several important considerations when using the module in a phone design.

First of all, it is important that the source impedance of the  $V_{CC}$  power supply be very low. This is because the high current demand during the modulation peaks of the CDMA waveform can introduce voltage ripple at the symbol rate that will introduce additional inter-modulation distortion or Adjacent Channel Power distortion at the output of the power amplifier. If the power amplifier has a quiescent current of 100 mA and a peak current demand in excess of 1 amp, it is possible to see 900 mA change in the current required from  $V_{CC}$  as the modulated signal moves from one extreme to the other. If the power supply source

impedance were 1 ohm, the resulting voltage ripple would be 0.9 volts which would cause the amplifier to fail it ACP requirements. Generally, the power supply source impedance should be kept as low as possible, preferably below 0.1 ohms total. Most battery technologies used in cellular telephones will support a low source impedance, but it may be necessary to supplement this in some designs with an low ESR capacitor. Ceramic or tantalum capacitors of approximately 10 micro-farads work well for this requirement.

The application circuit includes 0.1  $\mu$ F capacitors at the PA control line and  $V_{CC}$  lines to ensure proper RF bypassing. Depending on the phone board layout and circuit bypassing in other areas of the phone, some of these components may not be necessary. There are a number of VCO signals and IF signals used in a given phone design, so it is important to protect the PA module from interfering signals and to limit any interference coming from the PA itself. Care should be taken when removing any of the RF bypassing components.

One final area of concern is with excessive bypassing. If too large a value of bypassing capacitor is used on the control line, it could reduce the frequency response of the control line to the point where a specification failure could occur. Please be sure that the logic line and regulated supply lines driving the power amplifier control lines are adequate to supply peak current requirements of the bypassing capacitors chosen on the control lines.

**One Bias State Operation**

The TQM7638 can be operated using one bias state. If this mode is selected,  $V_{CNTRL}$  should be connected to ground.

**Continuous Bias State Operation**

The TQM7638 can be operated in continuous bias mode in which the  $V_{REF}$  voltage is varied from ~1.9V to 3.0V to set the PAM quiescent current as appropriate for the desired output power level. In this mode,  $V_{CNTRL}$  should be connected to ground on the phone board. Specific application circuit information for this mode is available upon request.

# TQM7638 - Preliminary Data Sheet

## Package Pin-Out:

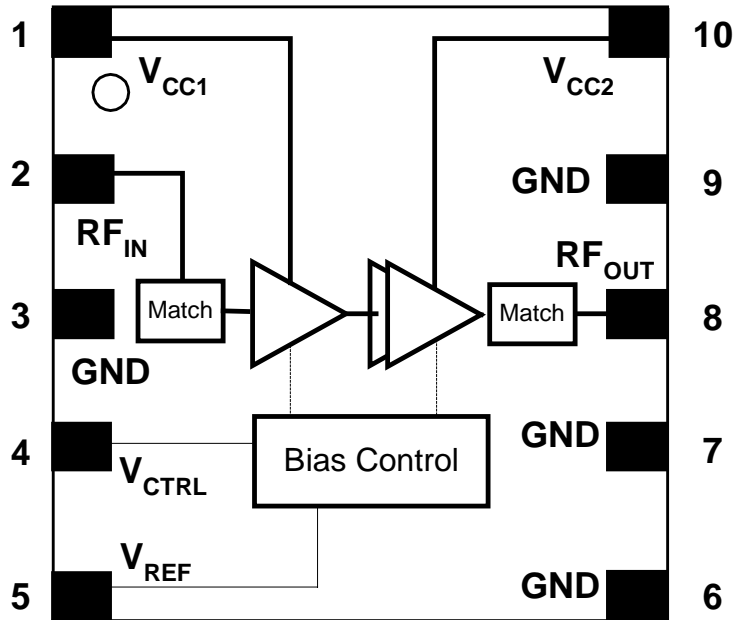

## Pin Descriptions:

Pin Name	Pin #	Description and Usage (Equivalent Circuit)
GND	Paddle	Device Ground and Heat Sink. Needs good thermal path to remove heat.
V <sub>CC1</sub>	1	Collector supply for input stage.
RFin	2	RF input. The RF circuit is DC grounded. 50 Ohm RF impedance. <div style="text-align: right;"> </div>
V <sub>CTRL</sub>	4	CMOS compatible logic level to set bias level
V <sub>REF</sub>	5	Regulated supply for setting bias. Vref is set to 0VDC to power-off the TQM7638
RFOU	8	RF output. The RF circuit is DC blocked internally. 50 ohm RF impedance.
V <sub>CC2</sub>	10	Collector supply for output stage.
GND	3, 6, 7, 9	Ground

TriQuint recommends use of several via holes to the backside ground under the Paddle.

*Recommended PC board layout to Accept 10 Pin Module Package:*

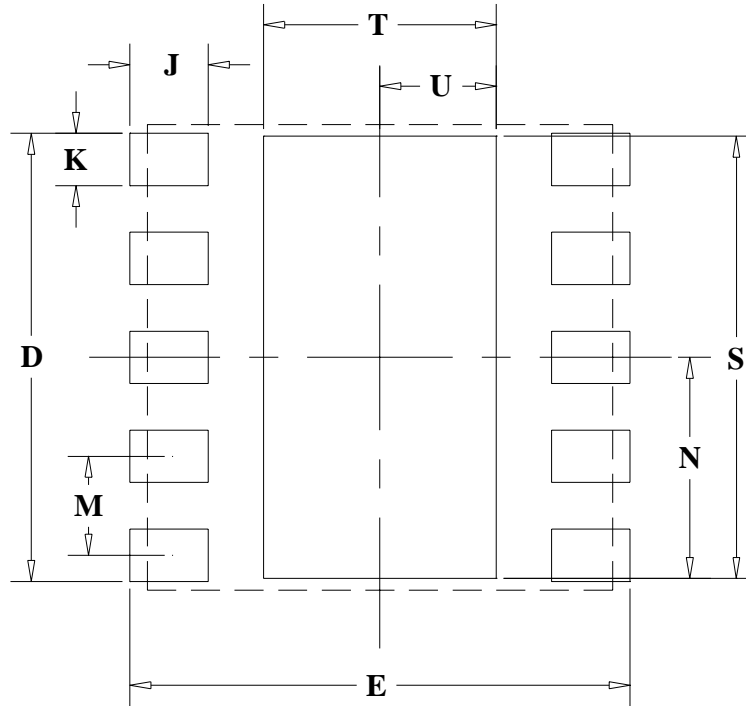

DIMENSION	MM
<b>D</b>	3.85
<b>E</b>	4.30
<b>J</b>	0.68
<b>K</b>	0.45
<b>M</b>	0.85
<b>N</b>	1.90
<b>S</b>	3.80
<b>T</b>	2.00
<b>U</b>	1.00

Notes:

- 1 Only ground signal traces are allowed directly under the package
- 2 Primary dimensions are in millimeters alternate dimensions are in inches.

# TOM7638 - Preliminary Data Sheet

Package Type: 10 Pin Plastic Module Package

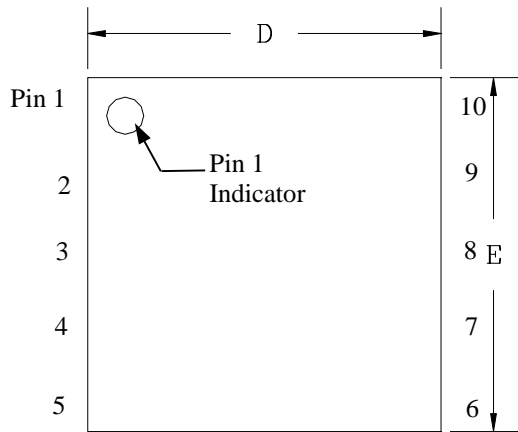

Top View

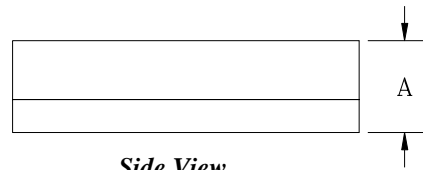

Side View

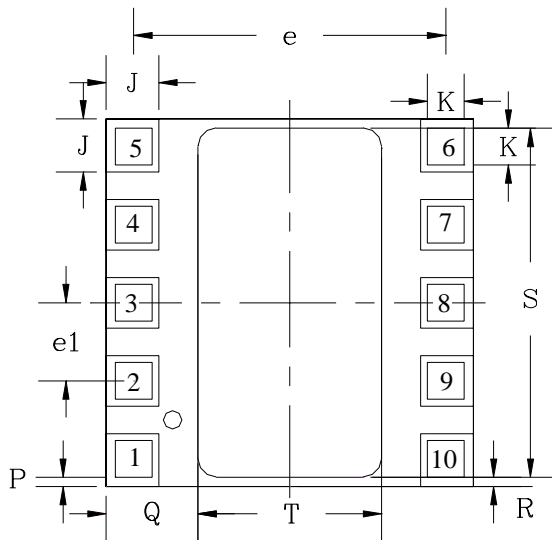

Bottom View



**Package Type: 10 Pin Plastic Module Package (cont'd)**

DESIGNATION	DESCRIPTION	DIMENSION
A	OVERALL HEIGHT	1.06 +/-0.09 mm
D	PACKAGE LENGTH	4.0 +/-0.1 mm
E	PACKAGE WIDTH	4.0 +/-0.1 mm
J	SOLDER MASK OPENING LENGTH AND WIDTH	0.575 +/-0.075 mm
K	METAL PAD LENGTH AND WIDTH	0.40 +/-0.05 mm
P	DISTANCE BETWEEN METAL PAD AND PACKAGE EDGE	0.10 +/-0.025 mm
T	GND SOLDER MASK OPENING WIDTH	2.00 +/-0.05 mm
S	GND SOLDER MASK OPENING LENGTH	3.80 +/-0.05 mm
R	DISTANCE BETWEEN GND SOLDER MASK OPENING AND PACKAGE EDGE	0.10 +/-0.1 mm
Q	DISTANCE BETWEEN GND SOLDER MASK OPENING AND PACKAGE EDGE	1.00 +/-0.1 mm
e	TERMINAL PITCH FOR TERMINAL 1-10, 2-9, 3-8, 4-7 AND 5-6	3.400 mm
e1	TERMINAL PITCH FOR TERMINAL 1-2-3-4-5 AND 6-7-8-9-10	0.850 mm

Notes:

**1. GND SOLDER MASK OPENING IS NOT CENTERED ON THE PACKAGE**

**Additional Information**

For latest specifications, additional product information, worldwide sales and distribution locations, and information about TriQuint:

Web: [www.triquint.com](http://www.triquint.com)      Tel: (503) 615-9000  
 Email: [info\\_wireless@tqs.com](mailto:info_wireless@tqs.com)      Fax: (503) 615-8902

For technical questions and additional information on specific applications:

Email: [info\\_wireless@tqs.com](mailto:info_wireless@tqs.com)

The information provided herein is believed to be reliable; TriQuint assumes no liability for inaccuracies or omissions. TriQuint assumes no responsibility for the use of this information, and all such information shall be entirely at the user's own risk. Prices and specifications are subject to change without notice. No patent rights or licenses to any of the circuits described herein are implied or granted to any third party.

TriQuint does not authorize or warrant any TriQuint product for use in life-support devices and/or systems.

Copyright © 2002 TriQuint Semiconductor, Inc. All rights reserved.

Revision 0.4, September 24, 2002



For additional information and latest specifications, see our website: [www.triquint.com](http://www.triquint.com)