

Buffered H-Bridge

Features

- 1.0-A H-Bridge
- 200-kHz Switching Rate
- Shoot-Through Limited
- TTL Compatible Inputs
- 3.8- to 13.2-V Operating Range
- Surface Mount Packaging

Applications

- VCM Driver
- Brushed Motor Driver
- Stepper Motor Driver
- Power Converter
- Optical Disk Drives
- Power Supplies
- High Performance Servo

Description

The Si9986CY is an integrated, buffered H-bridge with TTL compatible inputs and the capability of delivering a continuous 1.0 A @ $V_{DD} = 12\text{ V}$ (room temperature) at switching rates up to 200 kHz. Internal logic prevents the upper and lower outputs of either half-bridge from being turned on simultaneously. Unique input codes allow both

outputs to be forced low (for braking) or forced to a high impedance level.

The Si9986CY is available in an 8-Pin SOIC package, specified to operate over a voltage range of 3.8 V to 13.2 V and a temperature range of 0 to 70°C.

Functional Block Diagram, Pin Configuration and Truth Table

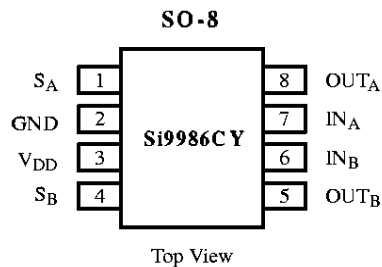

Truth Table

IN _A	IN _B	OUT _A	OUT _B
1	0	1	0
0	1	0	1
0	0	0	0
1	1	HiZ	HiZ

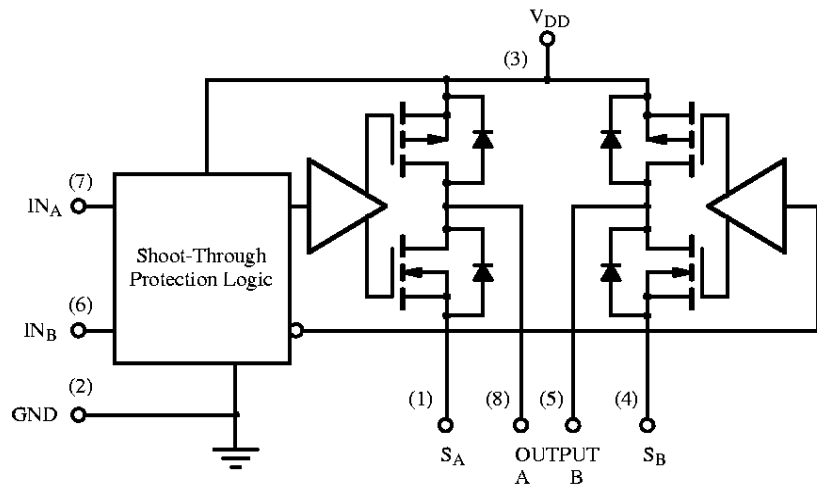

Updates to this data sheet may be obtained via facsimile by calling Siliconix FaxBack, 1-408-970-5600. Please request FaxBack document #70007.

Absolute Maximum Ratings^a

Voltage on any pin with respect to ground -0.3 V to $V_{DD}+0.3$ V
 Voltage on pins 5, 8 with respect to GND -1 V to $V_{DD}+1$ V
 Voltage on pins 1, 4 -0.3 V to GND+1 V
 Peak Output Current 1.5 A
 Storage Temperature -50 to 150°C
 Maximum Junction Temperature (T_J) 150°C

Maximum V_{DD} 15 V
 Power Dissipation^b 1 W
 θ_{JA} 100°C/W

Notes

- a. Device mounted with all leads soldered or welded to PC board.
 b. Derate 10 mW/°C above 25°C.

Recommended Operating Range

V_{DD} 3.8 V to 13.2 V
 Maximum Junction Temperature 125°C
 Operating Temperature Range (T_A) 0 to 70°C

Specifications

Parameter	Symbol	Test Conditions Unless Otherwise Specified $V_{DD} = 3.8$ to 13.2 V $S_A @ GND, S_B @ GND$	Limits C Suffix, 0 to 70°C			Unit	
			Min ^a	Typ NO TAG	Max ^a		
Input							
Input Voltage High	V_{INH}		2			V	
Input Voltage Low	V_{INL}				1		
Input Current with Input Voltage High	I_{INH}	$V_{IN} = 2$ V			1	μ A	
Input Current with Input Voltage Low	I_{INL}	$V_{IN} = 0$ V	-1				
Output							
Output Voltage High	V_{OUTH}	$I_{OUT} = -500$ mA	$V_{DD} = 10.8$ V	10.5	10.7	V	
			$V_{DD} = 4.5$ V	4.1	4.3		
		$I_{OUT} = -300$ mA, $V_{DD} = 3.8$ V		3.4	3.7		
Output Voltage Low	V_{OUTL}	$I_{OUT} = 500$ mA	$V_{DD} = 10.8$ V		0.2		0.3
			$V_{DD} = 4.5$ V		0.2		0.4
		$I_{OUT} = 300$ mA, $V_{DD} = 3.8$ V			0.1		0.4
Output Leakage Current High	I_{OLH}	$I_{NA} = I_{NB} \geq 2$ V, $V_{OUT} = V_{DD} = 13.2$ V	-10	0		μ A	
Output Leakage Current Low	I_{OLL}	$V_{OUT} = 0, V_{DD} = 13.2$ V		0	10		
Output V Clamp High	V_{CLH}	$I_{NA} = I_{NB} \geq 2$ V	$I_{OUT} = 100$ mA		$V_{DD}+0.7$	V	
Output V Clamp Low	V_{CLL}		$I_{OUT} = -100$ mA		-0.7		
Supply							
V_{DD} Supply Current	I_{DD}	$I_N = 100$ kHz, $V_{DD} = 5$ V		2		mA	
		$I_{NA} = I_{NB} = 4.5$ V, $V_{DD} = 5.5$ V			300	μ A	
Dynamic							
Propogation Delay Time	T_{PLH}	$V_{DD} = 5$ V		300		nS	
	T_{PHL}			100			

Notes

- a. The algebraic convention whereby the most negative value is a minimum and the most positive a maximum, is used in this data sheet.

b. Typical values are for DESIGN AID ONLY, not guaranteed nor subject to production testing.

Typical Characteristics (25 °C Unless Noted)

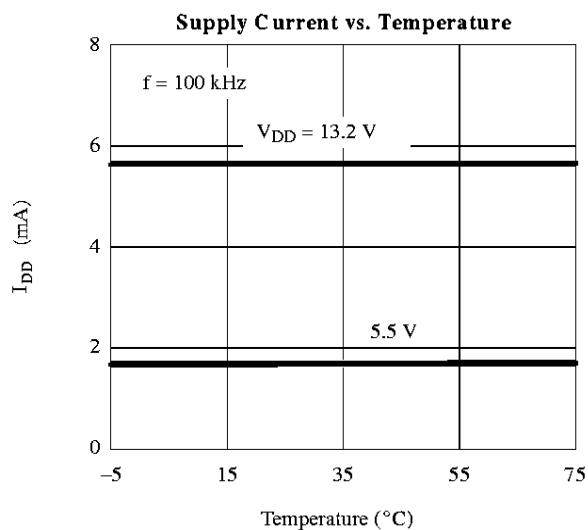
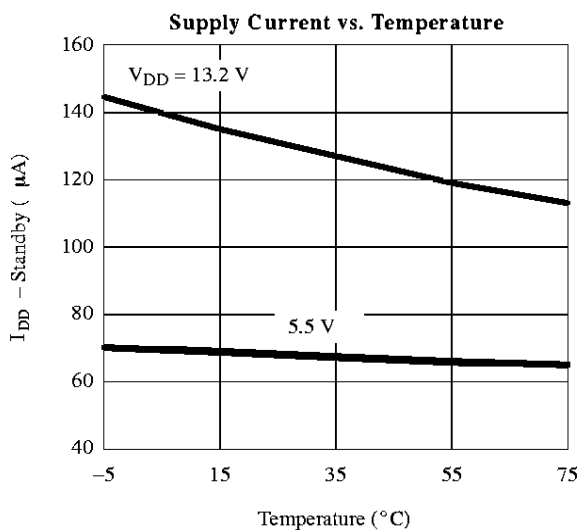
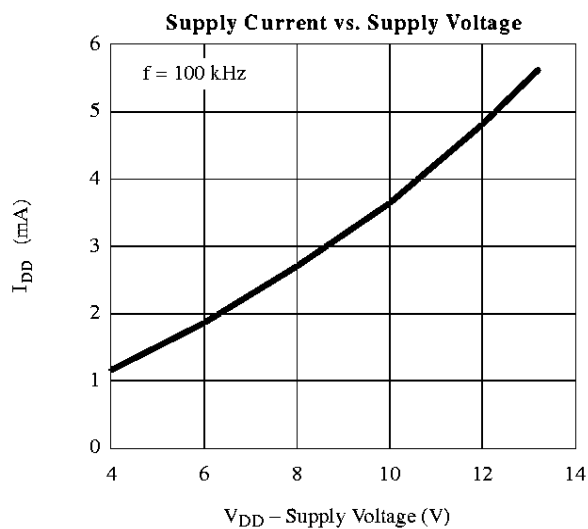
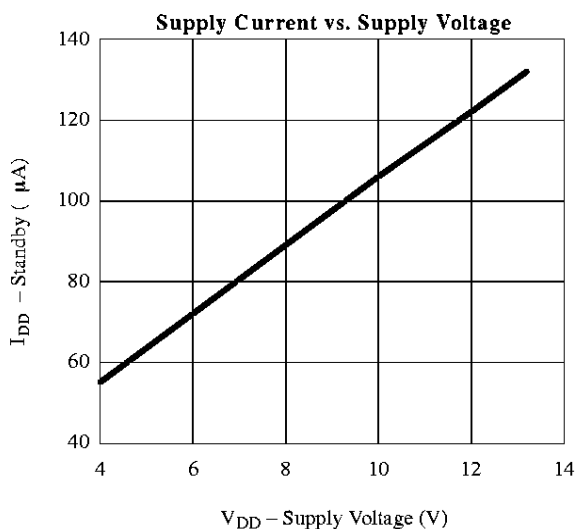
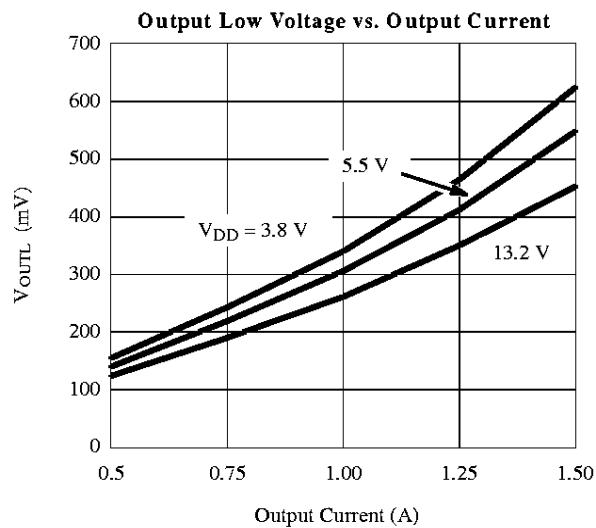
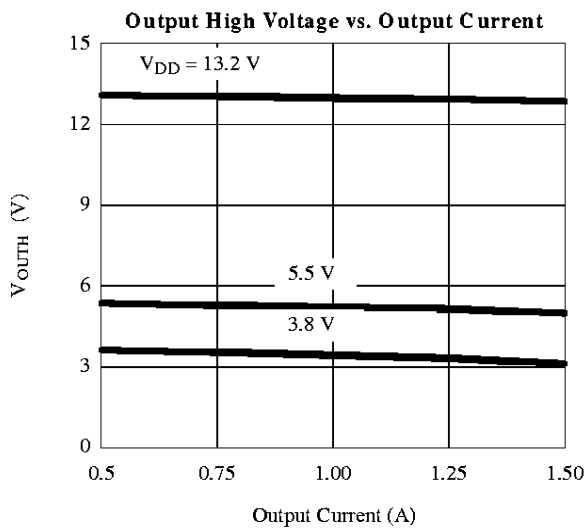

Typical Characteristics (25 °C Unless Noted)

