

---

# Single Chip Bar Code Decode IC

## Technical Data

**HBCR-1610**

**HBCR-1611**

**HBCR-1612**

---

### Features

- **Supports Five Industry Standard Bar Code Symbologies**
- **Automatic Code Recognition**
- **Choice of Parallel or Full Duplex Serial ASCII Interface**
- **Programmable via Escape Sequences or Pin Strapping**
- **CMOS**
- **Through Hole and Surface Mount Packages**
- **Audio and Visual Feedback Control**

### Description

The Single Chip Bar Code Decoder IC offers flexible bar code decoding that is designed to give OEMs the ability to address a growing number of industry segments and applications. Flexibility is made possible through firmware that allows the IC to automatically recognize and decode the most popular bar code symbologies. User implementation is easy since only a few supporting components are required.

The HBCR-1610 series decodes the most popular bar code symbologies used in applications in government, retail, industrial and medical markets. The IC

automatically discriminates and decodes the following symbologies:

- Code 39 (Standard or Extended)
- Interleaved 2 of 5
- UPC A, E0, E1
- EAN/JAN 8, 13
- Codabar
- Code 128

All bar codes may be scanned bidirectionally except for UPC/EAN/JAN bar codes with supplemental digits, which must be scanned so that the supplemental digits are scanned last.

### Scanner Input

The HBCR-1610 decode ICs are designed to accept input from hand held digital scanners and slot readers. The maximum scan speed is 30 ips (73 cm/s).

### Data Communications

The serial port supports a variety of baud rates, parity, and stop bits as described in Table 5. The IC has a "Single Read Mode" which allows the application program to stop data input until a "Next Read" command has been received. This allows the host computer to process data transmissions before enabling

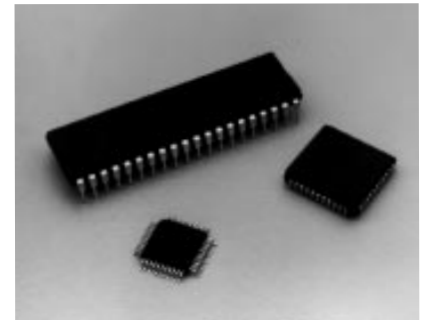

subsequent reads. Control of data transmission is available using the standard XON/XOFF ( $D_1/D_3$ ) handshake.

The parallel port is accomplished via an external 74HCT646 (octal bus transceiver) or two 74HCT574s (octal latches). There are handshake lines for both data and commands.

### Feedback Features

Both audible and visual feedback are possible with the HBCR-1610 series. In both cases, the feedback outputs from the IC should be buffered before driving the transducer. An LED or beeper connected to the IC is either controlled directly by the IC, with signals generated by successful decodes, or controlled by the host system. The tone of the beeper can be configured to one of 16 tones, or can be silenced.

## Power Requirements

The decoder IC is operated from a +5 volt DC power supply. The maximum current draw is 24 mA. The maximum power supply ripple voltage should be less than 100 mV, peak-to-peak.

## Idle Mode

The IC automatically reduces power consumption whenever there is no scanning or decoding activity, or when there is no activity on the I/O port. See Table 4.

## Manual

The HBCR-1610 Series Users Manual (HBCR-1697) covers the following topics:

- Specifications and Timing Diagrams
- Pin Definitions and Schematics
- General Scanning Tips
- Configuration and Operation
- Escape Sequence Programming
- Data Output Formats
- Sample Bar Codes
- I/O and Pacing Characteristics

## IC Configuration

The default configuration is set when the IC powers up or when a Hard Reset command is received. Default configuration of many of the options is dependent on the logic states of IC pins, as shown in Table 5. A complete description of the pins and all possible configurations is in the Users Manual. More complete and flexible configuration is achieved using escape sequence commands.

There are two pins that cause significant changes in the IC operation.

**Table 1. Recommended Operating Conditions**

Parameter	Symbol	Minimum	Maximum	Units	Notes
Supply Voltage	V <sub>CC</sub>	4.5	5.5	V	1
Ambient Temperature	T <sub>A</sub>	0	+70	°C	
Oscillator Frequency	F <sub>OSC</sub>	DC	16.000	MHz	2

**Notes:**

1. Maximum power supply ripple of 100 mV peak-to-peak.
2. The IC can use either an 11.059 or a 16.000 MHz crystal or ceramic resonator. The FRQ pin selects the frequency that matches the oscillator.

**Table 2. Absolute Maximum Ratings**

Parameter	Symbol	Minimum	Maximum	Units	Notes
Storage Temperature	T <sub>S</sub>	-55	+150	°C	
Supply Voltage	V <sub>CC</sub>	-0.5	+7.0	V	
Pin Voltage	V <sub>IN</sub>	-0.5	V <sub>CC</sub> + 0.5	V	3

**Note:**

3. Voltage on any pin with respect to ground.

**Table 3. Ordering Information**

Part Number	Description
HBCR-1610	CMOS, 40 pin DIP, bulk shipment, no manual
HBCR-1611	CMOS, 44 pin PLCC, bulk shipment, no manual
HBCR-1612	CMOS, 40 pin QFP, bulk shipment, no manual
HBCR-1697	HBCR-1610 Series Users Manual
Option A01	IC individually bagged, no manual
Option B01	IC individually boxed with manual and data sheet

### FRQ Pin

The FRQ pin is used to tell the IC what frequency oscillator is attached to the IC. Using the higher frequency allows greater maximum scan speeds, but causes the IC to draw slightly more supply current. If the state of the FRQ pin does not match the actual oscillator, beeper tones, LED flash length, parallel port timing, and serial port baud rates are adversely affected.

FRQ	Oscillator Frequency
0	16.000 MHz
1	11.059 MHz

### IOM Pin

The IOM pin selects between the serial and parallel I/O mode of the IC. Depending on the state of the IOM pin, definitions of several configuration pins change or move to new positions.

IOM	I/O Mode
0	Parallel
1	Serial

## Escape Sequences

The following set of escape sequences is used to control the IC and change its default configuration. Note that all configuration changes will be lost after a Hard Reset, or after power up. Detailed information on how to formulate and use escape sequences is given in the Users Manual.

**Table 7. Escape Sequences**

Escape Sequence	Function
EC - y <n> b	Good Read Beep Tone
EC - y <n> d	Serial Intercharacter Delay
EC E	Hard Reset
EC - y <n> f	Bar Code Symbology Selection
EC - y <n> g	Check Character Options
EC - y <n> h	Decoding Options
EC - y <n> j	Single Read Mode
EC - y <n> k	Single Read Control
EC - y <n> l	LED Control
EC - y <n> m	Interleaved 2 of 5 Length
EC - y <n> O <n characters>	Trailer Selection
EC - y <n> q	Code ID Characters
EC - y <n> s	Status Request
EC - y <n> t	Sound Tone
EC - y <n> w	Scanner Enable

**Table 4. DC Characteristics**

HBCR-1610, 1611, 1612 ( $T_A = 0^\circ\text{C}$  to  $+70^\circ\text{C}$ ,  $V_{CC} = 4.5\text{ V}$  to  $5.5\text{ V}$ ,  $V_{SS} = 0\text{ V}$ )

Symbol	Parameter	1610 Pins	1611 Pins	1612 Pins	Min.	Max.	Units	Test Conditions
$V_{IL}$	Input Low Voltage	all	all	all	-0.5	$0.2 V_{CC} - 0.1$	V	
$V_{IH}$	Input High Voltage	except 9, 19	except 10, 21	except 4, 15	$0.2 V_{CC} + 0.9$	$V_{CC} + 0.5$	V	
$V_{IH1}$	Input High Voltage	9, 19	10, 21	4, 15	$0.7 V_{CC}$	$V_{CC} + 0.5$	V	
$V_{OL}$	Output Low Voltage	1-8, 10-17, 21-28	2-9, 11, 13-19, 24-31	1-3, 5, 7-13, 18-25, 40-44		0.45	V	$I_{OL} = 1.6\text{ mA}$
$V_{OL1}$	Output Low Voltage	32-39	36-43	30-37		0.45	V	$I_{OL} = 3.2\text{ mA}$
$V_{OH}$	Output High Voltage	1-8, 10-17, 21-28	2-9, 11, 13-19, 24-31	1-3, 5, 7-13, 18-25, 40-44	2.4		V	$I_{OH} = -60\text{ }\mu\text{A}$
					$0.75 V_{CC}$		V	$I_{OH} = -25\text{ }\mu\text{A}$
					$0.9 V_{CC}$		V	$I_{OH} = -10\text{ }\mu\text{A}$
$V_{OH1}$	Output High Voltage	32-39	36-43	30-37	2.4		V	$I_{OH} = -400\text{ }\mu\text{A}$
					$0.75 V_{CC}$		V	$I_{OH} = -150\text{ }\mu\text{A}$
					$0.9 V_{CC}$		V	$I_{OH} = -40\text{ }\mu\text{A}$
$I_{IL}$	Input Low Current	1-8, 10-17, 21-28	2-9, 11, 13-19, 24-31	1-3, 5, 7-13, 18-25, 40-44		-50	$\mu\text{A}$	$V_{IN} = 0.45\text{ V}$
$I_{LI}$	Input Leakage Current	32-39	36-43	30-37		$\pm 10$	$\mu\text{A}$	$V_{SS} \leq V_{IN} \leq V_{CC}$
$R_{RST}$	Pulldown Resistor	9	10	4	20	125	K $\Omega$	
$I_{CC}$	Supply Current 11.059 MHz	40	44	38		18	mA	Scanning
						4	mA	Idle
$I_{CC}$	Supply Current 16.000 MHz	40	44	38		24	mA	Scanning
						6	mA	Idle

**Table 5. Summary of Features and Configurations – HBCR-1610 Series**

Feature	Function or Value	Default Setting	
		Serial Mode	Parallel Mode
Bar Code Symbology	When a symbology is enabled, bar codes of that type can be read, assuming other decoding options are satisfied.	Depends on pins: C39, I25, UPC CDB and C28.	All codes enabled
Interleaved 2 of 5 Label Length	Length variable from 4 to 32, or specific lengths from 2 to 32, or 6 or 14 only	Variable, 4-32	Variable, 4-32
Check Character Verification	For Code 39 For Interleaved 2 of 5 For Code 128† For UPC/EAN†	Depends on pin $\overline{C3C}$ Depends on pin $\overline{I2C}$ Enabled Enabled	Depends on pin $\overline{C3C}$ Depends on pin $\overline{I2C}$ Enabled Enabled
Check Character Transmission	For Code 39 and Interleaved 2 of 5 For UPC/EAN For Code 128†	Depends on pin $\overline{CST}$ Enabled Enabled	Depends on pin $\overline{CST}$ Enabled Enabled
Extended Code 39 Enable	Converts paired Code 39 data characters to Full ASCII characters	Depends on pin $\overline{EX3}$	Depends on pin $\overline{EX3}$
UPC/EAN Decoding Options	UPC vs. UPC/EAN UPC E expansion to UPC A UPC E Version 1 autodiscrimination UPC/EAN supplemental digits  UPC/EAN check digit UPC/EAN output format	UPC/EAN Depends on pin $\overline{UEE}$ Depends on pin $\overline{UE1}$ Depends on pins $\overline{US2}$ and $\overline{US5}$ Transmitted Standard	UPC/EAN Depends on pin $\overline{UEE}$ Depends on pin $\overline{UE1}$ Disabled  Transmitted Standard
Codabar Start/Stop Transmission	Transmits or suppresses Codabar start/stop characters	Depends on pin $\overline{CSS}$	Depends on pin $\overline{CSS}$
Baud Rates	1200, 2400, 4800, 9600	Depends on pins BR0 and BR1	–
Parity	0s, 1s, even, odd	Depends on pins PT0 and PT1	0s
Stop Bits	1 or 2	Depends on pin $\overline{STB}$	–
XON/XOFF Pacing†	Controls data flow on either port	Enabled	Enabled
Transmitted Character Delay Enable	Controls 10 millisecond intercharacter delay on the serial port	Depends on pin $\overline{ICD}$	–
Trailer Selection	String of characters appended to the decoded message (4 maximum)	$\overline{CR}$ , $\overline{CR LF}$ , $\overline{HT}$ , or none Depends on pins TR0 and TR1	$\overline{CR}$
Single Read Mode	Controls when labels can be read	Disabled	Disabled
Code ID Character Enable	Controls the transmission of the Code ID characters before decoded data	Disabled	Disabled
Good Read Beep Tone Selection	Controls the tone sounded when a bar code label is read	High or low pitch Depends on pin $\overline{GRB}$	High or low pitch Depends on pin $\overline{GRB}$
LED Control	Controls LED function: flash or turn off after a label is read	Auto Flash Mode	Auto Flash Mode

†Not configurable.

**Table 6. Summary of Commands – HBCR-1610 Series**

Feature	Description
Scanner Enable	When enabled, scans from a wand or a slot reader are decoded; otherwise, they are ignored.
Hard Reset	Resets the IC as though it were just powered up.
Self Test Failure Message	An error message is transmitted over the serial port at 9600 baud at power up if the IC self test fails.
Status Request	Returns the version number of the software.
Sound Tone	Causes the IC to sound a tone of the selected pitch for 120 milliseconds.

**Stand Alone Decoder  
(Serial Mode)**

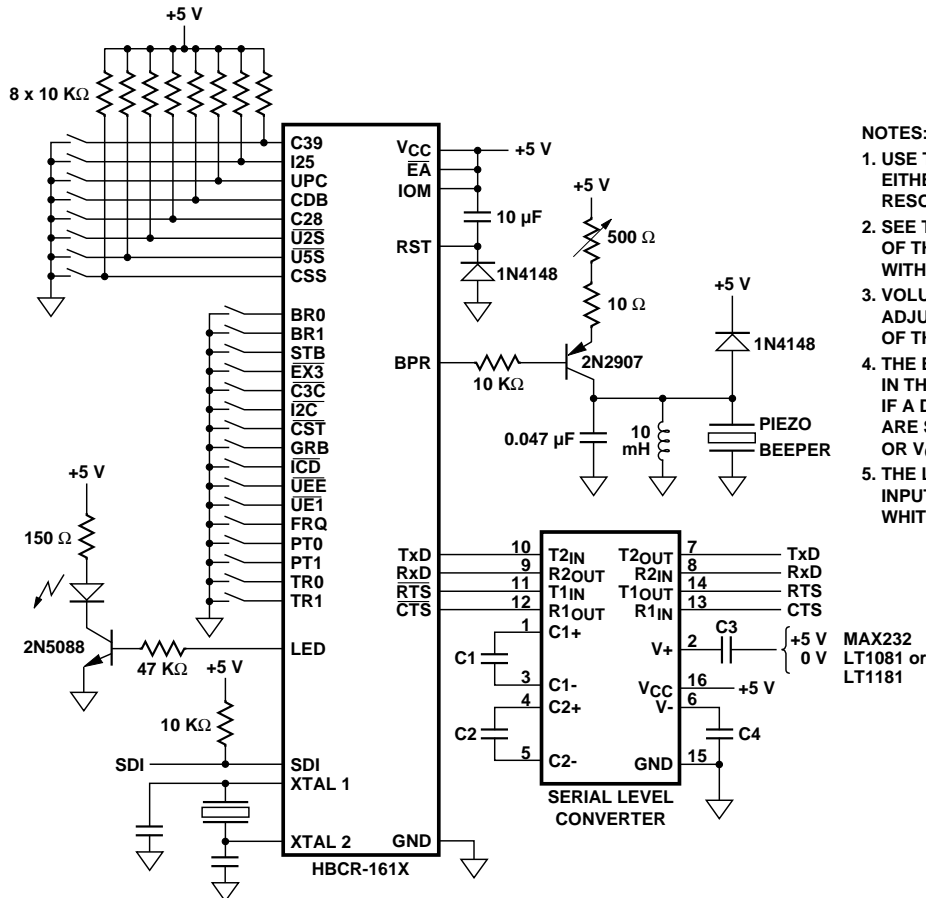

### Surface Mount IC Drying

Whenever Vapor Phase or Infra-red Reflow technologies are used to mount either of the surface mount packages, there is a possibility that previously absorbed moisture, heated very rapidly to the reflow temperatures, may cause the package to crack from internal stresses. There is a reliability concern that moisture may then enter the package over a period of time, and metal corrosion may take place, degrading the IC performance.

To reduce the amount of absorbed moisture and prevent cracking, all of the surface mount ICs should undergo one of the following baking cycles. The parts **MUST** then be mounted within 48 hours. If the parts are not mounted within 48 hours, they *must* be rebaked.

The total number of baking cycles must not exceed two (2). If the ICs are baked more than twice, Agilent cannot guarantee the performance and reliability of the parts.

Neither bake cycle can be performed in the standard shipping tubes. The ICs must be baked in an ESD safe, mechanically stable container, such as an aluminum tube or pan.

Cycle	Temperature	Time
A	125°C	24 Hours
B	60°C	96 Hours

**Note:** Cycle B must be done in an atmosphere of <5% relative humidity air or nitrogen.

### Stand Alone Decoder (Parallel Mode)

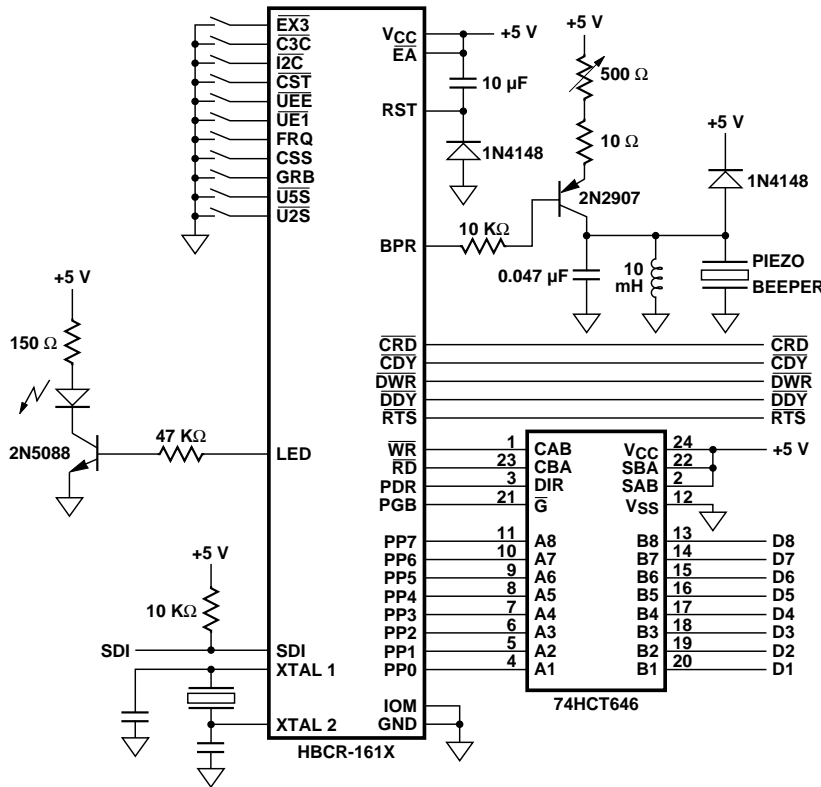

**NOTES:**

1. USE THE CORRECT CAPACITOR FOR EITHER A CRYSTAL OR A CERAMIC RESONATOR. SEE THE USERS MANUAL.
2. SEE PIN DIAGRAMS FOR THE PINOUT OF THE DECODE IC. PIN NUMBERS VARY WITH PACKAGE.
3. VOLUME OF THE BEEPER CIRCUIT IS ADJUSTABLE BY VARYING THE VALUE OF THE 500 Ω POT.
4. AN ALTERNATIVE CIRCUIT USING TWO 74HCT574 OCTAL LATCHES INSTEAD OF THE 74HCT646 IS IN THE USERS MANUAL.
5. THE LOGIC LEVELS OF THE SDI SCANNER INPUT IS AS FOLLOWS: BLACK = HIGH, WHITE = LOW.

## Parallel I/O Handshake

### COMMANDS RECEIVED BY THE IC

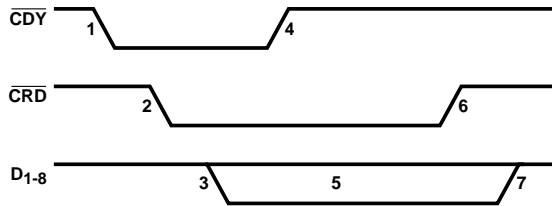

### PROTOCOL

1. THE HOST INDICATES THAT A COMMAND IS PENDING BY LOWERING  $\overline{CDY}$ .
2. THE IC INDICATES THAT IT IS READY FOR A COMMAND BY LOWERING  $\overline{CRD}$ .
3. THE HOST OUTPUTS THE COMMAND ONTO THE DATA BUS.
4. THE HOST INDICATES THAT THE DATA IS STABLE BY RAISING  $\overline{CDY}$ .
5. THE IC READS THE COMMAND FROM THE BUS.
6. THE IC INDICATES THAT THE COMMAND WAS ACCEPTED BY RAISING  $\overline{CRD}$ .
7. THE HOST REMOVES THE DATA FROM THE DATA BUS.

### DATA TRANSMITTED FROM THE IC

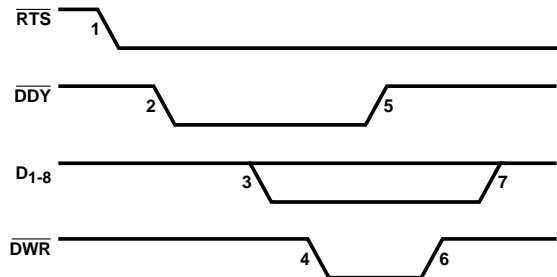

### PROTOCOL

1. THE IC INDICATES DATA IS READY TO BE TRANSMITTED BY LOWERING  $\overline{RTS}$ ;  $\overline{RTS}$  STAYS LOW UNTIL THE LAST BYTE HAS BEEN TRANSMITTED.
2. THE HOST SIGNALS THE IC THAT IT IS READY FOR DATA BY LOWERING  $\overline{DDY}$ .
3. THE IC OUTPUTS DATA ONTO THE BUS.
4. THE IC INDICATES THAT THE DATA IS STABLE BY LOWERING  $\overline{DWR}$ .
5. THE HOST ACKNOWLEDGES THAT THE DATA IS RECEIVED BY RAISING  $\overline{DDY}$ .
6. THE IC INDICATES THE END OF THE OUTPUT CYCLE BY RAISING  $\overline{DWR}$ .
7. THE IC REMOVES DATA FROM THE BUS.

## Serial Pinout

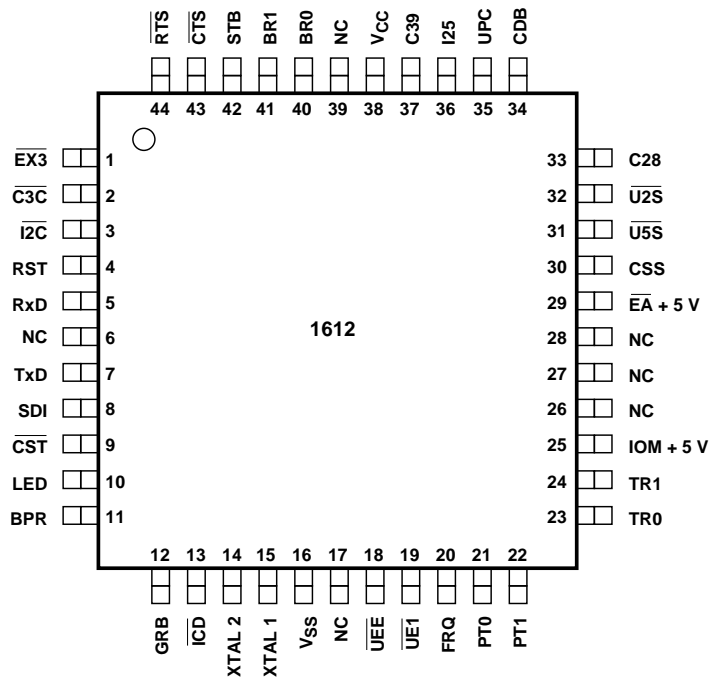
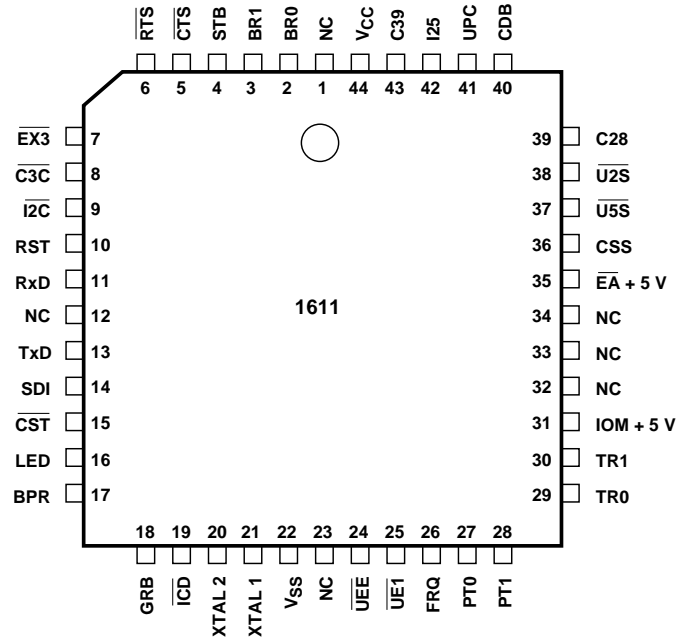
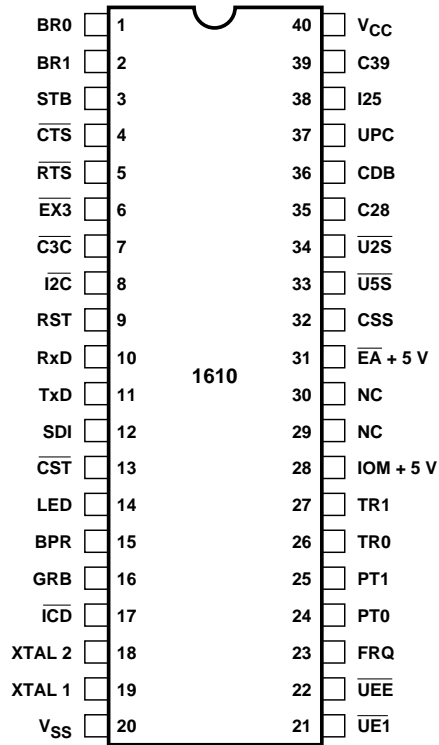

### PIN MNEMONICS

RxD	RECEIVED DATA
TxD	TRANSMITTED DATA
BR0-BR1	BAUD RATE SELECT
PT0-PT1	PARITY SELECT
TR0-TR1	TRAILER CHARACTERS SELECT
CTS	CLEAR TO SEND
RTS	REQUEST TO SEND
C39	CODE 39 ENABLE
EX3	EXTENDED CODE 39 ENABLE
I25	INTERLEAVED 2 OF 5 ENABLE
UPC	UPC/EAN ENABLE
CDB	CODABAR ENABLE
C28	CODE 128 ENABLE
UEE	UPC E EXPANSION ENABLE
UE1	UPC E VERSION 1 ENABLE
U2S	UPC 2 DIGIT SUPPLEMENTALS ENABLE
U5S	UPC 5 DIGIT SUPPLEMENTALS ENABLE
CSS	CODABAR START/STOP CHAR. ENABLE
STB	STOP BITS SELECT
C3C	CODE 39 CHECKSUM ENABLE
I2C	INTERLEAVED 2 OF 5 CHECKSUM ENABLE
CST	CHECKSUM TRANSMIT ENABLE
SDI	SCANNER DIGITAL INPUT
IOM	I/O MODE SELECT
RST	IC RESET
EA	EXTERNAL PROGRAM MEMORY ENABLE
GRB	GOOD READ BEEP TONE SELECT
FRQ	OSCILLATOR FREQUENCY SELECT
LED	LED CONTROL LINE
BPR	BEEPER CONTROL LINE
ICD	INTERCHARACTER DELAY ENABLE
XTAL1	OSCILLATOR INPUT
XTAL2	OSCILLATOR INPUT
VCC	POWER
VSS	GROUND

### Parallel Pinout

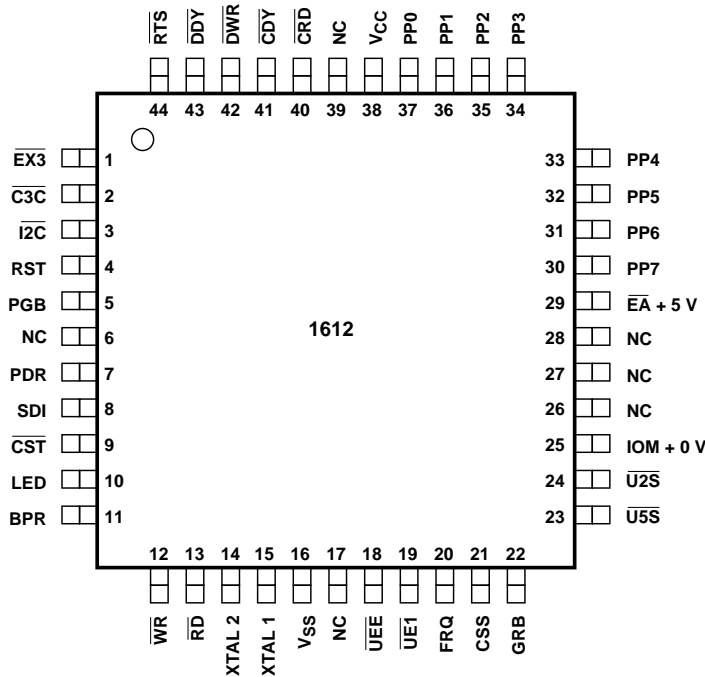
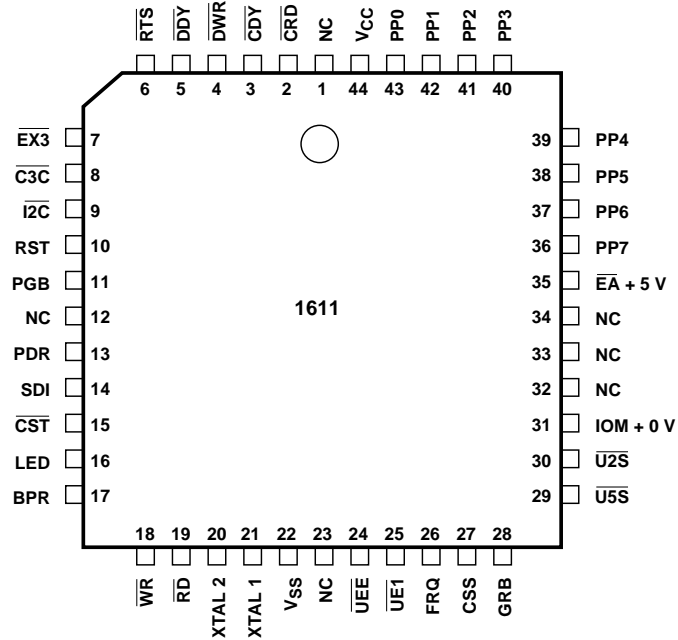
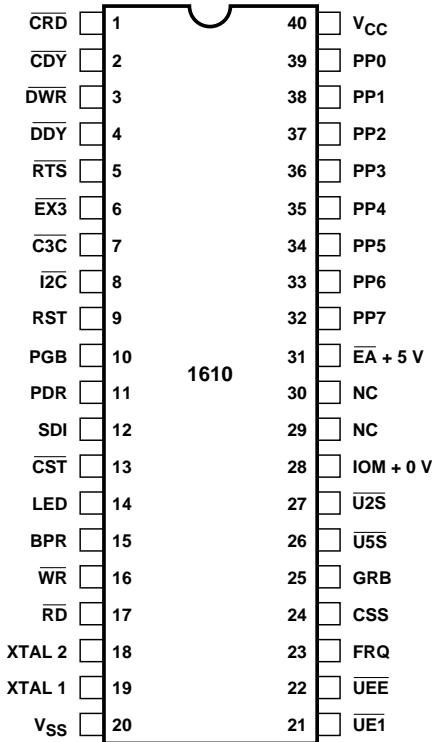

PIN MNEMONICS	
PP0-PP7	PARALLEL DATA TO INTERFACE CHIP
DWR	DATA WRITE HANDSHAKE
DDY	READY FOR DATA HANDSHAKE
CRD	COMMAND READ HANDSHAKE
CDY	COMMAND READY HANDSHAKE
RTS	REQUEST TO SEND
C3C	CODE 39 CHECKSUM ENABLE
I2C	INTERLEAVED 2 OF 5 CHECKSUM ENABLE
CST	CHECKSUM TRANSMIT ENABLE
EX3	EXTENDED CODE 39 ENABLE
WR	DATA WRITE
RD	DATA READ
U2S	UPC 2 DIGIT SUPPLEMENTALS ENABLE
U5S	UPC 5 DIGIT SUPPLEMENTALS ENABLE
CSS	CODABAR START/STOP CHAR. ENABLE
PGB	TRANSCEIVER DRIVE ENABLE
PDR	TRANSCEIVER DIRECTION CONTROL
UEE	UPC E EXPANSION ENABLE
UE1	UPC E VERSION 1 ENABLE
SDI	SCANNER DIGITAL INPUT
IOM	I/O MODE SELECT
RST	IC RESET
EA	EXTERNAL PROGRAM MEMORY ENABLE
FRQ	OSCILLATOR FREQUENCY SELECT
GRB	GOOD READ BEEP TONE SELECT
LED	LED CONTROL LINE
BPR	BEEPER CONTROL LINE
XTAL1	OSCILLATOR INPUT
XTAL2	OSCILLATOR INPUT
VCC	POWER
VSS	GROUND

### Mechanical Specifications – Units (mm)

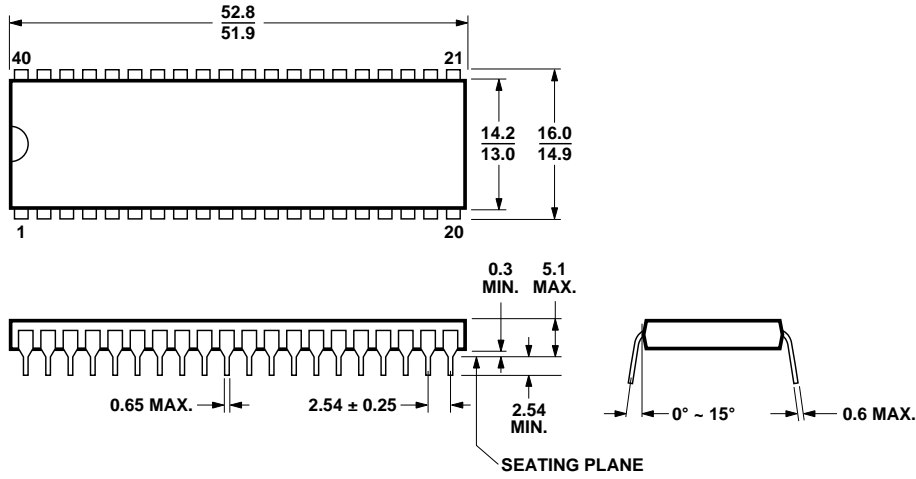

HBCR-1610

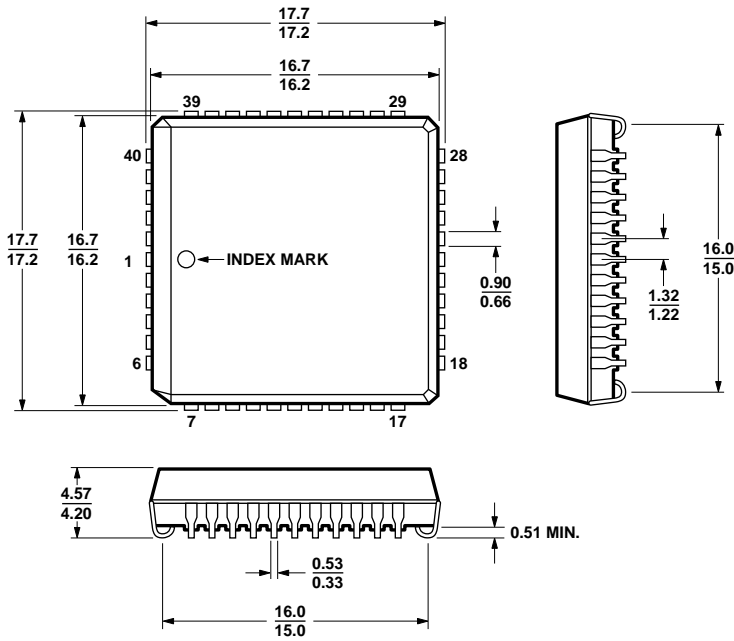

HBCR-1611

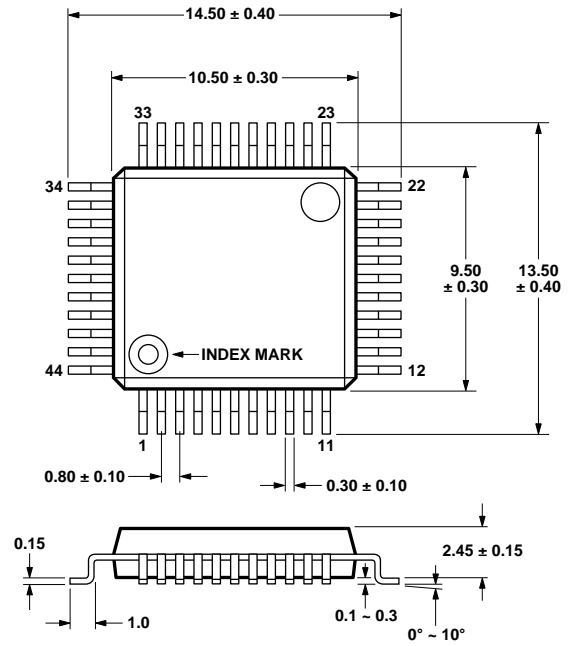

HBCR-1612



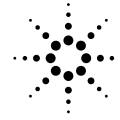

**Agilent Technologies**  
Innovating the HP Way

*[www.semiconductor.agilent.com](http://www.semiconductor.agilent.com)*

Data subject to change.

Copyright © 1999 Agilent Technologies Inc.

Obsoletes 5965-5950E

5968-2201E (11/99)