

W91530N SERIES



13-MEMORY TONE/PULSE DIALER WITH SAVE, KEYTONE, LOCK, AND HANDFREE FUNCTIONS

GENERAL DESCRIPTION

The W91530N series are tone/pulse switchable telephone dialers with 13 memories, keytone or lock, and handfree dialing control. These chips are fabricated using Winbond's high-performance CMOS technology and thus offer good performance in low-voltage, low-power operations.

FEATURES

- DTMF/pulse switchable dialer
- Two by 32 digits redial and save memory
- Three by 16 digits one-touch direct repertory memory
- Ten by 16 digits two-touch indirect repertory memory
- Pulse-to-tone (*T) keypad for long distance call operation
- Cascaded dialing
- Uses 5 × 5 keyboard
- Easy operation with redial, flash, pause, and *T keypads
- Pause, P→T (pulse-to-tone) can be stored as a digit in memory
- 0 or 9 dialing inhibition pin for PABX system or long distance dialing lock out
- Dialing rate (10 ppS or 20 ppS) selectable by bonding option
- Minimum tone output duration: 93 mS (W91534AN: 87 mS)
- Minimum intertone pause: 93 mS (W91534AN: 87 mS)
- Pause time: 3.6 sec.
- 300 mS off-hook delay in lock mode (\overline{DP} remains low for 300 mS while off hook)
- Flash break time (73 mS, 100 mS, 300 mS, or 600 mS) selectable by keypad; pause time is 1.0 mS
- Make/break ratio (2:3 or 1:2) selectable by MODE pin
- Key tone output for valid keypad entry recognition
- On-chip power-on reset
- Uses 3.579545 MHz crystal or ceramic resonator
- 18 or 20-pin dual-in-line plastic package
- The different dialers in the W91530N series are shown in the following table:

TYPE NO.	REPLACEMENT TYPE NO.	PULSE (ppS)	FLASH (mS)	M/B	KEY TONE	HANDFREE DIALING	LOCK	PACKAGE (PINS)
W91530N	W91530	10	600/300/73/100	Pin	Yes	-	-	18
	W91531							
W91530AN	W91530A	10	600/300/73/100	Pin	Yes	Yes	-	20
	W91531A							
W91531LN	W91531L	10	600/300/73/100	Pin	-	-	Yes	18
W91531ALN	W91531AL	10	600/300/73/100	Pin	-	Yes	Yes	20
W91532N	W91532	20	600/300/73/100	Pin	Yes	-	-	18
W91532AN	W91532A	20	600/300/73/100	Pin	Yes	Yes	-	20
W91534AN	New type	10	600/300/73/100	Pin	Yes	Yes	-	20

Note: The W91534AN is for use in France only. In this version, the pause time is not be added in pulse-to-tone function mode.

Publication Release Date: April 18, 2005

Revision A5

PIN CONFIGURATIONS

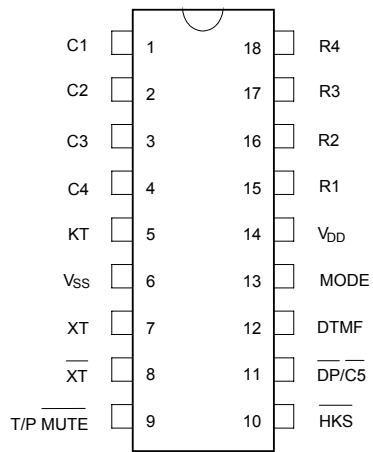

W91530N

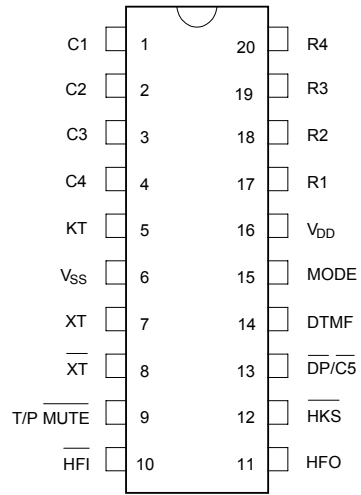

W91530AN/532AN/534AN

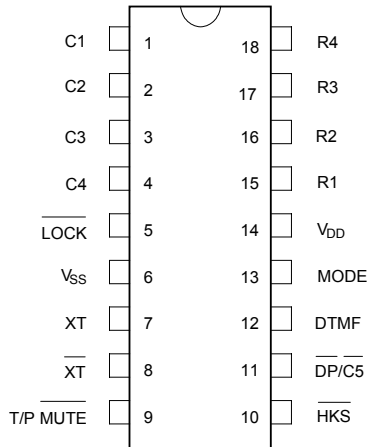

W91531LN

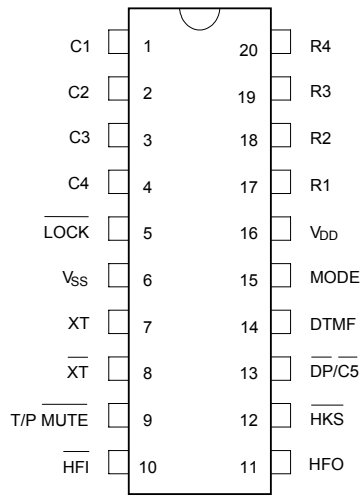

W91531ALN

W91530N SERIES



PIN DESCRIPTION

SYMBOL	18-PIN	20-PIN	I/O	FUNCTION
Column-Row Inputs	1-4 & 15-18	1-4 & 17-20	I	The keyboard input is compatible with a standard 5 x 5 keyboard, an inexpensive single contact (Form A) keyboard, and electronic input. In normal operation, any single button can be pushed to produce dual tone, pulses, or functions. Activation of two or more buttons will result in no response except for single tone.
XT	7	7	I	A built-in inverter provides oscillation with an inexpensive 3.579545 MHz crystal. The oscillator ceases when a keypad input is not sensed. The crystal frequency deviation is 0.02%.
$\overline{\text{XT}}$	8	8	O	Crystal oscillator output pin.
T/P $\overline{\text{MUTE}}$	9	9	O	The T/P $\overline{\text{MUTE}}$ is a conventional CMOS N-channel open drain output. The output transistor is switched on low level during dialing sequence (both pulse and tone mode). Otherwise, it is switched off.
MODE	13	15	I	Pulling mode pin to Vss places dialer in tone mode. Pulling mode pin to VDD places dialer in pulse mode (10 ppS) with M/B ratio of 40:60 (W91532/532AN is 20 ppS). Leaving mode pin floating places dialer in pulse mode (10 ppS) with M/B ratio of 33.3:66.7 (W91532/532AN is 20 ppS).
$\overline{\text{HKS}}$	10	12	I	The $\overline{\text{HKS}}$ (hook switch) input is used to sense whether the handset is on-hook or off-hook. In on-hook state, $\overline{\text{HKS}} = 1$: chip is in sleeping mode, no operation. In off-hook state, $\overline{\text{HKS}} = 0$: chip is enabled for normal operation. $\overline{\text{HKS}}$ pin is pulled to VDD by internal resistor.
KT	5 (except W91531LN)	5 (except W91531ALN)	O	The key tone output is a conventional CMOS inverter. The key tone is generated when any valid key is pressed; the KT pin generates a 1.2 KHz square wave at 35 mS. When no key is pressed, the KT pin remains in low state.

W91530N SERIES



Pin Description, continued

SYMBOL	18-PIN	20-PIN	I/O	FUNCTION																																				
$\overline{\text{LOCK}}$	5 (only for W91531LN)	5 (only for W91531ALN)	I	<p>The function of this terminal is to prevent "0" dialing and "9" dialing under PABX system long distance call control. When the first key input after reset is 0 or 9, all key inputs, including the 0 or 9 key, become invalid and the chip generates no output. The telephone is reinitialized by a reset.</p> <p>The function of the $\overline{\text{LOCK}}$ pin is shown below:</p> <table border="1"> <thead> <tr> <th>$\overline{\text{LOCK}}$ PIN</th> <th>FUNCTION</th> </tr> </thead> <tbody> <tr> <td>V_{DD}</td> <td>"0", "9" dialing inhibited</td> </tr> <tr> <td>Floating</td> <td>Normal dialing mode</td> </tr> <tr> <td>V_{SS}</td> <td>"0" dialing inhibited</td> </tr> </tbody> </table>	$\overline{\text{LOCK}}$ PIN	FUNCTION	V _{DD}	"0", "9" dialing inhibited	Floating	Normal dialing mode	V _{SS}	"0" dialing inhibited																												
$\overline{\text{LOCK}}$ PIN	FUNCTION																																							
V _{DD}	"0", "9" dialing inhibited																																							
Floating	Normal dialing mode																																							
V _{SS}	"0" dialing inhibited																																							
$\overline{\text{DP}}/\overline{\text{C5}}$	11	13	O	<p>N-channel open drain dialing pulse output. Flash key will cause $\overline{\text{DP}}$ to be active in either tone mode or pulse mode.</p> <p>In lock mode, the $\overline{\text{DP}}$ remains low for 300 mS during off-hook delay time.</p> <p>The timing diagram for pulse mode is shown in Figure 1(a, b, c, d).</p>																																				
DTMF	12	14	O	<p>During pulse dialing, this pin remains in low state regardless of keypad input. In tone mode, it will output a dual or single tone.</p> <p>A detailed timing diagram for tone mode is shown in Figure 2(a, b, c, d).</p> <table border="1"> <thead> <tr> <th colspan="4">OUTPUT FREQUENCY</th> </tr> <tr> <th></th> <th>Specified</th> <th>Actual</th> <th>Error %</th> </tr> </thead> <tbody> <tr> <td>R1</td> <td>697</td> <td>699</td> <td>+0.28</td> </tr> <tr> <td>R2</td> <td>770</td> <td>766</td> <td>-0.52</td> </tr> <tr> <td>R3</td> <td>852</td> <td>848</td> <td>-0.47</td> </tr> <tr> <td>R4</td> <td>941</td> <td>948</td> <td>+0.74</td> </tr> <tr> <td>C1</td> <td>1209</td> <td>1216</td> <td>+0.57</td> </tr> <tr> <td>C2</td> <td>1336</td> <td>1332</td> <td>-0.30</td> </tr> <tr> <td>C3</td> <td>1477</td> <td>1472</td> <td>-0.34</td> </tr> </tbody> </table>	OUTPUT FREQUENCY					Specified	Actual	Error %	R1	697	699	+0.28	R2	770	766	-0.52	R3	852	848	-0.47	R4	941	948	+0.74	C1	1209	1216	+0.57	C2	1336	1332	-0.30	C3	1477	1472	-0.34
OUTPUT FREQUENCY																																								
	Specified	Actual	Error %																																					
R1	697	699	+0.28																																					
R2	770	766	-0.52																																					
R3	852	848	-0.47																																					
R4	941	948	+0.74																																					
C1	1209	1216	+0.57																																					
C2	1336	1332	-0.30																																					
C3	1477	1472	-0.34																																					
V _{DD} , V _{SS}	14, 6	16, 6	I	<p>Power input pins for the dialer chip. V_{DD} is the main power and V_{SS} is the ground.</p>																																				

W91530N SERIES



Pin Description, continued

SYMBOL	18-PIN	20-PIN	I/O	FUNCTION																																								
$\overline{\text{HFI}}$, HFO	-	10, 11	I, O	<p>Handfree control pins.</p> <p>A low pulse on the $\overline{\text{HFI}}$ input pin toggles the handfree control state.</p> <p>Status of the handfree control state is listed in the following table:</p> <table border="1"> <thead> <tr> <th colspan="2">CURRENT STATE</th> <th colspan="3">NEXT STATE</th> </tr> <tr> <th>HOOK SW.</th> <th>HFO</th> <th>INPUT</th> <th>HFO</th> <th>DIALING</th> </tr> </thead> <tbody> <tr> <td>-</td> <td>Low</td> <td>$\overline{\text{HFI}} \downarrow$</td> <td>High</td> <td>Yes</td> </tr> <tr> <td>On Hook</td> <td>High</td> <td>$\overline{\text{HFI}} \downarrow$</td> <td>Low</td> <td>No</td> </tr> <tr> <td>Off Hook</td> <td>High</td> <td>$\overline{\text{HFI}} \downarrow$</td> <td>Low</td> <td>Yes</td> </tr> <tr> <td>On Hook</td> <td>-</td> <td>Off Hook</td> <td>Low</td> <td>Yes</td> </tr> <tr> <td>Off Hook</td> <td>Low</td> <td>On Hook</td> <td>Low</td> <td>No</td> </tr> <tr> <td>Off Hook</td> <td>High</td> <td>On Hook</td> <td>High</td> <td>Yes</td> </tr> </tbody> </table> <p>$\overline{\text{HFI}}$ pin is pulled to VDD by an internal resistor.</p> <p>Detailed timing diagram is shown in Figure 3.</p>	CURRENT STATE		NEXT STATE			HOOK SW.	HFO	INPUT	HFO	DIALING	-	Low	$\overline{\text{HFI}} \downarrow$	High	Yes	On Hook	High	$\overline{\text{HFI}} \downarrow$	Low	No	Off Hook	High	$\overline{\text{HFI}} \downarrow$	Low	Yes	On Hook	-	Off Hook	Low	Yes	Off Hook	Low	On Hook	Low	No	Off Hook	High	On Hook	High	Yes
CURRENT STATE		NEXT STATE																																										
HOOK SW.	HFO	INPUT	HFO	DIALING																																								
-	Low	$\overline{\text{HFI}} \downarrow$	High	Yes																																								
On Hook	High	$\overline{\text{HFI}} \downarrow$	Low	No																																								
Off Hook	High	$\overline{\text{HFI}} \downarrow$	Low	Yes																																								
On Hook	-	Off Hook	Low	Yes																																								
Off Hook	Low	On Hook	Low	No																																								
Off Hook	High	On Hook	High	Yes																																								

BLOCK DIAGRAM

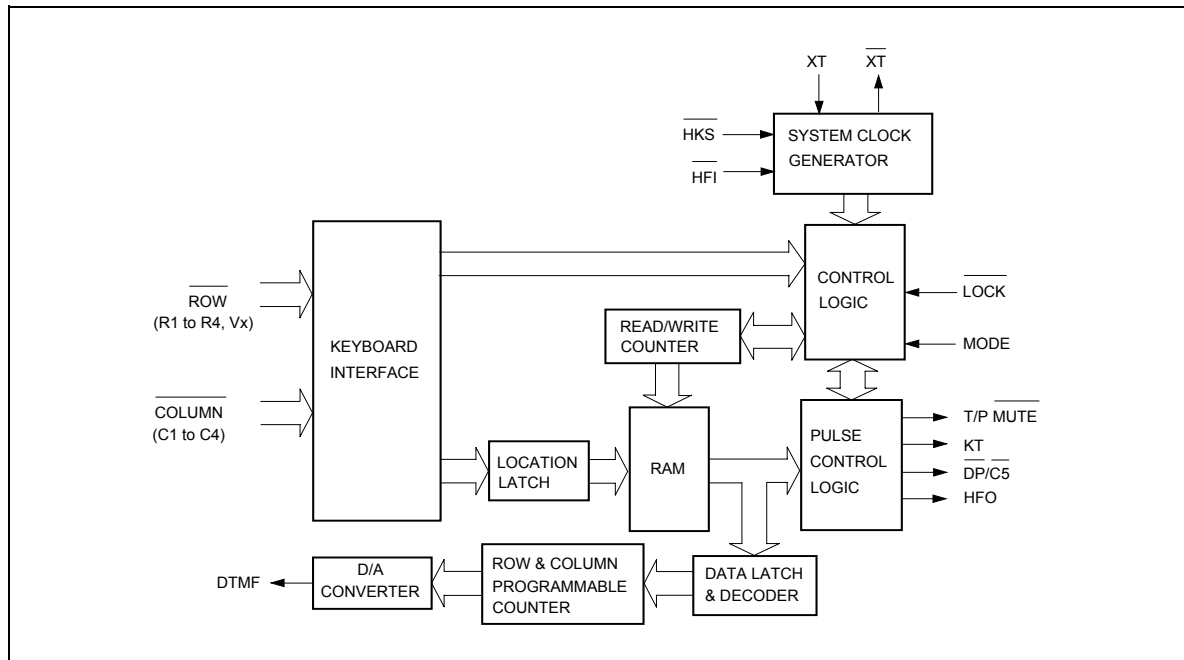

Publication Release Date: April 18, 2005



FUNCTIONAL DESCRIPTION

Keyboard Operation

C1	C2	C3	C4	$\overline{DP/C5}$	
1	2	3	S	M1	R1
4	5	6	F4	M2	R2
7	8	9	A	M3	R3
*T	0	#	R/P	SAVE	R4
F1	F2	F3			Vx

- S: Store function key
- A: Indirect repertory memory dialing function key
- R/P: Redial and pause function key
- *T: * in tone mode and P→T key in pulse mode
- SAVE: Save function key for one-touch 32-digit memory
- M1, ..., M3: One-touch memory
- F1, ..., F4: Flash function keys: F1 = 600 mS, F2 = 300 mS, F3 = 73 mS, F4 = 100 mS, and all flash pause time is 1.0 mS

Note: Mn = M1, ..., M3; Ln = 0, ..., 9, *T, #, Pause.

Normal Dialing

OFF HOOK (or ON HOOK & $\overline{HFI} \downarrow \underline{\quad}$), D1, D2, ..., Dn

1. D1, D2, ..., Dn will be dialed out.
2. Dialing length is unlimited, but redial is inhibited if length oversteps 32 digits in normal dialing.

Redialing

OFF HOOK (or ON HOOK & $\overline{HFI} \downarrow \underline{\quad}$), D1, D2, ..., Dn BUSY, Come

ON HOOK, OFF HOOK (or ON HOOK & $\overline{HFI} \downarrow \underline{\quad}$), R/P

or ON HOOK & $\overline{HFI} \downarrow \underline{\quad}$, D1, D2, ..., Dn, BUSY, $\overline{HFI} \downarrow \underline{\quad}$, Come

1. The redial memory content will be D1, D2, ..., Dn.
2. The R/P key can execute the redial function only as first key-in after off-hook; otherwise, it will execute the pause function.

W91530N SERIES



Number Store

OFF HOOK (or ON HOOK & $\overline{\text{HFI}}\downarrow$), D1 , D2 , ..., Dn , S , S , Mn (or Ln)

1. If the sequence of the dialed digits D1, D2, ..., Dn has not finished, S will be ignored.
2. D1, D2, ..., Dn will be dialed out and stored in memory location Mn (or Ln).

OFF HOOK (or ON HOOK & $\overline{\text{HFI}}\downarrow$), S , D1 , D2 , ..., Dn , S , Mn (or Ln)

3. D1, D2, ..., Dn will be stored in memory location Mn (or Ln) but will not be dialed out.
4. R/P and */T keys can be stored as a digit in memory, but R/P key cannot be the first digit. In store mode, R/P is the pause function key.
5. The store mode is released after the store function is executed or when the state of the hook switch changes or the flash function is executed.

Save

OFF HOOK (or ON HOOK & $\overline{\text{HFI}}\downarrow$), D1 , D2 , ..., Dn , SAVE

1. D1, D2, ..., Dn will be dialed out.
2. If the dialing of D1 to Dn is finished, pressing SAVE will cause D1 to Dn to be duplicated to save memory.

ON HOOK , OFF HOOK (or $\overline{\text{HFI}}\downarrow$), SAVE

3. D1 to Dn will be dialed out after SAVE key is pressed.

Repertory Dialing Procedure

OFF HOOK (or ON HOOK & $\overline{\text{HFI}}\downarrow$), Mn (or SAVE)

1. The content of memory location Mn (or save) will be dialed out.

OFF HOOK (or ON HOOK & $\overline{\text{HFI}}\downarrow$), A , Ln

2. The content of memory location Ln will be dialed out.

Access Pause

OFF HOOK (or ON HOOK & $\overline{\text{HFI}}\downarrow$), D1 , D2 , R/P , D3 , ..., Dn

1. The pause function can be stored as a digit in memory.
2. The pause function is executed in normal dialing or redialing or memory dialing.
3. The pause function timing diagram is shown in Figure 4.

W91530N SERIES



Pulse-to-tone (*T)

OFF HOOK (or ON HOOK & $\overline{\text{HFI}} \downarrow \underline{\quad}$), D1, D2, ..., Dn, */T, D1', D2', ..., Dn'

1. If the mode switch is set to pulse mode, then the output signal will be:

D1, D2, ..., Dn, Pause, D1', D2', ..., Dn'
(Pulse) (Tone)

In the case of the W91534AN, the output signal will be:

D1, D2, ..., Dn, *, D1', D2', ..., Dn'
(Pulse) (Tone)

2. If the mode switch is set to tone mode, then the output signal will be:

D1, D2, ..., Dn, *, D1', D2', ..., Dn'
(Tone) (Tone)

3. The dialer remains in tone mode when the digits have been dialed out and can be reset to pulse mode only by going on-hook.

4. The function timing diagram is shown in Figure 5.

Flash

OFF HOOK (or ON HOOK & $\overline{\text{HFI}} \downarrow \underline{\quad}$), Fn

1. Fn = F1, ..., F4.

2. If Fn is pressed, the dialer will execute a flash break time of 600 mS (F1), 300 mS (F2), 73 mS (F3), or 100 mS (F4). The pause time is 1.0 second.

3. Flash key cannot be stored as a digit in memory. The flash key has first priority among keyboard functions.

4. The system will return to the initial state after the flash pause time is finished.

5. The flash function timing diagram is shown in Figure 6.

Cascaded Dialing

OFF HOOK (or ON HOOK & $\overline{\text{HFI}} \downarrow \underline{\quad}$),

1. Normal dialing + Repertory dialing + Normal dialing
(1st sequence) (2nd sequence)

2. Repertory dialing + Normal dialing + Repertory dialing
(1st sequence) (2nd sequence)

3. Redialing + Normal dialing + Repertory dialing
(1st sequence) (2nd sequence)

• Redialing and save dialing is valid only for the first key-in.

W91530N SERIES



ABSOLUTE MAXIMUM RATINGS

PARAMETER	SYMBOL	RATING	UNIT
DC Supply Voltage	VDD-VSS	-0.3 to +7.0	V
Input/Output Voltage	VIL	VSS -0.3	V
	VIH	VDD +0.3	V
	VOL	VSS -0.3	V
	VOH	VDD +0.3	V
Power Dissipation	PD	120	mW
Operating Temperature	TOPR	-20 to +70	°C
Storage Temperature	TSTG	-55 to +150	°C

Note: Exposure to conditions beyond those listed under Absolute Maximum Ratings may adversely affect the life and reliability of the device.

DC CHARACTERISTICS

(VDD-VSS = 2.5V, Fosc. = 3.58 MHz, TA = 25° C, all outputs unloaded)

PARAMETER	SYMBOL	CONDITIONS	MIN.	TYP.	MAX.	UNIT
Operating Voltage	VDD	-	2.0	-	5.5	V
Operating Current	IOP	Tone	-	0.4	0.6	mA
		Pulse	-	0.2	0.4	mA
Standby Current	ISB	$\overline{\text{HKS}} = 0$, No load & No key entry	-	-	15	μA
Memory Retention Current	IMR	$\overline{\text{HKS}} = 1$, VDD = 1.0V	-	-	0.2	μA
Tone Output Voltage	VTO	Row group, RL = 5 KΩ	130	150	170	mVrms
Pre-emphasis		Col/Row, VDD = 2.0 to 5.5V	1	2	3	dB
DTMF Distortion	THD	RL = 5 KΩ, VDD = 2.0 to 5.5V	-	-30	-23	dB
DTMF Output DC Level	VTDC	RL = 5 KΩ, VDD = 2.0 to 5.5V	1.0	-	3.0	V

W91530N SERIES



DC Characteristics, continued

PARAMETER	SYMBOL	CONDITIONS	MIN.	TYP.	MAX.	UNIT
DTMF Output Sink Current	ITL	V _{TO} = 0.5V	0.2	-	-	mA
\overline{DP} Output Sink Current	IPL	V _{PO} = 0.5V	0.5	-	-	mA
T/P \overline{MUTE} Output Sink Current	IML	V _{MO} = 0.5V	0.5	-	-	mA
KT Drive/Sink Current	IKTH	V _{KTH} = 2.0V	0.5	-	-	mA
	IKTL	V _{KTL} = 0.5V	0.5	-	-	mA
HFO Drive/Sink Current	IHFH	V _{HFH} = 2.0V	0.5	-	-	mA
	IHFL	V _{HFL} = 0.5V	0.5	-	-	mA
Keypad Input Drive Current	IKD	V _I = 0V	4	-	-	μA
Keypad Input Sink Current	IKS	V _I = 2.5V	200	400	-	μA
Keypad Resistance		-	-	-	5.0	KΩ

AC CHARACTERISTICS

PARAMETER	SYMBOL	CONDITIONS	MIN.	TYP.	MAX.	UNIT
Key-in Debounce	TKID	-	-	20	-	mS
Key Release Debounce	TKRD	-	-	20	-	mS
On-hook Debounce	TOHD	Lock Mode	-	20	-	mS
		Unlock Mode	-	150	-	mS
Pre-digit Pause ¹	TPDP1 10 ppS	Mode Pin = VDD	-	40	-	mS
		Mode Pin = Floating	-	33.3	-	mS
Pre-digit Pause ²	TPDP2 20 ppS	Mode Pin = VDD	-	20	-	mS
		Mode Pin = Floating	-	16.7	-	mS
Interdigit Pause (Auto dialing)	TIDP	10 ppS	-	800	-	mS
		20 ppS	-	500	-	mS
Make/Break Ratio	M:B	Mode Pin = VDD	-	40:60	-	%
		Mode Pin = Floating	-	33.3:66.7	-	%

W91530N SERIES



AC Characteristics, continued

PARAMETER	SYMBOL	CONDITIONS	MIN.	TYP.	MAX.	UNIT
Tone Output Duration	TTD	Except for W91534AN	-	93	-	mS
Intertone Pause	TITP	Except for W91534AN	-	93	-	mS
Tone Output Duration	TTD	W91534AN Only	-	87	-	mS
Intertone Pause	TITP	W91534AN Only	-	87	-	mS
Flash Break Time	TFB	F1	-	600	-	mS
		F2	-	300	-	
		F3	-	73	-	
		F4	-	100	-	
Flash Pause Time	TFP		-	1.0	-	S
Pause Time	TP		-	3.6	-	S
Key Tone Frequency	FKT		-	1.2	-	KHz
Key Tone Duration	TKTD		-	35	-	mS
One-key Redialing Pause Time	TRP		-	600	-	mS
One-key Redialing Break Time	TRB		-	2.2	-	S
Off-hook Delay	TOFD	Lock Only	-	300	-	mS
First Key-in Delay	TFKP	Lock Only	-	300	-	mS

Notes:

- Crystal parameters suggested for proper operation are $R_s < 100 \Omega$, $L_m = 96 \text{ mH}$, $C_m = 0.02 \text{ pF}$, $C_n = 5 \text{ pF}$, $C_l = 18 \text{ pF}$, $F_{osc} = 3.579545 \text{ MHz} \pm 0.02\%$.
- Crystal oscillator accuracy directly affects these times.



TIMING WAVEFORMS

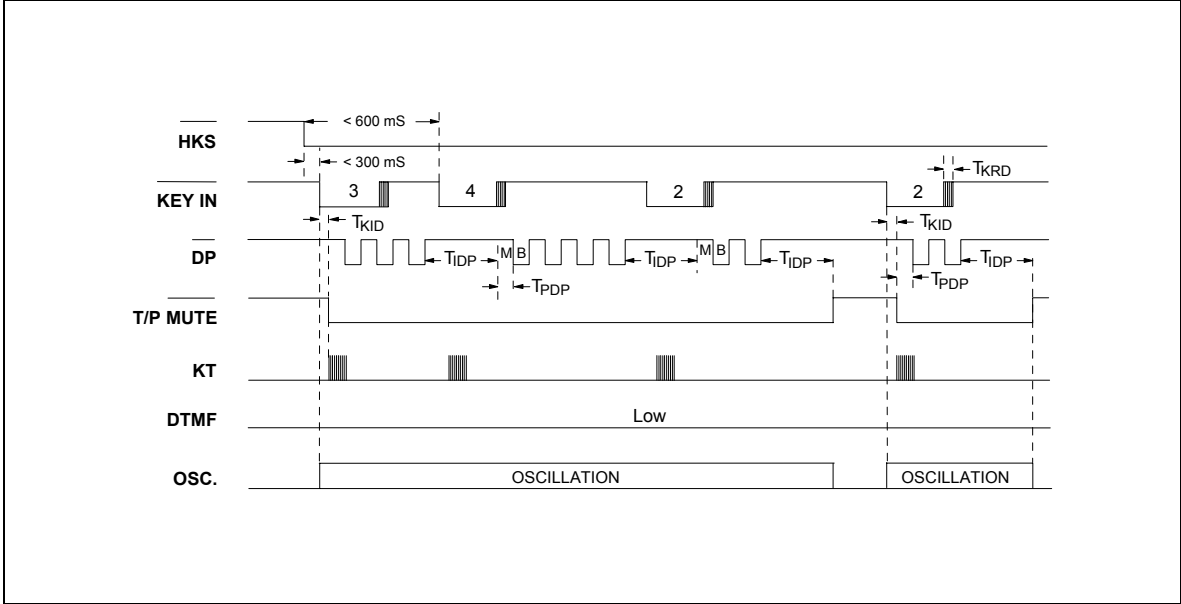

Figure 1(a). Normal Dialing Timing Diagram (Pulse Mode Without Lock Function)

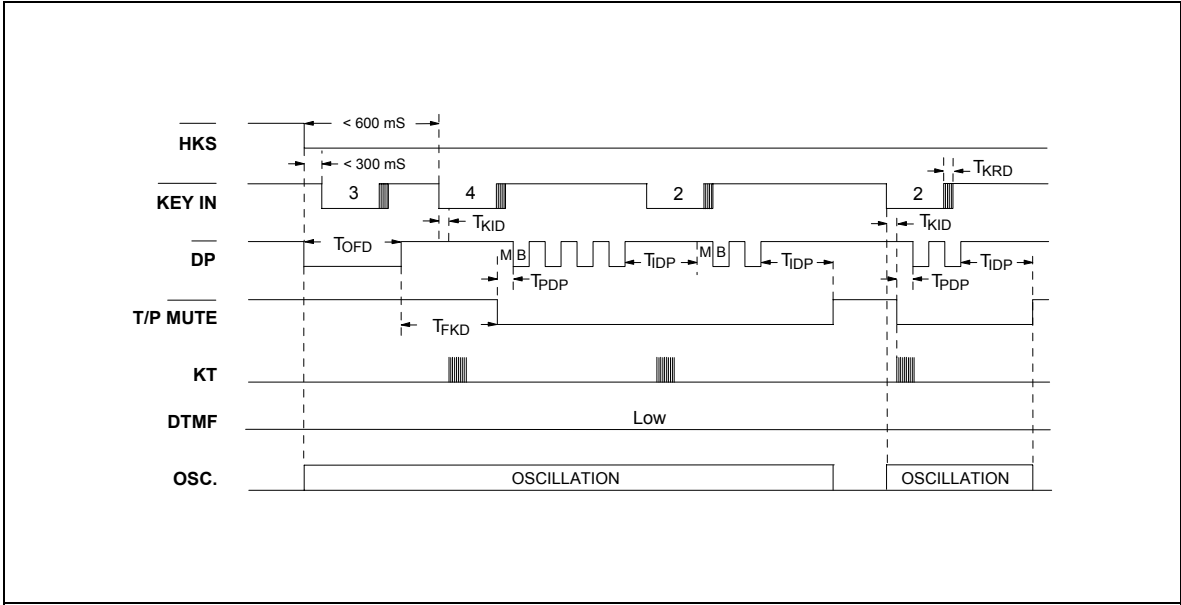

Figure 1(b). Normal Dialing Timing Diagram (Pulse Mode with Lock Function)

W91530N SERIES



Timing Waveforms, continued

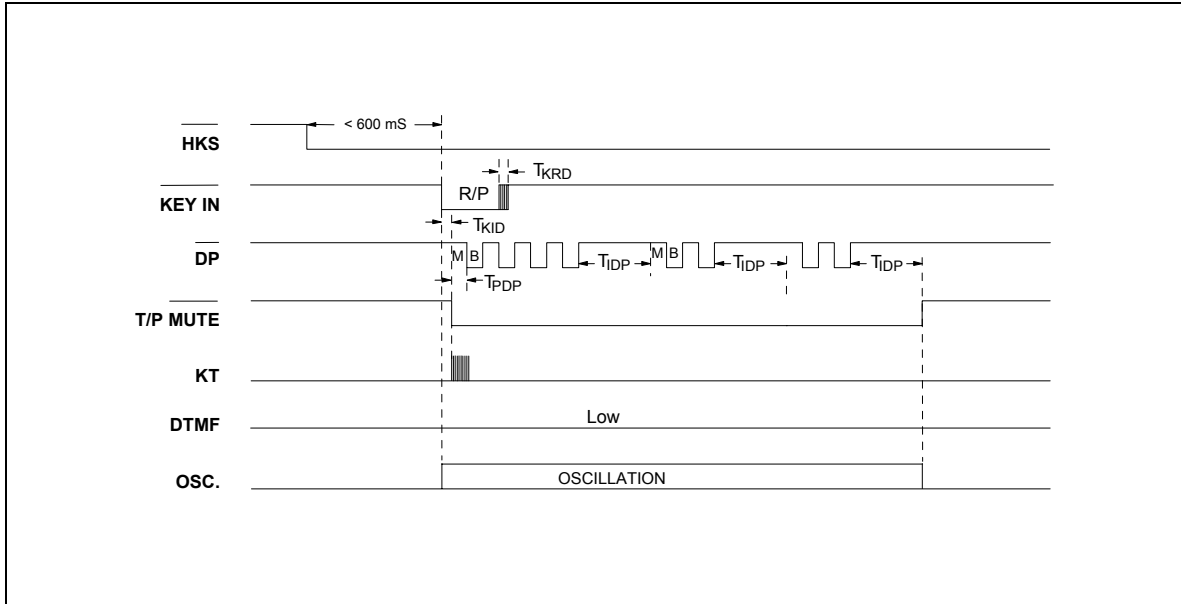

Figure 1(c). Auto Dialing Timing Diagram (Pulse Mode Without Lock Function)

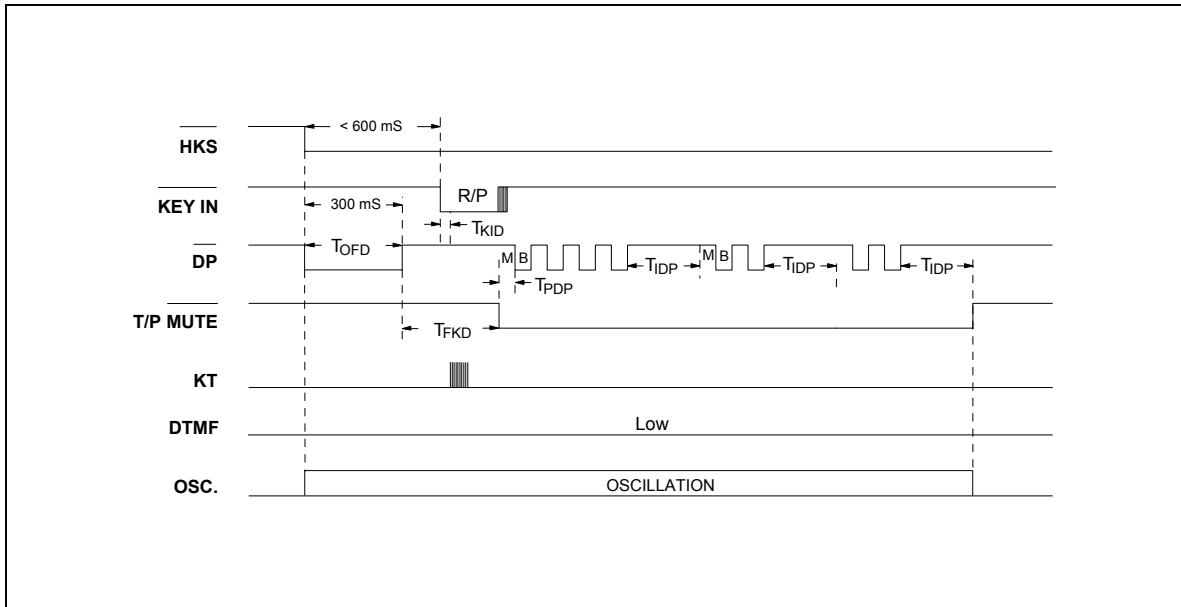

Figure 1(d). Auto Dialing Timing Diagram (Pulse Mode with Lock Function)

W91530N SERIES



Timing Waveforms, continued

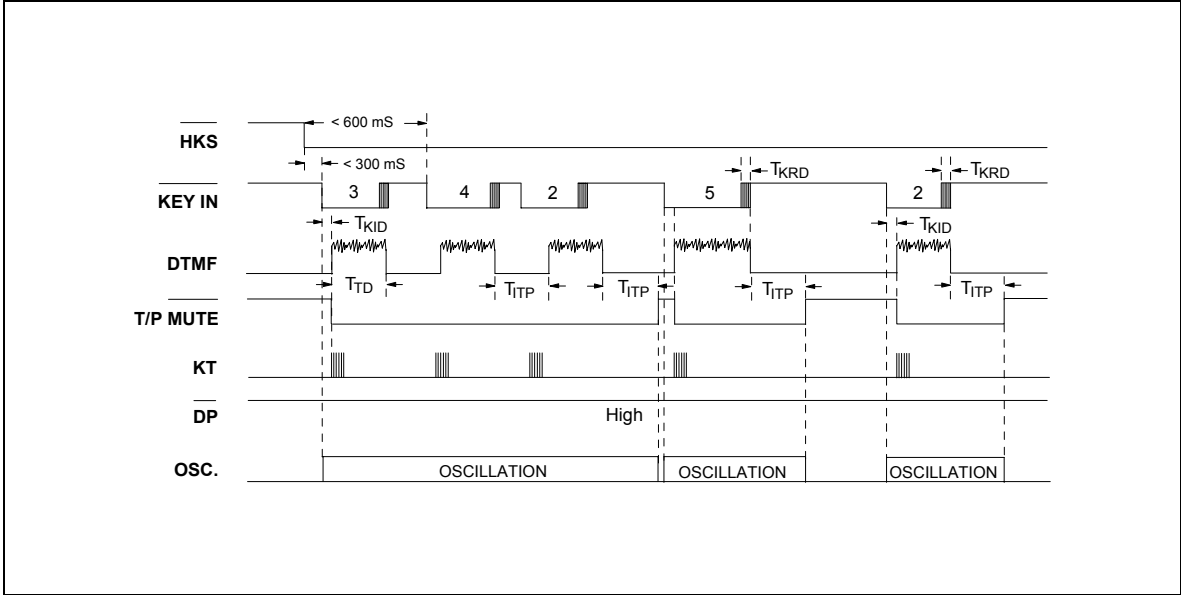

Figure 2(a). Normal Dialing Timing Diagram (Tone Mode Without Lock Function)

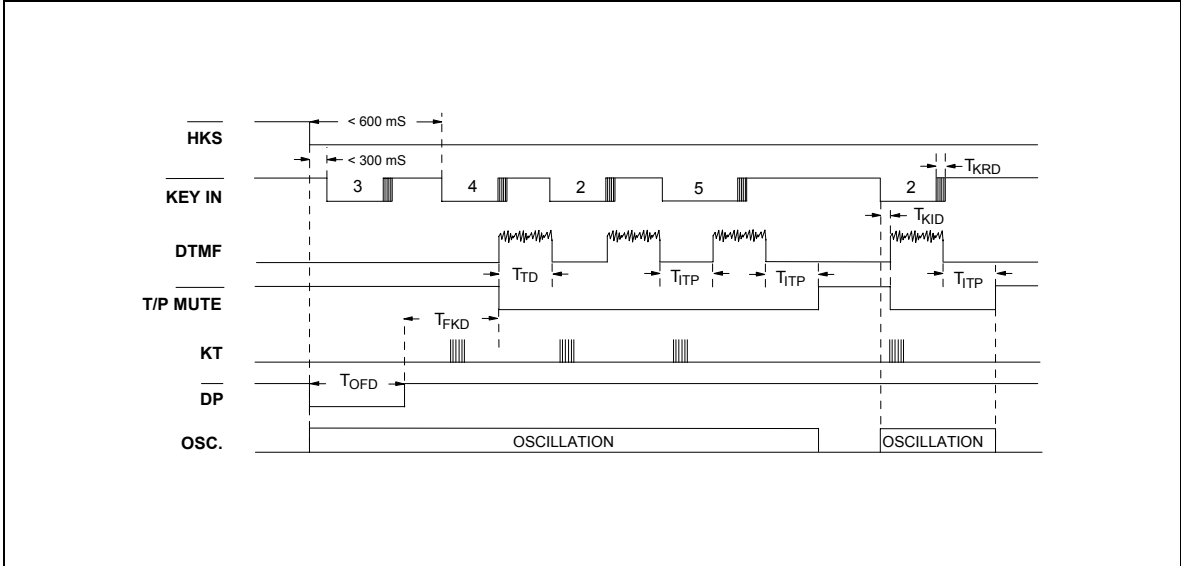

Figure 2(b). Normal Dialing Timing Diagram (Tone Mode with Lock Function)

W91530N SERIES



Timing Waveforms, continued

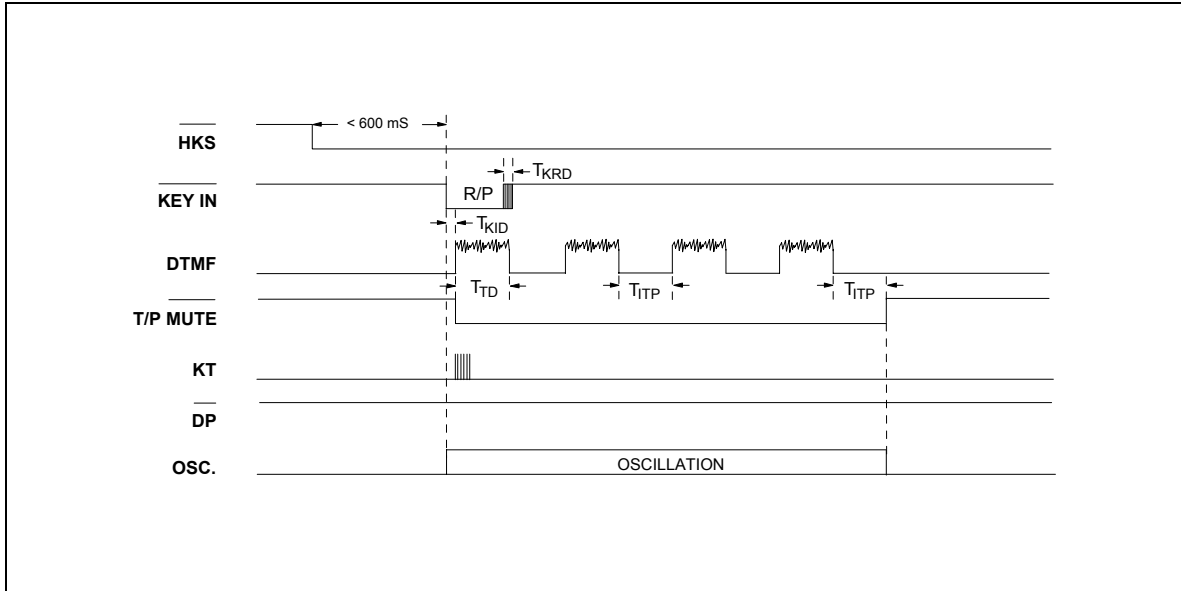

Figure 2(c). Auto Dialing Timing Diagram (Tone Mode Without Lock Function)

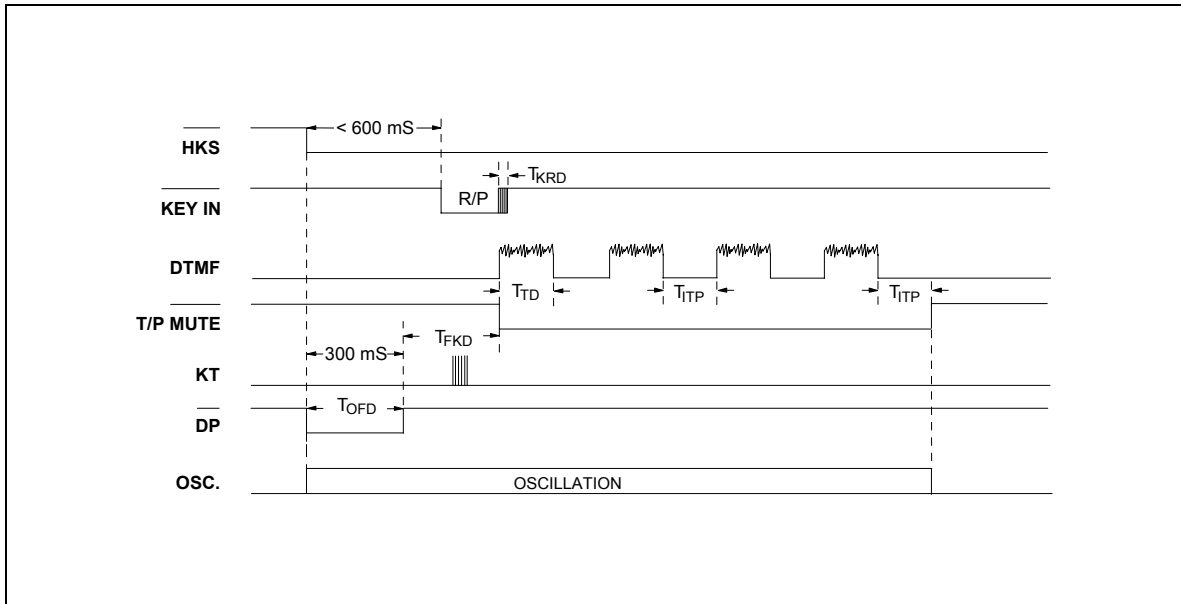

Figure 2(d) Auto Dialing Timing Diagram (Tone Mode with Lock Function)

W91530N SERIES



Timing Waveforms, continued

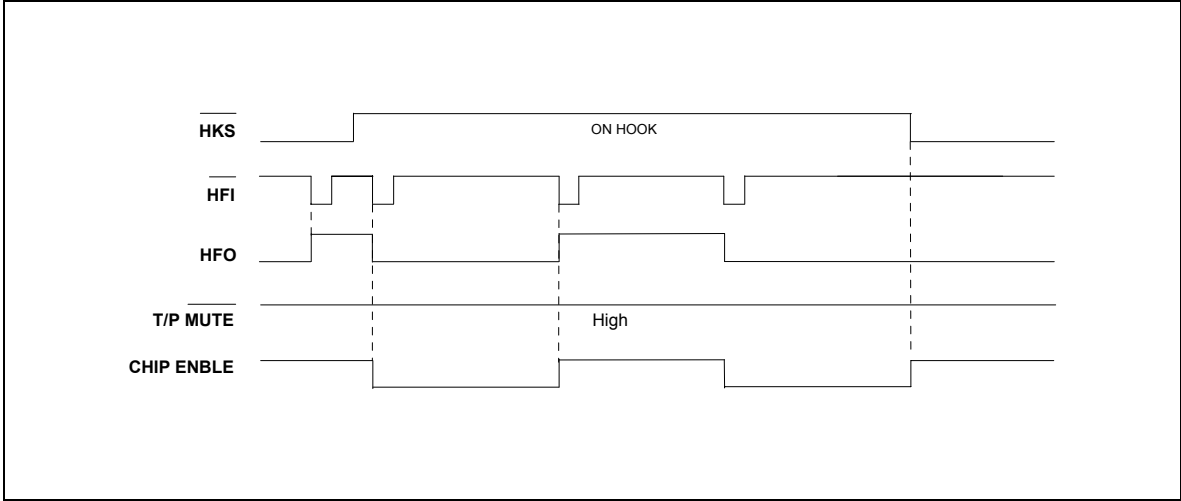

Figure 3. Handfree Timing Diagram

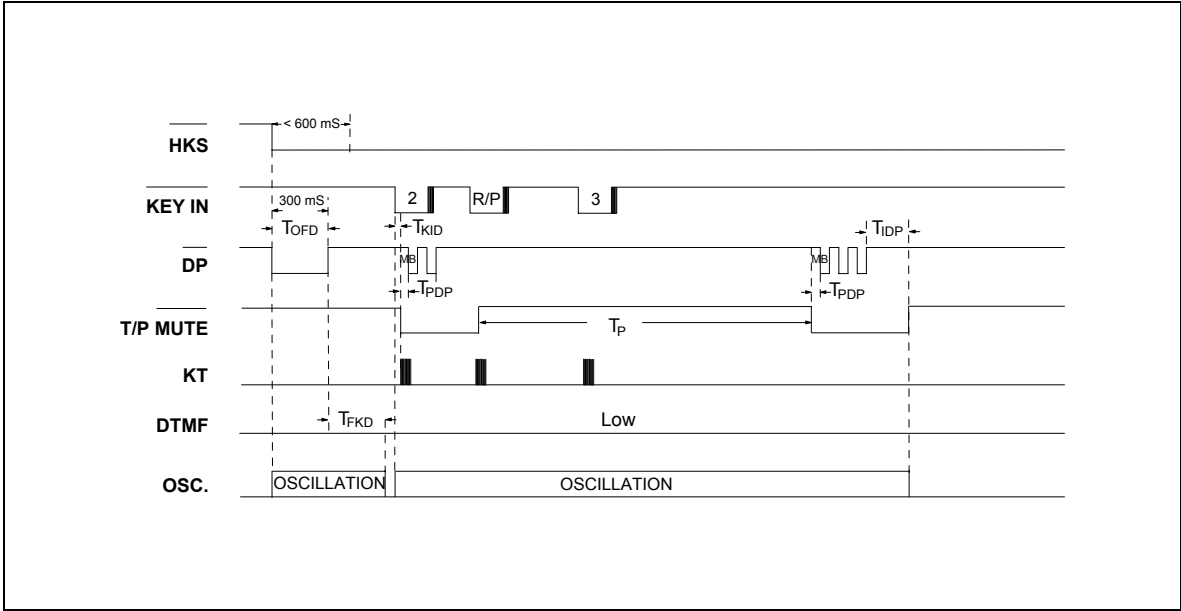

Figure 4. Pause Function Timing Diagram

W91530N SERIES



Timing Waveforms, continued

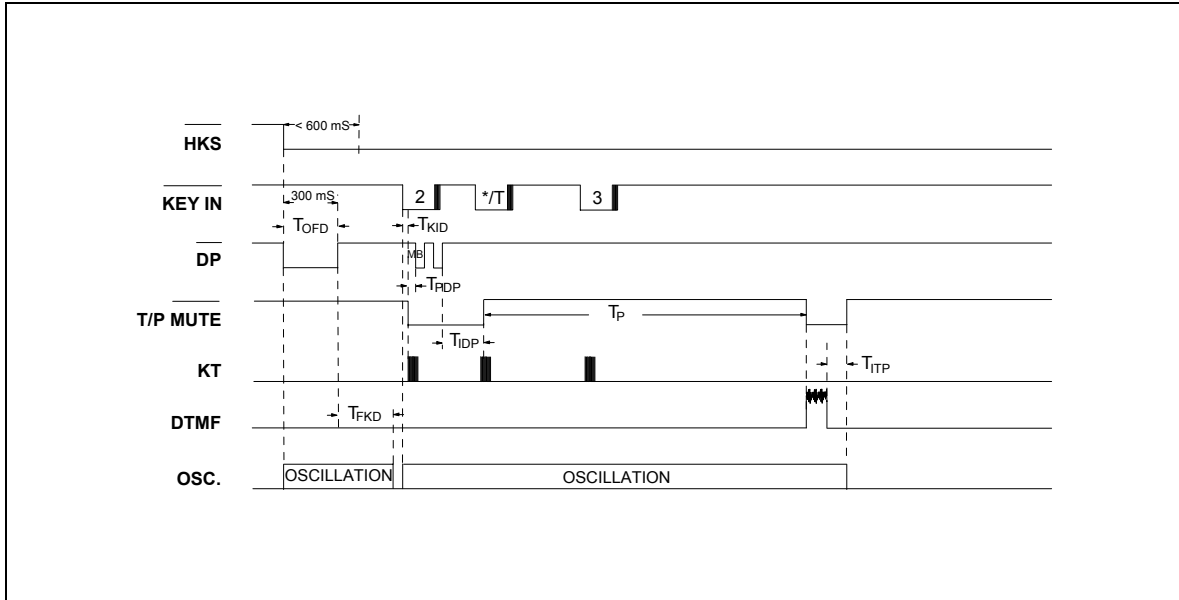

Figure 5(a). Pulse-to-tone Timing Diagram (except W91534AN)

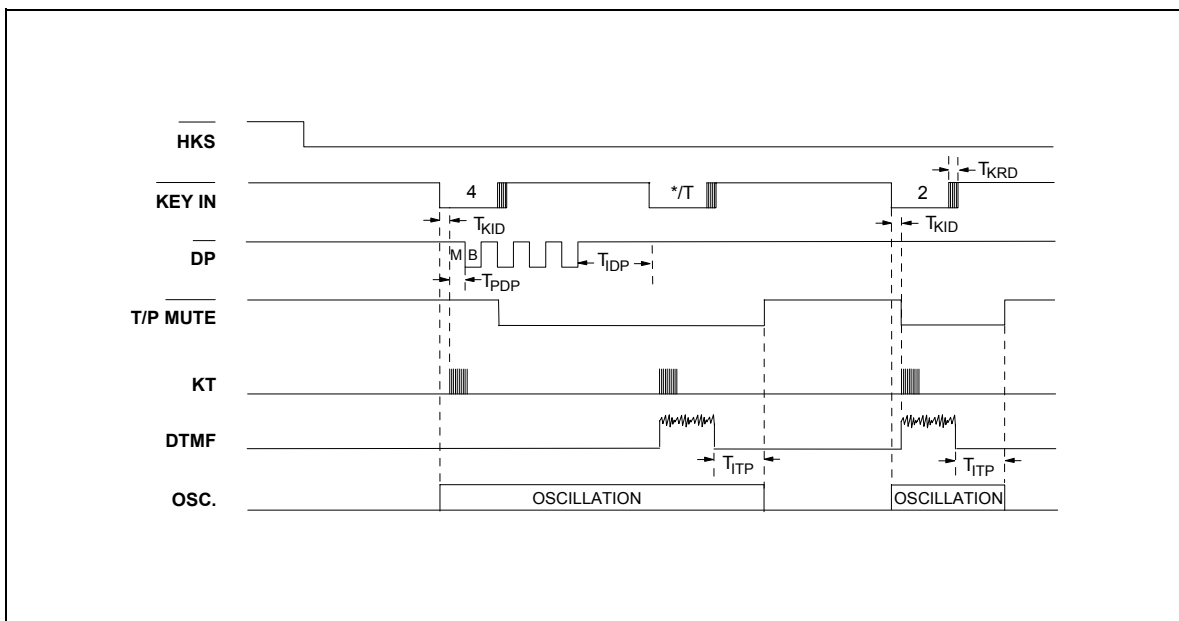

Figure 5(b). Pulse-to-tone Timing Diagram (W91534AN only)

W91530N SERIES



Timing Waveforms, continued

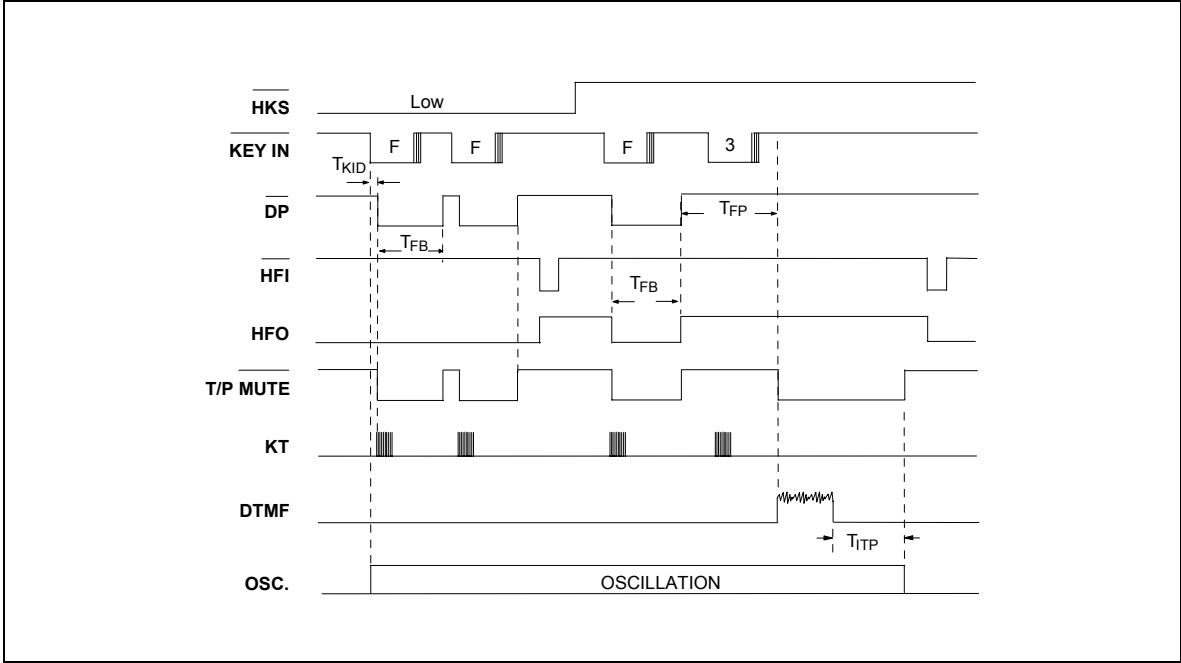

Figure 6. Flash Timing Diagram

W91530N SERIES



REVISION HISTORY

VERSION	DATE	PAGE	REASONS FOR CHANGE
A4	February 1999		-
A5	April 18, 2005	19	Add Important Notice

Important Notice

Winbond products are not designed, intended, authorized or warranted for use as components in systems or equipment intended for surgical implantation, atomic energy control instruments, airplane or spaceship instruments, transportation instruments, traffic signal instruments, combustion control instruments, or for other applications intended to support or sustain life. Further more, Winbond products are not intended for applications wherein failure of Winbond products could result or lead to a situation wherein personal injury, death or severe property or environmental damage could occur.

Winbond customers using or selling these products for use in such applications do so at their own risk and agree to fully indemnify Winbond for any damages resulting from such improper use or sales.



Headquarters

No. 4, Creation Rd. III,
Science-Based Industrial Park,
Hsinchu, Taiwan
TEL: 886-3-5770066
FAX: 886-3-5665577
<http://www.winbond.com.tw/>

Taipei Office

9F, No.480, Rueiguang Rd.,
Neihu District, Taipei, 114,
Taiwan, R.O.C.
TEL: 886-2-8177-7168
FAX: 886-2-8751-3579

Winbond Electronics Corporation America

2727 North First Street, San Jose,
CA 95134, U.S.A.
TEL: 1-408-9436666
FAX: 1-408-5441798

Winbond Electronics Corporation Japan

7F Daini-ueno BLDG, 3-7-18
Shinyokohama Kohoku-ku,
Yokohama, 222-0033
TEL: 81-45-4781881
FAX: 81-45-4781800

Winbond Electronics (Shanghai) Ltd.

27F, 2299 Yan An W. Rd. Shanghai,
200336 China
TEL: 86-21-62365999
FAX: 86-21-62365998

Winbond Electronics (H.K.) Ltd.

Unit 9-15, 22F, Millennium City,
No. 378 Kwun Tong Rd.,
Kowloon, Hong Kong
TEL: 852-27513100
FAX: 852-27552064

*Please note that all data and specifications are subject to change without notice.
All the trade marks of products and companies mentioned in this data sheet belong to their respective owners.*

Publication Release Date: April 18, 2005