

GENERAL DESCRIPTION

The TQ6113 and TQ6114 GIGADAC™ ICs are monolithic 8-bit GaAs DACs which contain input protection, a 9-wide master/slave latch array, eight binary-weighted current sources, clock and blanking circuitry. The GIGADAC's "blanking" capability makes it convenient to use this device in high-speed graphic displays. Complementary 1.125V (maximum) output swings when driving a 50Ω transmission line terminated by 50Ω are provided. 50Ω reverse terminations are provided *on the IC* for best settling performance.

The DAC ICs are fabricated using TriQuint's one micron gate depletion-mode GaAs MESFET process, which features "airbridge" second-layer wiring for minimum interconnect capacitance, MIM capacitors, and nichrome resistors. Due to the high inherent speed of the GaAs process, the DACs offers operation at clock rates of at least 600MHz (TQ6113) and 1000MHz (TQ6114), with 350 ps rise and fall times (10% - 90%), rapid settling times (1.3 ns to 1.6%), and low glitch impulse (<25 pV-sec).

The GIGADACs are supplied in a 44-pin multilayer ceramic package featuring wideband internal 50 ohm transmission line interconnects, analog/digital power supply and ground isolation, integral power supply bypassing, and gull-wing leads. Package dimensions are nominally 0.8" on a side, with leads set on 0.050" centers. Die versions of the parts are also available, for which *only* the DC characteristics are guaranteed. (Contact the factory for details.)

GIGADAC performance is specified over a case temperature range of 0°C to +70°C. Power dissipation for the ICs is nominally 2.5 W (TQ6113) and 3.5W (TQ6114).

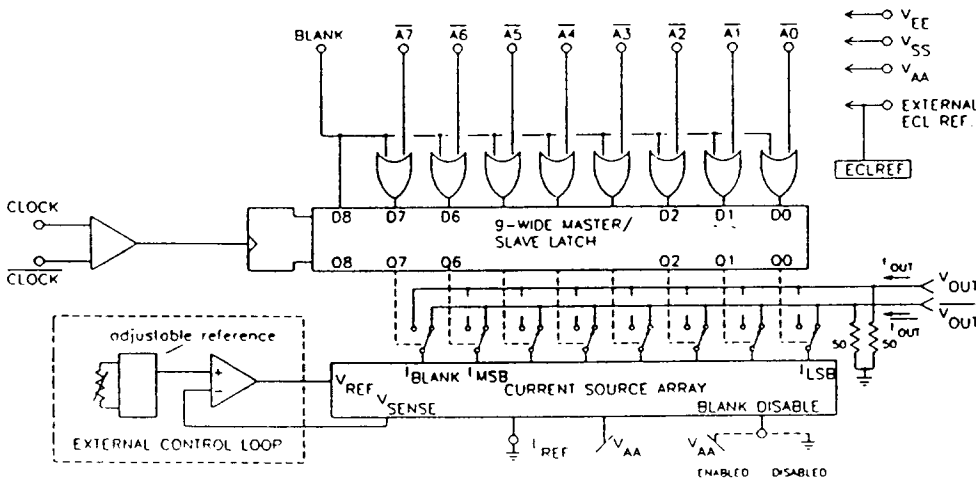

TQ6113 & TQ6114 8-Bit DACs

FEATURES:

- ❑ Fast conversion rate:
TQ6113 - 600Ms/s
TQ6114 - 1000Ms/s
- ❑ 8-Bit Resolution
- ❑ 1.125 V Output swing into 50Ω
- ❑ +1/-1.5V Output compliance range
- ❑ 0.2% Differential non-linearity (max)
- ❑ 350ps rise & fall times (10-90%)
- ❑ Settling times:
1.3ns to 1.6%
2ns to 0.4% (est.)
- ❑ 25pV-sec Glitch impulse
- ❑ GaAs-ECL digital inputs
- ❑ 44-pin surface mount ceramic package

APPLICATIONS:

- ❑ High resolution display generation
- ❑ Waveform and signal synthesis
- ❑ Video signal reconstruction
- ❑ High speed A/D conversion

PIN #	SIGNAL NAME	INTERFACE LEVEL	PIN #	SIGNAL NAME	INTERFACE LEVEL
1, 40	V _{EE}	-3.75 Volts	22, 23	V _{AA}	-12 Volts
2-4,6-8,13, 28,37-43	DGND	0 Volts	24	IREF	2.5mA for V _{FS} =1Vp-p
5	BLANK	600mV p-p centered at -1.3V @ DC	25	ECL REF	
10	CLOCK	1.0V p-p centered at -1.3V @ AC	26	A0	600mV p-p centered at -1.3V @ DC
11	CLOCK	1.0V p-p centered at -1.3V @ AC	27	A1	600mV p-p centered at -1.3V @ DC
12, 13, 33, 34	V _{SS}	-8.75 Volts	29	A2	600mV p-p centered at -1.3V @ DC
14,15,18	AGND	0 Volts	30	A3	600mV p-p centered at -1.3V @ DC
16	V _{OUT}	0 Volts to -1 Volts	31	A4	600mV p-p centered at -1.3V @ DC
17	V _{OUT}	-1 Volts to 0 Volts	32	A5	600mV p-p centered at -1.3V @ DC
19	BLANK DISABLE	Enable=V _{AA} Disable=AGND	35	A6	600mV p-p centered at -1.3V @ DC
20	VSENSE	V _{AA} +3V for V _{FS} =1Vp-p	36	A7	600mV p-p centered at -1.3V @ DC
21	VREF	V _{AA} +3V for V _{FS} =1Vp-p			

Pin Number, Signal Names and Interface Levels
(values shown are nominal unless noted)

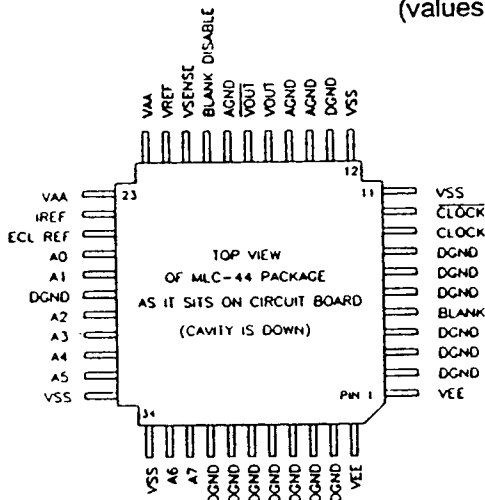

Package Pin Identification

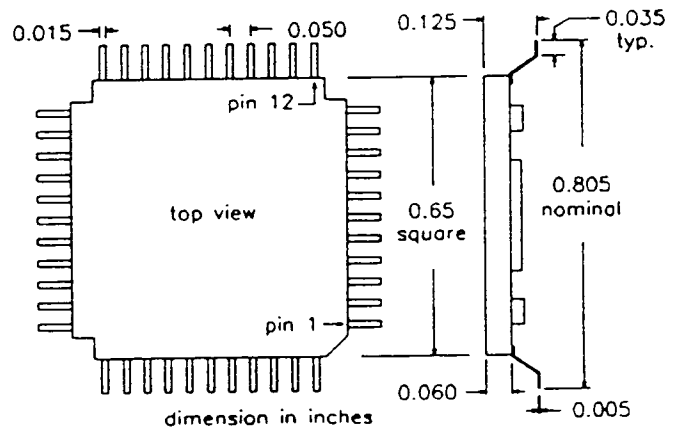

Package Dimensions

For further information contact:

Sales Department
TriQuint Semiconductor, Inc.
Group 700, P.O. Box 4935
Beaverton, OR 97076
(503) 644-3535
FAX: (503) 644-3198

The information provided herein is believed to be reliable; however, TriQuint assumes no responsibility for inaccuracies or omissions. TriQuint assumes no responsibility for the use of this information, and all such information shall be entirely at the user's own risk. Prices and specifications are subject to change without notice. No patent rights or licenses to any of the circuits described herein are implied or granted to any third party. TriQuint does not authorize or warrant any TriQuint product for use in life-support devices and/or systems.

QLSI and QED are registered trademark of TriQuint Semiconductor, Inc.