

Type ESA24SNG-LTE 2.4-Meter Vehicle Mountable Fully-Integrated, Variable Speed Rx/Tx Earth Station Antenna

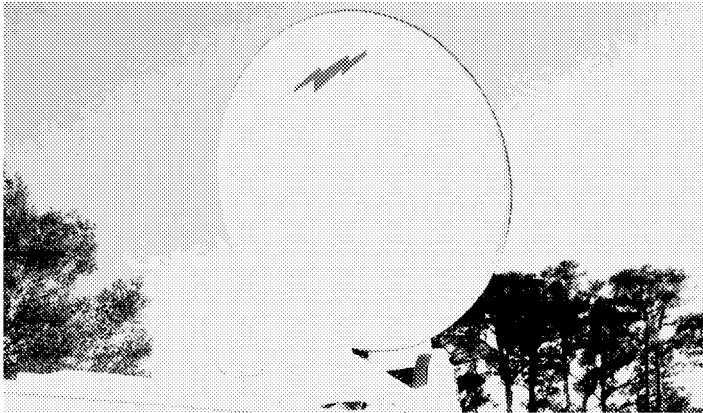

Mechanical

Configuration	ESA24SNG-LTE
Feed Type	Prime Focus, Offset
Reflector Material	Precision-Formed Aluminum
Reflector Segments	1
Mount Type	EI over Az, Pedestal
Material/Finish	
Reflector	Aluminum
Feed	Brass
Positioner	Aluminum
Feed Arm	
Capacity	180 lbs
Area	29.5" x 36.5" x 12" High (8.3 ft ³)
Antenna Pointing Range, Continuous	
Elevation	65°
Azimuth	180°, 270°, 350°
Polarization	±90°
Wind Loading, Survival	65 mph (105 km/h) in any position of operation
Wind Loading, Operational (motor drives)	45 mph (72 km/h), gusting to 65 mph (105 km/h)
Temperature, Operational	-40° to 125° F (-40° to 52° C)
Rain	4 in (102 mm) per hour
Solar Radiation	360 BTU/hr/ft ² (1135 Watts/m ²)
Relative Humidity	100%
Atmospheric Conditions	Moderate coastal/industrial areas. Severe conditions require additional protection.
Positioner Travel Rates, degrees per second	
Elevation	0.25° to 1.0°/second
Azimuth	0.25° to 1.0°/second
Polarization	0.5° to 2.0°/second
Weight, Net	690 lbs
Electrical Requirements	
Local Unit	
Voltage	190-250 Vac, 1ø, 50/60 Hz
Power	1.5 kVa, total
Remote Unit	
Voltage	100-240 Vac, 1ø, 50/60 Hz
Power	1.3 amps, maximum
Maximum Branch-Circuit, Short-Circuit and Ground-Fault Protection Device:	
1ø Input	20 amp inverse time breaker

Electrical

Operating Frequency Band		
Ku-Band Receive	10.95-12.75 GHz	
Ku-Band Transmit	14.0-14.5 GHz	
Gain at circular waveguide flange of feed		
2-Port		
Rx Frequency	11.950 GHz	
Rx Gain	47.7	
Tx Frequency	14.25 GHz	
Tx Gain	49.2	
4-Port		
Rx Frequency	11.950 GHz	
Rx Gain	47.4	
Tx Frequency	14.25 GHz	
Tx Gain	48.9	
Polarization	Linear	
Polarization Discrimination, on axis across 1dB contour	>35 dB 27 dB	
Beamwidth, at Midband	Ku-Band	
3 dB Receive (Transmit)	0.72° (0.61°)	
15 dB Receive (Transmit)	1.42 (1.33°)	
Antenna Noise Temperature under clear sky conditions, at 68° F (20° C), at the circular waveguide flange of the feed.		
Elevation	Ku-Band (2-Port)	Ku-Band (4-Port)
10°	44°	72°
30°	33°	61°
Antenna VSWR*, Transmit and Receive	<1.3:1	
Radiation Pattern Performance	PE's #4471 and #4472	
Tx Power Handling Capability		
2-Port Network, maximum, W	2000	
4-Port Network, maximum, W	600	
Feed Interface Flanges, Receive/Transmit	WR75	
Isolation, minimum, Tx into Rx, dB	40 (2-Port) 85 (4-Port)	
Power Density Data		
Projected Width of Reflector	96 in	
Area of Feed Horn Aperture	10.65 in ²	
Focal Length	60 in	
Optional Cross Axis Kit, loss, 1 dB	1XAK-LTE (1 run) 2XAK-LTE (2 runs)	

All designs, specifications and availabilities of products and services presented in this Bulletin are subject to change without notice.

Pattern Envelope #4471 Antenna Types ESA24VSM-KU and ESA24SNG-LTE

Table of Break Points Defining the PE (See Note)

Angle (± Deg)	CO (dB)	Angle (± Deg)	CO (dB)	Angle (± Deg)	CO (dBi)	Angle (± Deg)	CO (dBi)
1.0	19.0	12.0	46.7	1.0	29.0	12.0	1.3
1.3	21.9	12.8	49.3	1.3	26.1	12.8	-1.3
1.4	23.4	40.0	49.3	1.4	24.6	40.0	-1.3
1.6	25.7	45.0	52.2	1.6	22.3	45.0	-4.2
1.7	26.4	52.0	52.2	1.7	21.6	52.0	-4.2
1.8	27.1	53.2	53.2	1.8	20.9	53.2	-5.2
2.0	28.4	67.0	53.2	2.0	19.6	67.0	-5.2
2.1	29.0	68.0	58.0	2.1	19.0	68.0	-10.0
2.3	29.7	103.5	58.0	2.3	18.3	105.5	-10.0
3.0	32.0	104.0	55.0	3.0	16.0	104.0	-7.0
4.0	35.3	137.5	55.0	4.0	12.7	137.5	-7.0
5.0	38.4	140.0	52.5	5.0	9.6	140.0	-4.5
5.7	41.2	145.0	52.5	5.7	6.8	145.0	-4.5
7.0	41.2	154.7	61.0	7.0	6.8	154.7	-13.0
7.8	44.5	170.0	61.0	7.8	3.5	170.0	-13.0
9.8	44.5	170.0	64.1	9.0	3.5	170.0	-16.1
10.0	45.3	180.0	64.1	10.0	2.7	180.0	-16.1
10.4	46.7			10.4	1.3		

Table of RPE Values at Small Angle Increments

Angle (± Deg)	CO (dB)	CO (dBi)	Angle (± Deg)	CO (dB)	CO (dBi)
1.0	19.0	29.0	-----	-----	-----
3.0	32.0	16.0	103.0	58.0	-10.0
4.0	35.3	12.7	104.0	55.0	-7.0
5.0	38.4	9.6	-----	-----	-----
6.0	41.2	6.8	137.0	55.0	-7.0
7.0	41.2	6.8	138.0	54.5	-6.5
8.0	44.5	3.5	139.0	53.5	-5.5
9.0	44.5	3.5	140.0	52.5	-4.5
10.0	45.3	2.7	-----	-----	-----
11.0	46.7	1.3	145.0	52.5	-4.5
12.0	46.7	1.3	146.0	53.4	-5.4
13.0	49.3	-1.3	147.0	54.3	-6.3
-----	-----	-----	148.0	55.1	-7.1
40.0	49.3	-1.3	149.0	56.0	-8.0
41.0	49.9	-1.9	150.0	56.9	-8.9
42.0	50.5	-2.5	151.0	57.8	-9.8
43.0	51.0	-3.0	152.0	58.6	-10.6
44.0	51.6	-3.6	153.0	59.5	-11.5
45.0	52.2	-4.2	154.0	60.4	-12.4
-----	-----	-----	155.0	61.0	-13.0
52.0	52.2	-4.2	-----	-----	-----
53.0	53.0	-5.2	170.0	61.0	-13.0
54.0	53.2	-5.2	171.0	64.1	-16.1
-----	-----	-----	-----	-----	-----
67.0	53.2	-5.2	180.0	64.1	-16.1
68.0	58.0	-10.0	-----	-----	-----

Note: The PE is defined by connecting these points with straight lines as graphically displayed below.

Pattern Envelope 4471

Antenna Type Number
ESA24VSM-KU/ESA24SNG-LTE

10.95 - 12.75 GHz

Gain: 47.6 ±0.2 dBi @ 11.95 GHz

15 dB Beamwidth: 1.42°

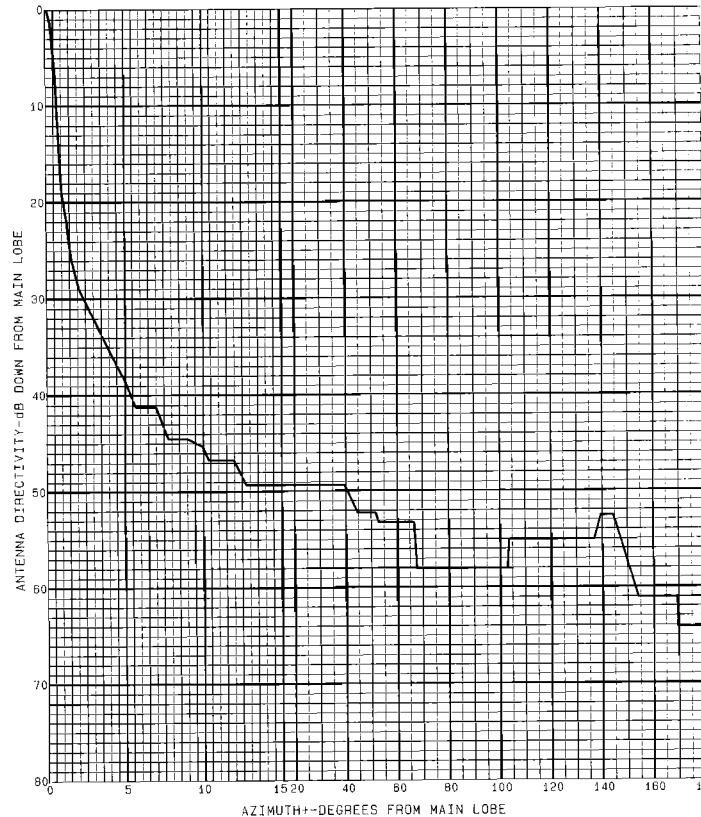

This antenna complies with FCC Regulation 25-209 as amended September 6, 1983 for 2 degree satellite spacing.

Pattern Envelope #4472 Antenna Type ESA24VSM-KU and ESA24SNG-LTE

Table of Break Points Defining the PE (See Note)

Angle (± Deg)	CO (dB)	Angle (± Deg)	CO (dB)	Angle (± Deg)	CO (dBi)	Angle (± Deg)	CO (dBi)
1.0	22.1	9.5	54.8	1.0	27.9	9.5	-1.4
1.1	24.4	11.0	54.8	1.1	25.6	11.0	-1.4
1.2	26.3	12.0	56.6	1.2	23.7	12.0	-4.0
1.3	28.1	12.2	56.6	1.3	21.9	12.2	-4.6
1.4	30.0	14.0	60.0	1.4	20.0	14.0	-4.6
2.0	30.0	14.6	60.0	2.0	20.0	14.6	-4.8
3.0	35.4	20.0	65.1	3.0	14.6	20.0	-4.8
4.0	41.1	22.6	65.1	4.0	8.9	22.6	-6.6
5.0	43.0	35.0	58.0	5.0	7.0	35.0	-6.6
5.2	43.8	42.5	60.0	5.2	6.2	42.5	-10.0
7.0	43.8	146.0	60.0	7.0	6.2	146.0	-10.0
7.7	49.3	152.1	65.1	7.7	0.7	152.1	-15.1
9.0	49.3	180.0	65.1	9.0	0.7	180.0	-15.1

Table of RPE Values at Small Angle Increments

Angle (± Deg)	CO (dB)	CO (dBi)	Angle (± Deg)	CO (dB)	CO (dBi)
1.0	22.1	27.9	35.0	56.6	-6.6
2.0	30.0	20.0	36.0	57.1	-7.1
3.0	35.4	14.6	37.0	57.5	-7.5
4.0	41.1	8.9	38.0	58.0	-8.0
5.0	43.0	7.0	39.0	58.4	-8.4
6.0	43.8	6.2	40.0	58.9	-8.9
7.0	43.8	6.2	41.0	59.3	-9.3
8.0	49.3	0.7	42.0	59.8	-9.8
9.0	49.3	0.7	43.0	60.0	-10.0
10.0	51.4	-1.4	-----	-----	-----
11.0	51.4	-1.4	146.0	60.0	-10.0
12.0	54.0	-4.0	147.0	60.8	-10.8
13.0	54.6	-4.6	148.0	61.7	-11.7
14.0	54.6	-4.6	149.0	62.5	-12.5
15.0	54.8	-4.8	150.0	63.3	-13.3
-----	-----	-----	151.0	64.2	-14.2
20.0	54.8	-4.8	152.0	65.0	-15.0
21.0	55.5	-5.5	153.0	65.1	-15.1
22.0	56.2	-6.2	-----	-----	-----
23.0	56.6	-6.6	180.0	65.1	15.1

Note: The PE is defined by connecting these points with straight lines as graphically displayed below.

Pattern Envelope 4472

Antenna Type Number
ESA24VSM-KU/ESA24SNG-LTE

14.00 - 14.50 GHz

Gain: 49.4 ±0.2 dBi
@ 14.25 GHz

15 dB Beamwidth: 1.32°

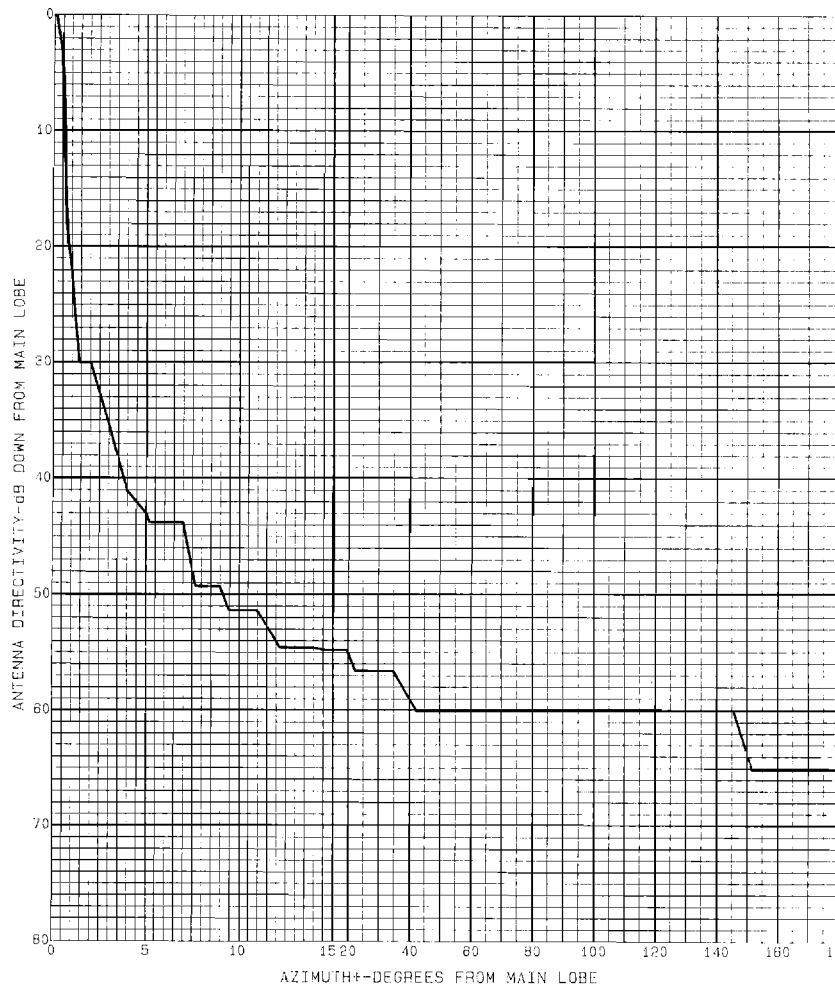

This antenna complies with FCC Regulation 25-209 as amended September 6, 1983 for 2 degree satellite spacing.

Antenna Load Table

Table 1 address 65 mph combined wind and weight loads resolved to the base of the positioner. Several load cases have been considered. The cases which produce the maximum individual loads and moments are reported in Table 1. Electronics integration will be performed by others, so this weight may vary. Forces are in pounds and moments are in inch-pounds.

Table 1 - SNG Attachment Interface Loads
Wind at 65 mph, Combined Wind and Dead Weight

Case	EI Angle (degrees)	Wind Angle (degrees)	Fx (lbs)	Fy (lbs)	Fz (lbs)	Mx (in-lbs)	My (in-lbs)	Mz (in-lbs)
$F_{x_{max}}$	30	0	-806	0	-785	180	-62348	-269
$F_{y_{max}}$	20	135	309	-35	-683	2422	31694	-4188
$F_{z_{max}}$	70	15	-489	4	-1227	-583	-59834	146
$M_{x_{max}}$	90	90	30	-35	-602	5401	-2726	362
$M_{y_{max}}$	30	0	-806	0	-785	180	-62348	-69
$M_{z_{max}}$	0	139	286	-26	-779	713	32918	-4240

Shock Load, Maximum

$S_z = 3.7 G$ $S_x = 1.7 G$ $S_y = 0.3 G$

Boom Stop Location/Installation

Locate boom stops as shown. Boom stops should be adequately secured and located so that in the event of severe shock, azimuth rotation is prevented while the antenna is in the stowed position. The actual geometry of each antenna/vehicle installation may vary significantly, therefore any boom stop geometry that will prevent azimuth rotation as indicated on the drawing will meet this requirement.

Note: Boom stops are not supplied with the antenna.

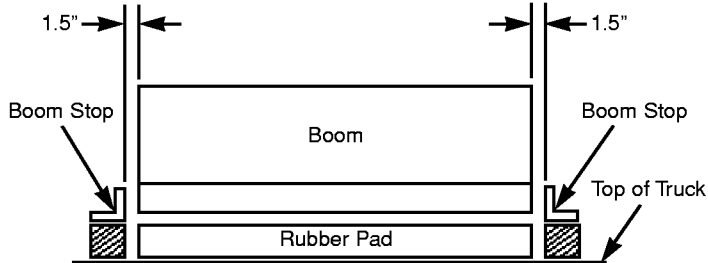

Boom Stop Mounting Position

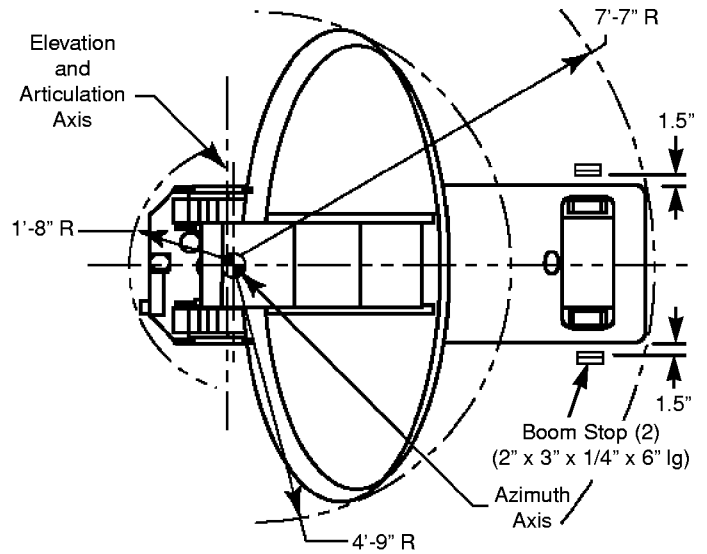

Antenna Clearance Envelope - Top View

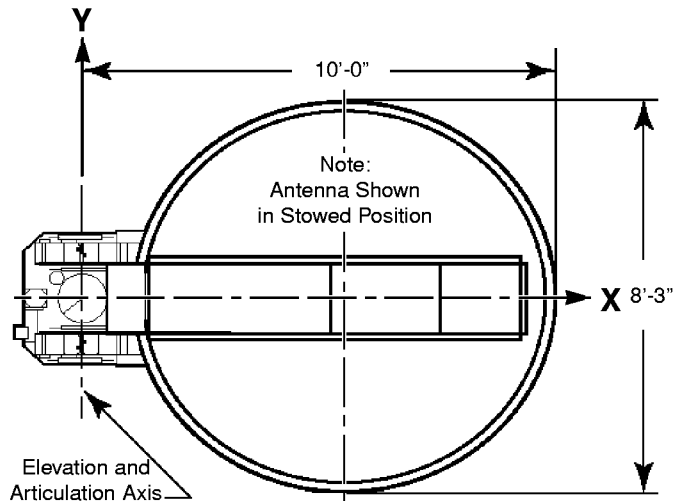

Antenna Overall Dimensions - Top View

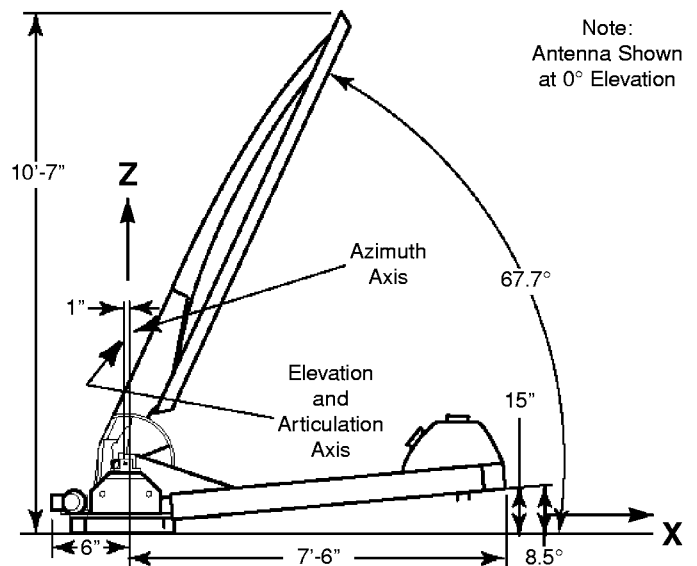

Antenna Clearance Envelope - Side View

All designs, specifications and availabilities of products and services presented in this Bulletin are subject to change without notice.

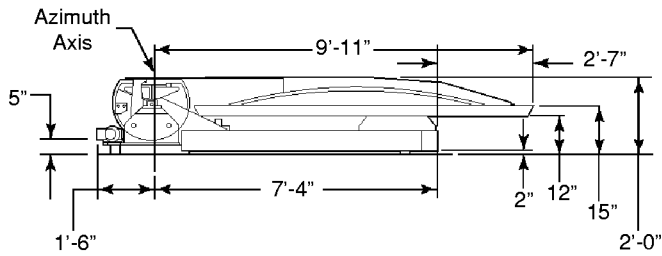

Antenna Overall Dimensions - Side View

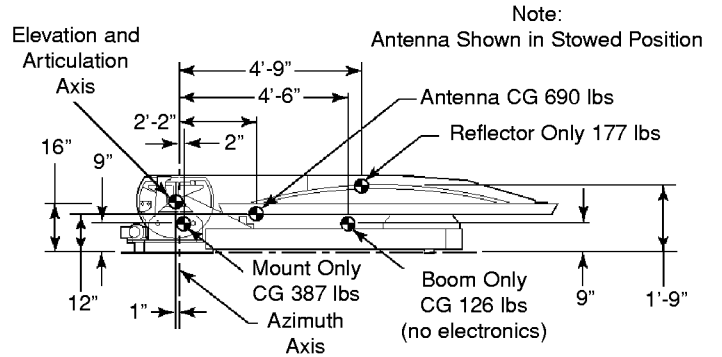

Approximate Antenna Weight Distribution

Note:
Antenna Shown
at 65° Elevation

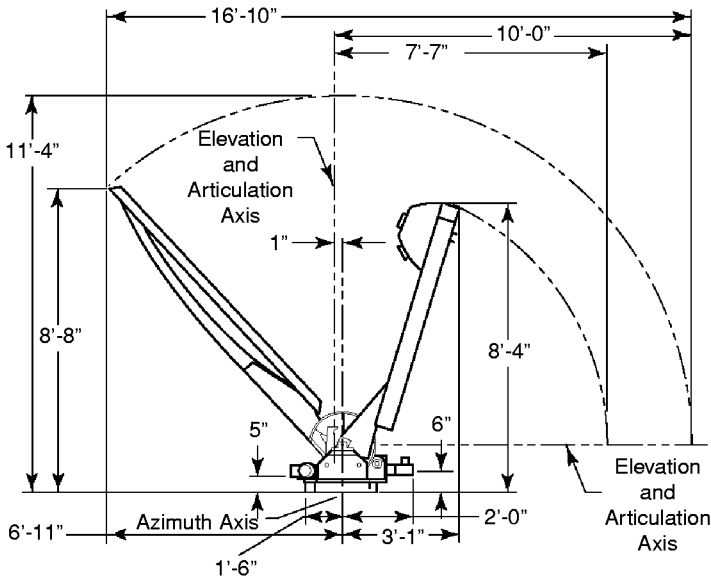

Antenna Clearance Envelope and Center of Gravity - Side View

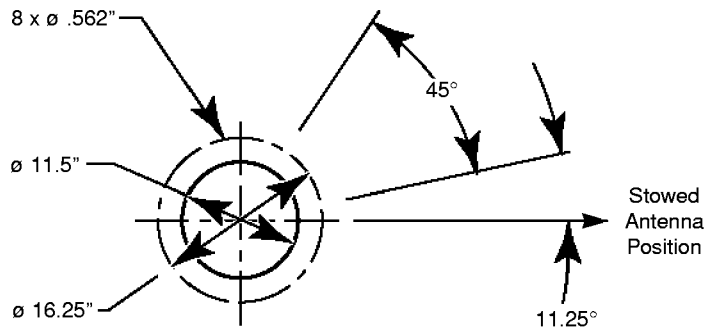

Mounting Pattern on Truck

Note: Enclosure Volume = 8.3 Cubic Feet

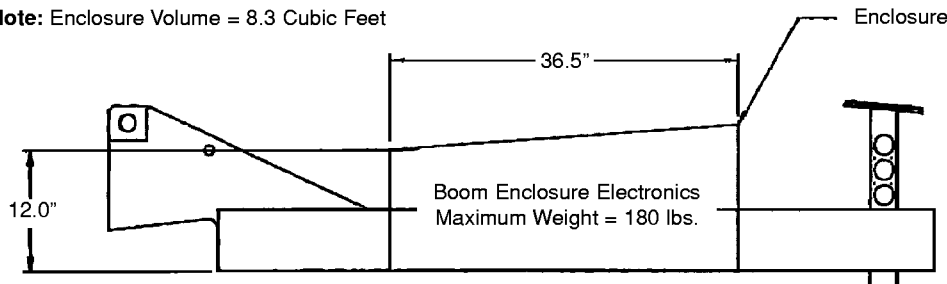

Boom Enclosure Area

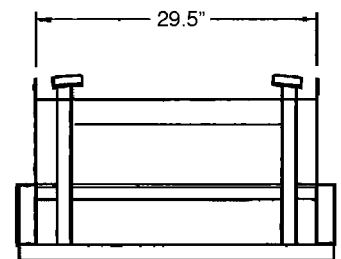

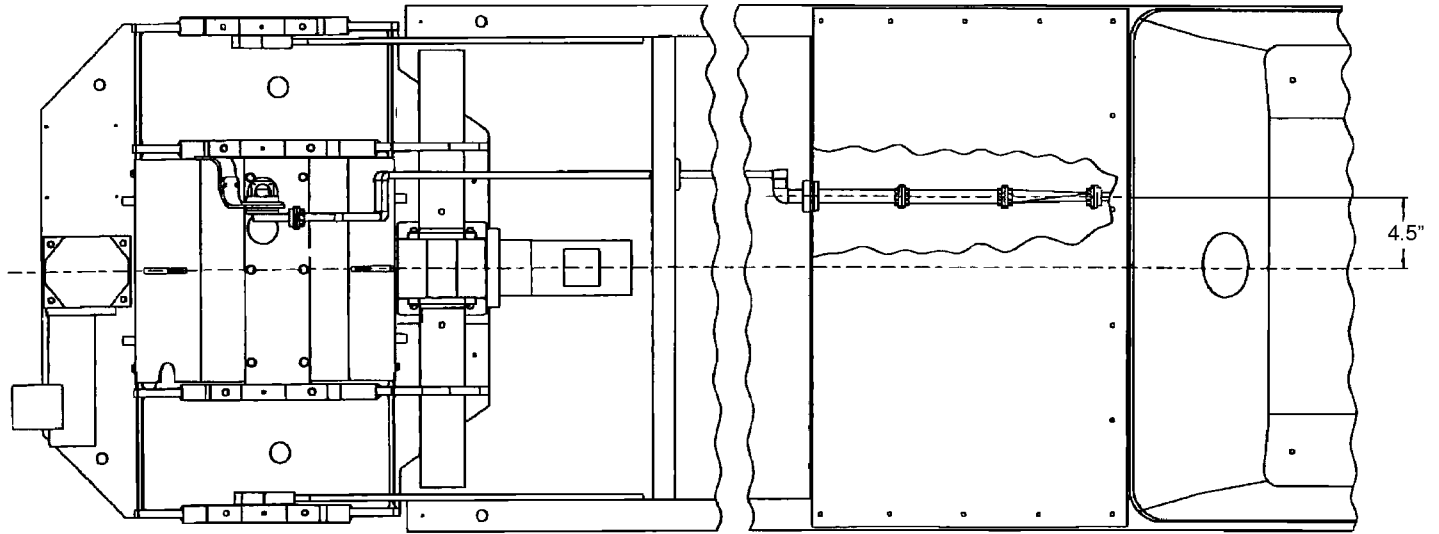

Single Run Cross Axis Kit

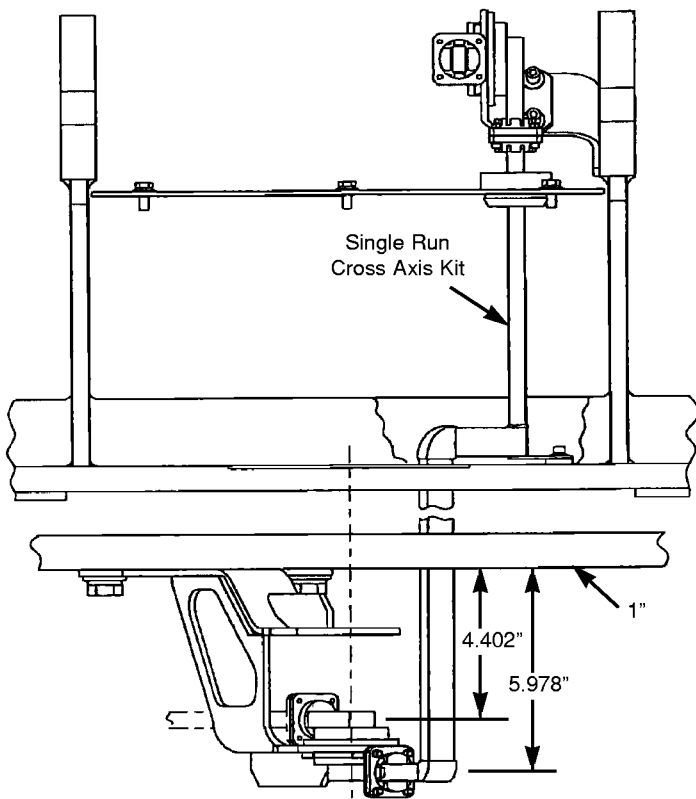

Single Run Cross Axis Kit

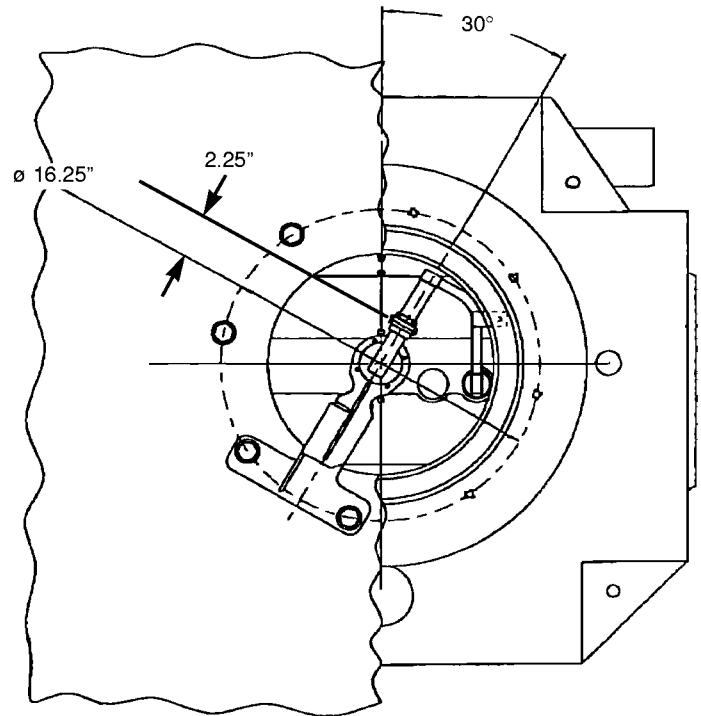

Single Run Cross Axis Kit

Note: Single run for Type 1XAK-LTE shown, total loss = 0.1 dB.
For dual run Type 2XAK-LTE, refer to 240132.

VSC-1 Antenna Control System

Introduction

The VSC-1 is a Variable Speed Controller designed to provide control for the Andrew ESA24SNG-LTE Satellite News Gathering (SNG) Antenna.

The VSC-1 features tactile feedback controls which allow easy system setup and operation. Display of system information is provided via an easy to read 8 line by 40 Character LED Backlit Liquid Crystal Display and multicolored Light Emitting Diode Indicators. The system incorporates a highly informative multilevel user interface to provide the end user with the most intuitive feedback available.

The design emphasis of the VSC-1 provides current and future customers with the highest quality, reliability, and maintainability available in the antenna positioning market today.

System Configuration

The controller system is comprised of a Variable Frequency Controller (VFC) Unit, a Variable Frequency Drive (VFD) Unit, a VSC Handheld Control Unit, a Remote Control Unit, Dual Axis Inclinometer Unit, Azimuth, Elevation, and Polarization Resolver Assemblies, Interconnecting Cables, and an Operation & Maintenance Manual. An optional GPS Receiver Unit is also available. A system block diagram is shown below.

Features:

- **Automatic Deploy**
- **Automatic Stow**
- **Manual Jog Control**
- **Move To Control**
 - **12 Active Satellite Positions**
 - **Selectable Table for Worldwide Satellites**
 - **User Selectable AZ, EL, POL**
- **Update Control (allows user peaked satellite position to back-calculate actual vehicle heading)**
- **Complete Variable Speed all Axes including Polarization**
- **AZ, EL, and POL Angles Displayed at VSC Handheld Control Unit**
- **Full Diagnostic Self-Test Performed at Startup and Self-Test Continuously Monitored during Operation**
- **Worldwide Operation in both Northern and Southern Hemispheres**
- **Antenna Positioning Resolution of 0.01° all Axes**
- **Monitor & Control Serial Port**
- **Form A Summary Alarm Contacts provided at Remote Unit**
- **Look-Up Latitude/Longitude Table**
- **Manual Override for Stow/Deploy and Positioning**
- **Manual Brake Override If Power Failure Occurs**
- **System is Fully-Intregrated at Factory**
- **Optional GPS Receiver to Assist in Satellite Acquisition**

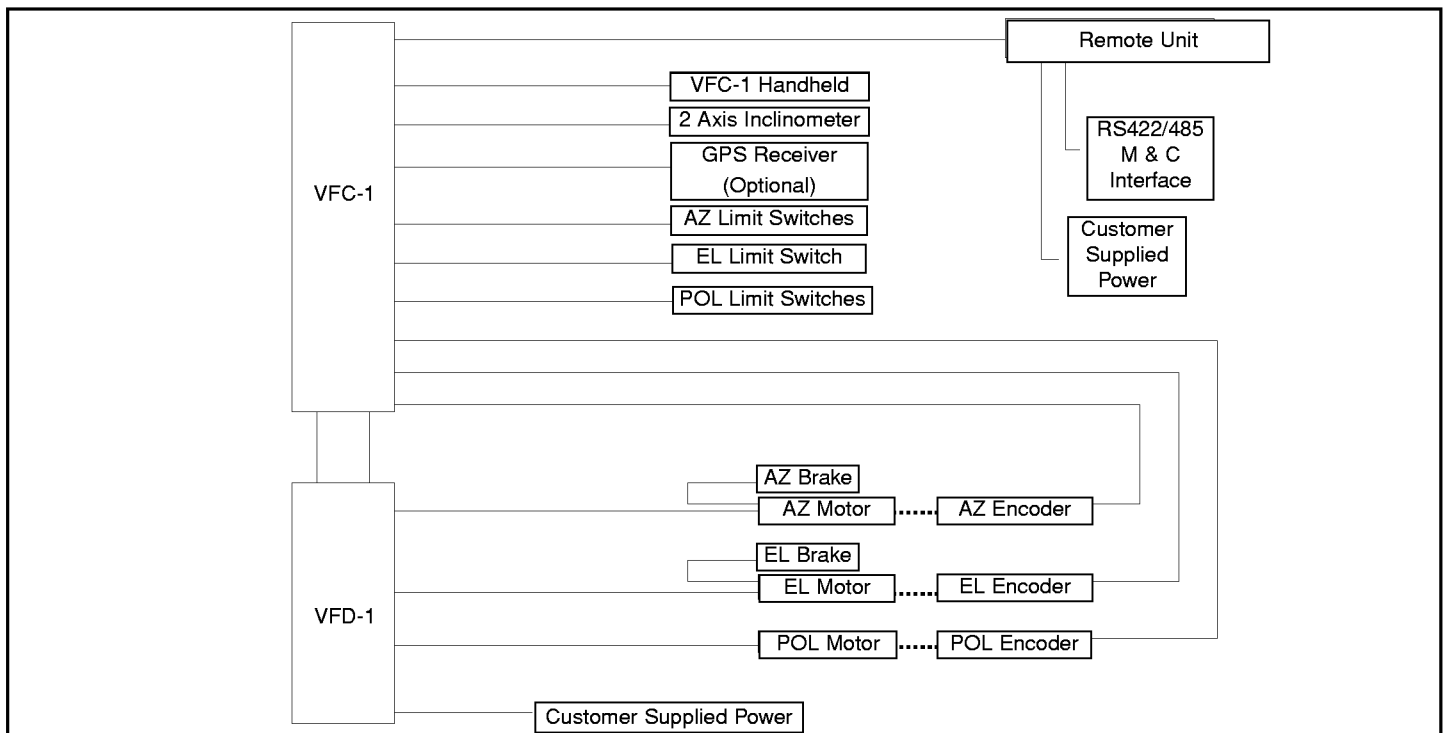

VSC-1 System Block Diagram

System Components

VFC-1 Variable Frequency Controller Unit

The VFC-1 (pictured below) is the main system component. It contains the control logic electronics to control the VFD-1 which in turn produces the motor drive commands. Antenna control logic is supplied to the VFD-1 as a result of inputs from the resolvers, dual axis inclinometer, limit / status switches, VFC-1, Remote and VSC Handheld Control Unit. If the GPS Receiver Option Unit is available, the VFC-1 also uses the signals produced by this device to supply antenna position control logic to the VFD-1 to provide latitude and longitude information. The unit is packaged in a wall mount NEMA 4X weather proof enclosure and is supplied with two 3 foot cables for interconnect to the VFD-1. Unit dimensions are 12.5 inches wide x 14.5 inches high x 8.3 inches deep; weight is 19 pounds.

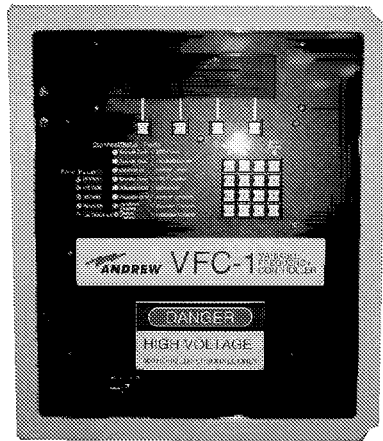

Type 301339 Variable Frequency Controller Unit

VFD-1 Variable Frequency Drive Unit

The VFD-1 (pictured below) provides the motor control portion of the system. It accepts commands from the VFC-1 and in turn provides direction and speed controlled power to the antenna motors. The VFD-1 also receives the primary motor power input and provides power to the VFC-1. The unit is packaged in a wall mount NEMA 4X weather proof enclosure. Unit dimensions are 10.4 inches wide x 15.3 inches high x 8.2 inches deep; weight 14 pounds.

VSC Handheld Control Unit

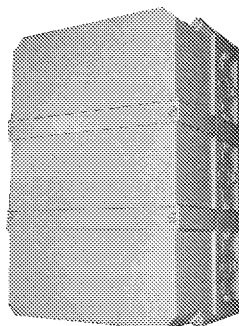

Type 301340 Variable Frequency Drive Unit

VSC Handheld Control Unit

The VSC Handheld Control Unit (pictured below) allows remote handheld control of all three axes of the antenna from up to 30 feet from the VFC-1. The unit features full direction and speed control, fault and status reporting, as well as full digital display of axes angular position. It is packaged in a NEMA 4X weather proof portable enclosure with a hinged flip-up controls cover door. Unit dimensions are 4.3 inches wide x 7.0 inches high x 2.9 inches deep; weight 2 pounds.

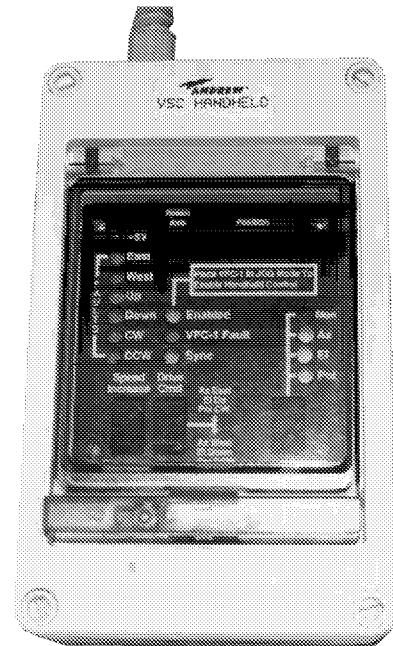

Type 301144 Handheld Control Unit

Remote Control Unit

The Remote Control Unit (pictured below) provides the remote interface to the VFC-1. It duplicates operator level control of the VFC-1 at a remote location. Full fault and status reporting are provided as well as all control features of the VFC-1 with the exception of antenna integration level setup parameter access. Remote monitoring and control (M&C) are provided through a RS422/485 serial interface. Front panel color is black. The unit is packaged in a standard ANSI/EIA 2 rack height package. Unit dimensions are 19.0 inches wide x 3.5 inches high x 10.2 inches deep; weight 9.5 pounds.

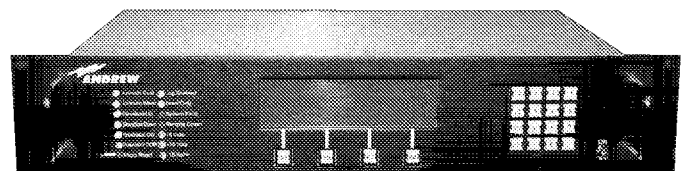

Type 301124 Remote Control Unit

Dual Axis Inclinometer Unit

The Dual Axis Inclinometer (pictured below) provides dual axis tilt information to the VFC-1. It offsets the angular position readout to correct for pitch and roll of the antenna due to the vehicle being parked on a non-level surface. The unit is attached to the rear of the antenna panning frame. It is packaged in a NEMA 4X weather proof enclosure. The unit dimensions are 5.2 inches wide x 5.2 inches high x 2.3 inches deep; weight 1 pound.

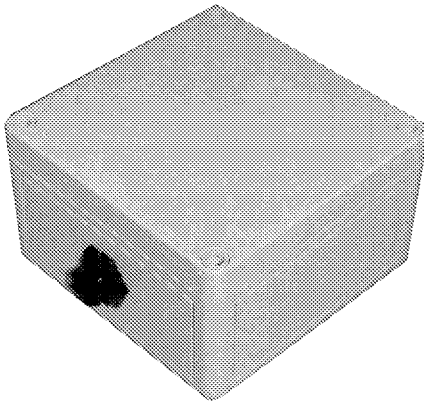

Type 301145 Dual-Axis Inclinometer Unit

GPS Receiver Option Kit

The GPS Receiver Option Kit (pictured below) allows the VSC-1 System to be upgraded to assist in satellite acquisition. The kit includes the GPS Unit with GPS antenna, 35 feet of connectorized cable, an illuminated hand bearing compass and installation instructions. The GPS Receiver provides the VFC-1 with vehicle latitude and longitude information. The indoor mounting unit is packaged in a NEMA 4X enclosure with retractable GPS antenna cable strain relief for different antenna cable length requirements. Unit dimensions are 5.2 inches wide x 5.2 inches high x 2.3 inches deep; weight 1.5 pound including GPS antenna and interconnect cable. The dimensions of the GPS antenna are 3 inches wide x 3 inches high x 0.7 inches deep.

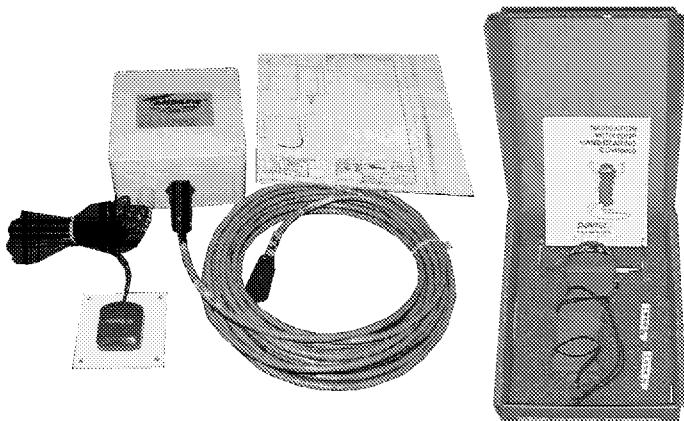

Type 301601 GPS Receiver Option Kit with GPS-COMP

System Specifications

Position Feedback:

Absolute angle measurement supplied by encoders

GPS Receiver Performance (option): GPS-COMP

Position Accuracy: 2 to 5 meters

Dual Axis Inclinometer Performance:

Range: +/-20 degrees

Threshold/Resolution: 0.01 degrees

Remote Interfaces:

VSC Handheld: RS422 serial communication

Remote to VFC-1: RS422 serial communication

Remote M&C Interface: RS422/485 serial communication

Dual-Axis Inclinometer: RS422 serial communications

GPS Receiver Unit: RS232C serial communication

Summary Alarm Monitor:

Form A contact type (open on alarm), up to 200VDC at 0.5 amps (10 Watts max)

Parameter Storage: Non-volatile memory microchip: 10 year plus life expectancy

Motor Control Method:

3 phase variable frequency

VFC-1, VFD-1, VSC Handheld, and Inclinometer Operating/Storage Environment:

Operational: -40°F to 125°F (0 to 100% condensing)

Storage: -40°F to 158°F (0 to 100% condensing)

Remote Unit Operating/Storage Environment:

Operational: 32°F to 122°F (0 to 90% non-condensing)

Storage: -4°F to 140°F (0 to 90% non-condensing)

Optional GPS Receiver Unit

Operating/Storage Environment:

Operational: -40°F to 185°F (0 to 90%)

Storage: -55°F to 185°F (0 to 90%)

VSC-1 System Power Requirements:

Motor/logic power to VFD-1: 190-250 VAC

50/60 ±2 Hertz, 1 phase, 1.5 KVA (max)

Remote Unit Power Requirements:

100 - 240 VAC, 50/60 ±3 Hertz, 1 phase, 1.3 Amps (max)

Note: Specifications Subject to Change Without Notice