

Document No.	853-0670
ECN No.	99799
Date of Issue	June 14, 1990
Status	Product Specification
ECL Products	

10160

Parity Checker/Generator

12-Bit Parity Checker/Generator

FEATURES

- Typical propagation delay: 5.0ns
- Typical supply current ($-I_{EE}$): 62mA

DESCRIPTION

The 10160 is a 12-bit Parity Checker or Generator. The output goes High when an odd number of inputs are High. If parity detection or generation is required for less than 12 bits, all unused inputs can be left open due to integrated pull-down resistors which avoid the need for a supply voltage.

ORDERING INFORMATION

DESCRIPTION	ORDER CODE
16-Pin Plastic DIP	10160N
16-Pin Ceramic DIP	10160F

PIN DESCRIPTION

PINS	DESCRIPTION
$D_0 - D_{11}$	Data Inputs
Q	Data Output

PIN CONFIGURATION

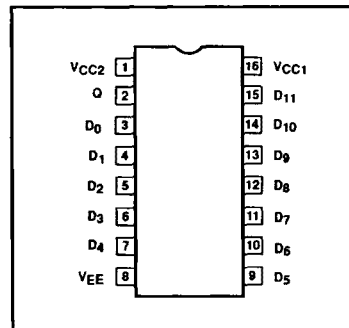

LOGIC DIAGRAM

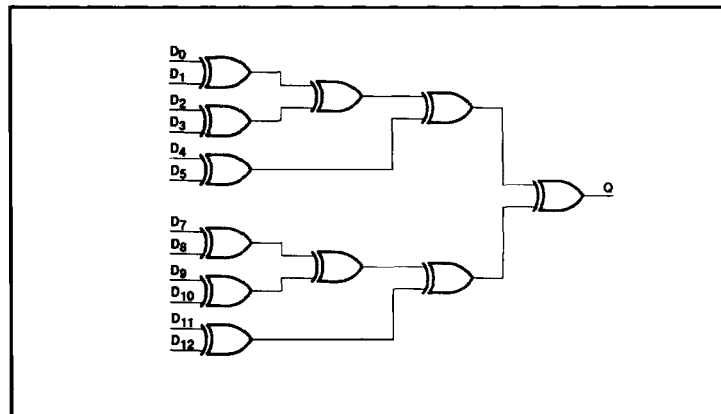

Parity Checker/Generator

10160

FUNCTION TABLE

SUM OF INPUTS AT HIGH STATE	Q
Odd	H
Even	L

H = High Voltage Level

L = Low Voltage Level

ABSOLUTE MAXIMUM RATINGS

SYMBOL	PARAMETER	LIMITS	UNIT	
V_{EE}	Supply voltage	-8.0	V	
V_{IN}	Input voltage (V_{IN} should never be more negative than V_{EE})	0 to V_{EE}	V	
I_O	Output source current (continuous)	-50	mA	
T_S	Storage temperature range	-55 to +150	°C	
T_J	Maximum junction temperature	Ceramic Package	+165	°C
		Plastic Package	+150	°C

NOTE:

Operation beyond the limits set forth in this table may impair the useful life of the device. Unless otherwise noted, these limits are specified over the operating ambient temperature range.

DC OPERATING CONDITIONS

SYMBOL	PARAMETER	TEST CONDITIONS	LIMITS			UNIT
			MIN.	NOM.	MAX.	
V_{CC1}, V_{CC2}	Circuit ground		0	0	0	V
V_{EE}	Supply voltage (negative)			-5.2		V
V_{IH}	High level input voltage	$T_A = -30^\circ\text{C}$			-890	mV
		$T_A = +25^\circ\text{C}$			-810	mV
		$T_A = +85^\circ\text{C}$			-700	mV
V_{iHT}	High level input threshold voltage	$T_A = -30^\circ\text{C}$	-1205			mV
		$T_A = +25^\circ\text{C}$	-1105			mV
		$T_A = +85^\circ\text{C}$	-1035			mV
V_{iLT}	Low level input threshold voltage	$T_A = -30^\circ\text{C}$			-1500	mV
		$T_A = +25^\circ\text{C}$			-1475	mV
		$T_A = +85^\circ\text{C}$			-1440	mV
V_{iL}	Low level input voltage	$T_A = -30^\circ\text{C}$	-1890			mV
		$T_A = +25^\circ\text{C}$	-1850			mV
		$T_A = +85^\circ\text{C}$	-1825			mV
T_A	Operating ambient temperature range		-30	+25	+85	°C

NOTE:

When operating at other than the specified V_{EE} voltage (-5.2V), the DC and AC Electrical Characteristics will vary slightly from specified values.

Parity Checker/Generator

10160

DC ELECTRICAL CHARACTERISTICS $V_{CC1} = V_{CC2} = \text{ground}$, $V_{EE} = -5.2V \pm 0.010V$, $T_A = -30^\circ\text{C}$ to $+85^\circ\text{C}$ output loading 50Ω to $-2.0V \pm 0.010V$ unless otherwise specified^{1,3}

SYMBOL	PARAMETER		TEST CONDITIONS ²		LIMITS			UNIT
					MIN.	TYP.	MAX.	
V_{OH}	High level output voltage		$T_A = -30^\circ\text{C}$	Apply V_{IHMAX} to each input, one at a time with V_{ILMIN} applied to all other inputs.	-1060		-890	mV
			$T_A = +25^\circ\text{C}$		-960		-810	mV
			$T_A = +85^\circ\text{C}$		-890		-700	mV
V_{OHT}	High level output threshold voltage		$T_A = -30^\circ\text{C}$	Apply V_{IHT} to each input, one at a time with V_{ILMIN} applied to all other inputs.	-1080			mV
			$T_A = +25^\circ\text{C}$		-980			mV
			$T_A = +85^\circ\text{C}$		-910			mV
V_{OLT}	Low level output threshold voltage		$T_A = -30^\circ\text{C}$	Apply V_{ILT} to each input, one at a time with V_{ILMIN} applied to all other inputs.			-1655	mV
			$T_A = +25^\circ\text{C}$				-1630	mV
			$T_A = +85^\circ\text{C}$				-1595	mV
V_{OL}	Low level output voltage		$T_A = -30^\circ\text{C}$	Apply V_{IHMAX} to all inputs or apply V_{ILMIN} to all inputs.	-1890		-1675	mV
			$T_A = +25^\circ\text{C}$		-1850		-1650	mV
			$T_A = +85^\circ\text{C}$		-1825		-1615	mV
I_{IH}	High level input current	Input pins 3, 6, 7, 11 12, 15	$T_A = -30^\circ\text{C}$	Apply V_{IHMAX} to each input under test, one at a time, with V_{ILMIN} applied to all other inputs.			425	μA
			$T_A = +25^\circ\text{C}$				265	μA
			$T_A = +85^\circ\text{C}$				265	μA
		Other inputs	$T_A = -30^\circ\text{C}$				350	μA
			$T_A = +25^\circ\text{C}$				220	μA
			$T_A = +85^\circ\text{C}$				220	μA
I_{IL}	Low level input current		$T_A = -30^\circ\text{C}$	Apply V_{ILMIN} to each input under test, one at a time, with V_{IHMAX} applied to all other inputs.	0.5			μA
			$T_A = +25^\circ\text{C}$		0.5			μA
			$T_A = +85^\circ\text{C}$		0.3			μA
$-I_{EE}$	V_{EE} supply current		$T_A = -30^\circ\text{C}$	Apply V_{IHMAX} to input pins 4, 5, 9, 10, 13, 14 and V_{ILMIN} to all other pins.			86	mA
			$T_A = +25^\circ\text{C}$			62	78	mA
			$T_A = +85^\circ\text{C}$				86	mA
$\frac{\Delta V_{OH}}{\Delta V_{EE}}$	High level output voltage compensation		$T_A = +25^\circ\text{C}$			0.016		V/V
$\frac{\Delta V_{OL}}{\Delta V_{EE}}$	Low level output voltage compensation					0.250		V/V
$\frac{\Delta V_{BB}}{\Delta V_{EE}}$	Reference bias voltage compensation					0.148		V/V

NOTES:

- The specified limits represent the worst case values for the parameter. Since these worst case values normally occur at the supply voltage and temperature extremes, additional noise immunity can be achieved by decreasing the allowable operating condition ranges.
- Conditions for testing shown in the tables are not necessarily worst case. For worst case testing guidelines, refer to DC Testing, Chapter 1, Section 3.
- The specified limits shown in the DC Electrical Characteristics table can be met only after thermal equilibrium has been established. Thermal equilibrium is established by applying power for at least 2 minutes, while maintaining transverse airflow of 2.5 meters/sec (500 linear feet/min) over the device, mounted either in a test socket or on a printed circuit board. Test voltage values are given in the DC Operating Conditions table.

Parity Checker/Generator

10160

AC ELECTRICAL CHARACTERISTICS $V_{CC1} = V_{CC2} = \text{ground}, V_{EE} = -5.2V \pm 0.010V$

SYMBOL	PARAMETER	TEST CONDITIONS	LIMITS						UNIT	
			$T_A = -30^\circ\text{C}$		$T_A = +25^\circ\text{C}$			$T_A = +85^\circ\text{C}$		
			MIN.	MAX.	MIN.	TYP.	MAX.	MIN.		MAX.
t_{PLH} t_{PHL}	Propagation delay $A_0 - A_{11}$ to Q_n	Waveform 1	1.80	8.10	2.00	5.00	7.50	2.00	8.00	ns
			1.80	8.10	2.00	5.00	7.50	2.00	8.00	ns
t_{TLH} t_{THL}	Transition time 20% to 80%, 80% to 20%		1.10	3.50	1.10	2.00	3.30	1.00	3.50	ns
			1.10	3.50	1.10	2.00	3.30	1.00	3.50	ns

NOTE:

For AC test setup information, see AC Testing, Chapter 2, Section 3.

AC WAVEFORMS

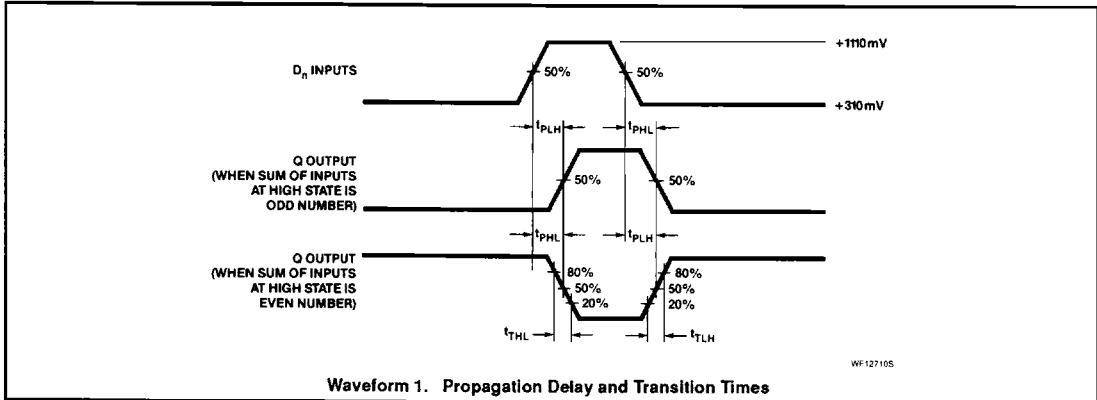

Waveform 1. Propagation Delay and Transition Times