

## Bulk Metal<sup>®</sup> Foil Technology

# Precision Trimming Potentiometers, 3/8 Inch Square, RJ24 Style, Designed to Meet or Exceed The Requirements of Mil-PRF-39035, Char. H

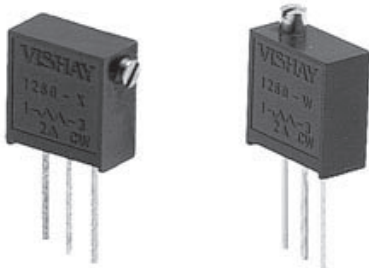

Product may not be to scale

### FEATURES

- Temperature Coefficient of Resistance (TCR):  $\pm 10\text{ppm}/^\circ\text{C}$ . ( $-55^\circ\text{C}$  to  $+150^\circ\text{C}$  Ref. @  $+25^\circ\text{C}$ ); Through the wiper<sup>3</sup>;  $\pm 25\text{ppm}/^\circ\text{C}$  (see table 2 for low values)
- Load Life Stability: 0.1% Typical  $\Delta R$ , 1.0% Maximum  $\Delta R$  under Full Rated Power @  $+85^\circ\text{C}$  for 10,000 hours
- Settability: 0.05% Typical; 0.1% Maximum
- Setting Stability: 0.1% Typical; 0.5% Maximum,  $\Delta SS$
- Power Rating: 0.25 watts @  $+85^\circ\text{C}$
- Resistance Range:  $5\Omega$  to  $10\text{K}\Omega$
- Resistance Tolerance:  $\pm 5\%$ ,  $\pm 10\%$

**TABLE 1 - MODEL SELECTION\***

MODEL	TERMINATION STYLE	AVERAGE WEIGHT (g)	STANDARD RESISTANCE VALUES (in $\Omega$ )	STANDARD TOLERANCE	POWER RATING @ $+85^\circ\text{C}$ AMBIENT	NO. OF TURNS
1260	W-Edge Mount, Top Adjust	0.4	5, 10	$\pm 10\%$	0.25 W	$21 \pm 2$
	X-Edge Mount, Side Adjust		20, 50, 100, 200, 500, 1K, 2K, 5K, 10K	$\pm 5\%$		

\*See Figure 1, next page..

**TABLE 2 - 1260 (RJ24) SERIES ELECTRICAL SPECIFICATIONS<sup>1</sup>**

Temperature Coefficient of Resistance (TCR) 50 $\Omega$ to 10K End-to-End <sup>2</sup>	$\pm 10\text{ppm}/^\circ\text{C}$ Maximum ( $-55^\circ\text{C}$ to $+25^\circ\text{C}$ ) $\pm 10\text{ppm}/^\circ\text{C}$ Maximum ( $+25^\circ\text{C}$ to $+150^\circ\text{C}$ )
Temperature Coefficient of Resistance 5, 10 and 20 $\Omega$	$\pm 20\text{ppm}/^\circ\text{C}$
Through the Wiper <sup>3</sup>	$\pm 25\text{ppm}/^\circ\text{C}$
Stability Load Life @ 10,000 Hours	0.1% Typical $\Delta R$ 1.0% Maximum $\Delta R$ (Under Full Rated Power of 0.25 watts @ $+85^\circ\text{C}$ )
Power Rating <sup>4</sup>	0.25 watts @ $+85^\circ\text{C}$
Settability	0.05% Typical; 0.1% Maximum
Setting Stability	0.1% Typical; 0.5% Maximum $\Delta SS$
Contact Resistance Variation – CRV (noise) <sup>5</sup>	3 $\Omega$ Typical 10 $\Omega$ Maximum
Hop-off	0.25% Typical; 1.0% Maximum
High-Frequency Operation Rise/Decay Time Inductance Capacitance	To 100MHz 10ns @ 1K $\Omega$ 0.08 $\mu\text{H}$ Typical 0.5pF Typical
Operating Temperature Range	$-55^\circ\text{C}$ to $+150^\circ\text{C}$

Refer to last page in this data sheet for footnotes.

**TABLE 3 MECHANICAL SPECIFICATIONS**

Adjustment Turns	$21 \pm 2$
Mechanical Stops	Wiper Idles – No Discontinuity
Internal Terminations	All Welded – No Flux
Case Material	Diallyl-Phthalate: Black (DAP)
Shaft Torque	3 oz. in. Maximum
Backlash	0.005% Typical

**TABLE 4 - ORDERING INFORMATION - 1260 SERIES PARTS**

Please specify Vishay Model 1260 Precision Trimming Potentiometers as follows:			
Example:			
1260	W	100R	5%
MODEL NO.	TERMINATION STYLE	RESISTANCE	TOLERANCE VALUE

See Table 1 for details.

See Figure 1, next page for Standard Marking designation.

**FIGURE 1 - SCHEMATIC AND DIMENSIONS** in inches (millimeters)

**1260W**

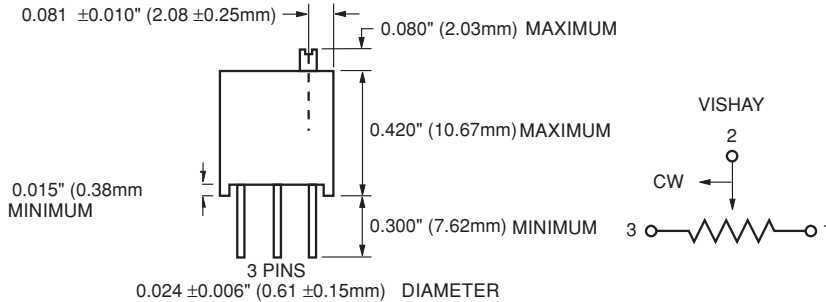

**STANDARD MARKING**

Model No.  
Date Code  
Resistance Value  
Tolerance

**NOTES**

Adjustment screw 0.090 Inches (2.30mm) diameter with 0.020 Inches (0.51mm) x 0.031 Inches (0.80mm) slot. Model 1268 has solder plated copper terminal pins. 0.024 inches (0.61mm) diameter, 0.300 Inches (7.62mm) length minimum.

**1260X**

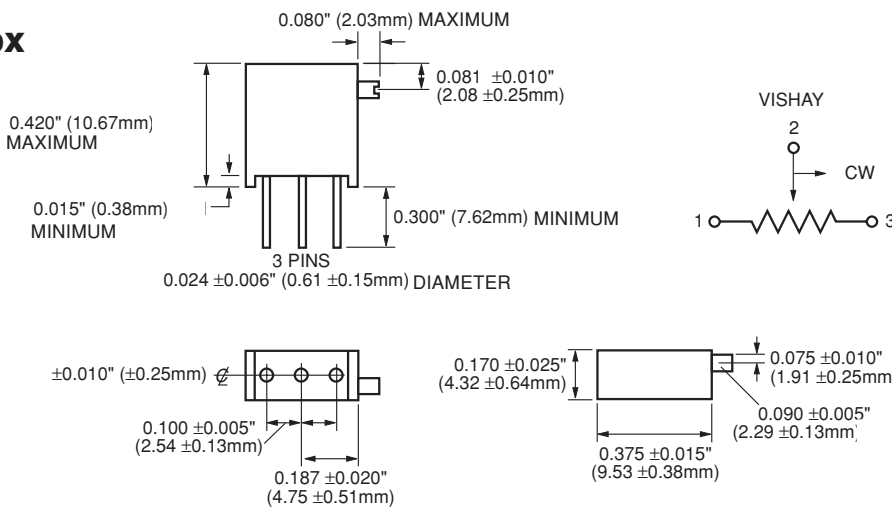

TRIMMERS

**FIGURE 2 - POWER DERATING CURVE**

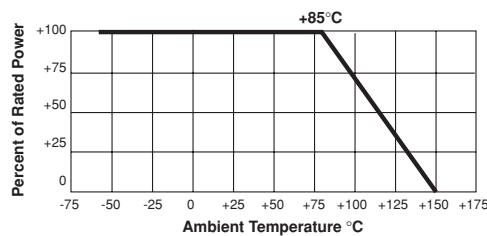



TABLE 5 - COMPARISON		
	MIL-PRF-39035/3 CHARACTERISTIC H <sup>6</sup>	1260 MAXIMUM (Worst Case)
<b>TEST GROUP I</b> Conditioning Contact Resistance Variation – CRV (noise) Immersion	± 1.0 % ± 3.0% or 3Ω <sup>7</sup> No continuous stream of bubbles	± 0.5 % 3Ω Typical, 10Ω Maximum No continuous stream of bubbles
<b>TEST GROUP Ia</b> Visual and Mechanical Actual Effective Electrical Travel End Resistance  Dielectric Withstanding Voltage – DWV (Atmospheric and Barometric Pressure) Insulation Resistance Shaft Torque Thermal Shock Setting Stability	No Failures 10 to 25 turns 2% or 2Ω <sup>7</sup>  Per MIL-Std-202, Methods 301 and 105  ≥ 1000 Megohms 3oz. in. Maximum ± 1.0% ± 1.0%	No Failures 21 ± 2 Turns 2Ω for Values ≤ 1KΩ; 5Ω for Values ≥ 2KΩ; Per MIL-Std-202, Methods 301 and 105  > 1000 Megohms 3oz. in. Maximum ± 0.5% ± 0.5%
<b>TEST GROUP II</b> Solderability	Per MIL-Std-202, Method 208	Per MIL-Std-202, Method 208
<b>TEST GROUP III</b> Resistance Temperature Characteristic – TCR Moisture Resistance Contact Resistance Variation – CRV (noise)	± 0.005% (± 50ppm/°C) ± 1.0% 3.0% or 3Ω <sup>7</sup>	± 0.001% (± 10ppm/°C) ± 0.5% 3Ω Typical, 10Ω Maximum
<b>TEST GROUP IV</b> Settability Shock Setting Stability Vibration Setting Stability Contact Resistance Variation – CRV (noise) Salt Spray	± 1.0% ± 1.0% ± 1.0% ± 1.0% ± 1.0% 3.0% or 3Ω <sup>7</sup> No Corrosion	± 0.1% ± 0.5% ± 0.5% ± 0.5% ± 0.5% 3Ω Typical, 10Ω Maximum No Corrosion
<b>TEST GROUP V</b> Solder Heat Low-Temperature Operation Setting Stability Low-Temperature Storage High-Temperature Exposure Setting Stability Contact Resistance Variation – CRV (noise) Integrity of Shaft	± 1.0% ± 1.0% ± 2.0% ± 1.0% ± 3.0% ± 2.0% 3.0% or 3Ω <sup>7</sup> No Loosening or Breakage	± 0.1% ± 0.5% ± 0.5% ± 0.5% ± 0.5% ± 0.5% 3Ω Typical, 10Ω Maximum No Loosening or Breakage
<b>TEST GROUP VI</b> Rotational Life (200 Cycles) Contact Resistance Variation – CRV (noise) Terminal Strength	± 2.0% 3.0% or 3Ω <sup>7</sup> 2lbs.	± 2.0% 3Ω Typical, 10Ω Maximum 2lbs.
<b>TEST GROUP VII</b> Life (2,000 Hours) @ + 85°C Life (10,000 Hours) @ + 85°C	± 3.0% ± 5.0%	± 0.1% Typical, ± 1.0% Maximum ± 0.1% Typical, ± 1.0% Maximum
<b>TEST GROUP VIII</b> Solvent Resistance	No Failures	No Failures

VISHAY TRIMMERS ARE INSPECTED 100% For:

- Short-time overload (6.25 x rated power for 5 seconds on; and for 30 seconds off – 3 cycles)
- Immersion
- Resistance tolerance check
- End Resistance
- Visual-Mechanical
- Dynamic tests for Continuity, CRV

By Sample For:

- TCR
- DWV

**NOTES:**

1. Maximum is 1.0% A.Q.L. standard for all specifications except TCR. (For TCR information, see notes 2 and 3.) "Typical" is a designers reference which represents that 85% of the lots supplied, over a long period of time, will be at least the figure stated or better.
2. Maximum TCR applies to the 3σ (sigma) limit or 99.73% of a production lot. (Measured end-to-end with wiper off the element.)
3. Measurements of TCR through the wiper are influenced more by setting stability and the percentage of the total resistance in use (at the wiper) than by fundamental resistance change due to temperature alone. The parameter shown in Table 2 is a 2σ distribution typifying the behavior of the device when used with 40% or more of the total resistance in use.
4. Derated linearly from full power @ + 85°C to zero (0) watts @ + 150°C. See Figure 2 on previous page.
5. Independent of resistance value. 3 ohms maximum available on special request.
6. All ΔR's are measured to the tolerance specified + 0.01 ohms
7. Whichever is greater.

Special Available Options:  
Special marking  
Burn-in and screening operations

VISHAY FOIL • FRANCE +33.4.93.37.28.24 FAX: +33.4.93.37.27.31 • ITALY + 39.2.300.11919 FAX: +39.2.300.11999 • SWEDEN +46.8.594.70590 FAX: +46.8.594.70581  
• GERMANY +49.9287.710 FAX: +49.9287.70435 • JAPAN +81.42.729.0661 FAX: +81.42.729.3400 • UK +44 191 514 8237 FAX: +44 1953 457 722  
• ISRAEL +972.3.557.0945 FAX: +972.3.558.9121 • SINGAPORE +65.788.6668 FAX: +65.788.0988 • USA +1 610 407-4800 FAX: +1 610 640-9081

TRIMMERS



## Notice

Specifications of the products displayed herein are subject to change without notice. Vishay Intertechnology, Inc., or anyone on its behalf, assumes no responsibility or liability for any errors or inaccuracies.

Information contained herein is intended to provide a product description only. No license, express or implied, by estoppel or otherwise, to any intellectual property rights is granted by this document. Except as provided in Vishay's terms and conditions of sale for such products, Vishay assumes no liability whatsoever, and disclaims any express or implied warranty, relating to sale and/or use of Vishay products including liability or warranties relating to fitness for a particular purpose, merchantability, or infringement of any patent, copyright, or other intellectual property right.

The products shown herein are not designed for use in medical, life-saving, or life-sustaining applications. Customers using or selling these products for use in such applications do so at their own risk and agree to fully indemnify Vishay for any damages resulting from such improper use or sale.