

LED870L

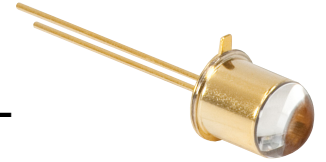

Description

The LED870L is an AlGaAs LED mounted in a hermetically sealed TO-18 package with a spherical glass lens. It is designed for a relatively narrow viewing angle.

Specifications

Absolute Max Ratings			
Specification	Max		
Reverse Voltage	5 V		
DC Forward Current	75 mA		
Pulsed Forward Current ^a	100 mA		
Operating Case Temperature	-30 to 80 °C		
Storage Temperature	-30 to 100 °C		
Specifications ^b			
	Min	Typical	Max
Operating Current (Continuous)	-	50 mA	75 mA
Forward Voltage at 50 mA	-	1.5 V	1.8 V
Optical Output Power at 50 mA	-	24 mW	-
Viewing Half Angle	-	13°	-
Peak Wavelength	850 nm	870 nm	890 nm
Bandwidth (FWHM)	-	42 nm	-



- a. Pulsed Forward Current Condition: Duty Cycle = 1% and Pulse Width = 10 μ s.
- b. Unless otherwise specified, all specifications are for operation at 25 °C.

Soldering Specifications	
	Conditions
Dip Soldering	Pre-Heat Backside of PCB at 90 °C Maximum for 60 Seconds or Less; Solder Bath at 250 °C Maximum for 5 Seconds or Less
Hand Soldering	Soldering Iron Tip at 250 °C Maximum for 3 Seconds or Less

Cleaning Solvents						
Solvent	Ethyl Alcohol	Isopropyl Alcohol	Propanol	Acetone	Trichloroethylene	MKS
Approved	Yes	Yes	Yes	Yes	No	No

Typical Performance Plots

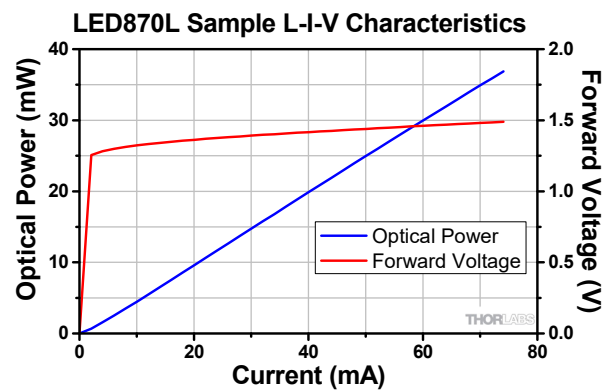
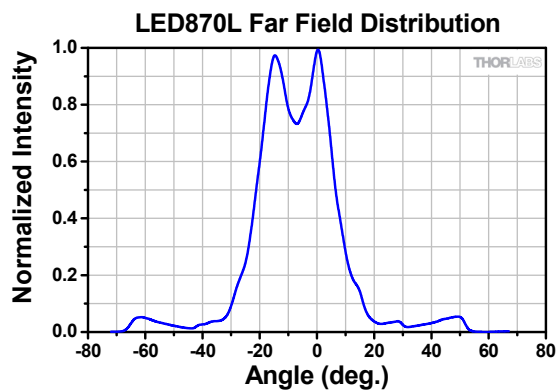
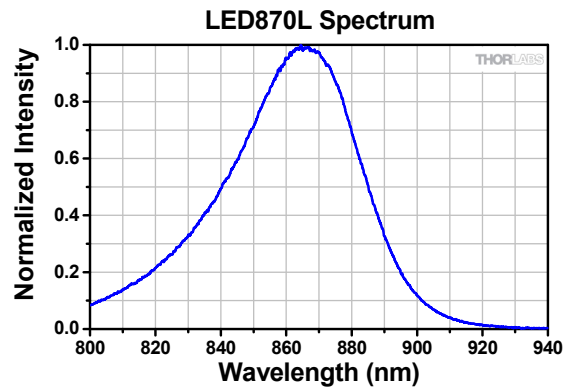

These measurements were taken at a case temperature of 25 °C. The output spectrum and radiation distribution were measured with an operating current of 50 mA.

Drawing

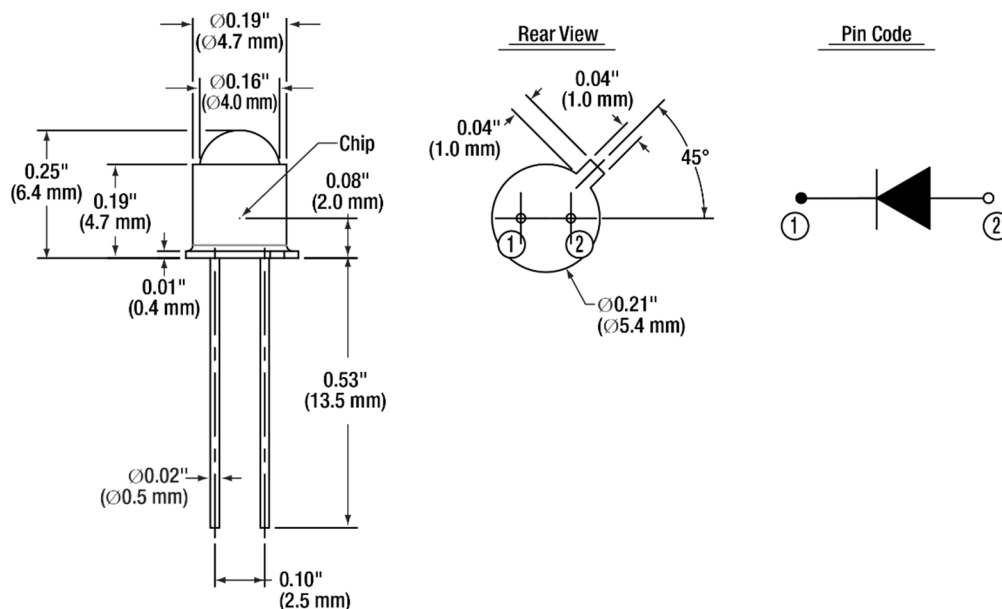

Precautions and Warranty Information

These products are ESD (electro static discharge) sensitive and as a result are not covered under warranty. In order to ensure the proper functioning of an LED care must be given to maintain the highest standards of compliance to the maximum electrical specifications when handling such devices. The LEDs are particularly sensitive to any voltage that exceeds the absolute maximum ratings of the product. Any applied voltage in excess of the maximum specification will cause damage and possible complete failure to the product. The user must use handling procedures that prevent any electro static discharges or other voltage surges when handling or using these devices.