

SMB3100D-9316

SMB Plug Crimp Right Angle 50Ω

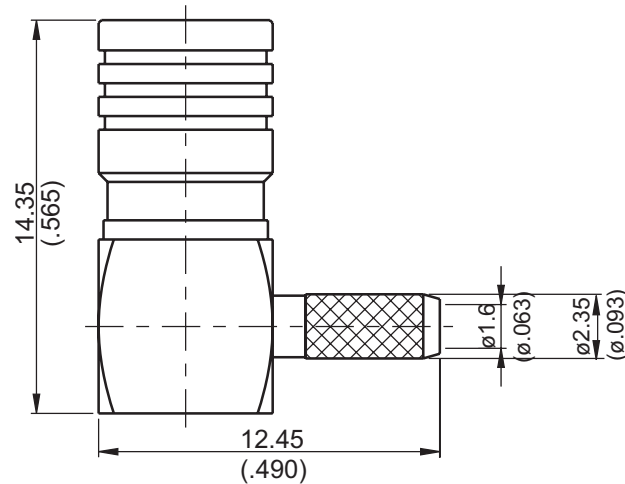

Parts	Material	Plating (Micro-inch)
Cover	Brass	Gold 5 Over Nickel 50 Over Copper 50
Ferrule	Brass	Gold 5 Over Nickel 50 Over Copper 50
Retainer Ring	Beryllium Copper	Tin-Zinc-Copper-Alloy 100 Over Copper 50
Contact Pin	Beryllium Copper	Gold 20 Over Nickel 50 Over Copper 50
Insulator	Teflon	
Body	Brass	Gold 5 Over Nickel 50 Over Copper 50
Barrel	Brass	Gold 5 Over Nickel 50 Over Copper 50
Coupling Nut	Brass	Gold 5 Over Nickel 50 Over Copper 50

Weight: 3.10 g

Suitable Cables: RD316, RG316D-E, RD316-FEP, JBY100

This part number complies with RoHS.

Notice: JYEBAO reserves the right to make modifications deemed appropriate.

CABLE ASSEMBLY INSTRUCTION

SMB3100D-9316

JYE BAO CO., LTD.

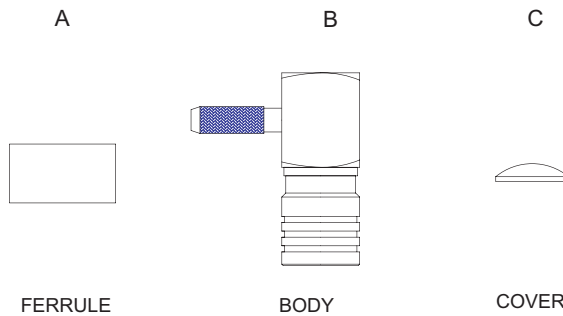

DIAGRAM	ASSEMBLY INSTRUCTION
	<p>Step 1: STRIP AS SHOWN.</p>
	<p>Step 2: SLIDE FERRULE "A" OVER CABLE. Step 3: WRAP THE BRAIDING UPWARDS. Step 4: SLIDE CENTER CONDUCTOR ON THE CONTACT PIN OF CONNECTOR "B" AND SOLDER IN "Y".</p>
	<p>Step 5: SLIDE FERRULE "A" TOWARDS THE CONNECTOR "B" AND CRIMP.</p>
	<p>Step 6: PRESS ON THE TOP OF "C" WITH JIGS AS SHOWN.</p>

This part number complies with RoHS.

Notice: JYEBAO reserves the right to make modifications deemed appropriate.