

1.1 Overview

The MN103LF series of 32-bit single-chip microcomputers have multiple types of peripheral functions. This LSI series is well suited for camera, TV, VCR, Car audio, printer, telephone, FAX machine, air-conditioner, music instrument and other applications.

This LSI series has flexible and optimized hardware configurations and simple efficient instruction set. This LSI series incorporates an internal ROM of 1048 KB (maximum) and RAM of 96 KB (maximum), 22 external interrupts, 132 internal interrupts including non-maskable interrupt, 30 timer counters, 20 sets of serial interfaces, A/D converter, D/A converter, 2 sets of watchdog timer, DMA, CAN, and IEBus interface.

In addition, this LSI series has 5 oscillation circuits (external high frequency: 4 MHz to 20 MHz/ external low frequency: 32.768 kHz/ internal high frequency: 20 MHz/ internal low frequency: 30 kHz/ PLL: frequency multiplier of high or low frequency).

The internal clock can be switched to 5 oscillation clock except the internal low oscillation. The internal clock is generated by dividing the oscillation clock or PLL clock. The best operation clock for the system can be selected by switching its frequency ratio by programming.

A machine cycle (minimum instruction execution time) is 20.8 ns (internal operating condition: 1.8 V, 48 MHz).

1.2 Product Summary

This manual describes the following model.

Series *1	Model	Pin Number	ROM Size	RAM Size *2	In-vehicle LAN	Package	
MN103LF40/ MN103LF44	MN103LF44R *	100 pin	1048 KB	96 KB	IEBus	100 pin LQFP(14 mm × 14 mm/ 0.5mm pitch)	
	MN103LF44Q *		792 KB				
	MN103LF40R *		1048 KB	76 KB			
	MN103LF40Q *		792 KB				
	MN103LF40N *		536 KB	40 KB			
	MN103LF40M *		408 KB	32 KB			
	MN103LF40K *		280 KB	20 KB			
MN103LF41/ MN103LF45	MN103LF45R *	128 pin	1048 KB	96 KB		IEBus	128 pin LQFP(18 mm × 18 mm/ 0.5mm pitch)
	MN103LF45Q *		792 KB				
	MN103LF41R *		1048 KB	76 KB			
	MN103LF41Q *		792 KB				
	MN103LF41N *		536 KB	40 KB			
	MN103LF41M *		408 KB	32 KB			
	MN103LF41K *		280 KB	20 KB			
MN103LF42/ MN103LF46	MN103LF46R *	144 pin	1048 KB	96 KB	IEBus		144 pin LQFP(20 mm × 20 mm/ 0.5mm pitch)
	MN103LF46Q *		792 KB				
	MN103LF42R *		1048 KB	76 KB			
	MN103LF42Q *		792 KB				
	MN103LF42N *		536 KB	40 KB			
	MN103LF42M *		408 KB	32 KB			
	MN103LF42K *		280 KB	20 KB			
MN103LF43/ MN103LF47	MN103LF47R *	176 pin	1048 KB	96 KB		IEBus	176 pin LQFP(24 mm × 24 mm/ 0.5mm pitch)
	MN103LF47Q *		792 KB				
	MN103LF43R *		1048 KB	76 KB			
	MN103LF43Q *		792 KB				
	MN103LF43N *		536 KB	40 KB			
	MN103LF43M *		408 KB	32 KB			
	MN103LF43K *		280 KB	20 KB			

Series *1	Model	Pin Number	ROM Size	RAM Size *2	In-vehicle LAN	Package
MN103LF48/ MN103LF52	MN103LF52R *	100 pin	1048 KB	96 KB	CAN	100 pin LQFP(14 mm × 14 mm/ 0.5mm pitch)
	MN103LF52Q *		792 KB			
	MN103LF48R *		1048 KB	76 KB		
	MN103LF48Q *		792 KB			
	MN103LF48N *		536 KB	40 KB		
	MN103LF48M *		408 KB	32 KB		
	MN103LF48K *		280 KB	20 KB		
MN103LF49/ MN103LF53	MN103LF53R *	128 pin	1048 KB	96 KB		128 pin LQFP(18 mm × 18 mm/ 0.5mm pitch)
	MN103LF53Q *		792 KB			
	MN103LF49R *		1048 KB	76 KB		
	MN103LF49Q *		792 KB			
	MN103LF49N *		536 KB	40 KB		
	MN103LF49M *		408 KB	32 KB		
	MN103LF49K *		280 KB	20 KB		
MN103LF50/ MN103LF54	MN103LF54R *	144 pin	1048 KB	96 KB		144 pin LQFP(20 mm × 20 mm/ 0.5mm pitch)
	MN103LF54Q *		792 KB			
	MN103LF50R *		1048 KB	76 KB		
	MN103LF50Q *		792 KB			
	MN103LF50N *		536 KB	40 KB		
	MN103LF50M *		408 KB	32 KB		
	MN103LF50K *		280 KB	20 KB		
MN103LF51/ MN103LF55	MN103LF55R *	176 pin	1048 KB	96 KB	176 pin LQFP(24 mm × 24 mm/ 0.5mm pitch)	
	MN103LF55Q *		792 KB			
	MN103LF51R *		1048 KB	76 KB		
	MN103LF51Q *		792 KB			
	MN103LF51N *		536 KB	40 KB		
	MN103LF51M *		408 KB	32 KB		
	MN103LF51K *		280 KB	20 KB		

Series *1	Model	Pin Number	ROM Size	RAM Size *2	In-vehicle LAN	Package		
MN103LF56/ MN103LF60	MN103LF60R *	100 pin	1048 KB	96 KB	-	100 pin LQFP(14 mm × 14 mm/ 0.5mm pitch)		
	MN103LF60Q *		792 KB					
	MN103LF56R *		1048 KB	76 KB				
	MN103LF56Q *		792 KB					
	MN103LF56N *		536 KB	40 KB				
	MN103LF56M *		408 KB	32 KB				
	MN103LF56K *		280 KB	20 KB				
MN103LF57/ MN103LF61	MN103LF61R *	128 pin	1048 KB	96 KB		-	128 pin LQFP(18 mm × 18 mm/ 0.5mm pitch)	
	MN103LF61Q *		792 KB					
	MN103LF57R *		1048 KB	76 KB				
	MN103LF57Q *		792 KB					
	MN103LF57N *		536 KB	40 KB				
	MN103LF57M *		408 KB	32 KB				
	MN103LF57K *		280 KB	20 KB				
MN103LF58/ MN103LF62	MN103LF62R *	144 pin	1048 KB	96 KB	-		144 pin LQFP(20 mm × 20 mm/ 0.5mm pitch)	
	MN103LF62Q *		792 KB					
	MN103LF58R *		1048 KB	76 KB				
	MN103LF58Q *		792 KB					
	MN103LF58N *		536 KB	40 KB				
	MN103LF58M *		408 KB	32 KB				
	MN103LF58K *		280 KB	20 KB				
MN103LF59/ MN103LF63	MN103LF63R *	176 pin	1048 KB	96 KB		-	176 pin LQFP(24 mm × 24 mm/ 0.5mm pitch)	
	MN103LF63Q *		792 KB					
	MN103LF59R *		1048 KB	76 KB				
	MN103LF59Q *		792 KB					
	MN103LF59N *		536 KB	40 KB				
	MN103LF59M *		408 KB	32 KB				
	MN103LF59K *		280 KB	20 KB				
MN103LF64	MN103LF64R *	144 pin	1048 KB	96 KB	CAN/IEBus		144 pin LQFP(20 mm × 20 mm/ 0.5mm pitch)	
	MN103LF64Q *		792 KB					
MN103LF65	MN103LF65R *	176 pin	1048 KB	96 KB			CAN/IEBus	176 pin LQFP(24 mm × 24 mm/ 0.5mm pitch)
	MN103LF65Q *		792 KB					

*1 Refer to [Chapter 37 Appendix] of LSI User's Manual for details.

*2 When using On-Chip Debug function, the debugger take over 500 Byte in size

* Under development

1.3 Hardware Functions

CPU core

MN103L core (The instruction set is compatible MN103S series)

Memory space 4 GB (instruct/data common use)

LOAD-STORE architecture (3-stage pipeline)

Machine cycle

High-speed mode 20.8 ns/ 48 MHz (Max)

Low-speed mode 30.5 μ s/ 32.768 kHz (Max)

Operation mode

NORMAL mode (CPU clock operation, Peripheral circuit clock operation mode)

SLOW mode (CPU clock operation, Peripheral circuit clock operation mode)

HALT mode (CPU clock stop, Peripheral circuit clock operation mode)

STOP mode (All clocks stop mode)

Clock oscillation circuit : 5 circuits

External high-speed oscillation (clkosc) : Crystal oscillator/ Ceramic oscillator
: 4 MHz to 20 MHz

External low-speed oscillation (clkx) : Crystal oscillator/ Ceramic oscillator
: 32.768 kHz

Internal high-speed oscillation (clkrc) : 20 MHz

Internal low-speed oscillation (clkrcx) : 30 kHz

PLL output (clkpll) : 60 MHz to 120 MHz

Clock multiple circuit (PLL)

Multiplication rate: 4, 6, 8, 10, 12, 16, 20 multiplied clock of clkoscsl
2440 to 3660 multiplied clock of clkx

Clock dividing 2, 3 divided of clkpll

PLL output dividing clock: 20 MHz to 48 MHz (clkplldiv)

Internal operation clock : 6 types

CPU clock (clkcpu)

- Frequency : 48 MHz (Max)
- Clock source : clkplldiv, clkosc, clkrc, clkx
- Clock dividing : 1, 2, 4, 8, 16, 32, 64 divided of clock source

Peripheral bus clock (clkbus)

- Frequency : 24 MHz (Max)
- Clock source : clkplldiv, clkosc, clkrc, clkx
- Clock dividing : 2, 4, 8, 16, 32, 64, 128 divided of clock source

(This setting is independent from the dividing clock setting of clkcpu.)

Set the frequency of clkbus to less than clkcpu.)

Peripheral high-speed clock (clksp)

- Frequency : 24 MHz (Max)
- Clock source : clkrc, clkosc, clkplldiv
- Clock dividing : 1, 2, 4, 8, 16 divided of clock source

High-speed oscillation clock (clkoscsel)

- Frequency : 22 MHz (Max)
- Clock source : clkrc, clkosc

Internal low-speed oscillation clock (clkrcx)

- Frequency : 33 kHz (Max)

Low-speed oscillation clock (clkx)

- Frequency : 39.0625 kHz (Max)
- Clock source : clkrcx, clkxsel

External bus interface

- Bus area : 2 MB × 2 banks
- Data bus : 8/ 16 bits

DMA Controller

Transfer area : Internal ROM space / Internal RAM space / Internal I/O area / External memory space
⇔ Internal ROM space / Internal RAM space / Internal I/O area / External memory space

Channel : 8 ch

Transfer form : 2 bus cycles transfer

Transfer requests

102 types

(External interrupts:16, Timer:36, Serial I/F:36, IIC: 8, A/D converter: 1,
CAN controller: 2 (*1), IEBus controller: 2 (*1), Software:1)

Transfer modes: 3 modes (One word transfer / Burst transfer / Intermittent transfer)

Interrupt functions

Internal interrupts

132 factors

(Timer: 51, Serial I/F: 24, IIC:16, Watchdog timer:2, Real time clock: 2, DMA:24,
A/D converter:1, LIN controller: 1, CAN controller: 2 (*1), IEBus controller: 4 (*1),
Power Voltage Detection: 2, Error detection of Clock monitoring function: 1,
Wrong writing detection of Register protect function: 1, System error:1)

External interrupts:

22 factor

(IRQn pin(n=0 to 15) :16, NMIRQ pin:1, Key input:5)



*1 CAN/IEBus factors can use only the product series which have the CAN/IEBus function.
Refer to Product Summary about the products which have CAN/IEBus functions.

Watchdog Timer

Watchdog Timer

On detection of error, hardware reset is done inside the LSI
(Non-maskable interrupt is generated by the first watchdog time-out event, and hardware reset is done by a series of two time-out events)

Time-out cycle : CPU clock cycle \times N (N = 2^{16} , 2^{18} , 2^{20} , 2^{27})

Watchdog Timer2

On detection of error, hardware reset is done inside the LSI
(Non-maskable interrupt is generated by the first watchdog time-out event, and hardware reset is done by a series of two time-out events)

Time-out cycle : Internal low-speed oscillation clock cycle \times N
(N = 2^4 , 2^5 , 2^6 , 2^7 , 2^8 , 2^9 , 2^{10} , 2^{11} , 2^{12} , 2^{13} , 2^{14} , 2^{15})

Timer counter : 30 units

8-bit timer : 8 units

8-bit simple timer : 5 units

8-bit free-running timer : 1 unit

16-bit timer : 13 units

Motor control 16-bit timer : 1 unit

24H 8-bit timer : 1 unit

Real time clock : 1 unit

Timer 0 to 4 (8-bit timer)

Timer count (Up count), external event count, timer pulse output,
PWM output (Cycle is fixed, Only timer 0, 2 and 4 can output), compare register with double buffer
16-bit cascade connection (At timer 0 and 1 connection, At timer 2 and 3 connection),
24-bit cascade connection (At timer 0, 1 and 2 connection),
32-bit cascade connection (At timer 0, 1, 2 and 3 connection)

Clock source : clksp, clksp/4, clksp/16, clksp/32, clksp/64, clksp/128,
clkbus/2, clkbus/4, clkbus/8, clkxs, external clock

Timer 20, 22 (8-bit timer)

Timer count (Up count), external event count, timer pulse output, PWM output (Cycle is fixed)

Clock source : clksp, clksp/4, clksp/16, clksp/32, clksp/64,
clkbus/2, clkbus/4, clkxs, external clock

Timer 21 (8-bit timer)

Timer count (Up count), timer pulse output, timer output for VFD

Clock source : clkbus, clkbus/2, clkbus/4, clkbus/8, clkbus/16, clkbus/32, clkbus/64, clkbus/128

Timer 6 (8-bit free-running timer)

Clock source : clksp, clkbus, clkxs, clksp/2¹², clksp/2¹³, clkxs/2¹², clkxs/2¹³

Timer 7, 17 to 19 (16-bit timer)

Timer count (Up count), external event count, timer pulse output,
PWM output (cycle/duty continuous changeable), input capture (1 system)

Clock source : clksp, clksp/2, clksp/4, clksp/16, clkbus, clkbus/2, clkbus/4,
clkbus/16, external clock

Timer 8 to 16 (16-bit timer)

Timer count (Up count, Down count), external event count, timer pulse output,
PWM output (cycle/duty continuous changeable), input capture (2 system),
2 phases encoder

Clock source : clkbus, clkbus/8, timer 0 or 1 compare match cycle, external clock

Timer M (Motor control 16-bit timer)

Timer pulse output, external event count,
complementary 3 phases PWM output (triangular wave and saw-tooth wave output,
dead time insertion),
output control by external interrupt (Hi-Z output or output data is fixed)

Clock source : clksp, clkbus, external clock divided by 1, 2, 4 or 16

Timer A, B, C, D, E (8-bit simple timer)

Serial transfer base clock generation

Clock source : clksp, clksp/2, clksp/4, clksp/8, clksp/16, clksp/32,
clkbus/2, clkbus/4

24H Timer

Alarm function, Interval function

Clock source : clk_{sx}, clksp (Only when CPU stop)

Real Time Clock

Calendar function (second, minute, hour, date, month, year are counted),
Alarm function, Cycle interrupt

Clock source : clk_x, clkosc

Serial interface : 20 channels

UART/ Clock Synchronous : 12 channels

IIC : 8 channels

Serial 0 (UART / Clock Synchronous / LIN)

- UART

Parity check, overrun error/frame error detection,
Transfer size can be selected from 7 to 8 bits.

- Clock Synchronous

The communication type can be selected from 2-wire or 3-wire.

First transfer bit can be selected from MSB or LSB.

Arbitrary size of 2 to 8 bits are selectable.

Continuous transmission, continuous reception, continuous transmission/reception are available.
Synchronous edge selection of transfer clock.

- LIN

Operate in conjunction with Timer 0, 7 and 8.

Master communication.

Synch Break field transmission, Check sum arithmetic

Slave communication

Wake-up reception, Synch Break field reception, Synch field reception, Check sum arithmetic

Error detection

Check sum error, Bit error

Maximum transfer rate: 3.3 Mbps

Clock source: Baud Rate Timer Bn output (n=1 to 4, 9, 10), external clock

Serial 1 to 4, 9, 10 (UART / Clock Synchronous)

- UART

Parity check, overrun error/frame error detection,

Transfer size can be selected from 7 to 8 bits.

- Clock Synchronous

The communication type can be selected from 2-wire or 3-wire.

First transfer bit can be selected from MSB or LSB.

Arbitrary size of 2 to 8 bits are selectable.

Continuous transmission, continuous reception, continuous transmission/reception are available.

Synchronous edge selection of transfer clock.

RST/CTS function

Maximum transfer rate: 3.3 Mbps

Clock source: Baud Rate Timer Bn output (n=1 to 4, 9, 10), external clock

Serial 11 (UART / Clock Synchronous)

- UART

Parity check, overrun error/frame error detection,

Transfer size can be selected from 7 to 8 bits.

- Clock Synchronous

The communication type can be selected from 2-wire or 3-wire.

First transfer bit can be selected from MSB or LSB.

Arbitrary size of 2 to 8 bits are selectable.

Continuous transmission, continuous reception, continuous transmission/reception are available.

Synchronous edge selection of transfer clock.

- SPI function

Chip select pin: 8 pins

Clock source: Baud Rate Timer B11 output, external clock

Maximum transfer rate: 10 Mbps

Serial 5, 6, 7, 8 (UART / Clock Synchronous)

- UART

Parity check, overrun error/frame error detection.
Transfer size can be selected from 7 to 8 bits.

- Clock Synchronous

The communication type can be selected from 2-wire or 3-wire.
(Data input from SBO pin is prohibited)
First transfer bit can be selected from MSB or LSB.
Continuous transmission, continuous reception, continuous transmission/reception are available.
Arbitrary size of 7 to 8 bits are selectable.
(When selection size is 7 bits, first transfer bit setting is LSB only.)

Maximum transfer rate: 3.3 Mbps

Clock source: Output of timer A, B, C, D, E divided by 2, 16, External clock

IIC 0 to 7 (Multi master IIC)

- Multi master IIC

100 kHz/ 400 kHz communication is supported.
7-bit, 10-bit slave address is settable.
General call communication mode is supported.

Clock source : Baud Rate Timer BIn output (n=0 to 7), external clock

A/D converter

Resolution : 10 bit

Channel : 32 channels

Clock source : clkbus/2, clkbus/4, clkbus/8, clkbus/16, clk_{sx} × 2

D/A converter

Resolution : 10-bit

Unit : 2 units

Auto reset

Auto reset function can be selected ON/OFF

Power supply voltage detection circuit

Detection voltage can be set 2.6 V to 4.0 V by software

Clock monitoring function

Frequency error detection of CPU clock when external / PLL clock is used as clock source

Hardware reset or non-maskable interrupt generation can be selected by program when a frequency error is detected.

CAN controller (*1)

Channels	: 2 channels CAN 2.0B specification basis
Communication method	: NRZ (Non-Return to Zero)
Transmission line	: 2-wire serial communication
Communication channel	: Max 1 Mbps
Data length	: 0 to 8 byte
Message frame	: Standard frame and extended frame are supported (Standard frame format ID: 11 bits Extended frame format ID: 29 bits)
Buffer size	: 136-bit × 32 (transmission / reception)

IEBus (*1)

Channels	: 2 channels
Communication mode	: Select from mode1 and mode2
Driver/receiver	: External



*1 CAN/IEBus factors can use only the product series which have the CAN/IEBus function.
Refer to Product Summary about the products which have CAN/IEBus functions.

CRC calculator function

Generator polynomial:

CRC-CCITT ($X^{16}+X^{12}+X^5+1$), CRC-8-ATM (X^8+X^2+X+1),
CRC-16 ($X^{16}+X^{15}+X^2+1$), CRC-12 ($X^{12}+X^{11}+X^3+X^2+X+1$),
CRC-32 ($X^{32}+X^{26}+X^{23}+X^{22}+X^{16}+X^{12}+X^{11}+X^{10}+X^8+X^7+X^5+X^4+X^2+X+1$)

Functions:

LSB first/MSB first selection, XOR calculator, Initial data setting

Port function

176 pins version

I/O ports	: 162 pins
CMOS I/O	: 118 pins
Combination CMOS I/O and oscillation pin	: 4 pins
Combination CMOS I/O and Analog I/O	: 32 pins
Combination CMOS I/O and LED driver	: 8 pins
Special function pin	: 5 pins
Reset input pin (NRST) (software reset is available)	: 1 pin
A/D converter reference voltage input pin (VREFH)	: 1 pin
Capacity connect pin (VOUT18)	: 1 pin
Function control pins (OCDMOD, ATRST)	: 2 pins
Power pins	: 9 pins
Power supply pin(VDD50)	: 3 pins
GND pins (VSS)	: 4 pins
Analog power supply pin(AVDD)	: 1 pins
Analog GND pins (AVSS)	: 1 pins

144 pins version

I/O ports	: 130 pins
CMOS I/O	: 86 pins
Combination CMOS I/O and oscillation pin	: 4 pins
Combination CMOS I/O and Analog I/O	: 32 pins
Combination CMOS I/O and LED driver	: 8 pins
Special function pin	: 5 pins
Reset input pin (NRST) (software reset is available)	: 1 pin
A/D converter reference voltage input pin (VREFH)	: 1 pin
Capacity connect pin (VOUT18)	: 1 pin
Function control pins (OCDMOD, ATRST)	: 2 pins
Power pins	: 9 pins
Power supply pin(VDD50)	: 3 pins
GND pins (VSS)	: 4 pins
Analog power supply pin(AVDD)	: 1 pins
Analog GND pins (AVSS)	: 1 pins

128 pins version

I/O ports	: 115 pins
CMOS I/O	: 71 pins
Combination CMOS I/O and oscillation pin	: 4 pins
Combination CMOS I/O and Analog I/O	: 32 pins
Combination CMOS I/O and LED driver	: 8 pins
Special function pin	: 5 pins
Reset input pin (NRST) (software reset is available)	: 1 pin
A/D converter reference voltage input pin (VREFH)	: 1 pin
Capacity connect pin (VOUT18)	: 1 pin
Function control pins (OCDMOD, ATRST)	: 2 pins
Power pins	: 7 pins
Power supply pin(VDD50)	: 2 pins
GND pins (VSS)	: 3 pins
Analog power supply pin(AVDD)	: 1 pins
Analog GND pins (AVSS)	: 1 pins

100 pins version

I/O ports	: 87 pins
CMOS I/O	: 43 pins
Combination CMOS I/O and oscillation pin	: 4 pins
Combination CMOS I/O and Analog I/O	: 32 pins
Combination CMOS I/O and LED driver	: 8 pins
Special function pin	: 5 pins
Reset input pin (NRST) (software reset is available)	: 1 pin
A/D converter reference voltage input pin (VREFH)	: 1 pin
Capacity connect pin (VOUT18)	: 1 pin
Function control pins (OCDMOD, ATRST)	: 2 pins
Power pins	: 7 pins
Power supply pin(VDD50)	: 2 pins
GND pins (VSS)	: 3 pins
Analog power supply pin(AVDD)	: 1 pins
Analog GND pins (AVSS)	: 1 pins

Package

176pin LQFP (24 mm × 24 mm / 0.5 mm pitch, halogen free)

144pin LQFP (20 mm × 20 mm / 0.5 mm pitch, halogen free)

128pin LQFP (18 mm × 18 mm / 0.5 mm pitch, halogen free)

100pin LQFP (14 mm × 14 mm / 0.5 mm pitch, halogen free)

Panasonic's "halogen free" semiconductor products refer to the products made of molding resin and interposer which conform to the following standards.

- Bromine : 900 ppm (Maximum Concentration Value)
- Chlorine : 900 ppm (Maximum Concentration Value)
- Bromine + Chlorine : 1500 ppm (Maximum Concentration Value)

The above-mentioned standards are based on the numerical value described in IEC61249-2-21. Antimony and its compounds are not added intentionally.

Power supply voltage

VDD50 : 2.2 V to 5.5 V

AVDD : AVDD=VDD50 (A/D converter or D/A converter is not used)
AVDD=VDD50≥2.7 V (A/D converter or D/A converter is used)

Operating temperature

-40 °C to +105 °C

1.4 Block Diagram

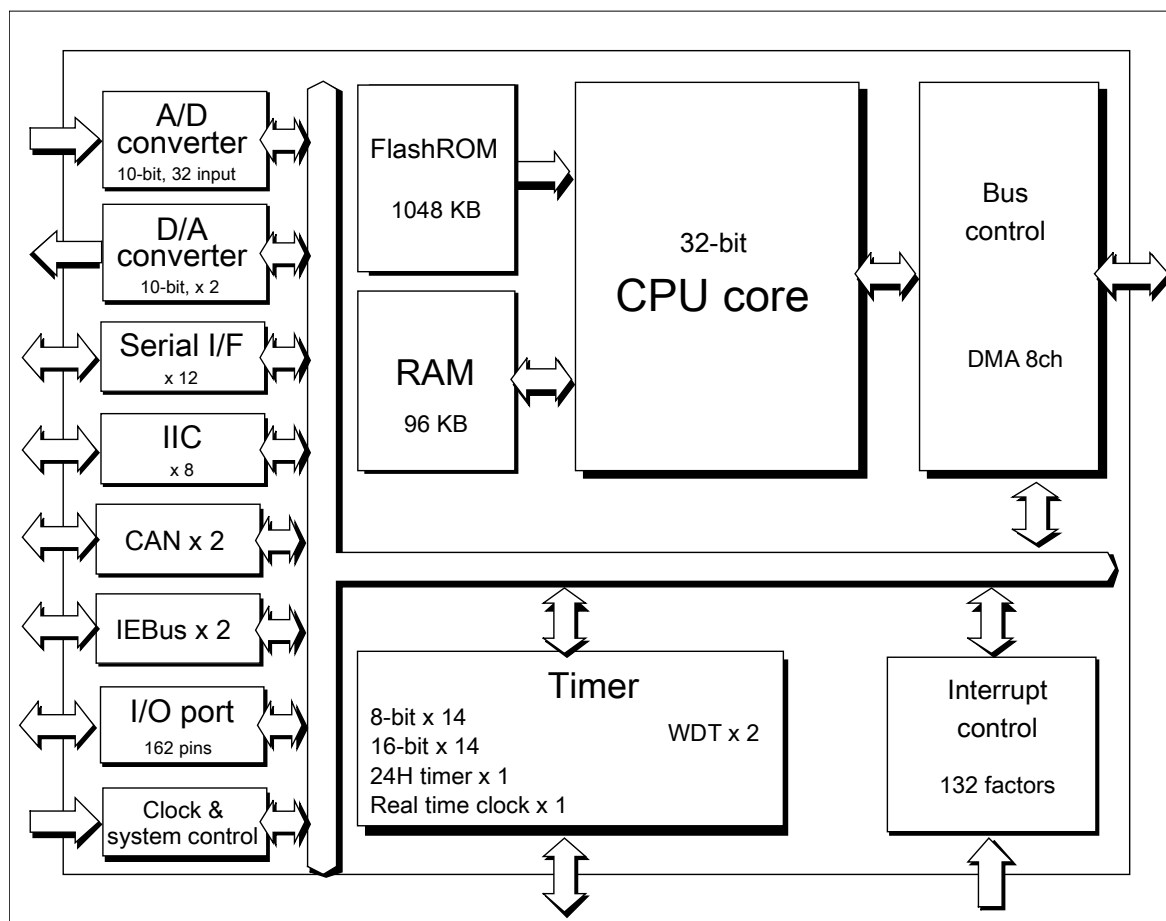

Figure:1.4.1 MN103LF40 Series Block Diagram



Functions in Figure:1.4.1 are different for each series. Refer to [1.3 Hardware Functions] for detail of each series.

1.5 Pin Specification

1.5.1 Pin Configuration

Figure:1.5.1 shows pin configuration of 176 pin version. Figure:1.5.2 shows pin configuration of 144 pin version. Figure:1.5.3 shows pin configuration of 128 pin version. Figure:1.5.4 shows pin configuration of 100 pin version. Table:1.5.1 shows pin specification of 176 pin version. Table:1.5.2 shows pin specification of 144 pin version. Table:1.5.3 shows pin specification of 128 pin version. Table:1.5.4 shows pin specification of 100 pin version.

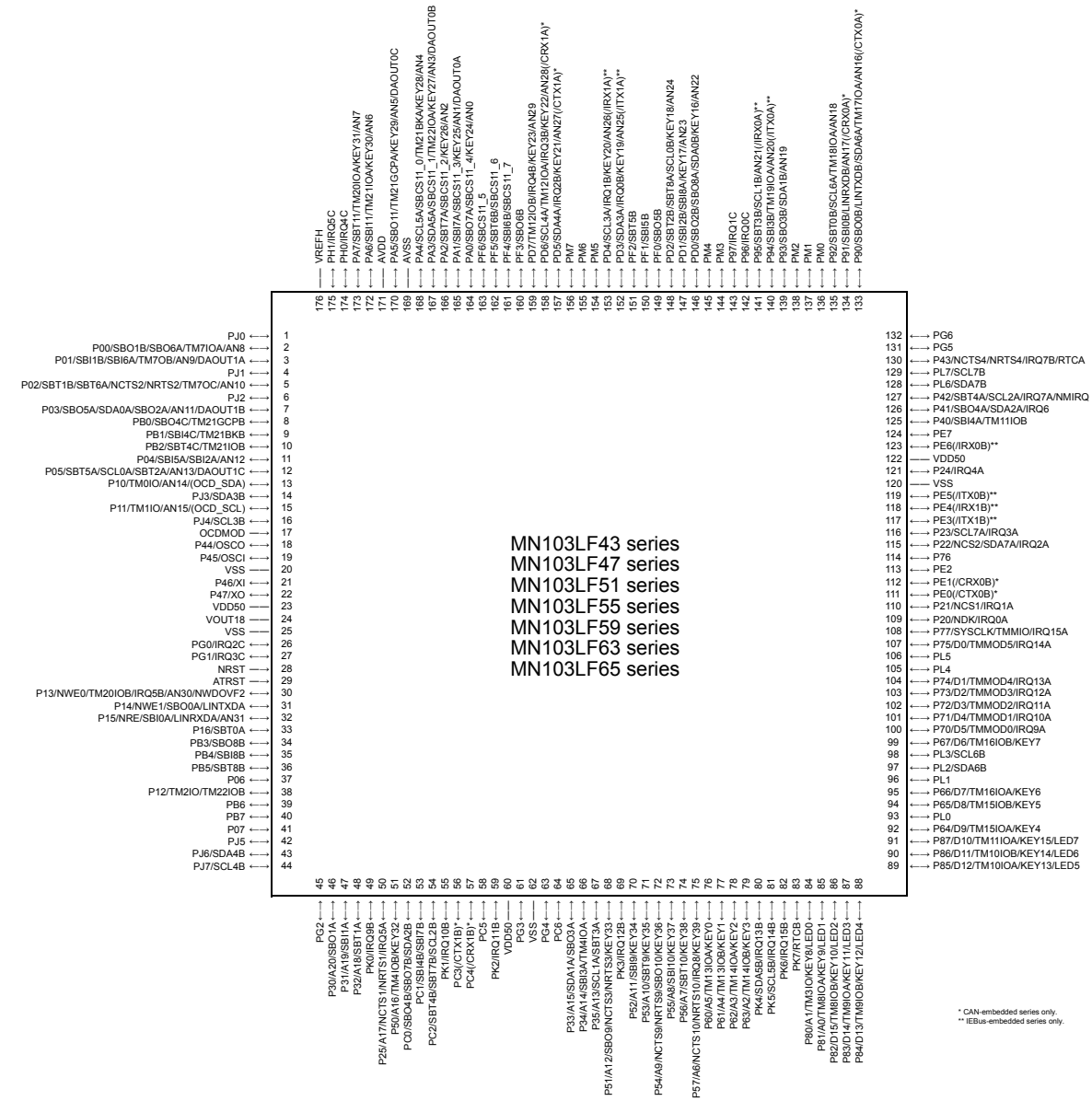

Figure:1.5.1 Pin Configuration of 176 pin Version

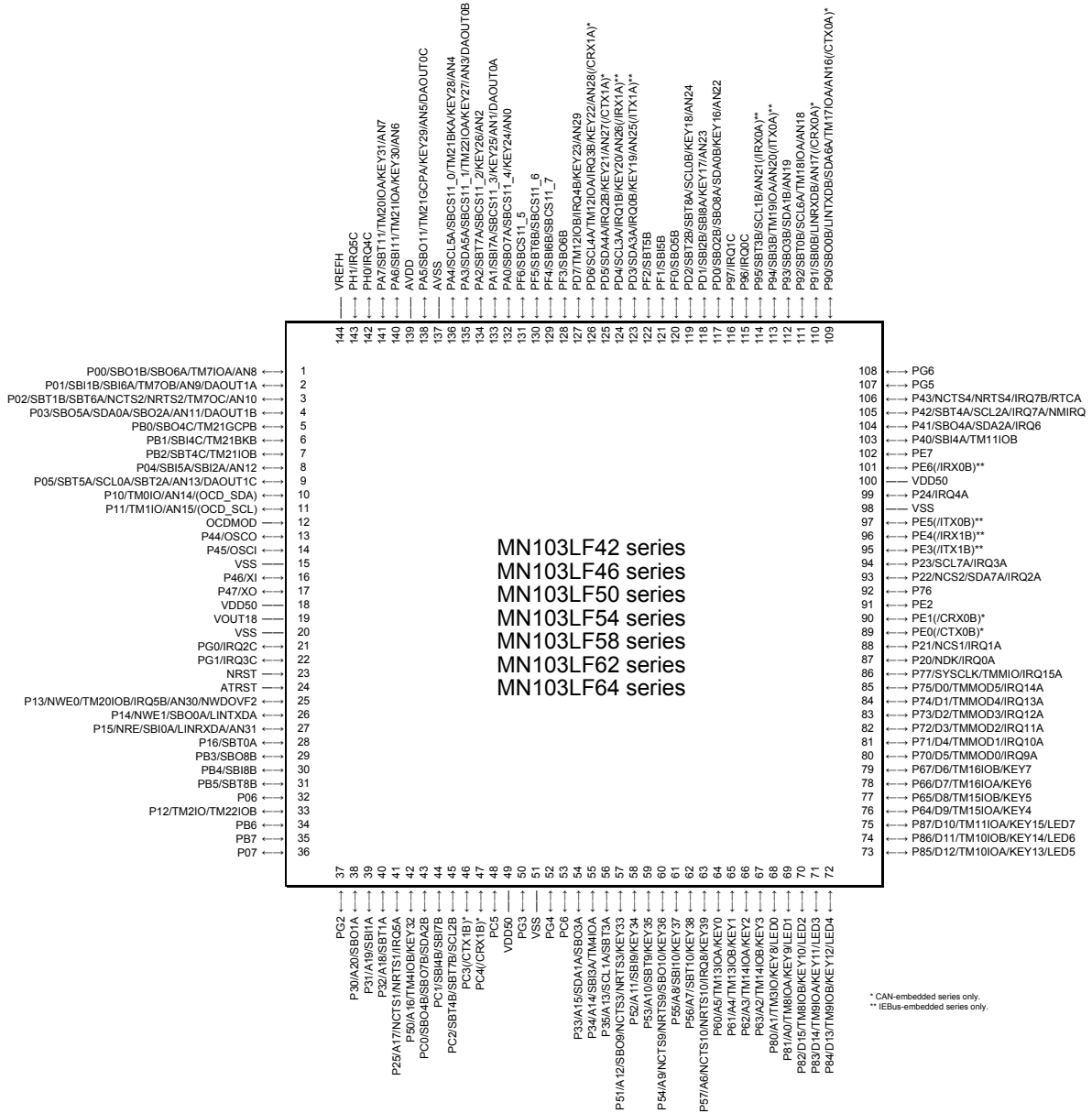
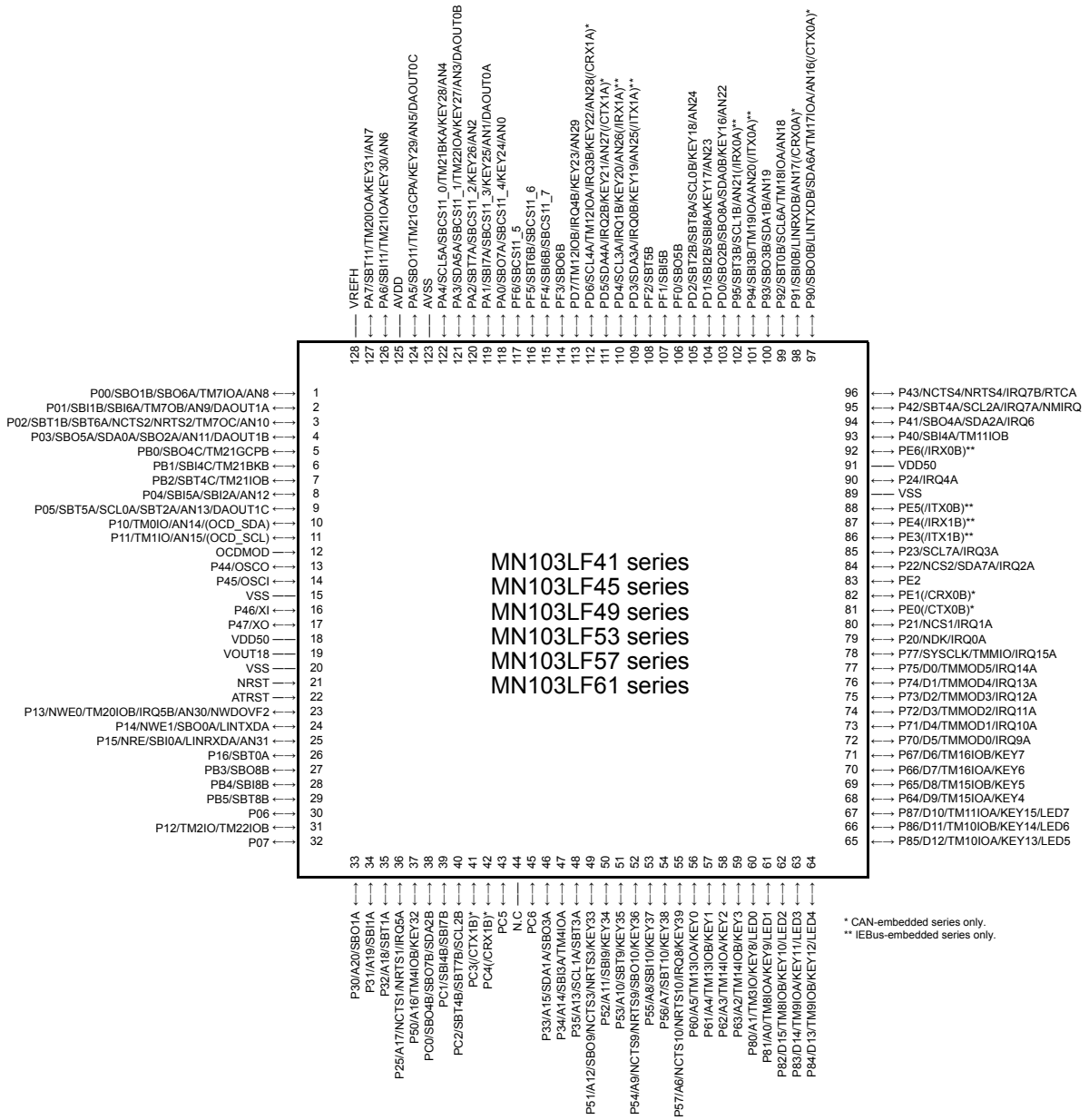
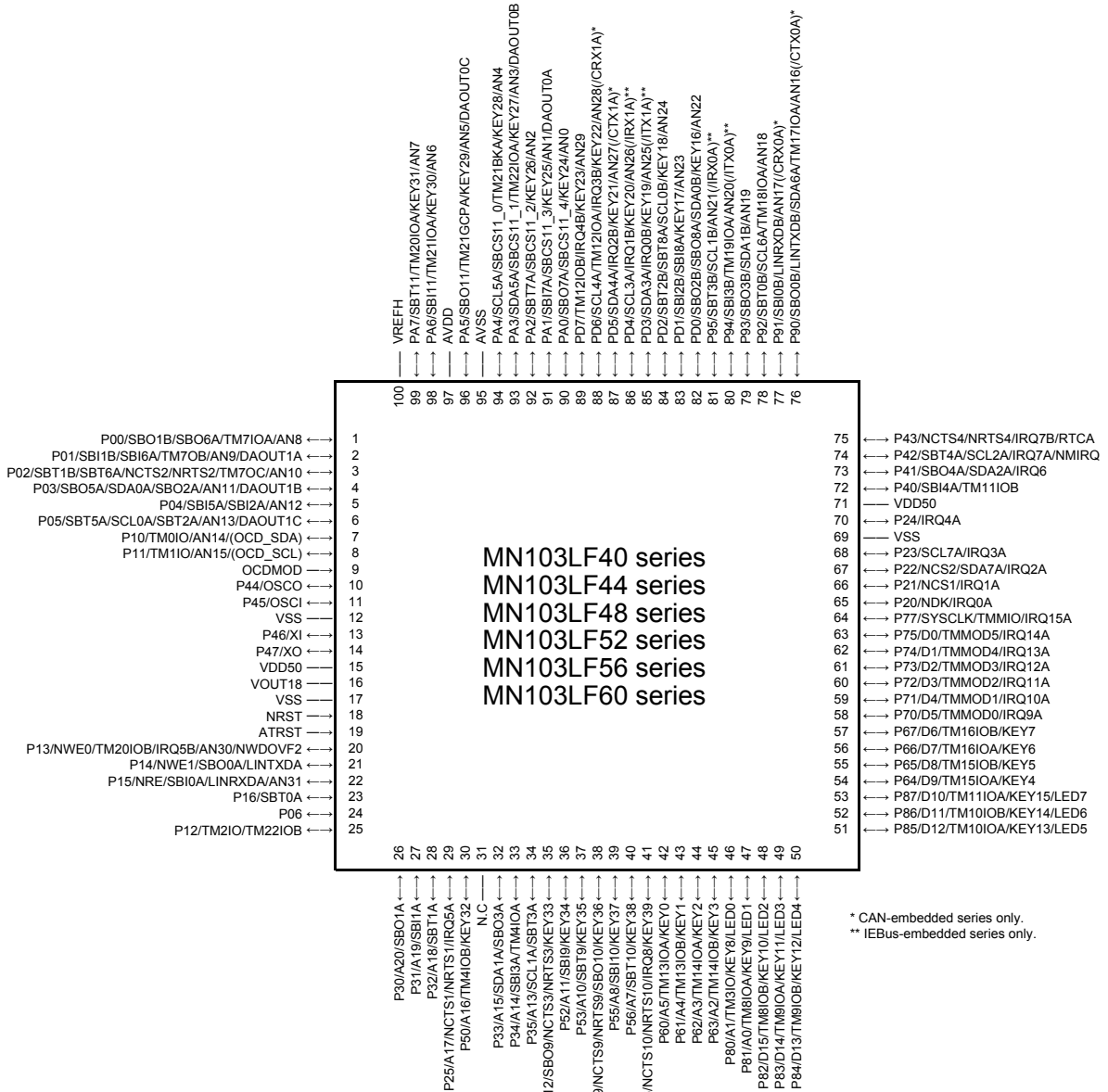

Figure:1.5.2 Pin Configuration of 144 pin Version



* CAN-embedded series only.
 ** I2C-embedded series only.

Figure:1.5.3 Pin Configuration of 128 pin Version



* CAN-embedded series only.
 ** IEBus-embedded series only.

Figure:1.5.4 Pin Configuration of 100 pin Version

Table:1.5.1 Pin Specification of 176 pin Version

Pin No.	Pin Name	Pin condition at Reset	Pin No.	Pin Name	Pin condition at Reset
1	PJ0	Hi-Z	89	P85 / D12 / TM10IOA / KEY13 / LED5	Hi-Z
2	P00 / SBO1B / SBO6A / TM7IOA / AN8	Hi-Z	90	P86 / D11 / TM10IOB / KEY14 / LED6	Hi-Z
3	P01 / SBI1B / SBI6A / TM7OB / AN9 / DAOUT1A	Hi-Z	91	P87 / D10 / TM11IOA / KEY15 / LED7	Hi-Z
4	PJ1	Hi-Z	92	P64 / D9 / TM15IOA / KEY4	Hi-Z
5	P02 / SBT1B / SBT6A / NCTS2 / NRTS2 / TM7OC / AN10	Hi-Z	93	PL0	Hi-Z
6	PJ2	Hi-Z	94	P65 / D8 / TM15IOB / KEY5	Hi-Z
7	P03 / SBO5A / SDA0A / SBO2A / AN11 / DAOUT1B	Hi-Z	95	P66 / D7 / TM16IOA / KEY6	Hi-Z
8	PB0 / SBO4C / TM21GCPB	Hi-Z	96	PL1	Hi-Z
9	PB1 / SBI4C / TM21BKB	Hi-Z	97	PL2 / SDA6B	Hi-Z
10	PB2 / SBT4C / TM21IOB	Hi-Z	98	PL3 / SCL6B	Hi-Z
11	P04 / SBI5A / SBI2A / AN12	Hi-Z	99	P67 / D6 / TM16IOB / KEY7	Hi-Z
12	P05 / SBT5A / SCL0A / SBT2A / AN13 / DAOUT1C	Hi-Z	100	P70 / D5 / TMMOD0 / IRQ9A	Hi-Z
13	P10 / TM0IO / AN14 / (OCD_SDA)	(*1)	101	P71 / D4 / TMMOD1 / IRQ10A	Hi-Z
14	PJ3 / SDA3B	Hi-Z	102	P72 / D3 / TMMOD2 / IRQ11A	Hi-Z
15	P11 / TM1IO / AN15 / (OCD_SCL)	(*1)	103	P73 / D2 / TMMOD3 / IRQ12A	Hi-Z
16	PJ4 / SCL3B	Hi-Z	104	P74 / D1 / TMMOD4 / IRQ13A	Hi-Z
17	OCDMOD	INPUT	105	PL4	Hi-Z
18	P44 / OSCO	Hi-Z	106	PL5	Hi-Z
19	P45 / OSCI	Hi-Z	107	P75 / D0 / TMMOD5 / IRQ14A	Hi-Z
20	VSS	-	108	P77 / SYSCLK / TMMIO / IRQ15A	Hi-Z
21	P46 / XI	Hi-Z	109	P20 / NDK / IRQ0A	Hi-Z
22	P47 / XO	Hi-Z	110	P21 / NCS1 / IRQ1A	Hi-Z
23	VDD50	-	111	PE0 (/ CTX0B) *2	Hi-Z
24	VOOUT18	-	112	PE1 (/ CRX0B) *2	Hi-Z
25	VSS	-	113	PE2	Hi-Z
26	PG0 / IRQ2C	Hi-Z	114	P76	Hi-Z
27	PG1 / IRQ3C	Hi-Z	115	P22 / NCS2 / SDA7A / IRQ2A	Hi-Z
28	NRST	INPUT	116	P23 / SCL7A / IRQ3A	Hi-Z
29	ATRST	INPUT	117	PE3 (/ ITX1B) *3	Hi-Z
30	P13 / NWE0 / TM20IOB / IRQ5B / AN30 / NWDOVF2	Hi-Z	118	PE4 (/ IRX1B) *3	Hi-Z
31	P14 / NWE1 / SBO0A / LINTXDA	Hi-Z	119	PE5 (/ ITX0B) *3	Hi-Z
32	P15 / NRE / SBI0A / LINRXDA / AN31	Hi-Z	120	VSS	-
33	P16 / SBT0A	Hi-Z	121	P24 / IRQ4A	Hi-Z
34	PB3 / SBO8B	Hi-Z	122	VDD50	-
35	PB4 / SBI8B	Hi-Z	123	PE6 (/ IRX0B) *3	Hi-Z
36	PB5 / SBT8B	Hi-Z	124	PE7	Hi-Z
37	P06	Hi-Z	125	P40 / SBI4A / TM11IOB	Hi-Z
38	P12 / TM2IO / TM22IOB	Hi-Z	126	P41 / SBO4A / SDA2A / IRQ6	Hi-Z
39	PB6	Hi-Z	127	P42 / SBT4A / SCL2A / IRQ7A / NMIRQ	Hi-Z
40	PB7	Hi-Z	128	PL6 / SDA7B	Hi-Z
41	P07	Hi-Z	129	PL7 / SCL7B	Hi-Z
42	PJ5	Hi-Z	130	P43 / NCTS4 / NRTS4 / IRQ7B / RTCA	Hi-Z
43	PJ6 / SDA4B	Hi-Z	131	PG5	Hi-Z
44	PJ7 / SCL4B	Hi-Z	132	PG6	Hi-Z
45	PG2	Hi-Z	133	P90 / SBO0B / LINTXDB / SDA6A / TM17IOA / AN16 (/ CTX0A) *2	Hi-Z
46	P30 / A20 / SBO1A	Hi-Z	134	P91 / SBI0B / LINRXDB / AN17 (/ CRX0A) *2	Hi-Z
47	P31 / A19 / SBI1A	Hi-Z	135	P92 / SBT0B / SCL6A / TM18IOA / AN18	Hi-Z
48	P32 / A18 / SBT1A	Hi-Z	136	PM0	Hi-Z
49	PK0 / IRQ9B	Hi-Z	137	PM1	Hi-Z
50	P25 / A17 / NCTS1 / NRTS1 / IRQ5A	Hi-Z	138	PM2	Hi-Z
51	P50 / A16 / TM4IOB / KEY32	Hi-Z	139	P93 / SBO3B / SDA1B / AN19	Hi-Z
52	PC0 / SBO4B / SBO7B / SDA2B	Hi-Z	140	P94 / SBI3B / TM19IOA / AN20 (/ ITX0A) *3	Hi-Z
53	PC1 / SBI4B / SBI7B	Hi-Z	141	P95 / SBT3B / SCL1B / AN21 (/ IRX0A) *3	Hi-Z
54	PC2 / SBT4B / SBT7B / SCL2B	Hi-Z	142	P96 / IRQ0C	Hi-Z
55	PK1 / IRQ10B	Hi-Z	143	P97 / IRQ1C	Hi-Z
56	PC3 (/ CTX1B) *2	Hi-Z	144	PM3	Hi-Z
57	PC4 (/ CRX1B) *2	Hi-Z	145	PM4	Hi-Z
58	PC5	Hi-Z	146	PD0 / SBO2B / SBO8A / SDA0B / KEY16 / AN22	Hi-Z
59	PK2 / IRQ11B	Hi-Z	147	PD1 / SBI2B / SBI8A / KEY17 / AN23	Hi-Z
60	VDD50	-	148	PD2 / SBT2B / SBT8A / SCL0B / KEY18 / AN24	Hi-Z
61	PG3	Hi-Z	149	PF0 / SBO5B	Hi-Z
62	VSS	-	150	PF1 / SBI5B	Hi-Z
63	PG4	Hi-Z	151	PF2 / SBT5B	Hi-Z
64	PC6	Hi-Z	152	PD3 / SDA3A / IRQ0B / KEY19 / AN25 (/ ITX1A) *3	Hi-Z



Pin No.	Pin Name	Pin condition at Reset	Pin No.	Pin Name	Pin condition at Reset
65	P33 / A15 / SDA1A / SBO3A	Hi-Z	153	PD4 / SCL3A / IRQ1B / KEY20 / AN26 (/ IRX1A) *3	Hi-Z
66	P34 / A14 / SBI3A / TM4IOA	Hi-Z	154	PM5	Hi-Z
67	P35 / A13 / SCL1A / SBT3A	Hi-Z	155	PM6	Hi-Z
68	P51 / A12 / SBO9 / NCTS3 / NRTS3 / KEY33	Hi-Z	156	PM7	Hi-Z
69	PK3 / IRQ12B	Hi-Z	157	PD5 / SDA4A / IRQ2B / KEY21 / AN27 (/ CTX1A) *2	Hi-Z
70	P52 / A11 / SBI9 / KEY34	Hi-Z	158	PD6 / SCL4A / TM12IOA / IRQ3B / KEY22 / AN28 (/ CRX1A) *2	Hi-Z
71	P53 / A10 / SBT9 / KEY35	Hi-Z	159	PD7 / TM12IOB / IRQ4B / KEY23 / AN29	Hi-Z
72	P54 / A9 / NCTS9 / NRTS9 / SBO10 / KEY36	Hi-Z	160	PF3 / SBO6B	Hi-Z
73	P55 / A8 / SBI10 / KEY37	Hi-Z	161	PF4 / SBI6B / SBCS11_7	Hi-Z
74	P56 / A7 / SBT10 / KEY38	Hi-Z	162	PF5 / SBT6B / SBCS11_6	Hi-Z
75	P57 / A6 / NCTS10 / NRTS10 / IRQ8 / KEY39	Hi-Z	163	PF6 / SBCS11_5	Hi-Z
76	P60 / A5 / TM13IOA / KEY0	Hi-Z	164	PA0 / SBO7A / SBCS11_4 / KEY24 / AN0	Hi-Z
77	P61 / A4 / TM13IOB / KEY1	Hi-Z	165	PA1 / SBI7A / SBCS11_3 / KEY25 / AN1 / DAOUT0A	Hi-Z
78	P62 / A3 / TM14IOA / KEY2	Hi-Z	166	PA2 / SBT7A / SBCS11_2 / KEY26 / AN2	Hi-Z
79	P63 / A2 / TM14IOB / KEY3	Hi-Z	167	PA3 / SDA5A / SBCS11_1 / TM22IOA / KEY27 / AN3 / DAOUT0B	Hi-Z
80	PK4 / SDA5B / IRQ13B	Hi-Z	168	PA4 / SCL5A / SBCS11_0 / TM21BKA / KEY28 / AN4	Hi-Z
81	PK5 / SCL5B / IRQ14B	Hi-Z	169	AVSS	-
82	PK6 / IRQ15B	Hi-Z	170	PA5 / SBO11 / TM21GCPA / KEY29 / AN5 / DAOUT0C	Hi-Z
83	PK7 / RTCB	Hi-Z	171	AVDD	-
84	P80 / A1 / TM3IO / KEY8 / LED0	Hi-Z	172	PA6 / SBI11 / TM21IOA / KEY30 / AN6	Hi-Z
85	P81 / A0 / TM8IOA / KEY9 / LED1	Hi-Z	173	PA7 / SBT11 / TM20IOA / KEY31 / AN7	Hi-Z
86	P82 / D15 / TM8IOB / KEY10 / LED2	Hi-Z	174	PH0 / IRQ4C	Hi-Z
87	P83 / D14 / TM9IOA / KEY11 / LED3	Hi-Z	175	PH1 / IRQ5C	Hi-Z
88	P84 / D13 / TM9IOB / KEY12 / LED4	Hi-Z	176	VREFH	-

*1 When OCDMOD is "L", state is "Hi-Z". When OCDMOD is "H", state is "INPUT".
*2 CAN-embedded series only..
*3 IEBus-embedded series only..

Table:1.5.2 Pin Specification of 144 pin Version

Pin No.	Pin Name	Pin condition at Reset	Pin No.	Pin Name	Pin condition at Reset
1	P00 / SBO1B / SBO6A / TM7IOA / AN8	Hi-Z	73	P85 / D12 / TM10IOA / KEY13 / LED5	Hi-Z
2	P01 / SBI1B / SBI6A / TM7OB / AN9 / DAOUT1A	Hi-Z	74	P86 / D11 / TM10IOB / KEY14 / LED6	Hi-Z
3	P02 / SBT1B / SBT6A / NCTS2 / NRTS2 / TM7OC / AN10	Hi-Z	75	P87 / D10 / TM11IOA / KEY15 / LED7	Hi-Z
4	P03 / SBO5A / SDA0A / SBO2A / AN11 / DAOUT1B	Hi-Z	76	P64 / D9 / TM15IOA / KEY4	Hi-Z
5	PB0 / SBO4C / TM21GCPB	Hi-Z	77	P65 / D8 / TM15IOB / KEY5	Hi-Z
6	PB1 / SBI4C / TM21BKB	Hi-Z	78	P66 / D7 / TM16IOA / KEY6	Hi-Z
7	PB2 / SBT4C / TM21IOB	Hi-Z	79	P67 / D6 / TM16IOB / KEY7	Hi-Z
8	P04 / SBI5A / SBI2A / AN12	Hi-Z	80	P70 / D5 / TMMOD0 / IRQ9A	Hi-Z
9	P05 / SBT5A / SCL0A / SBT2A / AN13 / DAOUT1C	Hi-Z	81	P71 / D4 / TMMOD1 / IRQ10A	Hi-Z
10	P10 / TM0IO / AN14 / (OCD_SDA)	(*1)	82	P72 / D3 / TMMOD2 / IRQ11A	Hi-Z
11	P11 / TM1IO / AN15 / (OCD_SCL)	(*1)	83	P73 / D2 / TMMOD3 / IRQ12A	Hi-Z
12	OCDMOD	INPUT	84	P74 / D1 / TMMOD4 / IRQ13A	Hi-Z
13	P44 / OSCO	Hi-Z	85	P75 / D0 / TMMOD5 / IRQ14A	Hi-Z
14	P45 / OSCI	Hi-Z	86	P77 / SYSCLK / TMMIO / IRQ15A	Hi-Z
15	VSS	-	87	P20 / NDK / IRQ0A	Hi-Z
16	P46 / XI	Hi-Z	88	P21 / NCS1 / IRQ1A	Hi-Z
17	P47 / XO	Hi-Z	89	PE0 (/ CTX0B) *2	Hi-Z
18	VDD50	-	90	PE1 (/ CRX0B) *2	Hi-Z
19	VOOUT18	-	91	PE2	Hi-Z
20	VSS	-	92	P76	Hi-Z
21	PG0 / IRQ2C	Hi-Z	93	P22 / NCS2 / SDA7A / IRQ2A	Hi-Z
22	PG1 / IRQ3C	Hi-Z	94	P23 / SCL7A / IRQ3A	Hi-Z
23	NRST	INPUT	95	PE3 (/ ITX1B) *3	Hi-Z
24	ATRST	INPUT	96	PE4 (/ IRX1B) *3	Hi-Z
25	P13 / NWE0 / TM20IOB / IRQ5B / AN30 / NWDOVF2	Hi-Z	97	PE5 (/ ITX0B) *3	Hi-Z
26	P14 / NWE1 / SBO0A / LINTXDA	Hi-Z	98	VSS	-
27	P15 / NRE / SBI0A / LINRXDA / AN31	Hi-Z	99	P24 / IRQ4A	Hi-Z
28	P16 / SBT0A	Hi-Z	100	VDD50	-
29	PB3 / SBO8B	Hi-Z	101	PE6 (/ IRX0B) *3	Hi-Z
30	PB4 / SBI8B	Hi-Z	102	PE7	Hi-Z
31	PB5 / SBT8B	Hi-Z	103	P40 / SBI4A / TM11IOB	Hi-Z
32	P06	Hi-Z	104	P41 / SBO4A / SDA2A / IRQ6	Hi-Z
33	P12 / TM2IO / TM22IOB	Hi-Z	105	P42 / SBT4A / SCL2A / IRQ7A / NMIRQ	Hi-Z
34	PB6	Hi-Z	106	P43 / NCTS4 / NRTS4 / IRQ7B / RTCA	Hi-Z
35	PB7	Hi-Z	107	PG5	Hi-Z
36	P07	Hi-Z	108	PG6	Hi-Z
37	PG2	Hi-Z	109	P90 / SBO0B / LINTXDB / SDA6A / TM17IOA / AN16 (/ CTX0A) *2	Hi-Z
38	P30 / A20 / SBO1A	Hi-Z	110	P91 / SBI0B / LINRXDB / AN17 (/ CRX0A) *2	Hi-Z
39	P31 / A19 / SBI1A	Hi-Z	111	P92 / SBT0B / SCL6A / TM18IOA / AN18	Hi-Z
40	P32 / A18 / SBT1A	Hi-Z	112	P93 / SBO3B / SDA1B / AN19	Hi-Z
41	P25 / A17 / NCTS1 / NRTS1 / IRQ5A	Hi-Z	113	P94 / SBI3B / TM19IOA / AN20 (/ ITX0A) *3	Hi-Z
42	P50 / A16 / TM4IOB / KEY32	Hi-Z	114	P95 / SBT3B / SCL1B / AN21 (/ IRX0A) *3	Hi-Z
43	PC0 / SBO4B / SBO7B / SDA2B	Hi-Z	115	P96 / IRQ0C	Hi-Z
44	PC1 / SBI4B / SBI7B	Hi-Z	116	P97 / IRQ1C	Hi-Z
45	PC2 / SBT4B / SBT7B / SCL2B	Hi-Z	117	PD0 / SBO2B / SBO8A / SDA0B / KEY16 / AN22	Hi-Z
46	PC3 (/ CTX1B) *2	Hi-Z	118	PD1 / SBI2B / SBI8A / KEY17 / AN23	Hi-Z
47	PC4 (/ CRX1B) *2	Hi-Z	119	PD2 / SBT2B / SBT8A / SCL0B / KEY18 / AN24	Hi-Z
48	PC5	Hi-Z	120	PF0 / SBO5B	Hi-Z
49	VDD50	-	121	PF1 / SBI5B	Hi-Z
50	PG3	Hi-Z	122	PF2 / SBT5B	Hi-Z
51	VSS	-	123	PD3 / SDA3A / IRQ0B / KEY19 / AN25 (/ ITX1A) *3	Hi-Z
52	PG4	Hi-Z	124	PD4 / SCL3A / IRQ1B / KEY20 / AN26 (/ IRX1A) *3	Hi-Z
53	PC6	Hi-Z	125	PD5 / SDA4A / IRQ2B / KEY21 / AN27 (/ CTX1A) *2	Hi-Z
54	P33 / A15 / SDA1A / SBO3A	Hi-Z	126	PD6 / SCL4A / TM12IOA / IRQ3B / KEY22 / AN28 (/ CRX1A) *2	Hi-Z
55	P34 / A14 / SBI3A / TM4IOA	Hi-Z	127	PD7 / TM12IOB / IRQ4B / KEY23 / AN29	Hi-Z
56	P35 / A13 / SCL1A / SBT3A	Hi-Z	128	PF3 / SBO6B	Hi-Z
57	P51 / A12 / SBO9 / NCTS3 / NRTS3 / KEY33	Hi-Z	129	PF4 / SBI6B / SBSCS11_7	Hi-Z
58	P52 / A11 / SBI9 / KEY34	Hi-Z	130	PF5 / SBT6B / SBSCS11_6	Hi-Z
59	P53 / A10 / SBT9 / KEY35	Hi-Z	131	PF6 / SBSCS11_5	Hi-Z
60	P54 / A9 / NCTS9 / NRTS9 / SBO10 / KEY36	Hi-Z	132	PA0 / SBO7A / SBSCS11_4 / KEY24 / AN0	Hi-Z
61	P55 / A8 / SBI10 / KEY37	Hi-Z	133	PA1 / SBI7A / SBSCS11_3 / KEY25 / AN1 / DAOUT0A	Hi-Z



Pin No.	Pin Name	Pin condition at Reset	Pin No.	Pin Name	Pin condition at Reset
62	P56 / A7 / SBT10 / KEY38	Hi-Z	134	PA2 / SBT7A / SBCS11_2 / KEY26 / AN2	Hi-Z
63	P57 / A6 / NCTS10 / NRSTS10 / IRQ8 / KEY39	Hi-Z	135	PA3 / SDA5A / SBCS11_1 / TM22IOA / KEY27 / AN3 / DAOUT0B	Hi-Z
64	P60 / A5 / TM13IOA / KEY0	Hi-Z	136	PA4 / SCL5A / SBCS11_0 / TM21BKA / KEY28 / AN4	Hi-Z
65	P61 / A4 / TM13IOB / KEY1	Hi-Z	137	AVSS	-
66	P62 / A3 / TM14IOA / KEY2	Hi-Z	138	PA5 / SBO11 / TM21GCPA / KEY29 / AN5 / DAOUT0C	Hi-Z
67	P63 / A2 / TM14IOB / KEY3	Hi-Z	139	AVDD	-
68	P80 / A1 / TM3IO / KEY8 / LED0	Hi-Z	140	PA6 / SBI11 / TM21IOA / KEY30 / AN6	Hi-Z
69	P81 / A0 / TM8IOA / KEY9 / LED1	Hi-Z	141	PA7 / SBT11 / TM20IOA / KEY31 / AN7	Hi-Z
70	P82 / D15 / TM8IOB / KEY10 / LED2	Hi-Z	142	PH0 / IRQ4C	Hi-Z
71	P83 / D14 / TM9IOA / KEY11 / LED3	Hi-Z	143	PH1 / IRQ5C	Hi-Z
72	P84 / D13 / TM9IOB / KEY12 / LED4	Hi-Z	144	VREFH	-

*1 When OCDMOD is "L", state is "Hi-Z". When OCDMOD is "H", state is "INPUT".

*2 CAN-embedded series only..

*3 IEBus-embedded series only..

Table:1.5.3 Pin Specification of 128 pin Version

Pin No.	Pin Name	Pin condition at Reset	Pin No.	Pin Name	Pin condition at Reset
1	P00 / SBO1B / SBO6A / TM7IOA / AN8	Hi-Z	65	P85 / D12 / TM10IOA / KEY13 / LED5	Hi-Z
2	P01 / SBI1B / SBI6A / TM7OB / AN9 / DAOUT1A	Hi-Z	66	P86 / D11 / TM10IOB / KEY14 / LED6	Hi-Z
3	P02 / SBT1B / SBT6A / NCTS2 / NRTS2 / TM7OC / AN10	Hi-Z	67	P87 / D10 / TM11IOA / KEY15 / LED7	Hi-Z
4	P03 / SBO5A / SDA0A / SBO2A / AN11 / DAOUT1B	Hi-Z	68	P64 / D9 / TM15IOA / KEY4	Hi-Z
5	PB0 / SBO4C / TM21GCPB	Hi-Z	69	P65 / D8 / TM15IOB / KEY5	Hi-Z
6	PB1 / SBI4C / TM21BKB	Hi-Z	70	P66 / D7 / TM16IOA / KEY6	Hi-Z
7	PB2 / SBT4C / TM21IOB	Hi-Z	71	P67 / D6 / TM16IOB / KEY7	Hi-Z
8	P04 / SBI5A / SBI2A / AN12	Hi-Z	72	P70 / D5 / TMMOD0 / IRQ9A	Hi-Z
9	P05 / SBT5A / SCL0A / SBT2A / AN13 / DAOUT1C	Hi-Z	73	P71 / D4 / TMMOD1 / IRQ10A	Hi-Z
10	P10 / TM0IO / AN14 / (OCD_SDA)	(*1)	74	P72 / D3 / TMMOD2 / IRQ11A	Hi-Z
11	P11 / TM1IO / AN15 / (OCD_SCL)	(*1)	75	P73 / D2 / TMMOD3 / IRQ12A	Hi-Z
12	OCDMOD	INPUT	76	P74 / D1 / TMMOD4 / IRQ13A	Hi-Z
13	P44 / OSCO	Hi-Z	77	P75 / D0 / TMMOD5 / IRQ14A	Hi-Z
14	P45 / OSCI	Hi-Z	78	P77 / SYSCLK / TMMIO / IRQ15A	Hi-Z
15	VSS	-	79	P20 / NDK / IRQ0A	Hi-Z
16	P46 / XI	Hi-Z	80	P21 / NCS1 / IRQ1A	Hi-Z
17	P47 / XO	Hi-Z	81	PE0 (/ CTX0B) *2	Hi-Z
18	VDD50	-	82	PE1 (/ CRX0B) *2	Hi-Z
19	VOOUT18	-	83	PE2	Hi-Z
20	VSS	-	84	P22 / NCS2 / SDA7A / IRQ2A	Hi-Z
21	NRST	INPUT	85	P23 / SCL7A / IRQ3A	Hi-Z
22	ATRST	INPUT	86	PE3 (/ ITX1B) *3	Hi-Z
23	P13 / NWE0 / TM20IOB / IRQ5B / AN30 / NWDVDF2	Hi-Z	87	PE4 (/ IRX1B) *3	Hi-Z
24	P14 / NWE1 / SBO0A / LINTXDA	Hi-Z	88	PE5 (/ ITX0B) *3	Hi-Z
25	P15 / NRE / SBI0A / LINRXDA / AN31	Hi-Z	89	VSS	-
26	P16 / SBT0A	Hi-Z	90	P24 / IRQ4A	Hi-Z
27	PB3 / SBO8B	Hi-Z	91	VDD50	-
28	PB4 / SBI8B	Hi-Z	92	PE6 (/ IRX0B) *3	Hi-Z
29	PB5 / SBT8B	Hi-Z	93	P40 / SBI4A / TM11IOB	Hi-Z
30	P06	Hi-Z	94	P41 / SBO4A / SDA2A / IRQ6	Hi-Z
31	P12 / TM2IO / TM22IOB	Hi-Z	95	P42 / SBT4A / SCL2A / IRQ7A / NMIRQ	Hi-Z
32	P07	Hi-Z	96	P43 / NCTS4 / NRTS4 / IRQ7B / RTCA	Hi-Z
33	P30 / A20 / SBO1A	Hi-Z	97	P90 / SBO0B / LINTXDB / SDA6A / TM17IOA / AN16 (/ CTX0A) *2	Hi-Z
34	P31 / A19 / SBI1A	Hi-Z	98	P91 / SBI0B / LINRXDB / AN17 (/ CRX0A) *2	Hi-Z
35	P32 / A18 / SBT1A	Hi-Z	99	P92 / SBT0B / SCL6A / TM18IOA / AN18	Hi-Z
36	P25 / A17 / NCTS1 / NRTS1 / IRQ5A	Hi-Z	100	P93 / SBO3B / SDA1B / AN19	Hi-Z
37	P50 / A16 / TM4IOB / KEY32	Hi-Z	101	P94 / SBI3B / TM19IOA / AN20 (/ ITX0A) *3	Hi-Z
38	PC0 / SBO4B / SBO7B / SDA2B	Hi-Z	102	P95 / SBT3B / SCL1B / AN21 (/ IRX0A) *3	Hi-Z
39	PC1 / SBI4B / SBI7B	Hi-Z	103	PD0 / SBO2B / SBO8A / SDA0B / KEY16 / AN22	Hi-Z
40	PC2 / SBT4B / SBT7B / SCL2B	Hi-Z	104	PD1 / SBI2B / SBI8A / KEY17 / AN23	Hi-Z
41	PC3 (/ CTX1B) *2	Hi-Z	105	PD2 / SBT2B / SBT8A / SCL0B / KEY18 / AN24	Hi-Z
42	PC4 (/ CRX1B) *2	Hi-Z	106	PF0 / SBO5B	Hi-Z
43	PC5	Hi-Z	107	PF1 / SBI5B	Hi-Z
44	N.C	-	108	PF2 / SBT5B	Hi-Z
45	PC6	Hi-Z	109	PD3 / SDA3A / IRQ0B / KEY19 / AN25 (/ ITX1A) *3	Hi-Z
46	P33 / A15 / SDA1A / SBO3A	Hi-Z	110	PD4 / SCL3A / IRQ1B / KEY20 / AN26 (/ IRX1A) *3	Hi-Z
47	P34 / A14 / SBI3A / TM4IOA	Hi-Z	111	PD5 / SDA4A / IRQ2B / KEY21 / AN27 (/ CTX1A) *2	Hi-Z
48	P35 / A13 / SCL1A / SBT3A	Hi-Z	112	PD6 / SCL4A / TM12IOA / IRQ3B / KEY22 / AN28 (/ CRX1A) *2	Hi-Z
49	P51 / A12 / SBO9 / NCTS3 / NRTS3 / KEY33	Hi-Z	113	PD7 / TM12IOB / IRQ4B / KEY23 / AN29	Hi-Z
50	P52 / A11 / SBI9 / KEY34	Hi-Z	114	PF3 / SBO6B	Hi-Z
51	P53 / A10 / SBT9 / KEY35	Hi-Z	115	PF4 / SBI6B / SBSCS11_7	Hi-Z
52	P54 / A9 / NCTS9 / NRTS9 / SBO10 / KEY36	Hi-Z	116	PF5 / SBT6B / SBSCS11_6	Hi-Z
53	P55 / A8 / SBI10 / KEY37	Hi-Z	117	PF6 / SBSCS11_5	Hi-Z
54	P56 / A7 / SBT10 / KEY38	Hi-Z	118	PA0 / SBO7A / SBSCS11_4 / KEY24 / AN0	Hi-Z
55	P57 / A6 / NCTS10 / NRTS10 / IRQ8 / KEY39	Hi-Z	119	PA1 / SBI7A / SBSCS11_3 / KEY25 / AN1 / DAOUT0A	Hi-Z
56	P60 / A5 / TM13IOA / KEY0	Hi-Z	120	PA2 / SBT7A / SBSCS11_2 / KEY26 / AN2	Hi-Z
57	P61 / A4 / TM13IOB / KEY1	Hi-Z	121	PA3 / SDA5A / SBSCS11_1 / TM22IOA / KEY27 / AN3 / DAOUT0B	Hi-Z
58	P62 / A3 / TM14IOA / KEY2	Hi-Z	122	PA4 / SCL5A / SBSCS11_0 / TM21BKA / KEY28 / AN4	Hi-Z



Pin No.	Pin Name	Pin condition at Reset
59	P63 / A2 / TM14IOB / KEY3	Hi-Z
60	P80 / A1 / TM3IO / KEY8 / LED0	Hi-Z
61	P81 / A0 / TM8IOA / KEY9 / LED1	Hi-Z
62	P82 / D15 / TM8IOB / KEY10 / LED2	Hi-Z
63	P83 / D14 / TM9IOA / KEY11 / LED3	Hi-Z
64	P84 / D13 / TM9IOB / KEY12 / LED4	Hi-Z

Pin No.	Pin Name	Pin condition at Reset
123	AVSS	-
124	PA5 / SBO11 / TM21GCPA / KEY29 / AN5 / DAOUT0C	Hi-Z
125	AVDD	-
126	PA6 / SBI11 / TM21IOA / KEY30 / AN6	Hi-Z
127	PA7 / SBT11 / TM20IOA / KEY31 / AN7	Hi-Z
128	VREFH	-

*1 When OCDMOD is "L", state is "Hi-Z". When OCDMOD is "H", state is "INPUT".

*2 CAN-embedded series only..

*3 IEBus-embedded series only..

Table:1.5.4 Pin Specification of 100 pin Version

Pin No.	Pin Name	Pin condition at Reset	Pin No.	Pin Name	Pin condition at Reset
1	P00 / SBO1B / SBO6A / TM7IOA / AN8	Hi-Z	51	P85 / D12 / TM10IOA / KEY13 / LED5	Hi-Z
2	P01 / SBI1B / SBI6A / TM7OB / AN9 / DAOUT1A	Hi-Z	52	P86 / D11 / TM10IOB / KEY14 / LED6	Hi-Z
3	P02 / SBT1B / SBT6A / NCTS2 / NRTS2 / TM7OC / AN10	Hi-Z	53	P87 / D10 / TM11IOA / KEY15 / LED7	Hi-Z
4	P03 / SBO5A / SDA0A / SBO2A / AN11 / DAOUT1B	Hi-Z	54	P64 / D9 / TM15IOA / KEY4	Hi-Z
5	P04 / SBI5A / SBI2A / AN12	Hi-Z	55	P65 / D8 / TM15IOB / KEY5	Hi-Z
6	P05 / SBT5A / SCL0A / SBT2A / AN13 / DAOUT1C	Hi-Z	56	P66 / D7 / TM16IOA / KEY6	Hi-Z
7	P10 / TM0IO / AN14 / (OCD_SDA)	(*1)	57	P67 / D6 / TM16IOB / KEY7	Hi-Z
8	P11 / TM1IO / AN15 / (OCD_SCL)	(*1)	58	P70 / D5 / TMMOD0 / IRQ9A	Hi-Z
9	OCDMOD	INPUT	59	P71 / D4 / TMMOD1 / IRQ10A	Hi-Z
10	P44 / OSCO	Hi-Z	60	P72 / D3 / TMMOD2 / IRQ11A	Hi-Z
11	P45 / OSCI	Hi-Z	61	P73 / D2 / TMMOD3 / IRQ12A	Hi-Z
12	VSS	-	62	P74 / D1 / TMMOD4 / IRQ13A	Hi-Z
13	P46 / XI	Hi-Z	63	P75 / D0 / TMMOD5 / IRQ14A	Hi-Z
14	P47 / XO	Hi-Z	64	P77 / SYSCLK / TMMIO / IRQ15A	Hi-Z
15	VDD50	-	65	P20 / NDK / IRQ0A	Hi-Z
16	VOOUT18	-	66	P21 / NCS1 / IRQ1A	Hi-Z
17	VSS	-	67	P22 / NCS2 / SDA7A / IRQ2A	Hi-Z
18	NRST	INPUT	68	P23 / SCL7A / IRQ3A	Hi-Z
19	ATRST	INPUT	69	VSS	-
20	P13 / NWE0 / TM20IOB / IRQ5B / AN30 / NWDOVF2	Hi-Z	70	P24 / IRQ4A	Hi-Z
21	P14 / NWE1 / SBO0A / LINTXDA	Hi-Z	71	VDD50	-
22	P15 / NRE / SBI0A / LINRXDA / AN31	Hi-Z	72	P40 / SBI4A / TM11IOB	Hi-Z
23	P16 / SBT0A	Hi-Z	73	P41 / SBO4A / SDA2A / IRQ6	Hi-Z
24	P06	Hi-Z	74	P42 / SBT4A / SCL2A / IRQ7A / NMIRQ	Hi-Z
25	P12 / TM2IO / TM22IOB	Hi-Z	75	P43 / NCTS4 / NRTS4 / IRQ7B / RTCA	Hi-Z
26	P30 / A20 / SBO1A	Hi-Z	76	P90 / SBO0B / LINTXDB / SDA6A / TM17IOA / AN16 (/ CTX0A) *2	Hi-Z
27	P31 / A19 / SBI1A	Hi-Z	77	P91 / SBI0B / LINRXDB / AN17 (/ CRX0A) *2	Hi-Z
28	P32 / A18 / SBT1A	Hi-Z	78	P92 / SBT0B / SCL6A / TM18IOA / AN18	Hi-Z
29	P25 / A17 / NCTS1 / NRTS1 / IRQ5A	Hi-Z	79	P93 / SBO3B / SDA1B / AN19	Hi-Z
30	P50 / A16 / TM4IOB / KEY32	Hi-Z	80	P94 / SBI3B / TM19IOA / AN20 (/ ITX0A) *3	Hi-Z
31	N.C	-	81	P95 / SBT3B / SCL1B / AN21 (/ IRX0A) *3	Hi-Z
32	P33 / A15 / SDA1A / SBO3A	Hi-Z	82	PD0 / SBO2B / SBO8A / SDA0B / KEY16 / AN22	Hi-Z
33	P34 / A14 / SBI3A / TM4IOA	Hi-Z	83	PD1 / SBI2B / SBI8A / KEY17 / AN23	Hi-Z
34	P35 / A13 / SCL1A / SBT3A	Hi-Z	84	PD2 / SBT2B / SBT8A / SCL0B / KEY18 / AN24	Hi-Z
35	P51 / A12 / SBO9 / NCTS3 / NRTS3 / KEY33	Hi-Z	85	PD3 / SDA3A / IRQ0B / KEY19 / AN25 (/ ITX1A) *3	Hi-Z
36	P52 / A11 / SBI9 / KEY34	Hi-Z	86	PD4 / SCL3A / IRQ1B / KEY20 / AN26 (/ IRX1A) *3	Hi-Z
37	P53 / A10 / SBT9 / KEY35	Hi-Z	87	PD5 / SDA4A / IRQ2B / KEY21 / AN27 (/ CTX1A) *2	Hi-Z
38	P54 / A9 / NCTS9 / NRTS9 / SBO10 / KEY36	Hi-Z	88	PD6 / SCL4A / TM12IOA / IRQ3B / KEY22 / AN28 (/ CRX1A) *2	Hi-Z
39	P55 / A8 / SBI10 / KEY37	Hi-Z	89	PD7 / TM12IOB / IRQ4B / KEY23 / AN29	Hi-Z
40	P56 / A7 / SBT10 / KEY38	Hi-Z	90	PA0 / SBO7A / SBSC11_4 / KEY24 / AN0	Hi-Z
41	P57 / A6 / NCTS10 / NRTS10 / IRQ8 / KEY39	Hi-Z	91	PA1 / SBI7A / SBSC11_3 / KEY25 / AN1 / DAOUT0A	Hi-Z
42	P60 / A5 / TM13IOA / KEY0	Hi-Z	92	PA2 / SBT7A / SBSC11_2 / KEY26 / AN2	Hi-Z
43	P61 / A4 / TM13IOB / KEY1	Hi-Z	93	PA3 / SDA5A / SBSC11_1 / TM22IOA / KEY27 / AN3 / DAOUT0B	Hi-Z
44	P62 / A3 / TM14IOA / KEY2	Hi-Z	94	PA4 / SCL5A / SBSC11_0 / TM21BKA / KEY28 / AN4	Hi-Z
45	P63 / A2 / TM14IOB / KEY3	Hi-Z	95	AVSS	-



Pin No.	Pin Name	Pin condition at Reset
46	P80 / A1 / TM3IO / KEY8 / LED0	Hi-Z
47	P81 / A0 / TM8IOA / KEY9 / LED1	Hi-Z
48	P82 / D15 / TM8IOB / KEY10 / LED2	Hi-Z
49	P83 / D14 / TM9IOA / KEY11 / LED3	Hi-Z
50	P84 / D13 / TM9IOB / KEY12 / LED4	Hi-Z

Pin No.	Pin Name	Pin condition at Reset
96	PA5 / SBO11 / TM21GCPA / KEY29 / AN5 / DAOUT0C	Hi-Z
97	AVDD	-
98	PA6 / SBI11 / TM21IOA / KEY30 / AN6	Hi-Z
99	PA7 / SBT11 / TM20IOA / KEY31 / AN7	Hi-Z
100	VREFH	-

*1 When OCDMOD is "L", state is "Hi-Z". When OCDMOD is "H", state is "INPUT".

*2 CAN-embedded series only..

*3 IEBus-embedded series only..

1.5.2 Pin Functions

Table:1.5.5 shows pin functions of 176 pin version.

Table:1.5.5 Pin Functions of 176 pin Version

	Pin	Other Function				Description	
Power supply / Ground *1	VDD50					On-chip regulator power supply Power supply for I/O	
	AVDD					Power supply for analog operation.	
	VOOUT18					Power supply for internal circuit.	
	VREFH					Reference power supply pin for the A/D converter.	
	VSS					Ground	
	AVSS					Ground pin for analog.	
Function control *1	OCDMOD					On-chip debug function (OCD) control pin	
	ATRST					Auto reset setting pin.	
Reset	NRST					Reset signal input pin (Active low)	
Clock	OSCI	P45				High-speed oscillation input pin (clkosc = 4 to 20 MHz)	
	OSCO	P44				High-speed oscillation output pin	
	XI	P46				Low-speed oscillation input pin (clkx = 32.768 kHz)	
	XO	P47				Low-speed oscillation output pin	
	SYSClk	P77	TMMIO	IRQ15A			System clock signal output pin
Bus	A20	P30	SBO1A			Address output pins at Memory expansion mode	
	A19	P31	SBI1A				
	A18	P32	SBT1A				
	A17	P25	NCTS1/ NRTS1	IRQ5A			
	A16	P50	TM4IOB	KEY32			
	A15	P33	SDA1A	SBO3A			
	A14	P34	SBI3A	TM4IOA			
	A13	P35	SCL1A	SBT3A			
	A12	P51	SBO9	NCTS3/ NRTS3	KEY33		
	A11	P52	SBI9	KEY34			
	A10	P53	SBT9	KEY35			
	A9	P54	NCTS9/ NRTS9	SBO10	KEY36		
	A8	P55	SBI10	KEY37			
	A7	P56	SBT10	KEY38			
	A6	P57	NCTS10/ NRTS10	IRQ8	KEY39		
	A5	P60	TM13IOA	KEY0			
	A4	P61	TM13IOB	KEY1			
	A3	P62	TM14IOA	KEY2			
	A2	P63	TM14IOB	KEY3			
	A1	P80	TM3IO	KEY8	LED0		
	A0	P81	TM8IOA	KEY9	LED1		
	D15	P82	TM8IOB	KEY10	LED2		
	D14	P83	TM9IOA	KEY11	LED3		
	D13	P84	TM9IOB	KEY12	LED4		
	D12	P85	TM10IOA	KEY13	LED5		
	D11	P86	TM10IOB	KEY14	LED6		
	D10	P87	TM11IOA	KEY15	LED7		
	D9	P64	TM15IOA	KEY4			
	D8	P65	TM15IOB	KEY5			
	D7	P66	TM16IOA	KEY6			
D6	P67	TM16IOB	KEY7				
						Data I/O pins at Memory expansion mode	



	Pin	Other Function					Description	
Bus	D5	P70	TMMOD0	IRQ9A			Data I/O pins at Memory expansion mode	
	D4	P71	TMMOD1	IRQ10A				
	D3	P72	TMMOD2	IRQ11A				
	D2	P73	TMMOD3	IRQ12A				
	D1	P74	TMMOD4	IRQ13A				
	D0	P75	TMMOD5	IRQ14A				
		NCS2	P22	SDA7A	IRQ2A			Chip select signal output pins (Active low)
		NCS1	P21	IRQ1A				
		NRE	P15	SBI0A	AN31	LINRXDA		Read enable signal output pin (Active low)
		NWE1	P14	SBO0A	LINTXDA			Write enable signal output pins (Active low)
		NWE0	P13	TM20IOB	IRQ5B	AN30	NWDOVF2	
	NDK	P20	IRQ0A				Acknowledge signal input pin (Active low)	
Watchdog timer 2	NWDOVF2	P13	NWE0	TM20IOB	IRQ5B	AN30	Watchdog timer 2 over flow (active low)	
Interrupt	NMIRQ	P42	SBT4A	SCL2A	IRQ7A		Non-maskable interrupt request signal input pin (Active low)	
	IRQ15A	P77	SYSCLK	TMMIO			External interrupt request signal input pin 15 (Pin change is possible)	
	IRQ14A	P75	D0	TMMOD5			External interrupt request signal input pin 14 (Pin change is possible)	
	IRQ14B	PK5	SCL5B					
	IRQ13A	P74	D1	TMMOD4			External interrupt request signal input pin 13 (Pin change is possible)	
	IRQ13B	PK4	SDA5B					
	IRQ12A	P73	D2	TMMOD3			External interrupt request signal input pin 12 (Pin change is possible)	
	IRQ12B	PK3						
	IRQ11A	P72	D3	TMMOD2			External interrupt request signal input pin 11 (Pin change is possible)	
	IRQ11B	PK2						
	IRQ10A	P71	D4	TMMOD1			External interrupt request signal input pin 10 (Pin change is possible)	
	IRQ10B	PK1						
	IRQ9A	P70	D5	TMMOD0			External interrupt request signal input pin 9 (Pin change is possible)	
	IRQ9B	PK0						
	IRQ8	P57	A6	NCTS10/ NRTS10	KEY39			External interrupt request signal input pin 8
	IRQ7A	P42	SBT4A	SCL2A	NMIRQ			External interrupt request signal input pin 7 (Pin change is possible)
	IRQ7B	P43	NCTS4/ NRTS4	RTCA				
	IRQ6	P41	SBO4A	SDA2A				External interrupt request signal input pin 6
	IRQ5A	P25	A17	NCTS1/ NRTS1				External interrupt request signal input pin 5 (Pin change is possible)
	IRQ5B	P13	NWE0	TM20IOB	AN30	NWDOVF2		
	IRQ5C	PH1						
	IRQ4A	P24						External interrupt request signal input pin 4 (Pin change is possible)
	IRQ4B	PD7	TM12IOB	KEY23	AN29			
	IRQ4C	PH0						
	IRQ3A	P23	SCL7A					External interrupt request signal input pin 3 (Pin change is possible)
	IRQ3B	PD6	SCL4A	TM12IOA	KEY22	AN28	CRX1A	
	IRQ3C	PG1						
	IRQ2A	P22	NCS2	SDA7A				External interrupt request signal input pin 2 (Pin change is possible)
	IRQ2B	PD5	SDA4A	KEY21	AN27	CTX1A		
	IRQ2C	PG0						
	IRQ1A	P21	NCS1					External interrupt request signal input pin 1 (Pin change is possible)
	IRQ1B	PD4	SCL3A	KEY20	AN26	IRX1A		
	IRQ1C	P97						
IRQ0A	P20	NDK					External interrupt request signal input pin 0 (Pin change is possible)	
IRQ0B	PD3	SDA3A	KEY19	AN25	ITX1A			
IRQ0C	P96							



	Pin	Other Function						Description
Interrupt	KEY0	P60	A5	TM13IOA				Key input interrupt
	KEY1	P61	A4	TM13IOB				
	KEY2	P62	A3	TM14IOA				
	KEY3	P63	A2	TM14IOB				
	KEY4	P64	D9	TM15IOA				
	KEY5	P65	D8	TM15IOB				
	KEY6	P66	D7	TM16IOA				
	KEY7	P67	D6	TM16IOB				
	KEY8	P80	A1	TM3IO	LED0			
	KEY9	P81	A0	TM8IOA	LED1			
	KEY10	P82	D15	TM8IOB	LED2			
	KEY11	P83	D14	TM9IOA	LED3			
	KEY12	P84	D13	TM9IOB	LED4			
	KEY13	P85	D12	TM10IOA	LED5			
	KEY14	P86	D11	TM10IOB	LED6			
	KEY15	P87	D10	TM11IOA	LED7			
	KEY16	PD0	SBO2B	SBO8A	SDA0B	AN22		
	KEY17	PD1	SBI2B	SBI8A	AN23			
	KEY18	PD2	SBT2B	SBT8A	SCL0B	AN24		
	KEY19	PD3	SDA3A	IRQ0B	AN25	ITX1A		
	KEY20	PD4	SCL3A	IRQ1B	AN26	IRX1A		
	KEY21	PD5	SDA4A	IRQ2B	AN27	CTX1A		
	KEY22	PD6	SCL4A	TM12IOA	IRQ3B	AN28	CRX1A	
	KEY23	PD7	TM12IOB	IRQ4B	AN29			
	KEY24	PA0	SBO7A	SBCS11_4	AN0			
	KEY25	PA1	SBI7A	SBCS11_3	AN1	DAOUT0A		
	KEY26	PA2	SBT7A	SBCS11_2	AN2			
	KEY27	PA3	SDA5A	SBCS11_1	TM22IOA	AN3	DAOUT0B	
	KEY28	PA4	SCL5A	SBCS11_0	TM21BKA	AN4		
	KEY29	PA5	SBO11	TM21GCP A	AN5	DAOUT0C		
	KEY30	PA6	SBI11	TM21IOA	AN6			
	KEY31	PA7	SBT11	TM20IOA	AN7			
	KEY32	P50	A16	TM4IOB				
	KEY33	P51	A12	SBO9	NCTS3/ NRTS3			
	KEY34	P52	A11	SBI9				
	KEY35	P53	A10	SBT9				
	KEY36	P54	A9	NCTS9/ NRTS9	SBO10			
	KEY37	P55	A8	SBI10				
	KEY38	P56	A7	SBT10				
KEY39	P57	A6	NCTS10/ NRTS10	IRQ8				
Timer	TM0IO	P10	AN14	OCD_SDA			8-bit Timer 0 to 4 I/O pins	
	TM1IO	P11	AN15	OCD_SCL				
	TM2IO	P12	TM22IOB					
	TM3IO	P80	A1	KEY8	LED0			
	TM4IOA	P34	A14	SBI3A				
	TM4IOB	P50	A16	KEY32				
	TM7IOA	P00	SBO1B	SBO6A	AN8		16-bit Timer 7 I/O pin A, output pin B, C	
	TM7OB	P01	SBI1B	SBI6A	AN9	DAOUT1A		
	TM7OC	P02	SBT1B	SBT6A	NCTS2/ NRTS2	AN10		

	Pin	Other Function					Description	
Timer	TM8IOA	P81	A0	KEY9	LED1		16-bit Timer 8 to 19 I/O pins A, B	
	TM8IOB	P82	D15	KEY10	LED2			
	TM9IOA	P83	D14	KEY11	LED3			
	TM9IOB	P84	D13	KEY12	LED4			
	TM10IOA	P85	D12	KEY13	LED5			
	TM10IOB	P86	D11	KEY14	LED6			
	TM11IOA	P87	D10	KEY15	LED7			
	TM11IOB	P40	SBI4A					
	TM12IOA	PD6	SCL4A	IRQ3B	KEY22	AN28		CRX1A
	TM12IOB	PD7	IRQ4B	KEY23	AN29			
	TM13IOA	P60	A5	KEY0				
	TM13IOB	P61	A4	KEY1				
	TM14IOA	P62	A3	KEY2				
	TM14IOB	P63	A2	KEY3				
	TM15IOA	P64	D9	KEY4				
	TM15IOB	P65	D8	KEY5				
	TM16IOA	P66	D7	KEY6				
	TM16IOB	P67	D6	KEY7				
	TM17IOA	P90	SBO0B	SDA6A	AN16	CTX0A		LINTXDB
	TM18IOA	P92	SBT0B	SCL6A	AN18			
	TM19IOA	P94	SBI3B	AN20	ITX0A			
	TM20IOA	PA7	SBT11	KEY31	AN7			
	TM20IOB	P13	NWE0	IRQ5B	AN30	NWDOVF2		
	TM21IOA	PA6	SBI11	KEY30	AN6			
	TM21IOB	PB2	SBT4C					
	TM22IOA	PA3	SDA5A	SBCS11_1	KEY27	AN3		DAOUT0B
TM22IOB	P12	TM2IO						
TM21BKA	PA4	SCL5A	SBCS11_0	KEY28	AN4			
TM21BKB	PB1	SBI4C						
TM21GCPA	PA5	SBO11	KEY29	AN5	DAOUT0C			
TM21GCPB	PB0	SBO4C						
TMMOD0	P70	D5	IRQ9A					
TMMOD1	P71	D4	IRQ10A					
TMMOD2	P72	D3	IRQ11A					
TMMOD3	P73	D2	IRQ12A					
TMMOD4	P74	D1	IRQ13A					
TMMOD5	P75	D0	IRQ14A					
TMMIO	P77	SYCLK	IRQ15A					
Serial	SBT0A	P16					Serial clock I/O pins (Pin change is possible) - Clock synchronous/UART	
	SBT0B	P92	SCL6A	TM18IOA	AN18			
	SBT1A	P32	A18					
	SBT1B	P02	SBT6A	NCTS2/ NRTS2	TM7OC	AN10		
	SBT2A	P05	SBT5A	SCL0A	AN13	DAOUT1C		
	SBT2B	PD2	SBT8A	SCL0B	KEY18	AN24		
	SBT3A	P35	A13	SCL1A				
	SBT3B	P95	SCL1B	AN21	IRX0A			
	SBT4A	P42	SCL2A	IRQ7A	NMIRQ			
	SBT4B	PC2	SBT7B	SCL2B				
	SBT4C	PB2	TM21IOB					
	SBT5A	P05	SCL0A	SBT2A	AN13	DAOUT1C		
	SBT5B	PF2						
	SBT6A	P02	SBT1B	NCTS2/ NRTS2	TM7OC	AN10		
	SBT6B	PF5	SBCS11_6					
SBT7A	PA2	SBCS11_2	KEY26	AN2				



Serial	Pin	Other Function						Description	
	SBT7B	PC2	SBT4B	SCL2B				Serial clock I/O pins (Pin change is possible) - Clock synchronous/UART	
	SBT8A	PD2	SBT2B	SCL0B	KEY18	AN24			
	SBT8B	PB5							
	SBT9	P53	A10	KEY35					
	SBT10	P56	A7	KEY38					
	SBT11	PA7	TM20IOA	KEY31	AN7				
	SBO0A	P14	NWE1	LINTXDA				Serial data output pins (Pin change is possible) - Clock synchronous/UART	
	SBO0B	P90	SDA6A	TM17IOA	AN16	CTX0A	LINTXDB		
	SBO1A	P30	A20						
	SBO1B	P00	SBO6A	TM7IOA	AN8				
	SBO2A	P03	SBO5A	SDA0A	AN11	DAOUT1B			
	SBO2B	PD0	SBO8A	SDA0B	KEY16	AN22			
	SBO3A	P33	A15	SDA1A					
	SBO3B	P93	SDA1B	AN19					
	SBO4A	P41	SDA2A	IRQ6					
	SBO4B	PC0	SBO7B	SDA2B					
	SBO4C	PB0	TM21GCP B						
	SBO5A	P03	SDA0A	SBO2A	AN11	DAOUT1B			
	SBO5B	PF0							
	SBO6A	P00	SBO1B	TM7IOA	AN8				
	SBO6B	PF3							
	SBO7A	PA0	SBCS11_4	KEY24	AN0				
	SBO7B	PC0	SBO4B	SDA2B					
	SBO8A	PD0	SBO2B	SDA0B	KEY16	AN22			
	SBO8B	PB3							
	SBO9	P51	A12	NCTS3/ NRTS3	KEY33				
	SBO10	P54	A9	NCTS9/ NRTS9	KEY36				
	SBO11	PA5	TM21GCP A	KEY29	AN5	DAOUT0C			
	SBI0A	P15	NRE	AN31	LINRXDA				Serial data input pins (Pin change is possible) - Clock synchronous/UART
	SBI0B	P91	AN17	CRX0A	LINRXDB				
	SBI1A	P31	A19						
	SBI1B	P01	SBI6A	TM7OB	AN9	DAOUT1A			
	SBI2A	P04	SBI5A	AN12					
	SBI2B	PD1	SBI8A	KEY17	AN23				
	SBI3A	P34	A14	TM4IOA					
	SBI3B	P94	TM19IOA	AN20	ITX0A				
	SBI4A	P40	TM11IOB						
	SBI4B	PC1	SBI7B						
	SBI4C	PB1	TM21BKB						
	SBI5A	P04	SBI2A	AN12					
	SBI5B	PF1							
	SBI6A	P01	SBI1B	TM7OB	AN9	DAOUT1A			
	SBI6B	PF4	SBCS11_7						
	SBI7A	PA1	SBCS11_3	KEY25	AN1	DAOUT0A			
	SBI7B	PC1	SBI4B						
	SBI8A	PD1	SBI2B	KEY17	AN23				
	SBI8B	PB4							
	SBI9	P52	A11	KEY34					
	SBI10	P55	A8	KEY37					
	SBI11	PA6	TM21IOA	KEY30	AN6				



	Pin	Other Function					Description	
Serial	SBCS11_7	PF4	SBI6B				4-wire serial chip select pins - Clock synchronous	
	SBCS11_6	PF5	SBT6B					
	SBCS11_5	PF6						
	SBCS11_4	PA0	SBO7A	KEY24	AN0			
	SBCS11_3	PA1	SBI7A	KEY25	AN1	DAOUT0A		
	SBCS11_2	PA2	SBT7A	KEY26	AN2			
	SBCS11_1	PA3	SDA5A	TM22IOA	KEY27	AN3		DAOUT0B
	SBCS11_0	PA4	SCL5A	TM21BKA	KEY28	AN4		
NCTS1/ NRTS1	P25	A17	IRQ5A				CTS/RTS I/O pins	
	NCTS2/ NRTS2	P02	SBT1B	SBT6A	TM7OC	AN10		
	NCTS3/ NRTS3	P51	A12	SBO9	KEY33			
	NCTS4/ NRTS4	P43	IRQ7B	RTCA				
	NCTS9/ NRTS9	P54	A9	SBO10	KEY36			
	NCTS10/ NRTS10	P57	A6	IRQ8	KEY39			
IIC	SCL0A	P05	SBT5A	SBT2A	AN13	DAOUT1C	IIC clock I/O pins (Pin change is possible)	
	SCL0B	PD2	SBT2B	SBT8A	KEY18	AN24		
	SCL1A	P35	A13	SBT3A				
	SCL1B	P95	SBT3B	AN21	IRX0A			
	SCL2A	P42	SBT4A	IRQ7A	NMIRQ			
	SCL2B	PC2	SBT4B	SBT7B				
	SCL3A	PD4	IRQ1B	KEY20	AN26	IRX1A		
	SCL3B	PJ4						
	SCL4A	PD6	TM12IOA	IRQ3B	KEY22	AN28		CRX1A
	SCL4B	PJ7						
	SCL5A	PA4	SBCS11_0	TM21BKA	KEY28	AN4		
	SCL5B	PK5	IRQ14B					
	SCL6A	P92	SBT0B	TM18IOA	AN18			
	SCL6B	PL3						
	SCL7A	P23	IRQ3A					
	SCL7B	PL7						
	SDA0A	P03	SBO5A	SBO2A	AN11	DAOUT1B	IIC data I/O pins (Pin change is possible)	
	SDA0B	PD0	SBO2B	SBO8A	KEY16	AN22		
	SDA1A	P33	A15	SBO3A				
	SDA1B	P93	SBO3B	AN19				
	SDA2A	P41	SBO4A	IRQ6				
	SDA2B	PC0	SBO4B	SBO7B				
	SDA3A	PD3	IRQ0B	KEY19	AN25	ITX1A		
	SDA3B	PJ3						
	SDA4A	PD5	IRQ2B	KEY21	AN27	CTX1A		
	SDA4B	PJ6						
	SDA5A	PA3	SBCS11_1	TM22IOA	KEY27	AN3		DAOUT0B
	SDA5B	PK4	IRQ13B					
SDA6A	P90	SBO0B	TM17IOA	AN16	CTX0A	LINTXDB		
SDA6B	PL2							
SDA7A	P22	NCS2	IRQ2A					
SDA7B	PL6							

	Pin	Other Function						Description
LIN	LINTXDA	P14	SBO0A	NWE1				LIN data transmission pins (Pin change is possible)
	LINTXDB	P90	SBO0B	SDA6A	TM17IOA	AN16	(CTX0A) *2	
	LINRXDA	P15	SBI0A	NRE	AN31			LIN data reception pins (Pin change is possible)
	LINRXDB	P91	SBI0B	AN17	(CRX0A) *2			
CAN *2	CTX0A	P90	SBO0B	SDA6A	TM17IOA	AN16	LINTXDB	CAN data transmission pin (Pin change is possible)
	CTX0B	PE0						
	CTX1A	PD5	SDA4A	IRQ2B	KEY21	AN27		
	CTX1B	PC3						
	CRX0A	P91	SBI0B	AN17	LINRXDB			CAN data reception pin (Pin change is possible)
	CRX0B	PE1						
	CRX1A	PD6	SCL4A	TM12IOA	IRQ3B	KEY22	AN28	
	CRX1B	PC4						
IEBus *3	ITX0A	P94	SBI3B	TM19IOA	AN20			IEBus data transmission pin (Pin change is possible)
	ITX0B	PE5						
	ITX1A	PD3	SDA3A	IRQ0B	KEY19	AN25		
	ITX1B	PE3						IEBus data reception pin (Pin change is possible)
	IRX0A	P95	SBT3B	SCL1B	AN21			
	IRX0B	PE6						
	IRX1A	PD4	SCL3A	IRQ1B	KEY20	AN26		
IRX1B	PE4							
A/D converter	AN0	PA0	SBO7A	SBCS11_4	KEY24			Analog input pins
	AN1	PA1	SBI7A	SBCS11_3	KEY25	DAOUT0A		
	AN2	PA2	SBT7A	SBCS11_2	KEY26			
	AN3	PA3	SDA5A	SBCS11_1	TM22IOA	KEY27	DAOUT0B	
	AN4	PA4	SCL5A	SBCS11_0	TM21BKA	KEY28		
	AN5	PA5	SBO11	TM21GCP A	KEY29	DAOUT0C		
	AN6	PA6	SBI11	TM21IOA	KEY30			
	AN7	PA7	SBT11	TM20IOA	KEY31			
	AN8	P00	SBO1B	SBO6A	TM7IOA			
	AN9	P01	SBI1B	SBI6A	TM7OB	DAOUT1A		
	AN10	P02	SBT1B	SBT6A	NCTS2/ NRTS2	TM7OC		
	AN11	P03	SBO5A	SDA0A	SBO2A	DAOUT1B		
	AN12	P04	SBI5A	SBI2A				
	AN13	P05	SBT5A	SCL0A	SBT2A	DAOUT1C		
	AN14	P10	TM0IO	OCD_SDA				
	AN15	P11	TM1IO	OCD_SCL				
	AN16	P90	SBO0B	SDA6A	TM17IOA	CTX0A	LINTXDB	
	AN17	P91	SBI0B	CRX0A	LINRXDB			
	AN18	P92	SBT0B	SCL6A	TM18IOA			
	AN19	P93	SBO3B	SDA1B				
	AN20	P94	SBI3B	TM19IOA	ITX0A			
	AN21	P95	SBT3B	SCL1B	IRX0A			
	AN22	PD0	SBO2B	SBO8A	SDA0B	KEY16		
	AN23	PD1	SBI2B	SBI8A	KEY17			
	AN24	PD2	SBT2B	SBT8A	SCL0B	KEY18		
	AN25	PD3	SDA3A	IRQ0B	KEY19	ITX1A		
	AN26	PD4	SCL3A	IRQ1B	KEY20	IRX1A		
	AN27	PD5	SDA4A	IRQ2B	KEY21	CTX1A		
	AN28	PD6	SCL4A	TM12IOA	IRQ3B	KEY22	CRX1A	
	AN29	PD7	TM12IOB	IRQ4B	KEY23			
	AN30	P13	NWE0	TM20IOB	IRQ5B	NWDOVF2		
AN31	P15	NRE	SBI0A	LINRXDA				



	Pin	Other Function						Description
D/A converter	DAOUT0A	PA1	SBI7A	SBCS11_3	KEY25	AN1		Analog output pins
	DAOUT0B	PA3	SDA5A	SBCS11_1	TM22IOA	KEY27	AN3	
	DAOUT0C	PA5	SBO11	TM21GCP A	KEY29	AN5		
	DAOUT1A	P01	SBI1B	SBI6A	TM7OB	AN9		
	DAOUT1B	P03	SBO5A	SDA0A	SBO2A	AN11		
	DAOUT1C	P05	SBT5A	SCL0A	SBT2A	AN13		
RTC	RTCA	P43	NCTS4/ NRTS4	IRQ7B				Real time clock output pins
	RTCB	PK7						
I/O port	P00	SBO1B	SBO6A	TM7IOA	AN8			General Purpose I/O port 0
	P01	SBI1B	SBI6A	TM7OB	AN9	DAOUT1A		
	P02	SBT1B	SBT6A	NCTS2/ NRTS2	TM7OC	AN10		
	P03	SBO5A	SDA0A	SBO2A	AN11	DAOUT1B		
	P04	SBI5A	SBI2A	AN12				
	P05	SBT5A	SCL0A	SBT2A	AN13	DAOUT1C		
	P06							
	P07							
	P10	TM0IO	AN14	OCD_SDA				General Purpose I/O port 1
	P11	TM1IO	AN15	OCD_SCL				
	P12	TM2IO	TM22IOB					
	P13	NWE0	TM20IOB	IRQ5B	AN30	NWDOVF2		
	P14	NWE1	SBO0A	LINTXDA				
	P15	NRE	SBI0A	AN31	LINRXDA			
	P16	SBT0A						
	P20	NDK	IRQ0A					General Purpose I/O port 2
	P21	NCS1	IRQ1A					
	P22	NCS2	SDA7A	IRQ2A				
	P23	SCL7A	IRQ3A					
	P24	IRQ4A						
	P25	A17	NCTS1/ NRTS1	IRQ5A				
	P30	A20	SBO1A					General Purpose I/O port 3
	P31	A19	SBI1A					
	P32	A18	SBT1A					
	P33	A15	SDA1A	SBO3A				
	P34	A14	SBI3A	TM4IOA				
	P35	A13	SCL1A	SBT3A				
	P40	SBI4A	TM11IOB					General Purpose I/O port 4
	P41	SBO4A	SDA2A	IRQ6				
	P42	SBT4A	SCL2A	IRQ7A	NMIRQ			
	P43	NCTS4/ NRTS4	IRQ7B	RTCA				
	P44	OSCO						
	P45	OSCI						
P46	XI							
P47	XO							



I/O port	Pin	Other Function					Description			
P50-P57	P50	A16	TM4IOB	KEY32			General Purpose I/O port 5			
	P51	A12	SBO9	NCTS3/ NRTS3	KEY33					
	P52	A11	SBI9	KEY34						
	P53	A10	SBT9	KEY35						
	P54	A9	NCTS9/ NRTS9	SBO10	KEY36					
	P55	A8	SBI10	KEY37						
	P56	A7	SBT10	KEY38						
	P57	A6	NCTS10/ NRTS10	IRQ8	KEY39					
	P60	A5	TM13IOA	KEY0				General Purpose I/O port 6		
	P61	A4	TM13IOB	KEY1						
P62	A3	TM14IOA	KEY2							
P63	A2	TM14IOB	KEY3							
P64	D9	TM15IOA	KEY4							
P65	D8	TM15IOB	KEY5							
P66	D7	TM16IOA	KEY6							
P67	D6	TM16IOB	KEY7							
P70-P77	P70	D5	TMMOD0	IRQ9A			General Purpose I/O port 7			
	P71	D4	TMMOD1	IRQ10A						
	P72	D3	TMMOD2	IRQ11A						
	P73	D2	TMMOD3	IRQ12A						
	P74	D1	TMMOD4	IRQ13A						
	P75	D0	TMMOD5	IRQ14A						
	P76									
	P77	YSCLK	TMMIO	IRQ15A						
	P80-P87	P80	A1	TM3IO	KEY8	LED0			General Purpose I/O port 8	
		P81	A0	TM8IOA	KEY9	LED1				
P82		D15	TM8IOB	KEY10	LED2					
P83		D14	TM9IOA	KEY11	LED3					
P84		D13	TM9IOB	KEY12	LED4					
P85		D12	TM10IOA	KEY13	LED5					
P86		D11	TM10IOB	KEY14	LED6					
P87		D10	TM11IOA	KEY15	LED7					
P90-P97		P90	SBO0B	SDA6A	TM17IOA	AN16	CTX0A	LINTXDB		General Purpose I/O port 9
		P91	SBI0B	AN17	CRX0A	LINRXDB				
	P92	SBT0B	SCL6A	TM18IOA	AN18					
	P93	SBO3B	SDA1B	AN19						
	P94	SBI3B	TM19IOA	AN20	ITX0A					
	P95	SBT3B	SCL1B	AN21	IRX0A					
	P96	IRQ0C								
	P97	IRQ1C								
	PA0-PA7	PA0	SBO7A	SBCS11_4	KEY24	AN0			General Purpose I/O port A	
		PA1	SBI7A	SBCS11_3	KEY25	AN1	DAOUT0A			
PA2		SBT7A	SBCS11_2	KEY26	AN2					
PA3		SDA5A	SBCS11_1	TM22IOA	KEY27	AN3	DAOUT0B			
PA4		SCL5A	SBCS11_0	TM21BKA	KEY28	AN4				
PA5		SBO11	TM21GCP A	KEY29	AN5	DAOUT0C				
PA6		SBI11	TM21IOA	KEY30	AN6					
PA7		SBT11	TM20IOA	KEY31	AN7					



I/O port	Pin	Other Function						Description
PB0	PB0	SBO4C	TM21GCP B					General Purpose I/O port B
	PB1	SBI4C	TM21BKB					
	PB2	SBT4C	TM21IOB					
	PB3	SBO8B						
	PB4	SBI8B						
	PB5	SBT8B						
	PB6							
PC0	PC0	SBO4B	SBO7B	SDA2B				General Purpose I/O port C
	PC1	SBI4B	SBI7B					
	PC2	SBT4B	SBT7B	SCL2B				
	PC3	CTX1B						
	PC4	CRX1B						
	PC5							
	PC6							
PD0	PD0	SBO2B	SBO8A	SDA0B	KEY16	AN22		General Purpose I/O port D
	PD1	SBI2B	SBI8A	KEY17	AN23			
	PD2	SBT2B	SBT8A	SCL0B	KEY18	AN24		
	PD3	SDA3A	IRQ0B	KEY19	AN25	ITX1A		
	PD4	SCL3A	IRQ1B	KEY20	AN26	IRX1A		
	PD5	SDA4A	IRQ2B	KEY21	AN27	CTX1A		
	PD6	SCL4A	TM12IOA	IRQ3B	KEY22	AN28	CRX1A	
PE0	PD7	TM12IOB	IRQ4B	KEY23	AN29			General Purpose I/O port E
	PE0	CTX0B						
	PE1	CRX0B						
	PE2							
	PE3	ITX1B						
	PE4	IRX1B						
	PE5	ITX0B						
PF0	PE6	IRX0B						General Purpose I/O port F
	PE7							
	PF0	SBO5B						
	PF1	SBI5B						
	PF2	SBT5B						
	PF3	SBO6B						
	PF4	SBI6B	SBCS11_7					
PG0	PF5	SBT6B	SBCS11_6					General Purpose I/O port G
	PF6	SBCS11_5						
	PG0	IRQ2C						
	PG1	IRQ3C						
	PG2							
	PG3							
	PG4							
PH0	PG5							General Purpose I/O port H
	PG6							
PJ0	PH0	IRQ4C						General Purpose I/O port J
	PH1	IRQ5C						
	PJ0							
	PJ1							
	PJ2							
	PJ3	SDA3B						
	PJ4	SCL3B						
	PJ5							
PJ6	SDA4B							
PJ7	SCL4B							



	Pin	Other Function					Description	
I/O port	PK0	IRQ9B					General Purpose I/O port K	
	PK1	IRQ10B						
	PK2	IRQ11B						
	PK3	IRQ12B						
	PK4	SDA5B	IRQ13B					
	PK5	SCL5B	IRQ14B					
	PK6	IRQ15B						
	PK7	RTCB						
	PL0						General Purpose I/O port L	
	PL1							
	PL2	SDA6B						
	PL3	SCL6B						
	PL4							
	PL5							
	PL6	SDA7B						
	PL7	SCL7B						
	I/O port	PM0						General Purpose I/O port M
		PM1						
		PM2						
PM3								
PM4								
PM5								
PM6								
PM7								
LED	LED0	P80	A1	TM3IO	KEY8		LED drive pins	
	LED1	P81	A0	TM8IOA	KEY9			
	LED2	P82	D15	TM8IOB	KEY10			
	LED3	P83	D14	TM9IOA	KEY11			
	LED4	P84	D13	TM9IOB	KEY12			
	LED5	P85	D12	TM10IOA	KEY13			
	LED6	P86	D11	TM10IOB	KEY14			
	LED7	P87	D10	TM11IOA	KEY15			
OCD	OCD_SDA	P10	TM0IO	AN14			Data I/O pin for on-chip debug function	
	OCD_SCL	P11	TM1IO	AN15			Clock input pin for on-chip debug function	

*1 Refer to [1.8.2 Unused pins] and [1.8.5 Power Supply Circuit] for detail about note of VDD and function control pins.

*2 CAN-embedded series only.

*3 IEBus-embedded series only.



Table:1.5.6 shows pin functions of 144 pin version.

Table:1.5.6 Pin Functions of 144 pin Version

	Pin	Other Function				Description	
Power supply / Ground *1	VDD50					On-chip regulator power supply Power supply for I/O	
	AVDD					Power supply for analog operation.	
	VOU18					Power supply for internal circuit.	
	VREFH					Reference power supply pin for the A/D converter.	
	VSS					Ground	
	AVSS					Ground pin for analog.	
Function control *1	OCDMOD					On-chip debug function (OCD) control pin	
	ATRST					Auto reset setting pin.	
Reset	NRST					Reset signal input pin (Active low)	
Clock	OSCI	P45				High-speed oscillation input pin (clkosc = 4 to 20 MHz)	
	OSCO	P44				High-speed oscillation output pin	
	XI	P46				Low-speed oscillation input pin (clkx = 32.768 kHz)	
	XO	P47				Low-speed oscillation output pin	
	SYSCCLK	P77	TMMIO	IRQ15A			System clock signal output pin
Bus	A20	P30	SBO1A			Address output pins at Memory expansion mode	
	A19	P31	SBI1A				
	A18	P32	SBT1A				
	A17	P25	NCTS1/ NRST1	IRQ5A			
	A16	P50	TM4IOB	KEY32			
	A15	P33	SDA1A	SBO3A			
	A14	P34	SBI3A	TM4IOA			
	A13	P35	SCL1A	SBT3A			
	A12	P51	SBO9	NCTS3/ NRST3	KEY33		
	A11	P52	SBI9	KEY34			
	A10	P53	SBT9	KEY35			
	A9	P54	NCTS9/ NRST9	SBO10	KEY36		
	A8	P55	SBI10	KEY37			
	A7	P56	SBT10	KEY38			
	A6	P57	NCTS10/ NRST10	IRQ8	KEY39		
	A5	P60	TM13IOA	KEY0			
	A4	P61	TM13IOB	KEY1			
	A3	P62	TM14IOA	KEY2			
	A2	P63	TM14IOB	KEY3			
	A1	P80	TM3IO	KEY8	LED0		
	A0	P81	TM8IOA	KEY9	LED1		
	D15	P82	TM8IOB	KEY10	LED2	Data I/O pins at Memory expansion mode	
	D14	P83	TM9IOA	KEY11	LED3		
	D13	P84	TM9IOB	KEY12	LED4		
	D12	P85	TM10IOA	KEY13	LED5		
	D11	P86	TM10IOB	KEY14	LED6		
	D10	P87	TM11IOA	KEY15	LED7		
	D9	P64	TM15IOA	KEY4			
	D8	P65	TM15IOB	KEY5			
	D7	P66	TM16IOA	KEY6			
	D6	P67	TM16IOB	KEY7			
	D5	P70	TMMOD0	IRQ9A			
	D4	P71	TMMOD1	IRQ10A			
D3	P72	TMMOD2	IRQ11A				
D2	P73	TMMOD3	IRQ12A				

	Pin	Other Function					Description
Bus	D1	P74	TMMOD4	IRQ13A			Data I/O pins at Memory expansion mode
	D0	P75	TMMOD5	IRQ14A			
	NCS2	P22	SDA7A	IRQ2A			Chip select signal output pins (Active low)
	NCS1	P21	IRQ1A				
	NRE	P15	SBI0A	AN31	LINRXDA		Read enable signal output pin (Active low)
	NWE1	P14	SBO0A	LINTXDA			Write enable signal output pins (Active low)
	NWE0	P13	TM20IOB	IRQ5B	AN30	NWDOVF2	
	NDK	P20	IRQ0A				Acknowledge signal input pin (Active low)
Watchdog timer 2	NWDOVF2	P13	NWE0	TM20IOB	IRQ5B	AN30	Watchdog timer 2 over flow (Active low)
Interrupt	NMIRQ	P42	SBT4A	SCL2A	IRQ7A		Non-maskable interrupt request signal input pin (Active low)
	IRQ15A	P77	SYSCLK	TMMIO			External interrupt request signal input pin 15
	IRQ14A	P75	D0	TMMOD5			External interrupt request signal input pin 14
	IRQ13A	P74	D1	TMMOD4			External interrupt request signal input pin 13
	IRQ12A	P73	D2	TMMOD3			External interrupt request signal input pin 12
	IRQ11A	P72	D3	TMMOD2			External interrupt request signal input pin 11
	IRQ10A	P71	D4	TMMOD1			External interrupt request signal input pin 10
	IRQ9A	P70	D5	TMMOD0			External interrupt request signal input pin 9
	IRQ8	P57	A6	NCTS10/ NRTS10	KEY39		External interrupt request signal input pin 8
	IRQ7A	P42	SBT4A	SCL2A	NMIRQ		External interrupt request signal input pin 7 (Pin change is possible)
	IRQ7B	P43	NCTS4/ NRTS4	RTCA			
	IRQ6	P41	SBO4A	SDA2A			External interrupt request signal input pin 6
	IRQ5A	P25	A17	NCTS1/ NRTS1			External interrupt request signal input pin 5 (Pin change is possible)
	IRQ5B	P13	NWE0	TM20IOB	AN30	NWDOVF2	
	IRQ5C	PH1					
	IRQ4A	P24					External interrupt request signal input pin 4 (Pin change is possible)
	IRQ4B	PD7	TM12IOB	KEY23	AN29		
	IRQ4C	PH0					
	IRQ3A	P23	SCL7A				External interrupt request signal input pin 3 (Pin change is possible)
	IRQ3B	PD6	SCL4A	TM12IOA	KEY22	AN28	CRX1A
	IRQ3C	PG1					
	IRQ2A	P22	NCS2	SDA7A			
IRQ2B	PD5	SDA4A	KEY21	AN27	CTX1A		
IRQ2C	PG0						
IRQ1A	P21	NCS1					
IRQ1B	PD4	SCL3A	KEY20	AN26	IRX1A		
IRQ1C	P97						
Interrupt	IRQ0A	P20	NDK				External interrupt request signal input pin 0 (Pin change is possible)
	IRQ0B	PD3	SDA3A	KEY19	AN25	ITX1A	
	IRQ0C	P96					
	KEY0	P60	A5	TM13IOA			Key input interrupt
	KEY1	P61	A4	TM13IOB			
	KEY2	P62	A3	TM14IOA			
	KEY3	P63	A2	TM14IOB			
	KEY4	P64	D9	TM15IOA			
	KEY5	P65	D8	TM15IOB			
	KEY6	P66	D7	TM16IOA			
	KEY7	P67	D6	TM16IOB			
	KEY8	P80	A1	TM3IO	LED0		
	KEY9	P81	A0	TM8IOA	LED1		
	KEY10	P82	D15	TM8IOB	LED2		
	KEY11	P83	D14	TM9IOA	LED3		
KEY12	P84	D13	TM9IOB	LED4			

	Pin	Other Function						Description			
Interrupt	KEY13	P85	D12	TM10IOA	LED5			Key input interrupt			
	KEY14	P86	D11	TM10IOB	LED6						
	KEY15	P87	D10	TM11IOA	LED7						
	KEY16	PD0	SBO2B	SBO8A	SDA0B	AN22					
	KEY17	PD1	SBI2B	SBI8A	AN23						
	KEY18	PD2	SBT2B	SBT8A	SCL0B	AN24					
	KEY19	PD3	SDA3A	IRQ0B	AN25	ITX1A					
	KEY20	PD4	SCL3A	IRQ1B	AN26	IRX1A					
	KEY21	PD5	SDA4A	IRQ2B	AN27	CTX1A					
	KEY22	PD6	SCL4A	TM12IOA	IRQ3B	AN28	CRX1A				
	KEY23	PD7	TM12IOB	IRQ4B	AN29						
	KEY24	PA0	SBO7A	SBCS11_4	AN0						
	KEY25	PA1	SBI7A	SBCS11_3	AN1	DAOUT0A					
	KEY26	PA2	SBT7A	SBCS11_2	AN2						
	KEY27	PA3	SDA5A	SBCS11_1	TM22IOA	AN3	DAOUT0B				
	KEY28	PA4	SCL5A	SBCS11_0	TM21BKA	AN4					
	KEY29	PA5	SBO11	TM21GCPA	AN5	DAOUT0C					
	KEY30	PA6	SBI11	TM21IOA	AN6						
	KEY31	PA7	SBT11	TM20IOA	AN7						
	KEY32	P50	A16	TM4IOB							
	KEY33	P51	A12	SBO9	NCTS3/ NRTS3						
	KEY34	P52	A11	SBI9							
	KEY35	P53	A10	SBT9							
	KEY36	P54	A9	NCTS9/ NRTS9	SBO10						
	KEY37	P55	A8	SBI10							
	KEY38	P56	A7	SBT10							
	KEY39	P57	A6	NCTS10/ NRTS10	IRQ8						
	Timer	TM0IO	P10	AN14	OCD_SDA					8-bit Timer 0 to 4 I/O pins	
		TM1IO	P11	AN15	OCD_SCL						
		TM2IO	P12	TM22IOB							
		TM3IO	P80	A1	KEY8	LED0					
		TM4IOA	P34	A14	SBI3A						
		TM4IOB	P50	A16	KEY32						
		TM7IOA	P00	SBO1B	SBO6A	AN8					16-bit Timer 7 I/O pin A, output pin B, C
		TM7OB	P01	SBI1B	SBI6A	AN9	DAOUT1A				
		TM7OC	P02	SBT1B	SBT6A	NCTS2/ NRTS2	AN10				
	Timer	TM8IOA	P81	A0	KEY9	LED1				16-bit Timer 8 to 19 I/O pins A, B	
		TM8IOB	P82	D15	KEY10	LED2					
		TM9IOA	P83	D14	KEY11	LED3					
TM9IOB		P84	D13	KEY12	LED4						
TM10IOA		P85	D12	KEY13	LED5						
TM10IOB		P86	D11	KEY14	LED6						
TM11IOA		P87	D10	KEY15	LED7						
TM11IOB		P40	SBI4A								
TM12IOA		PD6	SCL4A	IRQ3B	KEY22	AN28	CRX1A				
TM12IOB		PD7	IRQ4B	KEY23	AN29						
TM13IOA		P60	A5	KEY0							
TM13IOB		P61	A4	KEY1							
TM14IOA		P62	A3	KEY2							
TM14IOB		P63	A2	KEY3							
TM15IOA		P64	D9	KEY4							
TM15IOB		P65	D8	KEY5							
TM16IOA	P66	D7	KEY6								

	Pin	Other Function						Description		
Timer	TM16IOB	P67	D6	KEY7				16-bit Timer 8 to 19 I/O pins A, B		
	TM17IOA	P90	SBO0B	SDA6A	AN16	CTX0A	LINTXDB			
	TM18IOA	P92	SBT0B	SCL6A	AN18					
	TM19IOA	P94	SBI3B	AN20	ITX0A					
	TM20IOA	PA7	SBT11	KEY31	AN7			8-bit Timer 20 to 22 I/O pins (Pin change is possible)		
	TM20IOB	P13	NWE0	IRQ5B	AN30	NWDOVF2				
	TM21IOA	PA6	SBI11	KEY30	AN6					
	TM21IOB	PB2	SBT4C							
	TM22IOA	PA3	SDA5A	SBCS11_1	KEY27	AN3	DAOUT0B			
	TM22IOB	P12	TM2IO					8-bit Timer 21 I/O pins (Pin change is possible)		
	TM21BKA	PA4	SCL5A	SBCS11_0	KEY28	AN4				
	TM21BKB	PB1	SBI4C							
	TM21GCPA	PA5	SBO11	KEY29	AN5	DAOUT0C				
	TM21GCPB	PB0	SBO4C							
	TMMOD	TMMOD0	P70	D5	IRQ9A				Motor control 16-bit Timer I/O pins	
		TMMOD1	P71	D4	IRQ10A					
		TMMOD2	P72	D3	IRQ11A					
		TMMOD3	P73	D2	IRQ12A					
		TMMOD4	P74	D1	IRQ13A					
TMMOD5		P75	D0	IRQ14A						
TMMIO		P77	SYSCLK	IRQ15A						
Serial		SBT0A	P16							Serial clock I/O pins (Pin change is possible) - Clock synchronous/UART
		SBT0B	P92	SCL6A	TM18IOA	AN18				
	SBT1A	P32	A18							
	SBT1B	P02	SBT6A	NCTS2/ NRTS2	TM7OC	AN10				
	SBT2A	P05	SBT5A	SCL0A	AN13	DAOUT1C				
	SBT2B	PD2	SBT8A	SCL0B	KEY18	AN24				
	SBT3A	P35	A13	SCL1A						
	SBT3B	P95	SCL1B	AN21	IRX0A					
	SBT4A	P42	SCL2A	IRQ7A	NMIRQ					
	SBT4B	PC2	SBT7B	SCL2B						
	SBT4C	PB2	TM21IOB							
	SBT5A	P05	SCL0A	SBT2A	AN13	DAOUT1C				
	SBT5B	PF2								
	SBT6A	P02	SBT1B	NCTS2/ NRTS2	TM7OC	AN10				
	SBT6B	PF5	SBCS11_6							
	SBT7A	PA2	SBCS11_2	KEY26	AN2					
	SBT7B	PC2	SBT4B	SCL2B						
	SBT8A	PD2	SBT2B	SCL0B	KEY18	AN24				
	SBT8B	PB5								
	SBT9	P53	A10	KEY35						
	SBT10	P56	A7	KEY38						
	SBT11	PA7	TM20IOA	KEY31	AN7					
	SBO0A	P14	NWE1	LINTXDA				Serial data output pins (Pin change is possible) - Clock synchronous/UART		
	SBO0B	P90	SDA6A	TM17IOA	AN16	CTX0A	LINTXDB			
	SBO1A	P30	A20							
	SBO1B	P00	SBO6A	TM7IOA	AN8					
	SBO2A	P03	SBO5A	SDA0A	AN11	DAOUT1B				
	SBO2B	PD0	SBO8A	SDA0B	KEY16	AN22				
	SBO3A	P33	A15	SDA1A						
	SBO3B	P93	SDA1B	AN19						
	SBO4A	P41	SDA2A	IRQ6						
	SBO4B	PC0	SBO7B	SDA2B						
SBO4C	PB0	TM21GCPB								

Serial	Pin	Other Function						Description
	SBO5A	P03	SDA0A	SBO2A	AN11	DAOUT1B	Serial data output pins (Pin change is possible) - Clock synchronous/UART	
	SBO5B	PF0						
	SBO6A	P00	SBO1B	TM7IOA	AN8			
	SBO6B	PF3						
	SBO7A	PA0	SBCS11_4	KEY24	AN0			
	SBO7B	PC0	SBO4B	SDA2B				
	SBO8A	PD0	SBO2B	SDA0B	KEY16	AN22		
	SBO8B	PB3						
	SBO9	P51	A12	NCTS3/ NRTS3	KEY33			
	SBO10	P54	A9	NCTS9/ NRTS9	KEY36			
	SBO11	PA5	TM21GCPA	KEY29	AN5	DAOUT0C		
	SBI0A	P15	NRE	AN31	LINRXDA		Serial data input pins (Pin change is possible) - Clock synchronous/UART	
	SBI0B	P91	AN17	CRX0A	LINRXDB			
	SBI1A	P31	A19					
	SBI1B	P01	SBI6A	TM7OB	AN9	DAOUT1A		
	SBI2A	P04	SBI5A	AN12				
	SBI2B	PD1	SBI8A	KEY17	AN23			
	SBI3A	P34	A14	TM4IOA				
	SBI3B	P94	TM19IOA	AN20	ITX0A			
	SBI4A	P40	TM11IOB					
	SBI4B	PC1	SBI7B					
	SBI4C	PB1	TM21BKB					
	SBI5A	P04	SBI2A	AN12				
	SBI5B	PF1						
	SBI6A	P01	SBI1B	TM7OB	AN9	DAOUT1A		
	SBI6B	PF4	SBCS11_7					
	SBI7A	PA1	SBCS11_3	KEY25	AN1	DAOUT0A		
	SBI7B	PC1	SBI4B					
	SBI8A	PD1	SBI2B	KEY17	AN23			
	SBI8B	PB4						
	SBI9	P52	A11	KEY34				
	SBI10	P55	A8	KEY37				
	SBI11	PA6	TM21IOA	KEY30	AN6			
	SBCS11_7	PF4	SBI6B					4-wire serial chip select pins - Clock synchronous
	SBCS11_6	PF5	SBT6B					
	SBCS11_5	PF6						
	SBCS11_4	PA0	SBO7A	KEY24	AN0			
	SBCS11_3	PA1	SBI7A	KEY25	AN1	DAOUT0A		
	SBCS11_2	PA2	SBT7A	KEY26	AN2			
	SBCS11_1	PA3	SDA5A	TM22IOA	KEY27	AN3	DAOUT0B	
	SBCS11_0	PA4	SCL5A	TM21BKA	KEY28	AN4		
	NCTS1/ NRTS1	P25	A17	IRQ5A			CTS/RTS I/O pins	
	NCTS2/ NRTS2	P02	SBT1B	SBT6A	TM7OC	AN10		
	NCTS3/ NRTS3	P51	A12	SBO9	KEY33			
	NCTS4/ NRTS4	P43	IRQ7B	RTCA				
	NCTS9/ NRTS9	P54	A9	SBO10	KEY36			
	NCTS10/ NRTS10	P57	A6	IRQ8	KEY39			

	Pin	Other Function						Description
IIC	SCL0A	P05	SBT5A	SBT2A	AN13	DAOUT1C		IIC clock I/O pins
	SCL0B	PD2	SBT2B	SBT8A	KEY18	AN24		
	SCL1A	P35	A13	SBT3A				
	SCL1B	P95	SBT3B	AN21	IRX0A			
	SCL2A	P42	SBT4A	IRQ7A	NMIRQ			
	SCL2B	PC2	SBT4B	SBT7B				
	SCL3A	PD4	IRQ1B	KEY20	AN26	IRX1A		
	SCL4A	PD6	TM12IOA	IRQ3B	KEY22	AN28	CRX1A	
	SCL5A	PA4	SBCS11_0	TM21BKA	KEY28	AN4		
	SCL6A	P92	SBT0B	TM18IOA	AN18			
	SCL7A	P23	IRQ3A					
	SDA0A	P03	SBO5A	SBO2A	AN11	DAOUT1B		IIC data I/O pins (Pin change is possible)
	SDA0B	PD0	SBO2B	SBO8A	KEY16	AN22		
	SDA1A	P33	A15	SBO3A				
	SDA1B	P93	SBO3B	AN19				
	SDA2A	P41	SBO4A	IRQ6				
SDA2B	PC0	SBO4B	SBO7B					
SDA3A	PD3	IRQ0B	KEY19	AN25	ITX1A			
SDA4A	PD5	IRQ2B	KEY21	AN27	CTX1A			
SDA5A	PA3	SBCS11_1	TM22IOA	KEY27	AN3	DAOUT0B	IIC data I/O pins (Pin change is possible)	
SDA6A	P90	SBO0B	TM17IOA	AN16	CTX0A	LINTXDB		
SDA7A	P22	NCS2	IRQ2A					
LIN	LINTXDA	P14	SBO0A	NWE1				LIN data transmission pins (Pin change is possible)
	LINTXDB	P90	SBO0B	SDA6A	TM17IOA	AN16	(CTX0A) *2	
	LINRXDA	P15	SBI0A	NRE	AN31			LIN data reception pins (Pin change is possible)
	LINRXDB	P91	SBI0B	AN17	(CRX0A) *2			
CAN *2	CTX0A	P90	SBO0B	SDA6A	TM17IOA	AN16	LINTXDB	CAN data transmission pin (Pin change is possible)
	CTX0B	PE0						
	CTX1A	PD5	SDA4A	IRQ2B	KEY21	AN27		
	CTX1B	PC3						CAN data reception pin (Pin change is possible)
	CRX0A	P91	SBI0B	AN17	LINRXDB			
	CRX0B	PE1						
	CRX1A	PD6	SCL4A	TM12IOA	IRQ3B	KEY22	AN28	
CRX1B	PC4							
IEBus *3	ITX0A	P94	SBI3B	TM19IOA	AN20			IEBus data transmission pin (Pin change is possible)
	ITX0B	PE5						
	ITX1A	PD3	SDA3A	IRQ0B	KEY19	AN25		
	ITX1B	PE3						
	IRX0A	P95	SBT3B	SCL1B	AN21			IEBus data reception pin (Pin change is possible)
	IRX0B	PE6						
	IRX1A	PD4	SCL3A	IRQ1B	KEY20	AN26		
	IRX1B	PE4						
A/D converter	AN0	PA0	SBO7A	SBCS11_4	KEY24			Analog input pins
	AN1	PA1	SBI7A	SBCS11_3	KEY25	DAOUT0A		
	AN2	PA2	SBT7A	SBCS11_2	KEY26			
	AN3	PA3	SDA5A	SBCS11_1	TM22IOA	KEY27	DAOUT0B	
	AN4	PA4	SCL5A	SBCS11_0	TM21BKA	KEY28		
	AN5	PA5	SBO11	TM21GCPA	KEY29	DAOUT0C		
	AN6	PA6	SBI11	TM21IOA	KEY30			
	AN7	PA7	SBT11	TM20IOA	KEY31			
	AN8	P00	SBO1B	SBO6A	TM7IOA			
	AN9	P01	SBI1B	SBI6A	TM7OB	DAOUT1A		
	AN10	P02	SBT1B	SBT6A	NCTS2/ NRTS2	TM7OC		



	Pin	Other Function						Description
A/D converter	AN11	P03	SBO5A	SDA0A	SBO2A	DAOUT1B		Analog input pins
	AN12	P04	SBI5A	SBI2A				
	AN13	P05	SBT5A	SCL0A	SBT2A	DAOUT1C		
	AN14	P10	TM0IO	OCD_SDA				
	AN15	P11	TM1IO	OCD_SCL				
	AN16	P90	SBO0B	SDA6A	TM17IOA	CTX0A	LINTXDB	
	AN17	P91	SBI0B	CRX0A	LINRXDB			
	AN18	P92	SBT0B	SCL6A	TM18IOA			
	AN19	P93	SBO3B	SDA1B				
	AN20	P94	SBI3B	TM19IOA	ITX0A			
	AN21	P95	SBT3B	SCL1B	IRX0A			
	AN22	PD0	SBO2B	SBO8A	SDA0B	KEY16		
	AN23	PD1	SBI2B	SBI8A	KEY17			
	AN24	PD2	SBT2B	SBT8A	SCL0B	KEY18		
	AN25	PD3	SDA3A	IRQ0B	KEY19	ITX1A		
	AN26	PD4	SCL3A	IRQ1B	KEY20	IRX1A		
	AN27	PD5	SDA4A	IRQ2B	KEY21	CTX1A		
	AN28	PD6	SCL4A	TM12IOA	IRQ3B	KEY22	CRX1A	
	AN29	PD7	TM12IOB	IRQ4B	KEY23			
	AN30	P13	NWE0	TM20IOB	IRQ5B	NWDOVF2		
AN31	P15	NRE	SBI0A	LINRXDA				
D/A converter	DAOUT0A	PA1	SBI7A	SBCS11_3	KEY25	AN1		Analog output pins
	DAOUT0B	PA3	SDA5A	SBCS11_1	TM22IOA	KEY27	AN3	
	DAOUT0C	PA5	SBO11	TM21GCPA	KEY29	AN5		
	DAOUT1A	P01	SBI1B	SBI6A	TM7OB	AN9		
	DAOUT1B	P03	SBO5A	SDA0A	SBO2A	AN11		
	DAOUT1C	P05	SBT5A	SCL0A	SBT2A	AN13		
RTC	RTCA	P43	NCTS4/ NRTS4	IRQ7B				Real time clock output pins
I/O port	P00	SBO1B	SBO6A	TM7IOA	AN8			General Purpose I/O port 0
	P01	SBI1B	SBI6A	TM7OB	AN9	DAOUT1A		
	P02	SBT1B	SBT6A	NCTS2/ NRTS2	TM7OC	AN10		
	P03	SBO5A	SDA0A	SBO2A	AN11	DAOUT1B		
	P04	SBI5A	SBI2A	AN12				
	P05	SBT5A	SCL0A	SBT2A	AN13	DAOUT1C		
	P06							
	P07							
	P10	TM0IO	AN14	OCD_SDA				General Purpose I/O port 1
	P11	TM1IO	AN15	OCD_SCL				
	P12	TM2IO	TM22IOB					
	P13	NWE0	TM20IOB	IRQ5B	AN30	NWDOVF2		
	P14	NWE1	SBO0A	LINTXDA				
	P15	NRE	SBI0A	AN31	LINRXDA			
	P16	SBT0A						
I/O port	P20	NDK	IRQ0A					General Purpose I/O port 2
	P21	NCS1	IRQ1A					
	P22	NCS2	SDA7A	IRQ2A				
	P23	SCL7A	IRQ3A					
	P24	IRQ4A						
	P25	A17	NCTS1/ NRTS1	IRQ5A				



I/O port	Pin	Other Function					Description
P30-P35	P30	A20	SBO1A				General Purpose I/O port 3
	P31	A19	SBI1A				
	P32	A18	SBT1A				
	P33	A15	SDA1A	SBO3A			
	P34	A14	SBI3A	TM4IOA			
	P35	A13	SCL1A	SBT3A			
	P40	SBI4A	TM11IOB				
P41	SBO4A	SDA2A	IRQ6				
P42	SBT4A	SCL2A	IRQ7A	NMIRQ			
P43	NCTS4/ NRTS4	IRQ7B	RTCA				
P44	OSCO						
P45	OSCI						
P46	XI						
P47	XO					General Purpose I/O port 5	
P50	A16	TM4IOB	KEY32				
P51	A12	SBO9	NCTS3/ NRTS3	KEY33			
P52	A11	SBI9	KEY34				
P53	A10	SBT9	KEY35				
P54	A9	NCTS9/ NRTS9	SBO10	KEY36			
P55	A8	SBI10	KEY37				
P56	A7	SBT10	KEY38			General Purpose I/O port 6	
P57	A6	NCTS10/ NRTS10	IRQ8	KEY39			
P60	A5	TM13IOA	KEY0				
P61	A4	TM13IOB	KEY1				
P62	A3	TM14IOA	KEY2				
P63	A2	TM14IOB	KEY3				
P64	D9	TM15IOA	KEY4				
P65	D8	TM15IOB	KEY5			General Purpose I/O port 7	
P66	D7	TM16IOA	KEY6				
P67	D6	TM16IOB	KEY7				
P70	D5	TMMOD0	IRQ9A				
P71	D4	TMMOD1	IRQ10A				
P72	D3	TMMOD2	IRQ11A				
P73	D2	TMMOD3	IRQ12A				
P74	D1	TMMOD4	IRQ13A			General Purpose I/O port 8	
P75	D0	TMMOD5	IRQ14A				
P76							
P77	SYSCLK	TMMIO	IRQ15A			General Purpose I/O port 8	
P80	A1	TM3IO	KEY8	LED0			
P81	A0	TM8IOA	KEY9	LED1			
P82	D15	TM8IOB	KEY10	LED2			
P83	D14	TM9IOA	KEY11	LED3			
P84	D13	TM9IOB	KEY12	LED4			
P85	D12	TM10IOA	KEY13	LED5			
P86	D11	TM10IOB	KEY14	LED6			
P87	D10	TM11IOA	KEY15	LED7			



I/O port	Pin	Other Function						Description
P90	P90	SBO0B	SDA6A	TM17IOA	AN16	CTX0A	LINTXDB	General Purpose I/O port 9
	P91	SBI0B	AN17	CRX0A	LINRXDB			
	P92	SBT0B	SCL6A	TM18IOA	AN18			
	P93	SBO3B	SDA1B	AN19				
	P94	SBI3B	TM19IOA	AN20	ITX0A			
	P95	SBT3B	SCL1B	AN21	IRX0A			
	P96	IRQ0C						
	P97	IRQ1C						
PA0	PA0	SBO7A	SBCS11_4	KEY24	AN0			General Purpose I/O port A
	PA1	SBI7A	SBCS11_3	KEY25	AN1	DAOUT0A		
	PA2	SBT7A	SBCS11_2	KEY26	AN2			
	PA3	SDA5A	SBCS11_1	TM22IOA	KEY27	AN3	DAOUT0B	
	PA4	SCL5A	SBCS11_0	TM21BKA	KEY28	AN4		
	PA5	SBO11	TM21GCPA	KEY29	AN5	DAOUT0C		
	PA6	SBI11	TM21IOA	KEY30	AN6			
	PA7	SBT11	TM20IOA	KEY31	AN7			
PB0	PB0	SBO4C	TM21GCPB					General Purpose I/O port B
	PB1	SBI4C	TM21BKB					
	PB2	SBT4C	TM21IOB					
	PB3	SBO8B						
	PB4	SBI8B						
	PB5	SBT8B						
	PB6							
	PB7							
PC0	PC0	SBO4B	SBO7B	SDA2B				General Purpose I/O port C
	PC1	SBI4B	SBI7B					
	PC2	SBT4B	SBT7B	SCL2B				
	PC3	CTX1B						
	PC4	CRX1B						
	PC5							
	PC6							
PD0	PD0	SBO2B	SBO8A	SDA0B	KEY16	AN22		General Purpose I/O port D
	PD1	SBI2B	SBI8A	KEY17	AN23			
	PD2	SBT2B	SBT8A	SCL0B	KEY18	AN24		
	PD3	SDA3A	IRQ0B	KEY19	AN25	ITX1A		
	PD4	SCL3A	IRQ1B	KEY20	AN26	IRX1A		
	PD5	SDA4A	IRQ2B	KEY21	AN27	CTX1A		
	PD6	SCL4A	TM12IOA	IRQ3B	KEY22	AN28	CRX1A	
	PD7	TM12IOB	IRQ4B	KEY23	AN29			
PE0	PE0	CTX0B						General Purpose I/O port E
	PE1	CRX0B						
	PE2							
	PE3	ITX1B						
	PE4	IRX1B						
	PE5	ITX0B						
	PE6	IRX0B						
	PE7							
PF0	PF0	SBO5B						General Purpose I/O port F
	PF1	SBI5B						
	PF2	SBT5B						
	PF3	SBO6B						
	PF4	SBI6B	SBCS11_7					
	PF5	SBT6B	SBCS11_6					
	PF6	SBCS11_5						



	Pin	Other Function					Description
I/O port	PG0	IRQ2C					General Purpose I/O port G
	PG1	IRQ3C					
	PG2						
	PG3						
	PG4						
	PG5						
	PG6						
	PH0	IRQ4C					General Purpose I/O port H
PH1	IRQ5C						
LED	LED0	P80	A1	TM3IO	KEY8		LED drive pins
	LED1	P81	A0	TM8IOA	KEY9		
	LED2	P82	D15	TM8IOB	KEY10		
	LED3	P83	D14	TM9IOA	KEY11		
	LED4	P84	D13	TM9IOB	KEY12		
	LED5	P85	D12	TM10IOA	KEY13		
	LED6	P86	D11	TM10IOB	KEY14		
	LED7	P87	D10	TM11IOA	KEY15		
OCD	OCD_SDA	P10	TM0IO	AN14			Data I/O pin for on-chip debug function
	OCD_SCL	P11	TM1IO	AN15			Clock input pin for on-chip debug function

*1 Refer to [1.8.2 Unused pins] and [1.8.5 Power Supply Circuit] for detail about note of VDD and function control pins.

*2 CAN-embedded series only.

*3 IEBus-embedded series only.

Table:1.5.7 shows pin functions of 128 pin version.

Table:1.5.7 Pin Functions of 128 pin Version

	Pin	Other Functions				Description
Power supply / Ground *1	VDD50					On-chip regulator power supply Power supply for I/O
	AVDD					Power supply for analog operation.
	VOUT18					Power supply for internal circuit.
	VREFH					Reference power supply pin for the A/D converter.
	VSS					Ground
	AVSS					Ground pin for analog.
Function control *1	OCDMOD					On-chip debug function (OCD) control pin
	ATRST					Auto reset setting pin.
Reset	NRST					Reset signal input pin (Active low)
Clock	OSCI	P45				High-speed oscillation input pin (clkosc = 4 to 20 MHz)
	OSCO	P44				High-speed oscillation output pin
	XI	P46				Low-speed oscillation input pin (clkx = 32.768 kHz)
	XO	P47				Low-speed oscillation output pin
	SYSCLK	P77	TMMIO	IRQ15A		System clock signal output pin
Bus	A20	P30	SBO1A			Address output pins at Memory expansion mode
	A19	P31	SBI1A			
	A18	P32	SBT1A			
	A17	P25	NCTS1/ NRTS1	IRQ5A		
	A16	P50	TM4IOB	KEY32		
	A15	P33	SDA1A	SBO3A		
	A14	P34	SBI3A	TM4IOA		
	A13	P35	SCL1A	SBT3A		
	A12	P51	SBO9	NCTS3/ NRTS3	KEY33	
	A11	P52	SBI9	KEY34		
	A10	P53	SBT9	KEY35		
	A9	P54	NCTS9/ NRTS9	SBO10	KEY36	
	A8	P55	SBI10	KEY37		
	A7	P56	SBT10	KEY38		
	A6	P57	NCTS10/ NRTS10	IRQ8	KEY39	
	A5	P60	TM13IOA	KEY0		
	A4	P61	TM13IOB	KEY1		
	A3	P62	TM14IOA	KEY2		
	A2	P63	TM14IOB	KEY3		
	A1	P80	TM3IO	KEY8	LED0	
	A0	P81	TM8IOA	KEY9	LED1	
	D15	P82	TM8IOB	KEY10	LED2	Data I/O pins at Memory expansion mode
	D14	P83	TM9IOA	KEY11	LED3	
	D13	P84	TM9IOB	KEY12	LED4	
	D12	P85	TM10IOA	KEY13	LED5	
	D11	P86	TM10IOB	KEY14	LED6	
	D10	P87	TM11IOA	KEY15	LED7	
	D9	P64	TM15IOA	KEY4		
	D8	P65	TM15IOB	KEY5		
	D7	P66	TM16IOA	KEY6		
	D6	P67	TM16IOB	KEY7		
	D5	P70	TMMOD0	IRQ9A		
	D4	P71	TMMOD1	IRQ10A		
D3	P72	TMMOD2	IRQ11A			
D2	P73	TMMOD3	IRQ12A			
D1	P74	TMMOD4	IRQ13A			
D0	P75	TMMOD5	IRQ14A			

	Pin	Other Functions					Description
Bus	NCS2	P22	SDA7A	IRQ2A			Chip select signal output pins (Active low)
	NCS1	P21	IRQ1A				
	NRE	P15	SBI0A	AN31	LINRXDA		Read enable signal output pin (Active low)
	NWE1	P14	SBO0A	LINTXDA			Write enable signal output pins (Active low)
	NWE0	P13	TM20IOB	IRQ5B	AN30	NWDOVF2	
	NDK	P20	IRQ0A				Acknowledge signal input pin (Active low)
Watchdog timer 2	NWDOVF2	P13	NWE0	TM20IOB	IRQ5B	AN30	Watchdog timer 2 over flow (Active low)
Interrupt	NMIRQ	P42	SBT4A	SCL2A	IRQ7A		Non-maskable interrupt request signal input pin (Active low)
	IRQ15A	P77	SYSCCLK	TMMIO			External interrupt request signal input pin 15
	IRQ14A	P75	D0	TMMOD5			External interrupt request signal input pin 14
	IRQ13A	P74	D1	TMMOD4			External interrupt request signal input pin 13
	IRQ12A	P73	D2	TMMOD3			External interrupt request signal input pin 12
	IRQ11A	P72	D3	TMMOD2			External interrupt request signal input pin 11
	IRQ10A	P71	D4	TMMOD1			External interrupt request signal input pin 10
	IRQ9A	P70	D5	TMMOD0			External interrupt request signal input pin 9
	IRQ8	P57	A6	NCTS10/ NRTS10	KEY39		External interrupt request signal input pin 8
	IRQ7A	P42	SBT4A	SCL2A	NMIRQ		External interrupt request signal input pin 7 (Pin change is possible)
	IRQ7B	P43	NCTS4/ NRTS4	RTCA			
	IRQ6	P41	SBO4A	SDA2A			External interrupt request signal input pin 6
	IRQ5A	P25	A17	NCTS1/ NRTS1			External interrupt request signal input pin 5 (Pin change is possible)
	IRQ5B	P13	NWE0	TM20IOB	AN30	NWDOVF2	
	IRQ4A	P24					External interrupt request signal input pin 4 (Pin change is possible)
	IRQ4B	PD7	TM12IOB	KEY23	AN29		
	IRQ3A	P23	SCL7A				External interrupt request signal input pin 3 (Pin change is possible)
	IRQ3B	PD6	SCL4A	TM12IOA	KEY22	AN28	CRX1A
	IRQ2A	P22	NCS2	SDA7A			External interrupt request signal input pin 2 (Pin change is possible)
	IRQ2B	PD5	SDA4A	KEY21	AN27	CTX1A	
	IRQ1A	P21	NCS1				External interrupt request signal input pin 1 (Pin change is possible)
	IRQ1B	PD4	SCL3A	KEY20	AN26	IRX1A	
	IRQ0A	P20	NDK				External interrupt request signal input pin 0 (Pin change is possible)
IRQ0B	PD3	SDA3A	KEY19	AN25	ITX1A		
Interrupt	KEY0	P60	A5	TM13IOA			Key input interrupt
	KEY1	P61	A4	TM13IOB			
	KEY2	P62	A3	TM14IOA			
	KEY3	P63	A2	TM14IOB			
	KEY4	P64	D9	TM15IOA			
	KEY5	P65	D8	TM15IOB			
	KEY6	P66	D7	TM16IOA			
	KEY7	P67	D6	TM16IOB			
	KEY8	P80	A1	TM3IO	LED0		
	KEY9	P81	A0	TM8IOA	LED1		
	KEY10	P82	D15	TM8IOB	LED2		
	KEY11	P83	D14	TM9IOA	LED3		
	KEY12	P84	D13	TM9IOB	LED4		
	KEY13	P85	D12	TM10IOA	LED5		
	KEY14	P86	D11	TM10IOB	LED6		
	KEY15	P87	D10	TM11IOA	LED7		
	KEY16	PD0	SBO2B	SBO8A	SDA0B	AN22	
	KEY17	PD1	SBI2B	SBI8A	AN23		
	KEY18	PD2	SBT2B	SBT8A	SCL0B	AN24	
	KEY19	PD3	SDA3A	IRQ0B	AN25	ITX1A	
	KEY20	PD4	SCL3A	IRQ1B	AN26	IRX1A	
	KEY21	PD5	SDA4A	IRQ2B	AN27	CTX1A	
KEY22	PD6	SCL4A	TM12IOA	IRQ3B	AN28	CRX1A	

	Pin	Other Functions					Description		
Interrupt	KEY23	PD7	TM12IOB	IRQ4B	AN29		Key input interrupt		
	KEY24	PA0	SBO7A	SBCS11_4	AN0				
	KEY25	PA1	SBI7A	SBCS11_3	AN1	DAOUT0A			
	KEY26	PA2	SBT7A	SBCS11_2	AN2				
	KEY27	PA3	SDA5A	SBCS11_1	TM22IOA	AN3		DAOUT0B	
	KEY28	PA4	SCL5A	SBCS11_0	TM21BKA	AN4			
	KEY29	PA5	SBO11	TM21GCP A	AN5	DAOUT0C			
	KEY30	PA6	SBI11	TM21IOA	AN6				
	KEY31	PA7	SBT11	TM20IOA	AN7				
	KEY32	P50	A16	TM4IOB					
	KEY33	P51	A12	SBO9	NCTS3/ NRTS3				
	KEY34	P52	A11	SBI9					
	KEY35	P53	A10	SBT9					
	KEY36	P54	A9	NCTS9/ NRTS9	SBO10				
	KEY37	P55	A8	SBI10					
	KEY38	P56	A7	SBT10					
	KEY39	P57	A6	NCTS10/ NRTS10	IRQ8				
	Timer	TM0IO	P10	AN14	OCD_SDA				8-bit Timer 0 to 4 I/O pins
		TM1IO	P11	AN15	OCD_SCL				
TM2IO		P12	TM22IOB						
TM3IO		P80	A1	KEY8	LED0				
TM4IOA		P34	A14	SBI3A					
TM4IOB		P50	A16	KEY32					
TM7IOA		P00	SBO1B	SBO6A	AN8		16-bit Timer 7 I/O pin A, output pin B, C		
TM7OB		P01	SBI1B	SBI6A	AN9	DAOUT1A			
TM7OC		P02	SBT1B	SBT6A	NCTS2/ NRTS2	AN10			
TM8IOA		P81	A0	KEY9	LED1		16-bit Timer 8 to 19 I/O pins A, B		
TM8IOB		P82	D15	KEY10	LED2				
TM9IOA		P83	D14	KEY11	LED3				
TM9IOB		P84	D13	KEY12	LED4				
TM10IOA		P85	D12	KEY13	LED5				
TM10IOB		P86	D11	KEY14	LED6				
TM11IOA		P87	D10	KEY15	LED7				
TM11IOB		P40	SBI4A						
TM12IOA		PD6	SCL4A	IRQ3B	KEY22	AN28		CRX1A	
TM12IOB		PD7	IRQ4B	KEY23	AN29				
TM13IOA		P60	A5	KEY0					
TM13IOB		P61	A4	KEY1					
TM14IOA		P62	A3	KEY2					
TM14IOB		P63	A2	KEY3					
TM15IOA		P64	D9	KEY4					
TM15IOB		P65	D8	KEY5					
TM16IOA		P66	D7	KEY6					
TM16IOB		P67	D6	KEY7					
TM17IOA		P90	SBO0B	SDA6A	AN16	CTX0A	LINTXDB		
TM18IOA		P92	SBT0B	SCL6A	AN18				
TM19IOA		P94	SBI3B	AN20	ITX0A				
TM20IOA		PA7	SBT11	KEY31	AN7		8-bit Timer 20 to 22 I/O pins (Pin change is possible)		
TM20IOB		P13	NWE0	IRQ5B	AN30	NWDOVF2			
TM21IOA		PA6	SBI11	KEY30	AN6				
TM21IOB		PB2	SBT4C						
TM22IOA		PA3	SDA5A	SBCS11_1	KEY27	AN3		DAOUT0B	
TM22IOB		P12	TM2IO						

	Pin	Other Functions						Description
Timer	TM21BKA	PA4	SCL5A	SBCS11_0	KEY28	AN4	8-bit Timer 21 I/O pins (Pin change is possible)	
	TM21BKB	PB1	SBI4C					
	TM21GCPA	PA5	SBO11	KEY29	AN5	DAOUT0C		
	TM21GCPB	PB0	SBO4C					
	TMMOD0	P70	D5	IRQ9A			Motor control 16-bit Timer I/O pins	
	TMMOD1	P71	D4	IRQ10A				
	TMMOD2	P72	D3	IRQ11A				
	TMMOD3	P73	D2	IRQ12A				
	TMMOD4	P74	D1	IRQ13A				
	TMMOD5	P75	D0	IRQ14A				
TMMIO	P77	SYSCCLK	IRQ15A					
Serial	SBT0A	P16					Serial clock I/O pins (Pin change is possible) - Clock synchronous/UART	
	SBT0B	P92	SCL6A	TM18IOA	AN18			
	SBT1A	P32	A18					
	SBT1B	P02	SBT6A	NCTS2/ NRTS2	TM7OC	AN10		
	SBT2A	P05	SBT5A	SCL0A	AN13	DAOUT1C		
	SBT2B	PD2	SBT8A	SCL0B	KEY18	AN24		
	SBT3A	P35	A13	SCL1A				
	SBT3B	P95	SCL1B	AN21	IRX0A			
	SBT4A	P42	SCL2A	IRQ7A	NMIRQ			
	SBT4B	PC2	SBT7B	SCL2B				
	SBT4C	PB2	TM21IOB					
	SBT5A	P05	SCL0A	SBT2A	AN13	DAOUT1C		
	SBT5B	PF2						
	SBT6A	P02	SBT1B	NCTS2/ NRTS2	TM7OC	AN10		
	SBT6B	PF5	SBCS11_6					
	SBT7A	PA2	SBCS11_2	KEY26	AN2			
	SBT7B	PC2	SBT4B	SCL2B				
	SBT8A	PD2	SBT2B	SCL0B	KEY18	AN24	Serial clock I/O pins (Pin change is possible) - Clock synchronous/UART	
	SBT8B	PB5						
	SBT9	P53	A10	KEY35				
	SBT10	P56	A7	KEY38				
	SBT11	PA7	TM20IOA	KEY31	AN7			
	SBO0A	P14	NWE1	LINTXDA				
	SBO0B	P90	SDA6A	TM17IOA	AN16	CTX0A		LINTXDB
	SBO1A	P30	A20					
	SBO1B	P00	SBO6A	TM7IOA	AN8			
	SBO2A	P03	SBO5A	SDA0A	AN11	DAOUT1B		
	SBO2B	PD0	SBO8A	SDA0B	KEY16	AN22		
	SBO3A	P33	A15	SDA1A				
	SBO3B	P93	SDA1B	AN19				
	SBO4A	P41	SDA2A	IRQ6				
	SBO4B	PC0	SBO7B	SDA2B				
	SBO4C	PB0	TM21GCP B					
	SBO5A	P03	SDA0A	SBO2A	AN11	DAOUT1B		
SBO5B	PF0							
SBO6A	P00	SBO1B	TM7IOA	AN8				
SBO6B	PF3							
SBO7A	PA0	SBCS11_4	KEY24	AN0				
SBO7B	PC0	SBO4B	SDA2B					
SBO8A	PD0	SBO2B	SDA0B	KEY16	AN22			
SBO8B	PB3							
SBO9	P51	A12	NCTS3/ NRTS3	KEY33				

	Pin	Other Functions						Description	
Serial	SBO10	P54	A9	NCTS9/ NRTS9	KEY36			Serial data output pins (Pin change is possible) - Clock synchronous/UART	
	SBO11	PA5	TM21GCP A	KEY29	AN5	DAOUT0C			
Serial	SBI0A	P15	NRE	AN31	LINRXDA			Serial data input pins (Pin change is possible) - Clock synchronous/UART	
	SBI0B	P91	AN17	CRX0A	LINRXDB				
	SBI1A	P31	A19						
	SBI1B	P01	SBI6A	TM7OB	AN9	DAOUT1A			
	SBI2A	P04	SBI5A	AN12					
	SBI2B	PD1	SBI8A	KEY17	AN23				
	SBI3A	P34	A14	TM4IOA					
	SBI3B	P94	TM19IOA	AN20	ITX0A				
	SBI4A	P40	TM11IOB						
	SBI4B	PC1	SBI7B						
	SBI4C	PB1	TM21BKB						
	SBI5A	P04	SBI2A	AN12					
	SBI5B	PF1							
	SBI6A	P01	SBI1B	TM7OB	AN9	DAOUT1A			
	SBI6B	PF4	SBSC11_7						
	SBI7A	PA1	SBSC11_3	KEY25	AN1	DAOUT0A			
	SBI7B	PC1	SBI4B						
	SBI8A	PD1	SBI2B	KEY17	AN23				
	SBI8B	PB4							
	SBI9	P52	A11	KEY34					
	SBI10	P55	A8	KEY37					
	SBI11	PA6	TM21IOA	KEY30	AN6				
	SBSC11_7	PF4	SBI6B						4-wire serial chip select pins - Clock synchronous
	SBSC11_5	PF6							
	SBSC11_4	PA0	SBO7A	KEY24	AN0				
	SBSC11_3	PA1	SBI7A	KEY25	AN1	DAOUT0A			
SBSC11_2	PA2	SBT7A	KEY26	AN2					
SBSC11_1	PA3	SDA5A	TM22IOA	KEY27	AN3	DAOUT0B			
SBSC11_0	PA4	SCL5A	TM21BKA	KEY28	AN4		CTS/RTS I/O pins		
NCTS1/ NRTS1	P25	A17	IRQ5A						
NCTS2/ NRTS2	P02	SBT1B	SBT6A	TM7OC	AN10				
NCTS3/ NRTS3	P51	A12	SBO9	KEY33					
NCTS4/ NRTS4	P43	IRQ7B	RTCA						
NCTS9/ NRTS9	P54	A9	SBO10	KEY36					
NCTS10/ NRTS10	P57	A6	IRQ8	KEY39					
IIC	SCL0A	P05	SBT5A	SBT2A	AN13	DAOUT1C	IIC clock I/O pins		
	SCL0B	PD2	SBT2B	SBT8A	KEY18	AN24			
	SCL1A	P35	A13	SBT3A					
	SCL1B	P95	SBT3B	AN21	IRX0A				
	SCL2A	P42	SBT4A	IRQ7A	NMIRQ				
	SCL2B	PC2	SBT4B	SBT7B					
	SCL3A	PD4	IRQ1B	KEY20	AN26	IRX1A			
	SCL4A	PD6	TM12IOA	IRQ3B	KEY22	AN28		CRX1A	
	SCL5A	PA4	SBSC11_0	TM21BKA	KEY28	AN4			
	SCL6A	P92	SBT0B	TM18IOA	AN18				
SCL7A	P23	IRQ3A							

	Pin	Other Functions						Description
IIC	SDA0A	P03	SBO5A	SBO2A	AN11	DAOUT1B		IIC data I/O pins (Pin change is possible)
	SDA0B	PD0	SBO2B	SBO8A	KEY16	AN22		
	SDA1A	P33	A15	SBO3A				
	SDA1B	P93	SBO3B	AN19				
	SDA2A	P41	SBO4A	IRQ6				
	SDA2B	PC0	SBO4B	SBO7B				
	SDA3A	PD3	IRQ0B	KEY19	AN25	ITX1A		
	SDA4A	PD5	IRQ2B	KEY21	AN27	CTX1A		
	SDA5A	PA3	SBCS11_1	TM22IOA	KEY27	AN3	DAOUT0B	
	SDA6A	P90	SBO0B	TM17IOA	AN16	CTX0A	LINTXDB	
SDA7A	P22	NCS2	IRQ2A					
LIN	LINTXDA	P14	SBO0A	NWE1				LIN data transmission pins (Pin change is possible)
	LINTXDB	P90	SBO0B	SDA6A	TM17IOA	AN16	(CTX0A) *2	
	LINRXDA	P15	SBI0A	NRE	AN31			LIN data reception pins (Pin change is possible)
	LINRXDB	P91	SBI0B	AN17	(CRX0A) *2			
CAN *2	CTX0A	P90	SBO0B	SDA6A	TM17IOA	AN16	LINTXDB	CAN data transmission pin (Pin change is possible)
	CTX0B	PE0						
	CTX1A	PD5	SDA4A	IRQ2B	KEY21	AN27		
	CTX1B	PC3						CAN data reception pin (Pin change is possible)
	CRX0A	P91	SBI0B	AN17	LINRXDB			
	CRX0B	PE1						
	CRX1A	PD6	SCL4A	TM12IOA	IRQ3B	KEY22	AN28	
CRX1B	PC4							
IEBus *3	ITX0A	P94	SBI3B	TM19IOA	AN20			IEBus data transmission pin (Pin change is possible)
	ITX0B	PE5						
	ITX1A	PD3	SDA3A	IRQ0B	KEY19	AN25		
	ITX1B	PE3						
IEBus *3	IRX0A	P95	SBT3B	SCL1B	AN21			IEBus data reception pin (Pin change is possible)
	IRX0B	PE6						
	IRX1A	PD4	SCL3A	IRQ1B	KEY20	AN26		
	IRX1B	PE4						
A/D converter	AN0	PA0	SBO7A	SBCS11_4	KEY24			Analog input pins
	AN1	PA1	SBI7A	SBCS11_3	KEY25	DAOUT0A		
	AN2	PA2	SBT7A	SBCS11_2	KEY26			
	AN3	PA3	SDA5A	SBCS11_1	TM22IOA	KEY27	DAOUT0B	
	AN4	PA4	SCL5A	SBCS11_0	TM21BKA	KEY28		
	AN5	PA5	SBO11	TM21GCP A	KEY29	DAOUT0C		
	AN6	PA6	SBI11	TM21IOA	KEY30			
	AN7	PA7	SBT11	TM20IOA	KEY31			
	AN8	P00	SBO1B	SBO6A	TM7IOA			
	AN9	P01	SBI1B	SBI6A	TM7OB	DAOUT1A		
	AN10	P02	SBT1B	SBT6A	NCTS2/ NRTS2	TM7OC		
	AN11	P03	SBO5A	SDA0A	SBO2A	DAOUT1B		
	AN12	P04	SBI5A	SBI2A				
	AN13	P05	SBT5A	SCL0A	SBT2A	DAOUT1C		
	AN14	P10	TM0IO	OCD_SDA				
	AN15	P11	TM1IO	OCD_SCL				
	AN16	P90	SBO0B	SDA6A	TM17IOA	CTX0A	LINTXDB	
	AN17	P91	SBI0B	CRX0A	LINRXDB			
	AN18	P92	SBT0B	SCL6A	TM18IOA			
	AN19	P93	SBO3B	SDA1B				
	AN20	P94	SBI3B	TM19IOA	ITX0A			
	AN21	P95	SBT3B	SCL1B	IRX0A			
AN22	PD0	SBO2B	SBO8A	SDA0B	KEY16			

	Pin	Other Functions						Description	
A/D converter	AN23	PD1	SBI2B	SBI8A	KEY17			Analog input pins	
	AN24	PD2	SBT2B	SBT8A	SCL0B	KEY18			
	AN25	PD3	SDA3A	IRQ0B	KEY19	ITX1A			
	AN26	PD4	SCL3A	IRQ1B	KEY20	IRX1A			
	AN27	PD5	SDA4A	IRQ2B	KEY21	CTX1A			
	AN28	PD6	SCL4A	TM12IOA	IRQ3B	KEY22	CRX1A		
	AN29	PD7	TM12IOB	IRQ4B	KEY23				
	AN30	P13	NWE0	TM20IOB	IRQ5B	NWDOVF2			
	AN31	P15	NRE	SBI0A	LINRXDA				
D/A converter	DAOUT0A	PA1	SBI7A	SBCS11_3	KEY25	AN1		Analog output pins	
	DAOUT0B	PA3	SDA5A	SBCS11_1	TM22IOA	KEY27	AN3		
	DAOUT0C	PA5	SBO11	TM21GCP A	KEY29	AN5			
	DAOUT1A	P01	SBI1B	SBI6A	TM7OB	AN9			
	DAOUT1B	P03	SBO5A	SDA0A	SBO2A	AN11			
	DAOUT1C	P05	SBT5A	SCL0A	SBT2A	AN13			
RTC	RTCA	P43	NCTS4/ NRTS4	IRQ7B				Real time clock output pins	
I/O port	P00	SBO1B	SBO6A	TM7IOA	AN8			General Purpose I/O port 0	
	P01	SBI1B	SBI6A	TM7OB	AN9	DAOUT1A			
	P02	SBT1B	SBT6A	NCTS2/ NRTS2	TM7OC	AN10			
	P03	SBO5A	SDA0A	SBO2A	AN11	DAOUT1B			
	P04	SBI5A	SBI2A	AN12					
	P05	SBT5A	SCL0A	SBT2A	AN13	DAOUT1C			
	P06								
	P07								
I/O port	P10	TM0IO	AN14	OCD_SDA				General Purpose I/O port 1	
	P11	TM1IO	AN15	OCD_SCL					
	P12	TM2IO	TM22IOB						
	P13	NWE0	TM20IOB	IRQ5B	AN30	NWDOVF2			
	P14	NWE1	SBO0A	LINTXDA					
	P15	NRE	SBI0A	AN31	LINRXDA				
	P16	SBT0A							
	P20	NDK	IRQ0A						General Purpose I/O port 2
	P21	NCS1	IRQ1A						
	P22	NCS2	SDA7A	IRQ2A					
P23	SCL7A	IRQ3A							
P24	IRQ4A								
P25	A17	NCTS1/ NRTS1	IRQ5A						
I/O port	P30	A20	SBO1A					General Purpose I/O port 3	
	P31	A19	SBI1A						
	P32	A18	SBT1A						
	P33	A15	SDA1A	SBO3A					
	P34	A14	SBI3A	TM4IOA					
	P35	A13	SCL1A	SBT3A					
I/O port	P40	SBI4A	TM11IOB					General Purpose I/O port 4	
	P41	SBO4A	SDA2A	IRQ6					
	P42	SBT4A	SCL2A	IRQ7A	NMIRQ				
	P43	NCTS4/ NRTS4	IRQ7B	RTCA					
	P44	OSCO							
	P45	OSCI							
	P46	XI							
	P47	XO							



I/O port	Pin	Other Functions						Description
P50-P57	P50	A16	TM4IOB	KEY32				General Purpose I/O port 5
	P51	A12	SBO9	NCTS3/ NRTS3	KEY33			
	P52	A11	SBI9	KEY34				
	P53	A10	SBT9	KEY35				
	P54	A9	NCTS9/ NRTS9	SBO10	KEY36			
	P55	A8	SBI10	KEY37				
	P56	A7	SBT10	KEY38				
	P57	A6	NCTS10/ NRTS10	IRQ8	KEY39			
P60-P67	P60	A5	TM13IOA	KEY0				General Purpose I/O port 6
	P61	A4	TM13IOB	KEY1				
	P62	A3	TM14IOA	KEY2				
	P63	A2	TM14IOB	KEY3				
	P64	D9	TM15IOA	KEY4				
	P65	D8	TM15IOB	KEY5				
	P66	D7	TM16IOA	KEY6				
	P67	D6	TM16IOB	KEY7				
P70-P77	P70	D5	TMMOD0	IRQ9A				General Purpose I/O port 7
	P71	D4	TMMOD1	IRQ10A				
	P72	D3	TMMOD2	IRQ11A				
	P73	D2	TMMOD3	IRQ12A				
	P74	D1	TMMOD4	IRQ13A				
	P75	D0	TMMOD5	IRQ14A				
	P77	SYCLK	TMMIO	IRQ15A				
P80-P87	P80	A1	TM3IO	KEY8	LED0			General Purpose I/O port 8
	P81	A0	TM8IOA	KEY9	LED1			
	P82	D15	TM8IOB	KEY10	LED2			
	P83	D14	TM9IOA	KEY11	LED3			
	P84	D13	TM9IOB	KEY12	LED4			
	P85	D12	TM10IOA	KEY13	LED5			
	P86	D11	TM10IOB	KEY14	LED6			
	P87	D10	TM11IOA	KEY15	LED7			
P90-P95	P90	SBO0B	SDA6A	TM17IOA	AN16	CTX0A	LINTXDB	General Purpose I/O port 9
	P91	SBI0B	AN17	CRX0A	LINRXDB			
	P92	SBT0B	SCL6A	TM18IOA	AN18			
	P93	SBO3B	SDA1B	AN19				
	P94	SBI3B	TM19IOA	AN20	ITX0A			
	P95	SBT3B	SCL1B	AN21	IRX0A			
PA0-PA7	PA0	SBO7A	SBCS11_4	KEY24	AN0			General Purpose I/O port A
	PA1	SBI7A	SBCS11_3	KEY25	AN1	DAOUT0A		
	PA2	SBT7A	SBCS11_2	KEY26	AN2			
	PA3	SDA5A	SBCS11_1	TM22IOA	KEY27	AN3	DAOUT0B	
	PA4	SCL5A	SBCS11_0	TM21BKA	KEY28	AN4		
	PA5	SBO11	TM21GCP A	KEY29	AN5	DAOUT0C		
	PA6	SBI11	TM21IOA	KEY30	AN6			
	PA7	SBT11	TM20IOA	KEY31	AN7			
PB0-PB5	PB0	SBO4C	TM21GCP B					General Purpose I/O port B
	PB1	SBI4C	TM21BKB					
	PB2	SBT4C	TM21IOB					
	PB3	SBO8B						
	PB4	SBI8B						
	PB5	SBT8B						



	Pin	Other Functions						Description
I/O port	PC0	SBO4B	SBO7B	SDA2B				General Purpose I/O port C
	PC1	SBI4B	SBI7B					
	PC2	SBT4B	SBT7B	SCL2B				
	PC3	CTX1B						
	PC4	CRX1B						
	PC5							
	PC6							
	PD0	SBO2B	SBO8A	SDA0B	KEY16	AN22		General Purpose I/O port D
	PD1	SBI2B	SBI8A	KEY17	AN23			
	PD2	SBT2B	SBT8A	SCL0B	KEY18	AN24		
	PD3	SDA3A	IRQ0B	KEY19	AN25	ITX1A		
	PD4	SCL3A	IRQ1B	KEY20	AN26	IRX1A		
	PD5	SDA4A	IRQ2B	KEY21	AN27	CTX1A		
	PD6	SCL4A	TM12IOA	IRQ3B	KEY22	AN28	CRX1A	
	PD7	TM12IOB	IRQ4B	KEY23	AN29			
	PE0	CTX0B						General Purpose I/O port E
	PE1	CRX0B						
	PE2							
	PE3	ITX1B						
	PE4	IRX1B						
PE5	ITX0B							
PE6	IRX0B							
PF0	SBO5B						General Purpose I/O port F	
PF1	SBI5B							
PF2	SBT5B							
PF3	SBO6B							
PF4	SBI6B	SBCS11_7						
PF5	SBT6B	SBCS11_6						
PF6	SBCS11_5							
LED	LED0	P80	A1	TM3IO	KEY8			LED drive pins
	LED1	P81	A0	TM8IOA	KEY9			
	LED2	P82	D15	TM8IOB	KEY10			
	LED3	P83	D14	TM9IOA	KEY11			
	LED4	P84	D13	TM9IOB	KEY12			
	LED5	P85	D12	TM10IOA	KEY13			
	LED6	P86	D11	TM10IOB	KEY14			
	LED7	P87	D10	TM11IOA	KEY15			
OCD	OCD_SDA	P10	TM0IO	AN14				Data I/O pin for on-chip debug function
	OCD_SCL	P11	TM1IO	AN15				Clock input pin for on-chip debug function

*1 Refer to [1.8.2 Unused pins] and [1.8.5 Power Supply Circuit] for detail about note of VDD and function control pins.

*2 CAN-embedded series only.

*3 IEBus-embedded series only.

Table:1.5.8 shows pin functions of 100 pin version.

Table:1.5.8 Pin Functions of 100 pin Version

	Pin	Other Function				Description	
Power supply / Ground *1	VDD50					On-chip regulator power supply Power supply for I/O	
	AVDD					Power supply for analog operation.	
	VOUT18					Power supply for internal circuit.	
	VREFH					Reference power supply pin for the A/D converter.	
	VSS					Ground	
	AVSS					Ground pin for analog.	
Function control *1	OCDMOD					On-chip debug function (OCD) control pin	
	ATRST					Auto reset setting pin.	
Reset	NRST					Reset signal input pin (Active low)	
Clock	OSCI	P45				High-speed oscillation input pin (clkosc = 4 to 20 MHz)	
	OSCO	P44				High-speed oscillation output pin	
	XI	P46				Low-speed oscillation input pin (clkx = 32.768 kHz)	
	XO	P47				Low-speed oscillation output pin	
	SYSCCLK	P77	TMMIO	IRQ15A		System clock signal output pin	
Bus	A20	P30	SBO1A			Address output pins at Memory expansion mode	
	A19	P31	SBI1A				
	A18	P32	SBT1A				
	A17	P25	NCTS1/ NRTS1	IRQ5A			
	A16	P50	TM4IOB	KEY32			
	A15	P33	SDA1A	SBO3A			
	A14	P34	SBI3A	TM4IOA			
	A13	P35	SCL1A	SBT3A			
	A12	P51	SBO9	NCTS3/ NRTS3	KEY33		
	A11	P52	SBI9	KEY34			
	A10	P53	SBT9	KEY35			
	A9	P54	NCTS9/ NRTS9	SBO10	KEY36		
	A8	P55	SBI10	KEY37			
	A7	P56	SBT10	KEY38			
	A6	P57	NCTS10/ NRTS10	IRQ8	KEY39		
	A5	P60	TM13IOA	KEY0			
	A4	P61	TM13IOB	KEY1			
	A3	P62	TM14IOA	KEY2			
	A2	P63	TM14IOB	KEY3			
	A1	P80	TM3IO	KEY8	LED0		
A0	P81	TM8IOA	KEY9	LED1			
Bus	D15	P82	TM8IOB	KEY10	LED2	Data I/O pins at Memory expansion mode	
	D14	P83	TM9IOA	KEY11	LED3		
	D13	P84	TM9IOB	KEY12	LED4		
	D12	P85	TM10IOA	KEY13	LED5		
	D11	P86	TM10IOB	KEY14	LED6		
	D10	P87	TM11IOA	KEY15	LED7		
	D9	P64	TM15IOA	KEY4			
	D8	P65	TM15IOB	KEY5			
	D7	P66	TM16IOA	KEY6			
	D6	P67	TM16IOB	KEY7			
	D5	P70	TMMOD0	IRQ9A			
	D4	P71	TMMOD1	IRQ10A			
	D3	P72	TMMOD2	IRQ11A			
	D2	P73	TMMOD3	IRQ12A			

	Pin	Other Function						Description
Bus	D1	P74	TMMOD4	IRQ13A				Data I/O pins at Memory expansion mode
	D0	P75	TMMOD5	IRQ14A				
	NCS2	P22	SDA7A	IRQ2A				Chip select signal output pins (Active low)
	NCS1	P21	IRQ1A					
	NRE	P15	SBI0A	AN31	LINRXDA			Read enable signal output pin (Active low)
	NWE1	P14	SBO0A	LINTXDA				Write enable signal output pins (Active low)
	NWE0	P13	TM20IOB	IRQ5B	AN30	NWDOVF2		
	NDK	P20	IRQ0A					Acknowledge signal input pin (Active low)
Watchdog timer 2	NWDOVF2	P13	NWE0	TM20IOB	IRQ5B	AN30		Watchdog timer 2 over flow (Active low)
Interrupt	NMIRQ	P42	SBT4A	SCL2A	IRQ7A			Non-maskable interrupt request signal input pin (Active low)
	IRQ15A	P77	SYSCLK	TMMIO				External interrupt request signal input pin 15
	IRQ14A	P75	D0	TMMOD5				External interrupt request signal input pin 14
	IRQ13A	P74	D1	TMMOD4				External interrupt request signal input pin 13
	IRQ12A	P73	D2	TMMOD3				External interrupt request signal input pin 12
	IRQ11A	P72	D3	TMMOD2				External interrupt request signal input pin 11
	IRQ10A	P71	D4	TMMOD1				External interrupt request signal input pin 10
	IRQ9A	P70	D5	TMMOD0				External interrupt request signal input pin 9
	IRQ8	P57	A6	NCTS10/ NRTS10	KEY39			External interrupt request signal input pin 8
	IRQ7A	P42	SBT4A	SCL2A	NMIRQ			External interrupt request signal input pin 7 (Pin change is possible)
	IRQ7B	P43	NCTS4/ NRTS4	RTCA				
	IRQ6	P41	SBO4A	SDA2A				External interrupt request signal input pin 6
	IRQ5A	P25	A17	NCTS1/ NRTS1				External interrupt request signal input pin 5 (Pin change is possible)
	IRQ5B	P13	NWE0	TM20IOB	AN30	NWDOVF2		
	IRQ4A	P24						External interrupt request signal input pin 4 (Pin change is possible)
	IRQ4B	PD7	TM12IOB	KEY23	AN29			
	IRQ3A	P23	SCL7A					External interrupt request signal input pin 3 (Pin change is possible)
	IRQ3B	PD6	SCL4A	TM12IOA	KEY22	AN28	CRX1A	
	IRQ2A	P22	NCS2	SDA7A				External interrupt request signal input pin 2 (Pin change is possible)
	IRQ2B	PD5	SDA4A	KEY21	AN27	CTX1A		
	IRQ1A	P21	NCS1					External interrupt request signal input pin 1 (Pin change is possible)
IRQ1B	PD4	SCL3A	KEY20	AN26	IRX1A			
IRQ0A	P20	NDK					External interrupt request signal input pin 0 (Pin change is possible)	
IRQ0B	PD3	SDA3A	KEY19	AN25	ITX1A			
Interrupt	KEY0	P60	A5	TM13IOA				Key input interrupt
	KEY1	P61	A4	TM13IOB				
	KEY2	P62	A3	TM14IOA				
	KEY3	P63	A2	TM14IOB				
	KEY4	P64	D9	TM15IOA				
	KEY5	P65	D8	TM15IOB				
	KEY6	P66	D7	TM16IOA				
	KEY7	P67	D6	TM16IOB				
	KEY8	P80	A1	TM3IO	LED0			
	KEY9	P81	A0	TM8IOA	LED1			
	KEY10	P82	D15	TM8IOB	LED2			
	KEY11	P83	D14	TM9IOA	LED3			
	KEY12	P84	D13	TM9IOB	LED4			
	KEY13	P85	D12	TM10IOA	LED5			
	KEY14	P86	D11	TM10IOB	LED6			
	KEY15	P87	D10	TM11IOA	LED7			
	KEY16	PD0	SBO2B	SBO8A	SDA0B	AN22		
	KEY17	PD1	SBI2B	SBI8A	AN23			
KEY18	PD2	SBT2B	SBT8A	SCL0B	AN24			

	Pin	Other Function						Description
Interrupt	KEY19	PD3	SDA3A	IRQ0B	AN25	ITX1A		Key input interrupt
	KEY20	PD4	SCL3A	IRQ1B	AN26	IRX1A		
	KEY21	PD5	SDA4A	IRQ2B	AN27	CTX1A		
	KEY22	PD6	SCL4A	TM12IOA	IRQ3B	AN28	CRX1A	
	KEY23	PD7	TM12IOB	IRQ4B	AN29			
	KEY24	PA0	SBO7A	SBCS11_4	AN0			
	KEY25	PA1	SBI7A	SBCS11_3	AN1	DAOUT0A		
	KEY26	PA2	SBT7A	SBCS11_2	AN2			
	KEY27	PA3	SDA5A	SBCS11_1	TM22IOA	AN3	DAOUT0B	
	KEY28	PA4	SCL5A	SBCS11_0	TM21BKA	AN4		
	KEY29	PA5	SBO11	TM21GCP A	AN5	DAOUT0C		
	KEY30	PA6	SBI11	TM21IOA	AN6			
	KEY31	PA7	SBT11	TM20IOA	AN7			
	KEY32	P50	A16	TM4IOB				
	KEY33	P51	A12	SBO9	NCTS3/ NRTS3			
	KEY34	P52	A11	SBI9				
	KEY35	P53	A10	SBT9				
	KEY36	P54	A9	NCTS9/ NRTS9	SBO10			
	KEY37	P55	A8	SBI10				
	KEY38	P56	A7	SBT10				
KEY39	P57	A6	NCTS10/ NRTS10	IRQ8				
Timer	TM0IO	P10	AN14	OCD_SDA				8-bit Timer 0 to 4 I/O pins
	TM1IO	P11	AN15	OCD_SCL				
	TM2IO	P12	TM22IOB					
	TM3IO	P80	A1	KEY8	LED0			
	TM4IOA	P34	A14	SBI3A				16-bit Timer 7 I/O pin A, output pin B, C
	TM4IOB	P50	A16	KEY32				
	TM7IOA	P00	SBO1B	SBO6A	AN8			
	TM7OB	P01	SBI1B	SBI6A	AN9	DAOUT1A		
	TM7OC	P02	SBT1B	SBT6A	NCTS2/ NRTS2	AN10		
	TM8IOA	P81	A0	KEY9	LED1			16-bit Timer 8 to 19 I/O pins A, B
	TM8IOB	P82	D15	KEY10	LED2			
	TM9IOA	P83	D14	KEY11	LED3			
	TM9IOB	P84	D13	KEY12	LED4			
	TM10IOA	P85	D12	KEY13	LED5			
	TM10IOB	P86	D11	KEY14	LED6			
	TM11IOA	P87	D10	KEY15	LED7			
	TM11IOB	P40	SBI4A					
	TM12IOA	PD6	SCL4A	IRQ3B	KEY22	AN28	CRX1A	
	TM12IOB	PD7	IRQ4B	KEY23	AN29			
	TM13IOA	P60	A5	KEY0				
TM13IOB	P61	A4	KEY1					
TM14IOA	P62	A3	KEY2					
TM14IOB	P63	A2	KEY3					
TM15IOA	P64	D9	KEY4					
TM15IOB	P65	D8	KEY5					
TM16IOA	P66	D7	KEY6					
TM16IOB	P67	D6	KEY7					
TM17IOA	P90	SBO0B	SDA6A	AN16	CTX0A	LINTXDB		
TM18IOA	P92	SBT0B	SCL6A	AN18				
TM19IOA	P94	SBI3B	AN20	ITX0A				

	Pin	Other Function					Description	
Timer	TM20IOA	PA7	SBT11	KEY31	AN7		8-bit Timer 20 to 22 I/O pins (Pin change is possible)	
	TM20IOB	P13	NWE0	IRQ5B	AN30	NWDOVF2		
	TM21IOA	PA6	SBI11	KEY30	AN6			
	TM22IOA	PA3	SDA5A	SBCS11_1	KEY27	AN3		DAOUT0B
	TM22IOB	P12	TM2IO					
	TM21BKA	PA4	SCL5A	SBCS11_0	KEY28	AN4	8-bit Timer 21 I/O pins (Pin change is possible)	
	TM21GCPA	PA5	SBO11	KEY29	AN5	DAOUT0C		
	TMMOD0	P70	D5	IRQ9A			Motor control 16-bit Timer I/O pins	
	TMMOD1	P71	D4	IRQ10A				
	TMMOD2	P72	D3	IRQ11A				
	TMMOD3	P73	D2	IRQ12A				
	TMMOD4	P74	D1	IRQ13A				
	TMMOD5	P75	D0	IRQ14A				
TMMIO	P77	SYSCLK	IRQ15A					
Serial	SBT0A	P16					Serial clock I/O pins (Pin change is possible) - Clock synchronous/UART	
	SBT0B	P92	SCL6A	TM18IOA	AN18			
	SBT1A	P32	A18					
	SBT1B	P02	SBT6A	NCTS2/ NRTS2	TM7OC	AN10		
	SBT2A	P05	SBT5A	SCL0A	AN13	DAOUT1C		
	SBT2B	PD2	SBT8A	SCL0B	KEY18	AN24		
	SBT3A	P35	A13	SCL1A				
	SBT3B	P95	SCL1B	AN21	IRX0A			
	SBT4A	P42	SCL2A	IRQ7A	NMIRQ			
	SBT5A	P05	SCL0A	SBT2A	AN13	DAOUT1C		
	SBT6A	P02	SBT1B	NCTS2/ NRTS2	TM7OC	AN10		
	SBT7A	PA2	SBCS11_2	KEY26	AN2			
	SBT8A	PD2	SBT2B	SCL0B	KEY18	AN24		
	SBT9	P53	A10	KEY35				
	SBT10	P56	A7	KEY38				
	SBT11	PA7	TM20IOA	KEY31	AN7			
	SBO0A	P14	NWE1	LINTXDA				
	SBO0B	P90	SDA6A	TM17IOA	AN16	CTX0A	LINTXDB	
	SBO1A	P30	A20					
	SBO1B	P00	SBO6A	TM7IOA	AN8			
	SBO2A	P03	SBO5A	SDA0A	AN11	DAOUT1B		
	SBO2B	PD0	SBO8A	SDA0B	KEY16	AN22		
	SBO3A	P33	A15	SDA1A				
	SBO3B	P93	SDA1B	AN19				
	SBO4A	P41	SDA2A	IRQ6				
	SBO5A	P03	SDA0A	SBO2A	AN11	DAOUT1B		
	SBO6A	P00	SBO1B	TM7IOA	AN8			
	SBO7A	PA0	SBCS11_4	KEY24	AN0			
	SBO8A	PD0	SBO2B	SDA0B	KEY16	AN22		
	SBO9	P51	A12	NCTS3/ NRTS3	KEY33			
SBO10	P54	A9	NCTS9/ NRTS9	KEY36				
SBO11	PA5	TM21GCP A	KEY29	AN5	DAOUT0C			
						Serial clock I/O pins (Pin change is possible) - Clock synchronous/UART		

	Pin	Other Function					Description	
Serial	SBI0A	P15	NRE	AN31	LINRXDA		Serial data output pins (Pin change is possible) - Clock synchronous/UART	
	SBI0B	P91	AN17	CRX0A	LINRXDB			
	SBI1A	P31	A19					
	SBI1B	P01	SBI6A	TM7OB	AN9	DAOUT1A		
	SBI2A	P04	SBI5A	AN12				
	SBI2B	PD1	SBI8A	KEY17	AN23			
	SBI3A	P34	A14	TM4IOA				
	SBI3B	P94	TM19IOA	AN20	ITX0A			
	SBI4A	P40	TM11IOB					
	SBI5A	P04	SBI2A	AN12				
	SBI6A	P01	SBI1B	TM7OB	AN9	DAOUT1A		
	SBI7A	PA1	SBCS11_3	KEY25	AN1	DAOUT0A		
	SBI8A	PD1	SBI2B	KEY17	AN23			
	SBI9	P52	A11	KEY34				
	SBI10	P55	A8	KEY37				
	SBI11	PA6	TM21IOA	KEY30	AN6			
	Serial	SBCS11_4	PA0	SBO7A	KEY24	AN0		
SBCS11_3		PA1	SBI7A	KEY25	AN1	DAOUT0A		
SBCS11_2		PA2	SBT7A	KEY26	AN2			
SBCS11_1		PA3	SDA5A	TM22IOA	KEY27	AN3	DAOUT0B	
SBCS11_0		PA4	SCL5A	TM21BKA	KEY28	AN4		
Serial	NCTS1/ NRTS1	P25	A17	IRQ5A			CTS/RTS I/O pins	
	NCTS2/ NRTS2	P02	SBT1B	SBT6A	TM7OC	AN10		
	NCTS3/ NRTS3	P51	A12	SBO9	KEY33			
	NCTS4/ NRTS4	P43	IRQ7B	RTCA				
	NCTS9/ NRTS9	P54	A9	SBO10	KEY36			
	NCTS10/ NRTS10	P57	A6	IRQ8	KEY39			
IIC	SCL0A	P05	SBT5A	SBT2A	AN13	DAOUT1C	IIC clock I/O pins	
	SCL0B	PD2	SBT2B	SBT8A	KEY18	AN24		
	SCL1A	P35	A13	SBT3A				
	SCL1B	P95	SBT3B	AN21	IRX0A			
	SCL2A	P42	SBT4A	IRQ7A	NMIRQ			
	SCL3A	PD4	IRQ1B	KEY20	AN26	IRX1A		
	SCL4A	PD6	TM12IOA	IRQ3B	KEY22	AN28		CRX1A
	SCL5A	PA4	SBCS11_0	TM21BKA	KEY28	AN4		
	SCL6A	P92	SBT0B	TM18IOA	AN18			
	SCL7A	P23	IRQ3A					
	SDA0A	P03	SBO5A	SBO2A	AN11	DAOUT1B		IIC data I/O pins (Pin change is possible)
	SDA0B	PD0	SBO2B	SBO8A	KEY16	AN22		
	SDA1A	P33	A15	SBO3A				
	SDA1B	P93	SBO3B	AN19				
	SDA2A	P41	SBO4A	IRQ6				
	SDA3A	PD3	IRQ0B	KEY19	AN25	ITX1A		
	SDA4A	PD5	IRQ2B	KEY21	AN27	CTX1A		
SDA5A	PA3	SBCS11_1	TM22IOA	KEY27	AN3	DAOUT0B		
SDA6A	P90	SBO0B	TM17IOA	AN16	CTX0A	LINTXDB		
SDA7A	P22	NCS2	IRQ2A					
LIN	LINTXDA	P14	SBO0A	NWE1			LIN data transmission pins (Pin change is possible)	
	LINTXDB	P90	SBO0B	SDA6A	TM17IOA	AN16		(CTX0A) *2

	Pin	Other Function						Description
LIN	LINRXDA	P15	SBI0A	NRE	AN31			LIN data reception pins (Pin change is possible)
	LINRXDB	P91	SBI0B	AN17	(CRX0A) *2			
CAN *2	CTX0A	P90	SBO0B	SDA6A	TM17IOA	AN16	LINTXDB	CAN data transmission pin
	CTX1A	PD5	SDA4A	IRQ2B	KEY21	AN27		
	CRX0A	P91	SBI0B	AN17	LINRXDB			CAN data reception pin
	CRX1A	PD6	SCL4A	TM12IOA	IRQ3B	KEY22	AN28	
IEBus *3	ITX0A	P94	SBI3B	TM19IOA	AN20			IEBus data transmission pin
	ITX1A	PD3	SDA3A	IRQ0B	KEY19	AN25		IEBus data reception pin
	IRX0A	P95	SBT3B	SCL1B	AN21			
	IRX1A	PD4	SCL3A	IRQ1B	KEY20	AN26		
A/D converter	AN0	PA0	SBO7A	SBCS11_4	KEY24			Analog input pins
	AN1	PA1	SBI7A	SBCS11_3	KEY25	DAOUT0A		
	AN2	PA2	SBT7A	SBCS11_2	KEY26			
	AN3	PA3	SDA5A	SBCS11_1	TM22IOA	KEY27	DAOUT0B	
	AN4	PA4	SCL5A	SBCS11_0	TM21BKA	KEY28		
	AN5	PA5	SBO11	TM21GCP A	KEY29	DAOUT0C		
	AN6	PA6	SBI11	TM21IOA	KEY30			
	AN7	PA7	SBT11	TM20IOA	KEY31			
	AN8	P00	SBO1B	SBO6A	TM7IOA			
	AN9	P01	SBI1B	SBI6A	TM7OB	DAOUT1A		
	AN10	P02	SBT1B	SBT6A	NCTS2/ NRTS2	TM7OC		
	AN11	P03	SBO5A	SDA0A	SBO2A	DAOUT1B		
	AN12	P04	SBI5A	SBI2A				
	AN13	P05	SBT5A	SCL0A	SBT2A	DAOUT1C		
	AN14	P10	TM0IO	OCD_SDA				
	AN15	P11	TM1IO	OCD_SCL				
	AN16	P90	SBO0B	SDA6A	TM17IOA	CTX0A	LINTXDB	
	AN17	P91	SBI0B	CRX0A	LINRXDB			
	AN18	P92	SBT0B	SCL6A	TM18IOA			
	AN19	P93	SBO3B	SDA1B				
	AN20	P94	SBI3B	TM19IOA	ITX0A			
	AN21	P95	SBT3B	SCL1B	IRX0A			
	AN22	PD0	SBO2B	SBO8A	SDA0B	KEY16		
	AN23	PD1	SBI2B	SBI8A	KEY17			
	AN24	PD2	SBT2B	SBT8A	SCL0B	KEY18		
	AN25	PD3	SDA3A	IRQ0B	KEY19	ITX1A		
	AN26	PD4	SCL3A	IRQ1B	KEY20	IRX1A		
	AN27	PD5	SDA4A	IRQ2B	KEY21	CTX1A		
	AN28	PD6	SCL4A	TM12IOA	IRQ3B	KEY22	CRX1A	
	AN29	PD7	TM12IOB	IRQ4B	KEY23			
	AN30	P13	NWE0	TM20IOB	IRQ5B	NWDOVF2		
AN31	P15	NRE	SBI0A	LINRXDA				
D/A converter	DAOUT0A	PA1	SBI7A	SBCS11_3	KEY25	AN1		Analog output pins
	DAOUT0B	PA3	SDA5A	SBCS11_1	TM22IOA	KEY27	AN3	
	DAOUT0C	PA5	SBO11	TM21GCP A	KEY29	AN5		
	DAOUT1A	P01	SBI1B	SBI6A	TM7OB	AN9		
	DAOUT1B	P03	SBO5A	SDA0A	SBO2A	AN11		
DAOUT1C	P05	SBT5A	SCL0A	SBT2A	AN13			
RTC	RTCA	P43	NCTS4/ NRTS4	IRQ7B				Real time clock output pins



I/O port	Pin	Other Function						Description
P00-P06	P00	SBO1B	SBO6A	TM7IOA	AN8			General Purpose I/O port 0
	P01	SBI1B	SBI6A	TM7OB	AN9	DAOUT1A		
	P02	SBT1B	SBT6A	NCTS2/ NRTS2	TM7OC	AN10		
	P03	SBO5A	SDA0A	SBO2A	AN11	DAOUT1B		
	P04	SBI5A	SBI2A	AN12				
	P05	SBT5A	SCL0A	SBT2A	AN13	DAOUT1C		
	P06							
P10-P16	P10	TM0IO	AN14	OCD_SDA				General Purpose I/O port 1
	P11	TM1IO	AN15	OCD_SCL				
	P12	TM2IO	TM22IOB					
	P13	NWE0	TM20IOB	IRQ5B	AN30	NWDOVF2		
	P14	NWE1	SBO0A	LINTXDA				
	P15	NRE	SBI0A	AN31	LINRXDA			
	P16	SBT0A						
P20-P25	P20	NDK	IRQ0A					General Purpose I/O port 2
	P21	NCS1	IRQ1A					
	P22	NCS2	SDA7A	IRQ2A				
	P23	SCL7A	IRQ3A					
	P24	IRQ4A						
	P25	A17	NCTS1/ NRTS1	IRQ5A				
	P30-P35	P30	A20	SBO1A				
P31	A19	SBI1A						
P32	A18	SBT1A						
P33	A15	SDA1A	SBO3A					
P34	A14	SBI3A	TM4IOA					
P35	A13	SCL1A	SBT3A					
P40-P47	P40	SBI4A	TM11IOB				General Purpose I/O port 4	
	P41	SBO4A	SDA2A	IRQ6				
	P42	SBT4A	SCL2A	IRQ7A	NMIRQ			
	P43	NCTS4/ NRTS4	IRQ7B	RTCA				
	P44	OSCO						
	P45	OSCI						
	P46	XI						
P47	XO							
P50-P57	P50	A16	TM4IOB	KEY32			General Purpose I/O port 5	
	P51	A12	SBO9	NCTS3/ NRTS3	KEY33			
	P52	A11	SBI9	KEY34				
	P53	A10	SBT9	KEY35				
	P54	A9	NCTS9/ NRTS9	SBO10	KEY36			
	P55	A8	SBI10	KEY37				
	P56	A7	SBT10	KEY38				
P57	A6	NCTS10/ NRTS10	IRQ8	KEY39				
P60-P67	P60	A5	TM13IOA	KEY0			General Purpose I/O port 6	
	P61	A4	TM13IOB	KEY1				
	P62	A3	TM14IOA	KEY2				
	P63	A2	TM14IOB	KEY3				
	P64	D9	TM15IOA	KEY4				
	P65	D8	TM15IOB	KEY5				
	P66	D7	TM16IOA	KEY6				
P67	D6	TM16IOB	KEY7					



	Pin	Other Function					Description	
I/O port	P70	D5	TMMOD0	IRQ9A			General Purpose I/O port 7	
	P71	D4	TMMOD1	IRQ10A				
	P72	D3	TMMOD2	IRQ11A				
	P73	D2	TMMOD3	IRQ12A				
	P74	D1	TMMOD4	IRQ13A				
	P75	D0	TMMOD5	IRQ14A				
	P77	SYSCLK	TMMIO	IRQ15A				
	P80	A1	TM3IO	KEY8	LED0		General Purpose I/O port 8	
	P81	A0	TM8IOA	KEY9	LED1			
	P82	D15	TM8IOB	KEY10	LED2			
	P83	D14	TM9IOA	KEY11	LED3			
	P84	D13	TM9IOB	KEY12	LED4			
	P85	D12	TM10IOA	KEY13	LED5			
	P86	D11	TM10IOB	KEY14	LED6			
	P87	D10	TM11IOA	KEY15	LED7			
	P90	SBO0B	SDA6A	TM17IOA	AN16	CTX0A	LINTXDB	General Purpose I/O port 9
	P91	SBI0B	AN17	CRX0A	LINRXDB			
	P92	SBT0B	SCL6A	TM18IOA	AN18			
	P93	SBO3B	SDA1B	AN19				
	P94	SBI3B	TM19IOA	AN20	ITX0A			
	P95	SBT3B	SCL1B	AN21	IRX0A			
	PA0	SBO7A	SBCS11_4	KEY24	AN0			
	PA1	SBI7A	SBCS11_3	KEY25	AN1	DAOUT0A		General Purpose I/O port A
	PA2	SBT7A	SBCS11_2	KEY26	AN2			
	PA3	SDA5A	SBCS11_1	TM22IOA	KEY27	AN3	DAOUT0B	
	PA4	SCL5A	SBCS11_0	TM21BKA	KEY28	AN4		
	PA5	SBO11	TM21GCP A	KEY29	AN5	DAOUT0C		
	PA6	SBI11	TM21IOA	KEY30	AN6			
	PA7	SBT11	TM20IOA	KEY31	AN7			
	PD0	SBO2B	SBO8A	SDA0B	KEY16	AN22		General Purpose I/O port D
	PD1	SBI2B	SBI8A	KEY17	AN23			
	PD2	SBT2B	SBT8A	SCL0B	KEY18	AN24		
	PD3	SDA3A	IRQ0B	KEY19	AN25	ITX1A		
	PD4	SCL3A	IRQ1B	KEY20	AN26	IRX1A		
	PD5	SDA4A	IRQ2B	KEY21	AN27	CTX1A		
	PD6	SCL4A	TM12IOA	IRQ3B	KEY22	AN28	CRX1A	
	PD7	TM12IOB	IRQ4B	KEY23	AN29			
	LED0	P80	A1	TM3IO	KEY8			LED drive pins
	LED1	P81	A0	TM8IOA	KEY9			
	LED2	P82	D15	TM8IOB	KEY10			
	LED3	P83	D14	TM9IOA	KEY11			
	LED4	P84	D13	TM9IOB	KEY12			
	LED5	P85	D12	TM10IOA	KEY13			
	LED6	P86	D11	TM10IOB	KEY14			
LED7	P87	D10	TM11IOA	KEY15				
	OCD_SDA	P10	TM0IO	AN14				
	OCD_SCL	P11	TM1IO	AN15				
	P77	SYSCLK	TMMIO	IRQ15A				



	Pin	Other Function						Description
I/O port	P80	A1	TM3IO	KEY8	LED0			General Purpose I/O port 8
	P81	A0	TM8IOA	KEY9	LED1			
	P82	D15	TM8IOB	KEY10	LED2			
	P83	D14	TM9IOA	KEY11	LED3			
	P84	D13	TM9IOB	KEY12	LED4			
	P85	D12	TM10IOA	KEY13	LED5			
	P86	D11	TM10IOB	KEY14	LED6			
	P87	D10	TM11IOA	KEY15	LED7			
	P90	SBO0B	SDA6A	TM17IOA	AN16	CTX0A	LINTXDB	
P91	SBI0B	AN17	CRX0A	LINRXDB				
P92	SBT0B	SCL6A	TM18IOA	AN18				
P93	SBO3B	SDA1B	AN19					
P94	SBI3B	TM19IOA	AN20	ITX0A				
P95	SBT3B	SCL1B	AN21	IRX0A				
P96	IRQ0C							
P97	IRQ1C							
PA0	SBO7A	SBCS11_4	KEY24	AN0			General Purpose I/O port A	
PA1	SBI7A	SBCS11_3	KEY25	AN1	DAOUT0A			
PA2	SBT7A	SBCS11_2	KEY26	AN2				
PA3	SDA5A	SBCS11_1	TM22IOA	KEY27	AN3	DAOUT0B		
PA4	SCL5A	SBCS11_0	TM21BKA	KEY28	AN4			
PA5	SBO11	TM21GCP A	KEY29	AN5	DAOUT0C			
PA6	SBI11	TM21IOA	KEY30	AN6				
PA7	SBT11	TM20IOA	KEY31	AN7				
PB0	SBO4C	TM21GCP B						General Purpose I/O port B
PB1	SBI4C	TM21BKB						
PB2	SBT4C	TM21IOB						
PB3	SBO8B							
PB4	SBI8B							
PB5	SBT8B							
PB6								
PB7								
PC0	SBO4B	SBO7B	SDA2B				General Purpose I/O port C	
PC1	SBI4B	SBI7B						
PC2	SBT4B	SBT7B	SCL2B					
PC3	CTX1B							
PC4	CRX1B							
PC5								
PC6								
PD0	SBO2B	SBO8A	SDA0B	KEY16	AN22		General Purpose I/O port D	
PD1	SBI2B	SBI8A	KEY17	AN23				
PD2	SBT2B	SBT8A	SCL0B	KEY18	AN24			
PD3	SDA3A	IRQ0B	KEY19	AN25	ITX1A			
PD4	SCL3A	IRQ1B	KEY20	AN26	IRX1A			
PD5	SDA4A	IRQ2B	KEY21	AN27	CTX1A			
PD6	SCL4A	TM12IOA	IRQ3B	KEY22	AN28	CRX1A		
PD7	TM12IOB	IRQ4B	KEY23	AN29				



	Pin	Other Function					Description
I/O port	PE0	CTX0B					General Purpose I/O port E
	PE1	CRX0B					
	PE2						
	PE3	ITX1B					
	PE4	IRX1B					
	PE5	ITX0B					
	PE6	IRX0B					
	PF0	SBO5B					General Purpose I/O port F
	PF1	SBI5B					
	PF2	SBT5B					
	PF3	SBO6B					
	PF4	SBI6B	SBCS11_7				
	PF5	SBT6B	SBCS11_6				
	PG0	IRQ2C					General Purpose I/O port G
PG1	IRQ3C						
PG2							
PG3							
PG4							
PG5							
PG6							
PH0	IRQ4C					General Purpose I/O port H	
PH1	IRQ5C						
LED	LED0	P80	A1	TM3IO	KEY8		
	LED1	P81	A0	TM8IOA	KEY9		
	LED2	P82	D15	TM8IOB	KEY10		
	LED3	P83	D14	TM9IOA	KEY11		
	LED4	P84	D13	TM9IOB	KEY12		
	LED5	P85	D12	TM10IOA	KEY13		
	LED6	P86	D11	TM10IOB	KEY14		
	LED7	P87	D10	TM11IOA	KEY15		
OCD	OCD_SDA	P10	TM0IO	AN14			Data I/O pin for on-chip debug function
	OCD_SCL	P11	TM1IO	AN15			Clock input pin for on-chip debug function

*1 Refer to [1.8.2 Unused pins] and [1.8.5 Power Supply Circuit] for detail about note of VDD and function control pins.

*2 CAN-embedded series only.

*3 IEBus-embedded series only.

1.6 Electrical Characteristics

This LSI Manual describes a standard specification (Representative : MN103LF40R).

When using this LSI, consult our sales offices for the product specifications.

Structure	CMOS integrated circuit
Application	General purpose
Function	CMOS 32-bit, single chip microcomputer
Connection	Refer to [Figure:1.5.1]

1.6.1 Absolute Maximum Ratings

A. Absolute Maximum Ratings *1 *2 *3 *4

V_{SS} = 0.0 V

Parameter	Symbol	Rating	Unit		
A1	Power supply voltage 1 *5	V _{DD50A}	-0.3 to +7.0	V	
A2	Power supply voltage 2 *5	AV _{DDA}	-0.3 to +7.0		
A3	Input pin voltage	V _{I1}	-0.3 to V _{DD50} + 0.3 (upper limit:7.0)	V	
A4	I/O pin voltage (Other than PE1, PC4)	V _{IO1}	-0.3 to V _{DD50} + 0.3 (upper limit:7.0)		
A5	I/O pin voltage (PE1, PC4)	V _{IO2}	-0.3 to +7.0		
A6	Average output current *1	PA5, PA7	±22.5	mA	
		Other than PA5, PA7	±7.5		
A7	Power dissipation *6	T _{OPR} = 85°C	P _{D1}	400	mW
A8		T _{OPR} = 105°C	P _{D2}	300	
A9	Operating ambient temperature	T _{OPR}	-40 to +105	°C	
A10	Storage temperature	T _{STG}	-50 to +125		

*1 Applied to any 100 ms period.

*2 Connect at least one bypass capacitor of 0.1 μF or larger between each power supply pin (VDD50, AVDD) and GND near the LSI for preventing latch-up.

*3 Connect appropriate capacitor of 1 μF to 4 μF between VOUT18 pin and GND for the internal power voltage stabilization near the LSI.
Also, connect one or more capacitors of 1 μF or large between VDD50 pin and VSS.

*4 The absolute maximum ratings are the limit values beyond which the LSI may be damaged LSI operation is not guaranteed.

*5 Using V_{DD50} = AV_{DD}

*6 Calculated using a 4-layer printed circuit board (75 mm × 75 mm × 0.8 mm).

1.6.2 Operating Conditions

B. Operating Conditions

$V_{SS} = 0\text{ V}$
 $T_a = -40\text{ °C to }+105\text{ °C}$

Parameter	Symbol	Conditions	Rating			Unit
			MIN	TYP	MAX	
Power supply voltage *7						
B1	Power supply voltage (VDD50)	V_{DD50}	2.2	3.3	5.5	V
B2	Power supply voltage(AVDD)	A_{VDD}		V_{DD50}		
B3	Reference power supply pin for the A/D converter (VREFH)	V_{REFH}		V_{DD50}		
B4	RAM Retention power supply voltage (VDD50)	V_{DD50_S} In STOP mode	1.8	3.3	5.5	
Operating speed						
B5	Instruction execution time	t_{c1}	$V_{DD50} = 2.2\text{ V to }5.5\text{ V}$ Normal mode, clkcpu 48 MHz	20.8		ns
		t_{c2}	$V_{DD50} = 2.2\text{ V to }5.5\text{ V}$ Slow mode, clkcpu 32.768 kHz	61		μs
Oscillation pin						
B6	Oscillation frequency	f_{OSC}	$V_{DD50} = 2.2\text{ V to }5.5\text{ V}$	4	20	MHz
B7		f_x	$V_{DD50} = 2.2\text{ V to }5.5\text{ V}$		32.768	kHz
B8	External capacitor *8	C_{11}			20	pF
B9		C_{12}			20	
B10		C_{21}			47	
B11		C_{22}			47	
B12	Internal feedback resistor	R_{f1}			1.22	$M\Omega$
B13		R_{f2}			6.78	

*7 $V_{REFH} = A_{VDD} = V_{DD50}$

*8 Connect external capacitors suited for the used oscillator.
For external capacity value, consult the oscillator manufacturer and perform matching tests enough for determining appropriate value.

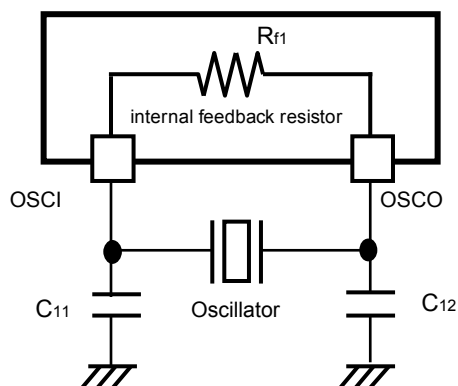

Figure:1.6.1 Oscillation Circuit 1

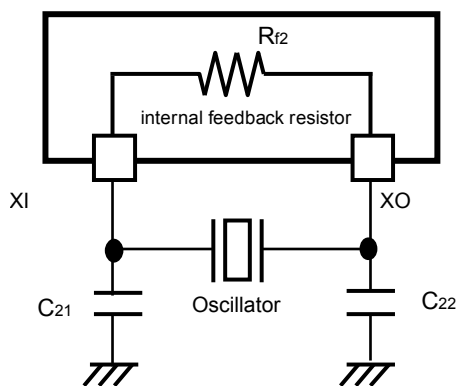

Figure:1.6.2 Oscillation Circuit 2

$V_{DD50} = AV_{DD} = V_{REFH} = 2.2\text{ V to }5.5\text{ V}$
 $V_{SS} = 0\text{ V}$
 $T_a = -40\text{ }^{\circ}\text{C to }+105\text{ }^{\circ}\text{C}$

Parameter	Symbol	Conditions	Rating			Unit	
			MIN	TYP	MAX		
External clock input OSCI (OSCO is unconnected)							
B14	Clock frequency	f_{OSC}	$V_{DD50} = 2.2\text{ V to }5.5\text{ V}$	4		20	MHz
B15	High-level pulse width *9	t_{wh1}	Figure:1.6.3	20			ns
B16	Low-level pulse width *9	t_{wl1}		20			
B17	Rising time *10	t_{wr1}	Figure:1.6.3			2.5	
B18	Falling time *10	t_{wf1}				2.5	
External clock input XI (XO is unconnected)							
B19	Clock frequency	f_X	$V_{DD50} = 2.2\text{ V to }5.5\text{ V}$		32.768		kHz
B20	High-level pulse width *9	t_{wh2}	Figure:1.6.4	5			μs
B21	Low-level pulse width *9	t_{wl2}		5			
B22	Rising time *10	t_{wr2}	Figure:1.6.4			0.5	
B23	Falling time *10	t_{wf2}				0.5	

*9 The clock duty ratio should be 45% to 55%

*10 Rising time and Falling time differ depending on the oscillation frequency.

The MAX value is not a specified value but a rough value.

Consult the oscillator manufacturer and perform matching tests enough for determining appropriate value.

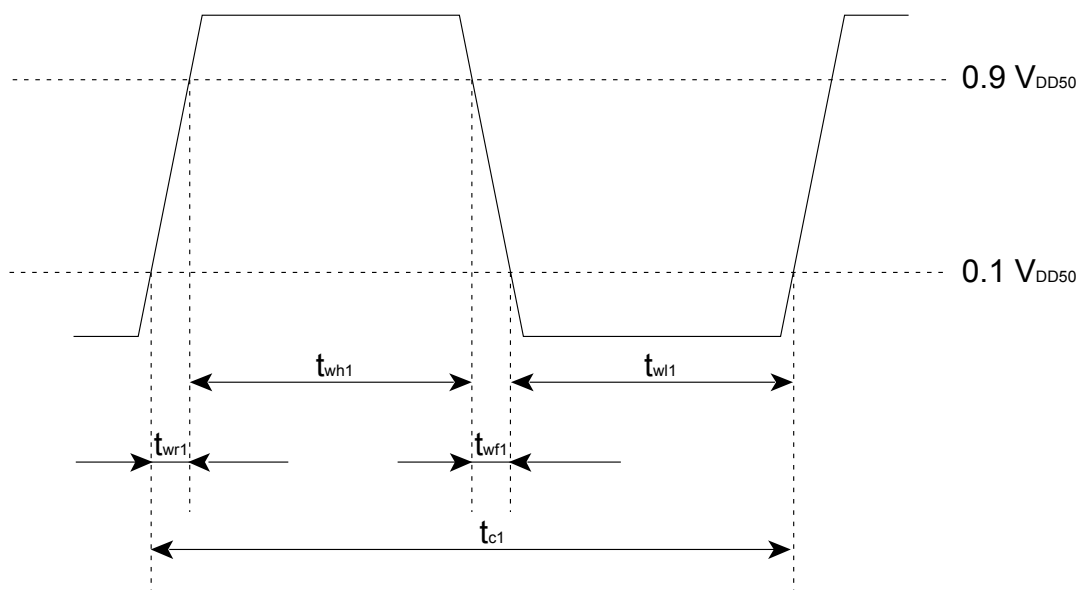

Figure:1.6.3 OSCI Timing Chart

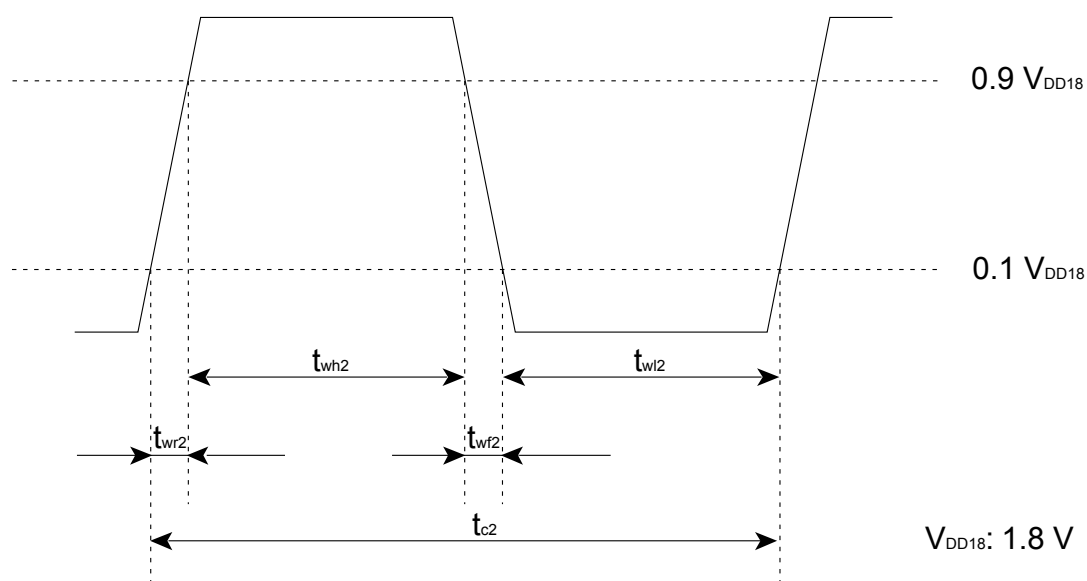

Figure:1.6.4 XI Timing Chart

C. DC Characteristics

$V_{DD50} = AV_{DD} = V_{REFH} = 2.2 \text{ V to } 5.5 \text{ V}$
 $V_{SS} = 0 \text{ V}$
 $T_a = -40 \text{ }^\circ\text{C to } +105 \text{ }^\circ\text{C}$

Parameter	Symbol	Conditions	Rating			Unit	
			MIN	TYP	MAX		
Power supply current *11							
C1 C2 C3	Power supply current in NORMAL Mode	I_{DD1}	clkcpu = 20 MHz [f _{OSC} = 20 MHz, PLL OFF, f _{rc} OFF]	$V_{DD50} = 3.3 \text{ V}$	13	26	mA
		I_{DD2}		$V_{DD50} = 5.0 \text{ V}$	12		
		I_{DD3}	clkcpu = 48 MHz [f _{OSC} = 12 MHz, PLL multiple by 8, f _{rc} OFF]	$V_{DD50} = 3.3 \text{ V}$	29	58	
		I_{DD4}		$V_{DD50} = 5.0 \text{ V}$	27		
		I_{DD5}	clkcpu = 48 MHz [f _X = 32.768 kHz, PLL multiple by 2930, f _{rc} OFF, f _{OSC} OFF]	$V_{DD50} = 3.3 \text{ V}$	28	56	
		I_{DD6}		$V_{DD50} = 5.0 \text{ V}$	26		
C4	Power supply current in SLOW Mode	I_{DD7}	clkcpu = 32.768 kHz, $V_{DD50} = 3.3 \text{ V}$ [f _X = 32.768 kHz, PLL OFF, f _{rc} OFF, f _{OSC} OFF, main regulator OFF] (At used the Low-Power Cache)		25	350	μA
C5	Power supply current in HALT mode	I_{DD8}	clkcpu = 20 MHz, $V_{DD50} = 3.3 \text{ V}$ [f _{OSC} = 20 MHz, PLL OFF, f _{rc} OFF, f _{rcx} OFF]		3	6	mA
C6		I_{DD9}	clkcpu = 32 kHz, $V_{DD50} = 3.3 \text{ V}$ [f _{OSC} = 4 MHz, PLL OFF, f _{rc} OFF, f _{rcx} OFF, main regulator OFF]		300	720	μA
C7		I_{DD10}	clkcpu = 32.768 kHz, $V_{DD50} = 3.3 \text{ V}$ [f _X = 32.768 kHz, PLL OFF, f _{rc} OFF, f _{rcx} OFF, f _{OSC} OFF, main regulator OFF]		12	330	
C8	Power supply current in STOP mode	I_{DD11}	f _{OSC} OFF f _X OFF f _{rc} OFF f _{rcx} OFF main regulator OFF	Ta = 25 °C $V_{DD50} = 5.0 \text{ V}$	7		μA
		I_{DD12}		Ta = 25 °C $V_{DD50} = 3.3 \text{ V}$	7		
		I_{DD13}		Ta = 105 °C $V_{DD50} = 3.3 \text{ V}$		320	

*11 I/O pin are all output setting (unloaded condition)

$V_{DD50} = AV_{DD} = V_{REFH} = 2.2 \text{ V to } 5.5 \text{ V}$
 $V_{SS} = 0 \text{ V}$
 $T_a = -40 \text{ }^\circ\text{C to } +105 \text{ }^\circ\text{C}$

Parameter	Symbol	Conditions	Rating			Unit	
			MIN	TYP	MAX		
Input pin 1 OCDMOD, ATRST							
C13	Input voltage High-level	V_{IH1}	-	$0.7V_{DD50}$		V_{DD50}	V
C14	Input voltage Low-level	V_{IL1}	-	0		$0.3V_{DD50}$	
C15	Input leakage current	I_{LK1}	$V_{IN} = V_{SS} \text{ or } V_{DD50}$			± 5	μA
Input pin 2 NRST							
C16	Input voltage High-level	V_{IH2}	-	$0.7V_{DD50}$		V_{DD50}	V
C17	Input voltage Low-level	V_{IL2}	-	0		$0.3V_{DD50}$	
C18	Internal pull-up resistance	R_{PU2}	$V_{DD50} = 3.3 \text{ V}, V_{IN} = 0 \text{ V}$	15	30	60	$\text{k}\Omega$
I/O pin 1 P00 to P07, P10 to P16, P20 to P25, P30 to P35, P40 to P47, P50 to P57, P60 to P67, P70 to P77, P90 to P97, PA0 to PA4, PB0 to PB7, PC0 to PC3, PC5, PC6, PD0 to PD7, PE0, PE2 to PE7, PF0 to PF6, PG0 to PG6, PH0, PH1, PJ0 to PJ7, PK0 to PK7, PL0 to PL7, PM0 to PM7							
C19	Input voltage High-level	V_{IH3}	-	$0.7V_{DD50}$		V_{DD50}	V
C20	Input voltage Low-level	V_{IL3}	-	0		$0.3V_{DD50}$	
C21	Input leakage current	I_{LK3}	$V_{IN} = V_{SS} \text{ or } V_{DD50}$			± 5	μA
C22	Internal pull-up resistance	R_{PU3}	$V_{DD50} = 3.3 \text{ V}, V_{IN} = 0 \text{ V}$	15	30	60	$\text{k}\Omega$
C23	Output voltage High-level	V_{OH3}	$V_{DD50} = 3.3 \text{ V}, I_{OH} = -2.0 \text{ mA}$	2.7			V
C24	Output voltage Low-level	V_{OL3}	$V_{DD50} = 3.3 \text{ V}, I_{OL} = 2.0 \text{ mA}$			0.4	
I/O pin 2 PA5, PA7							
C25	Input voltage High-level	V_{IH4}	-	$0.7V_{DD50}$		V_{DD50}	V
C26	Input voltage Low-level	V_{IL4}	-	0		$0.3V_{DD50}$	
C27	Input leakage current	I_{LK4}	$V_{IN} = V_{SS} \text{ or } V_{DD50}$			± 5	μA
C28	Internal pull-up resistance	R_{PU4}	$V_{DD50} = 3.3 \text{ V}, V_{IN} = 0 \text{ V}$	15	30	60	$\text{k}\Omega$
C29	Output voltage High-level	V_{OH4}	$V_{DD50} = 3.3 \text{ V}, I_{OH} = -8.0 \text{ mA}$	2.7			V
C30	Output voltage Low-level	V_{OL4}	$V_{DD50} = 3.3 \text{ V}, I_{OL} = 8.0 \text{ mA}$			0.4	

$V_{DD50} = AV_{DD} = V_{REFH} = 2.2 \text{ V to } 5.5 \text{ V}$
 $V_{SS} = 0 \text{ V}$
 $T_a = -40 \text{ }^\circ\text{C to } +105 \text{ }^\circ\text{C}$

Parameter	Symbol	Conditions	Rating			Unit	
			MIN	TYP	MAX		
I/O pin 3 P80 to P87							
C31	Input voltage High-level	V_{IH5}	-	$0.7V_{DD50}$		V_{DD50}	V
C32	Input voltage Low-level	V_{IL5}	-	0		$0.3V_{DD50}$	
C33	Input leakage current	I_{LK5}	$V_{IN} = V_{SS}$ or V_{DD50}			± 5	μA
C34	Internal pull-up resistance	R_{PU5}	$V_{DD50} = 3 \text{ V}, V_{IN} = 0 \text{ V}$	15	30	60	$\text{k}\Omega$
C35	Output voltage High-level	V_{OH5}	$V_{DD50} = 3.3 \text{ V}, I_{OH} = -2.0 \text{ mA}$	2.7			V
C36	Output voltage Low-level 1	V_{OL5}	$V_{DD50} = 3.3 \text{ V}, I_{OL} = 2.0 \text{ mA}$			0.4	
C37	Output voltage Low-level 2	V_{OL5_2}	$V_{DD50} = 3.3 \text{ V}, I_{OL} = 8.0 \text{ mA}$ (P8LED = "1")			0.4	
I/O pin 4 PC4, PE1							
C38	Input voltage High-level	V_{IH6}	-	$0.7V_{DD50}$		5.5	V
C39	Input voltage Low-level	V_{IL6}	-	0		$0.3V_{DD50}$	
C40	Input leakage current	I_{LK6}	$V_{IN} = V_{SS}$ or V_{DD50}			± 5	μA
C41	Output voltage High-level	V_{OH6}	$V_{DD50} = 3.3 \text{ V}, I_{OH} = -2.0 \text{ mA}$	2.7			V
C42	Output voltage Low-level	V_{OL6}	$V_{DD50} = 3.3 \text{ V}, I_{OL} = 2.0 \text{ mA}$			0.4	

D.A/D Converter Characteristics *12

$V_{DD50} = AV_{DD} = 2.7\text{ V to }5.5\text{ V}$, $V_{REFH} = 2.7\text{ V to }AV_{DD}$
 $V_{SS} = 0\text{ V}$
 $T_a = -40\text{ }^\circ\text{C to }+105\text{ }^\circ\text{C}$

Parameter	Symbol	Conditions	Rating			Unit
			MIN	TYP	MAX	
D1	A/D converter operation power supply voltage	$V_{DD50} = AV_{DD}$	2.7		5.5	V
D2	Resolution				10	bit
D3	Non-linearity error	$AV_{DD} = V_{REFH}$ $V_{SS} = 0\text{ V}$			± 3	LSB
D4	Differential linearity error				± 3	
D5	Zero transition voltage				20	100
D6	Full-scale transition voltage		$AV_{DD}-100$	$AV_{DD}-20$		
D7	A/D conversion time	$AV_{DD} = 5.0\text{ V}$ $T_{AD} = 200\text{ ns}$, clkbus = 20 MHz	3.325			μs
D8		$AV_{DD} = 3.3\text{ V}$ $T_{AD} = 800\text{ ns}$, clkbus = 20 MHz	12.925			
D9		$T_{AD} = 15.26\text{ }\mu\text{s}$, clkbus = 20 MHz	244.31			
D10	Sampling time	T_{S1} $T_{AD} = 200\text{ ns}$	0.4		3.6	
D11		T_{S2} $T_{AD} = 15.26\text{ }\mu\text{s}$	30.52		274.68	
D12	Analog input voltage	V_{ADIN}	V_{SS}		V_{REFH}	V
D13	Analog input leakage current	$AV_{DD} = V_{REFH}$, $V_{SS} = 0\text{ V}$ At Channel OFF: $V_{ADIN} = 0\text{ V to }AV_{DD}$			± 5	μA
D14	Reference voltage pin input leakage current	$AV_{DD} = V_{REFH}$, $V_{SS} = 0\text{ V}$ At Channel OFF: $V_{ADIN} = 0\text{ V to }AV_{DD}$			± 5	
D15	Ladder resistance	R_{LADD} $AV_{DD} = V_{REFH}$, $V_{SS} = 0\text{ V}$	8.5	10.5	12.5	$\text{k}\Omega$

*12 Using $AV_{DD} \geq V_{REFH}$

The values of D3 to D6 and D10 to D15 are guaranteed on the condition of $AV_{DD} = V_{REFH} = 3.3\text{ V}$ and $V_{SS} = 0\text{ V}$ or $AV_{DD} = V_{REFH} = 5.0\text{ V}$ and $V_{SS} = 0\text{ V}$.

E.D/A converter characteristics *13

$V_{DD50} = AV_{DD} = 2.7\text{ V to }5.5\text{ V}$, $V_{REFH} = 2.7\text{ V to }AV_{DD}$
 $V_{SS} = 0\text{ V}$
 $T_a = -40\text{ }^\circ\text{C to }+105\text{ }^\circ\text{C}$

Parameter	Symbol	Conditions	Rating			Unit	
			MIN	TYP	MAX		
E1	D/A converter operation power supply voltage	$V_{DD50} = AV_{DD}$	2.7		5.5	V	
E2	Resolution				10	bit	
E3	Reference voltage Low-level	V_{REFL_DA}		V_{SS}		V	
E4	Reference voltage High-level	V_{REFH_DA}		AV_{DD}			
E5	Non-linearity error	NLE			± 3	LSB	
E6	Differential non-linearity error	DNLE			± 3		
E7	Zero-scale output voltage	V_{ZS}	D9 to D0 = ALL Low-level	0	20	mV	
E8	Full-scale output voltage	V_{FS}	D9 to D0 = ALL High-level	$AV_{DD}-40$	AV_{DD}		
E9	Minimum reference resistance	R_{REF}		28	40	52	k Ω
E10	Settling time	T_{SET}	External capacitor $C_L = 15\text{ pF}$			8	μs

*13 The values of E2 to E10 are guaranteed on the condition of $V_{DD50} = AV_{DD} = 3.3\text{ V}$ and $V_{SS} = 0\text{ V}$ or $V_{DD50} = AV_{DD} = 5.0\text{ V}$ and $V_{SS} = 0\text{ V}$.

1.6.3 AC Characteristics

F. AC Characteristics

The parameter used for the AC characteristic is integer. The range can be set and the setting condition are as follow. Refer to [Chapter 7 Bus Controller] of LSI User's Manual for setting method of each parameter.

Parameter	At reset releasing	Settable range		Setting Condition	
		MIN	MAX		
BCS	3	1	3	-	
EA	15	0	15	-	
BCE	31	2	31	Block 1,2	Set to $BCE > REN \geq EA$ and $BCE > WEN \geq EA$. At $EA=0$, set to $BCN > REN$.
REN	31	1	31	Block 1,2	Set to $[REN \geq EA]$.
WEN	31	1	31	Block 1,2	Set to $[WEN \geq EA]$.
DW	3	1	3	At $EA = 0$, set to $DW > 1$. At $EA \neq 0$, set to $DW > 0$.	

$V_{DD50} = AV_{DD} = V_{REFH} = 2.2 \text{ V to } 5.5 \text{ V}$
 $V_{SS} = 0 \text{ V}, C_L = 50 \text{ pF}$
 $T_a = -40 \text{ }^\circ\text{C to } +105 \text{ }^\circ\text{C}$

Parameter	Symbol	Conditions	Rating			Unit
			MIN	TYP	MAX	
Clock Timing. Refer to Figure:1.6.5.						
F1	System clock output cycle time	t_{CYC}	83.3			ns
F2	System clock output high-level pulse width	t_{CH}	$\frac{t_{CYC}}{2} - 15$			
F3	System clock output low-level pulse width	t_{CL}	$\frac{t_{CYC}}{2} - 15$			

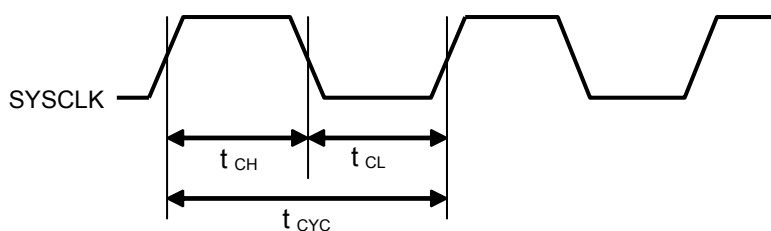
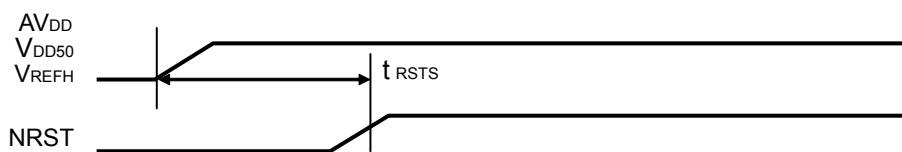

Figure:1.6.5 External Clock Timing

$V_{DD50} = AV_{DD} = V_{REFH} = 2.2\text{ V to }5.5\text{ V}$
 $V_{SS} = 0\text{ V}, C_L = 50\text{ pF}$
 $T_a = -40\text{ }^\circ\text{C to }+105\text{ }^\circ\text{C}$

Parameter	Symbol	Conditions	Rating			Unit
			MIN	TYP	MAX	
Reset timing/Power-On sequence. Refer to Figure:1.6.6						
F4	Reset release timing (NRST)	t_{RSTS}	400			μs
F5	Reset pulse width (NRST)	t_{RSTW}	400			ns
F6	Mode setup timing (OCDMOD)	t_{MODS}	100			

- Power-On Sequence



- Reset pulse width

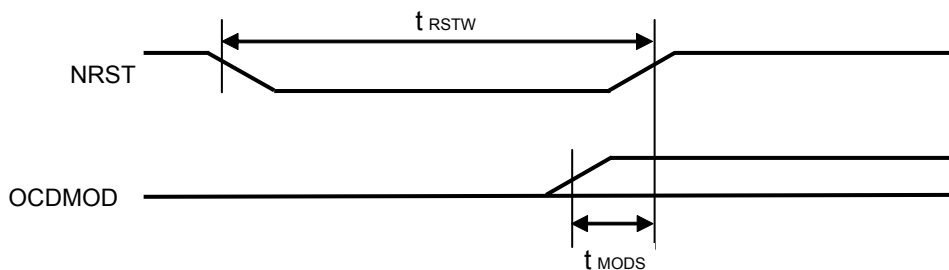

Figure:1.6.6 Power-On Sequence and Reset Pulse Width

$V_{DD50} = AV_{DD} = V_{REFH} = 2.2\text{ V to }5.5\text{ V}$
 $V_{SS} = 0\text{ V}, C_L = 50\text{ pF}$
 $T_a = -40\text{ }^\circ\text{C to }+105\text{ }^\circ\text{C}$

Parameter	Symbol	Conditions	Rating			Unit
			MIN	TYP	MAX	
Address/Data Separate mode. Refer to Figure:1.6.7, Figure:1.6.8. *16						
F7	Address delay time (A[20:0])	t_{AD}		$\frac{t_{CYC}}{n_{fr}} \times EA-10$		
F8	Address hold time (A[20:0])	t_{AH}	At reading	$\frac{t_{CYC}}{n_{fr}} \times (BCE-REN)-10$		
			At writing	$\frac{t_{CYC}}{n_{fr}} \times (BCE-WEN)-10$		
F9	Chip select signal falling delay time (NCS[2:1])	t_{CSDF}		$\frac{t_{CYC}}{n_{fr}} \times EA-10$		
F10	Chip select signal rising delay time (NCS[2:1])	t_{CSDR}	At reading	$\frac{t_{CYC}}{n_{fr}} \times (BCE-REN)-10$		
			At writing	$\frac{t_{CYC}}{n_{fr}} \times (BCE-WEN)-10$		
F11	Read data setup time (D[15:0])	t_{RDS}		60		ns
F12	Read data hold time (D[15:0])	t_{RDH}		0		
F13	Write data setup time (D[15:0])	t_{WDS}		$\frac{t_{CYC}}{n_{fr}} \times (WEN-EA)-15$		
F14	Write data hold time (D[15:0])	t_{WDH}		$\frac{t_{CYC}}{n_{fr}} \times (BCE-WEN)-15$		
F15	Data acknowledge signal setup time (NDK)	t_{DKS}		50		
F16	Data acknowledge signal hold time (NDK)	t_{DKH}		0		
F17	Read enable signal falling delay time (NRE)	t_{REDF}		$\frac{t_{CYC}}{n_{fr}} \times (BCS+EA)-10$		

$V_{DD50} = AV_{DD} = V_{REFH} = 2.2\text{ V to }5.5\text{ V}$
 $V_{SS} = 0\text{ V}, C_L = 50\text{ pF}$
 $T_a = -40\text{ }^\circ\text{C to }+105\text{ }^\circ\text{C}$

Parameter	Symbol	Conditions	Rating			Unit
			MIN	TYP	MAX	
Address/Data Separate mode. Refer to Figure:1.6.7, Figure:1.6.8. *16						
F18	Read enable signal pulse width (NRE)	t_{REW}	At fixed wait	$\frac{t_{CYC}}{n_{fr}} \times (\text{REN-EA})-10$		ns
		t_{HREW}	At handshake	$\frac{t_{CYC}}{n_{fr}} \times (\text{REN}+1)-10$		
F19	Write enable signal falling delay time (NWE[1:0])	t_{WEDF}		$\frac{t_{CYC}}{n_{fr}} \times (\text{BCS}+\text{EA})-10$		
F20	Write enable signal pulse width (NWE[1:0])	t_{WEW}	At fixed wait	$\frac{t_{CYC}}{n_{fr}} \times (\text{WEN-EA})-10$		
		t_{HWEW}	At handshake	$\frac{t_{CYC}}{n_{fr}} \times (\text{WEN}+1)-10$		

*16 The values of F7 to F20 are guaranteed on the condition of $V_{DD50} = 3.3\text{ V}$ and $V_{SS} = 0\text{ V}$.

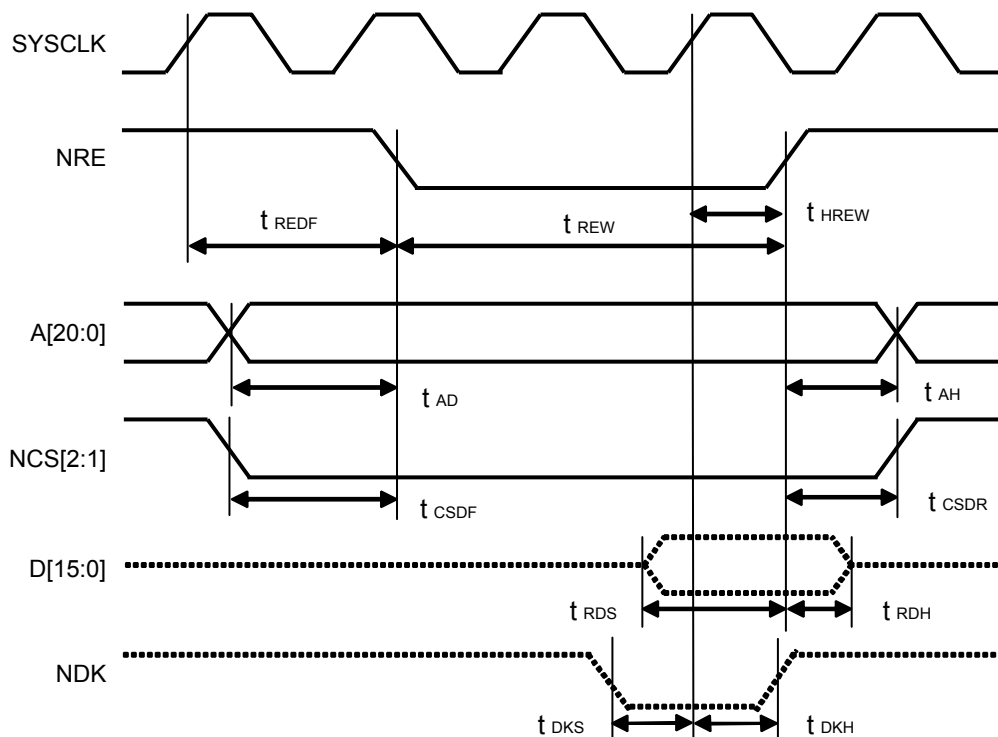

Figure:1.6.7 Separate Address/Data Synchronous Mode Read Timing

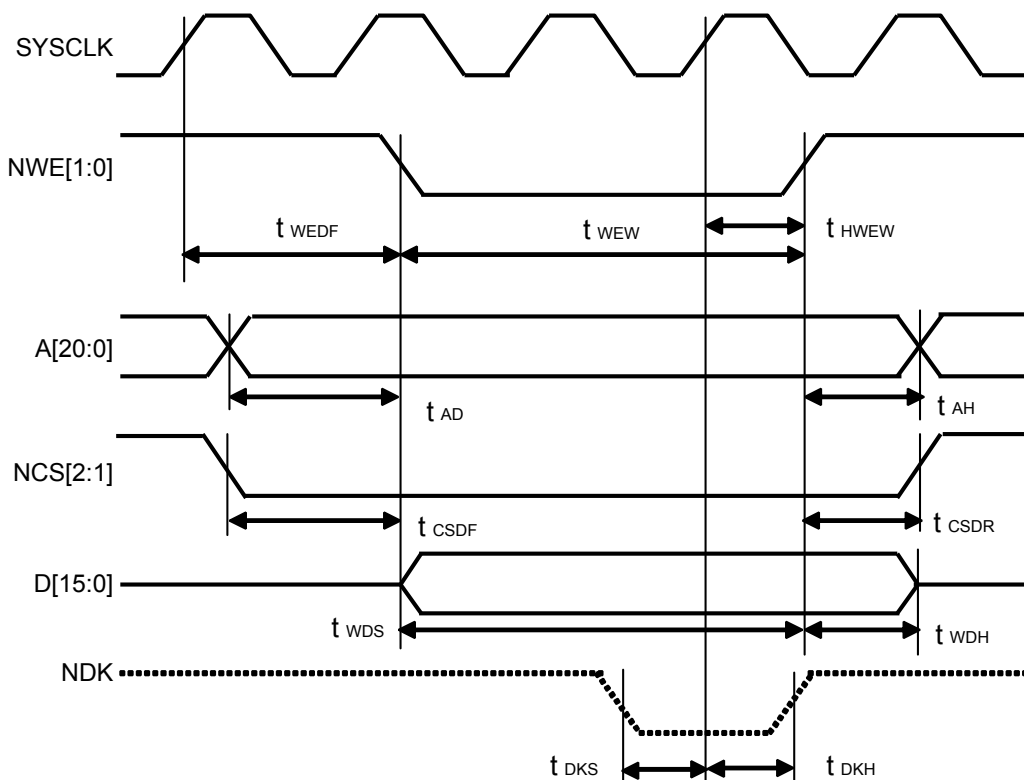

Figure:1.6.8 Separate Address/Data Synchronous Mode Write Timing

$V_{DD50} = AV_{DD} = V_{REFH} = 2.2 \text{ V to } 5.5 \text{ V}$
 $V_{SS} = 0 \text{ V}, C_L = 50 \text{ pF}$
 $T_a = -40 \text{ }^\circ\text{C to } +105 \text{ }^\circ\text{C}$

Parameter	Symbol	Conditions	Rating			Unit
			MIN	TYP	MAX	
Interrupt signal input timing Refer to Figure:1.6.9 *17						
F21	Non-maskable interrupt signal pulse width (NMIRQ)	t_{NMIW}		$\frac{t_{CYC}}{n_{fr}} \times 3$		ns
F22	Interrupt signal pulse width (IRQn)	t_{IRQW}		$\frac{t_{CYC}}{n_{fr}} \times 3$		

*17 The above-mentioned is standard without noise filter.

When the noise filter is used, the minimum pulse width is determined with the sampling clock.

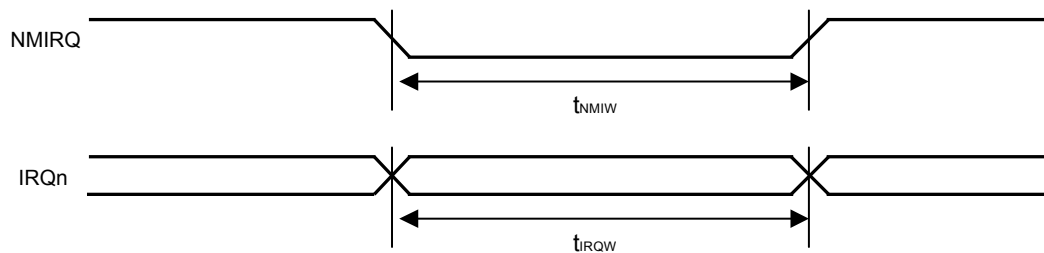

Figure:1.6.9 Interrupt Signal Input Timing

$V_{DD50} = AV_{DD} = V_{REFH} = 2.2\text{ V to }5.5\text{ V}$
 $V_{SS} = 0\text{ V}, C_L = 50\text{ pF}$
 $T_a = -40\text{ }^{\circ}\text{C to }+105\text{ }^{\circ}\text{C}$

Parameter	Symbol	Conditions	Rating			Unit
			MIN	TYP	MAX	
IIC signal I/O timing 1 (SCL clock frequency : max 100 kHz) Refer to Figure:1.6.10.						
F23	Bus free time (SDA0-2)	t_{BUF}		4.7		μS
F24	Hold time of start condition (SCL0-2)	$t_{HD;STA}$		4.0		
F25	Clock Low-level pulse width (SCL0-2)	t_{LOW}		4.7		
F26	Clock High-level pulse width (SCL0-2)	t_{HIGH}		4.0		
F27	Setup time of repeat start condition	$t_{SU;STA}$		4.7		
F28	Hold time of data (SDA0-2)	$t_{HD;DAT}$	At SDA output	300		ns
			At SDA input	0		
F29	Setup time of data (SDA0-2)	$t_{SU;DAT}$		250		
F30	Setup time of stop condition	$t_{SU;STO}$		4.0		μS
IIC signal I/O timing 2 (SCL clock frequency : max 400 kHz) Refer to Figure:1.6.10.						
F31	Bus free time (SDA0-2)	t_{BUF}		1.3		μS
F32	Hold time of start condition (SCL0-2)	$t_{HD;STA}$		0.6		
F33	Clock Low-level pulse width (SCL0-2)	t_{LOW}		1.3		
F34	Clock High-level pulse width (SCL0-2)	t_{HIGH}		0.6		
F35	Setup time of repeat start condition	$t_{SU;STA}$		0.6		
F36	Hold time of data (SDA0-2)	$t_{HD;DAT}$	At SDA output	300		ns
			At SDA input	0		
F37	Setup time of data (SDA0-2)	$t_{SU;DAT}$		100		
F38	Setup time of stop condition	$t_{SU;STO}$		0.6		μS

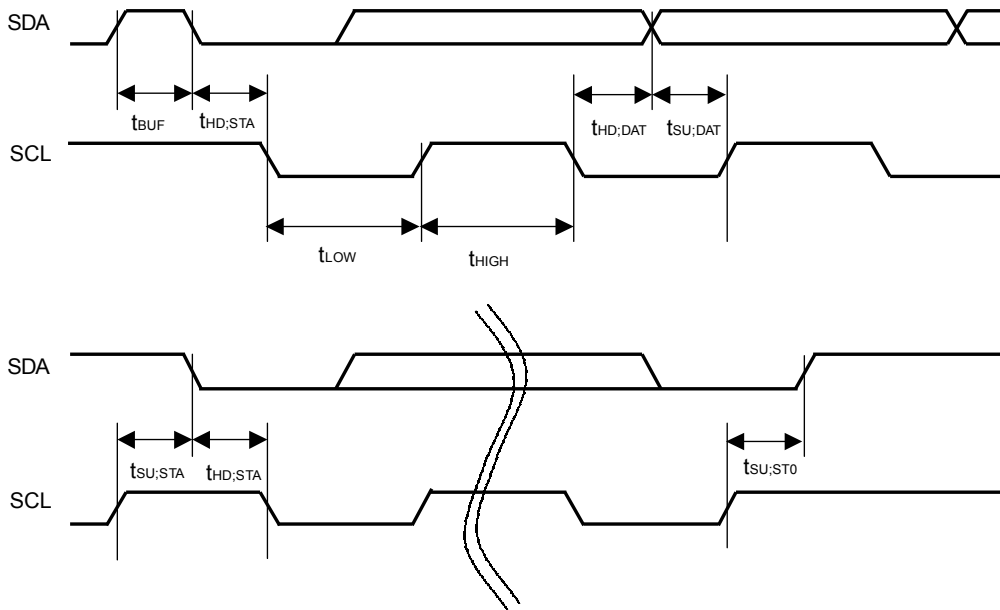

Figure:1.6.10 IIC Signal Timing

$V_{DD50} = AV_{DD} = V_{REFH} = 2.2\text{ V to }5.5\text{ V}$
 $V_{SS} = 0\text{ V}, C_L = 50\text{ pF}$
 $T_a = -40\text{ }^{\circ}\text{C to }+105\text{ }^{\circ}\text{C}$

Parameter	Symbol	Conditions	Rating			Unit
			MIN	TYP	MAX	
Serial interface 0 to 10, at Clock Synchronous, I/O timing 1 (at master (SBT polarity "H")), refer to Figure:1.6.11						
F39	Cycle time	f_{S_CYCLE1}		300		ns
F40	SBT High width	t_{S_HIGH1}		$(t_{S_CYCLE1}/2)-17$		
F41	SBT Low width	t_{S_LOW1}		$(t_{S_CYCLE1}/2)-17$		
F42	SBI/SBO setup time	t_{S_SET1}		11		
F43	SBI/SBO hold time	t_{S_HOLD1}		11		
F44	SBO output delay	t_{S_OPD1}			86	
Serial interface 0 to 10, at Clock Synchronous, I/O timing 2 (at slave (SBT polarity "H")), refer to Figure:1.6.11						
F45	Cycle time	f_{S_CYCLE1}		300		ns
F46	SBT High width	t_{S_HIGH1}		133		
F47	SBT Low width	t_{S_LOW1}		133		
F48	SBI/SBO setup time	t_{S_SET1}		11		
F49	SBI/SBO hold time	t_{S_HOLD1}		11		
F50	SBO output delay	t_{S_OPD1}			86	

$V_{DD50} = AV_{DD} = V_{REFH} = 2.2\text{ V to }5.5\text{ V}$
 $V_{SS} = 0\text{ V}, C_L = 50\text{ pF}$
 $T_a = -40\text{ }^\circ\text{C to }+105\text{ }^\circ\text{C}$

Parameter	Symbol	Conditions	Rating			Unit
			MIN	TYP	MAX	
Serial interface 0 to 4, 9, 10, at Clock Synchronous, I/O timing 3 (at master (SBT polarity "L")), refer to Figure:1.6.12						
F51	Cycle time	f_{S_CYCLE2}	300			ns
F52	SBT High width	t_{S_HIGH2}	$(t_{S_CYCLE2}/2)-17$			
F53	SBT Low width	t_{S_LOW2}	$(t_{S_CYCLE2}/2)-17$			
F54	SBI/SBO setup time	t_{S_SET2}	11			
F55	SBI/SBO hold time	t_{S_HOLD2}	11			
F56	SBO output delay	t_{S_OPD2}			86	
Serial interface 0 to 4, 9, 10, at Clock Synchronous, I/O timing 4 (at slave (SBT polarity "L")), refer to Figure:1.6.12						
F57	Cycle time	f_{S_CYCLE2}	300			ns
F58	SBT High width	t_{S_HIGH2}	133			
F59	SBT Low width	t_{S_LOW2}	133			
F60	SBI/SBO setup time	t_{S_SET2}	11			
F61	SBI/SBO hold time	t_{S_HOLD2}	11			
F62	SBO output delay	t_{S_OPD2}			86	

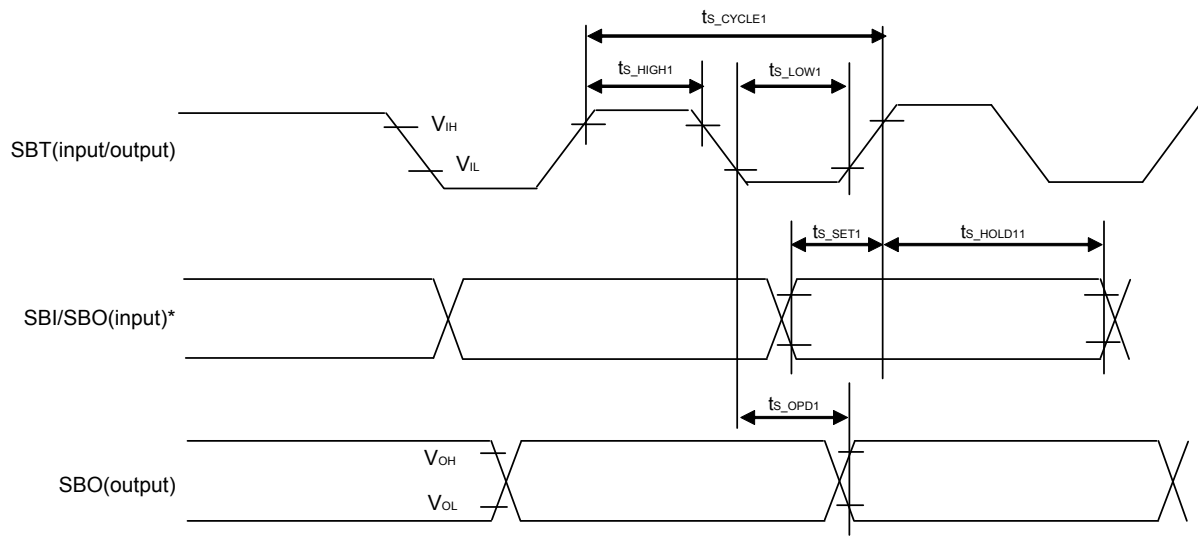

*SBO input function has SIF0 to 4, 9 and 10 only.

Figure:1.6.11 SIF Signal Timing 1

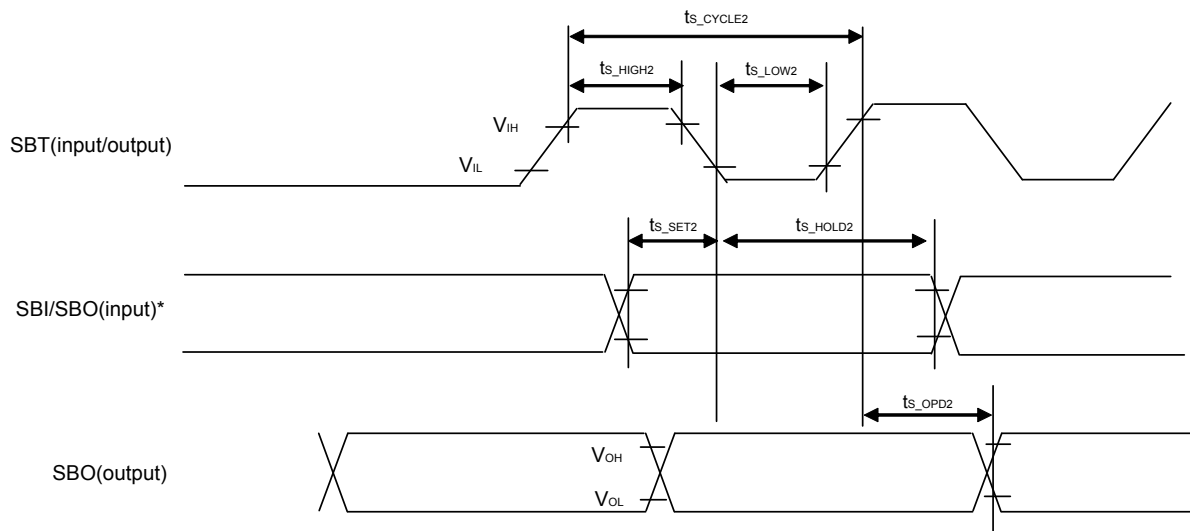

*SBO input function has SIF0 to 4, 9 and 10 only.

Figure:1.6.12 SIF Signal Timing 2

AC measurement points : $V_{IH} = 0.7 \times V_{DD50}$, $V_{IL} = 0.3 \times V_{DD50}$
 $V_{OH} = 0.7 \times V_{DD50}$, $V_{OL} = 0.3 \times V_{DD50}$

$V_{DD50} = AV_{DD} = V_{REFH} = 2.2\text{ V to }5.5\text{ V}$
 $V_{SS} = 0\text{ V}, C_L = 50\text{ pF}$
 $T_a = -40\text{ }^\circ\text{C to }+105\text{ }^\circ\text{C}$

Parameter	Symbol	Conditions	Rating			Unit
			MIN	TYP	MAX	
Serial interface 11, at Clock Synchronous, I/O timing 1 (at master (SBT polarity "H")), refer to Figure:1.6.12						
F63	Cycle time	f_{S_CYCLE3}	100			ns
F64	SBT High width	t_{S_HIGH3}	$(t_{S_CYCLE3}/2)-5$			
F65	SBT Low width	t_{S_LOW3}	$(t_{S_CYCLE3}/2)-5$			
F66	SBI/SBO setup time	t_{S_SET3}	10			
F67	SBI/SBO hold time	t_{S_HOLD3}	10			
F68	SBO output delay	t_{S_OPD3}			31	
F69	SBCS setup time	T_{S_CSMST3}			T_{S_CYCLE3}	
Serial interface 11, at Clock Synchronous, I/O timing 2 (at slave (SBT polarity "H")), refer to Figure:1.6.12						
F70	Cycle time	f_{S_CYCLE3}	100			ns
F71	SBT High width	t_{S_HIGH3}	45			
F72	SBT Low width	t_{S_LOW3}	45			
F73	SBI/SBO setup time	t_{S_SET3}	10			
F74	SBI/SBO hold time	t_{S_HOLD3}	10			
F75	SBO output delay	t_{S_OPD3}			31	
F76	SBCS setup time	T_{S_CSSLV3}	$T_{S_CYCLE3}/2$			
Serial interface 11, at Clock Synchronous, I/O timing 3 (at master (SBT polarity "L")), refer to Figure:1.6.12						
F77	Cycle time	f_{S_CYCLE4}	100			ns
F78	SBT High width	t_{S_HIGH4}	$(t_{S_CYCLE4}/2)-5$			
F79	SBT Low width	t_{S_LOW4}	$(t_{S_CYCLE4}/2)-5$			
F80	SBI/SBO setup time	t_{S_SET4}	10			
F81	SBI/SBO hold time	t_{S_HOLD4}	10			
F82	SBO output delay	t_{S_OPD4}			31	
F83	SBCS setup time	T_{S_CSMST4}			T_{S_CYCLE4}	
Serial interface 11, at Clock Synchronous, I/O timing 4 (at slave (SBT polarity "L")), refer to Figure:1.6.12						
F84	Cycle time	f_{S_CYCLE4}	100			ns
F85	SBT High width	t_{S_HIGH4}	45			
F86	SBT Low width	t_{S_LOW4}	45			
F87	SBI/SBO setup time	t_{S_SET4}	10			
F88	SBI/SBO hold time	t_{S_HOLD4}	10			
F89	SBO output delay	t_{S_OPD4}			31	
F90	SBCS setup time	T_{S_CSSLV4}	$T_{S_CYCLE4}/2$			

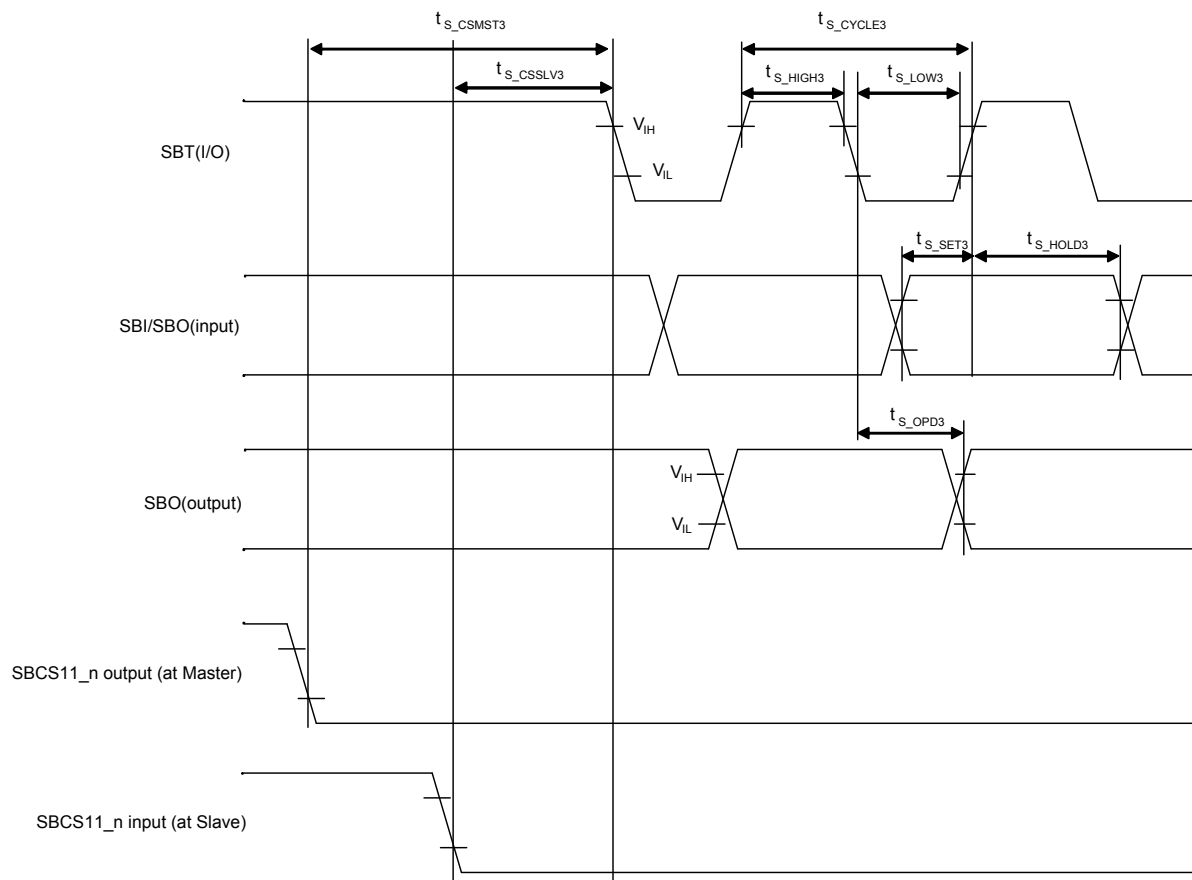

Figure:1.6.13 Serial 11 Signal Timing 1

AC measurement points : $V_{IH} = 0.7 \times V_{DD50}$, $V_{IL} = 0.3 \times V_{DD50}$
 $V_{OH} = 0.7 \times V_{DD50}$, $V_{OL} = 0.3 \times V_{DD50}$

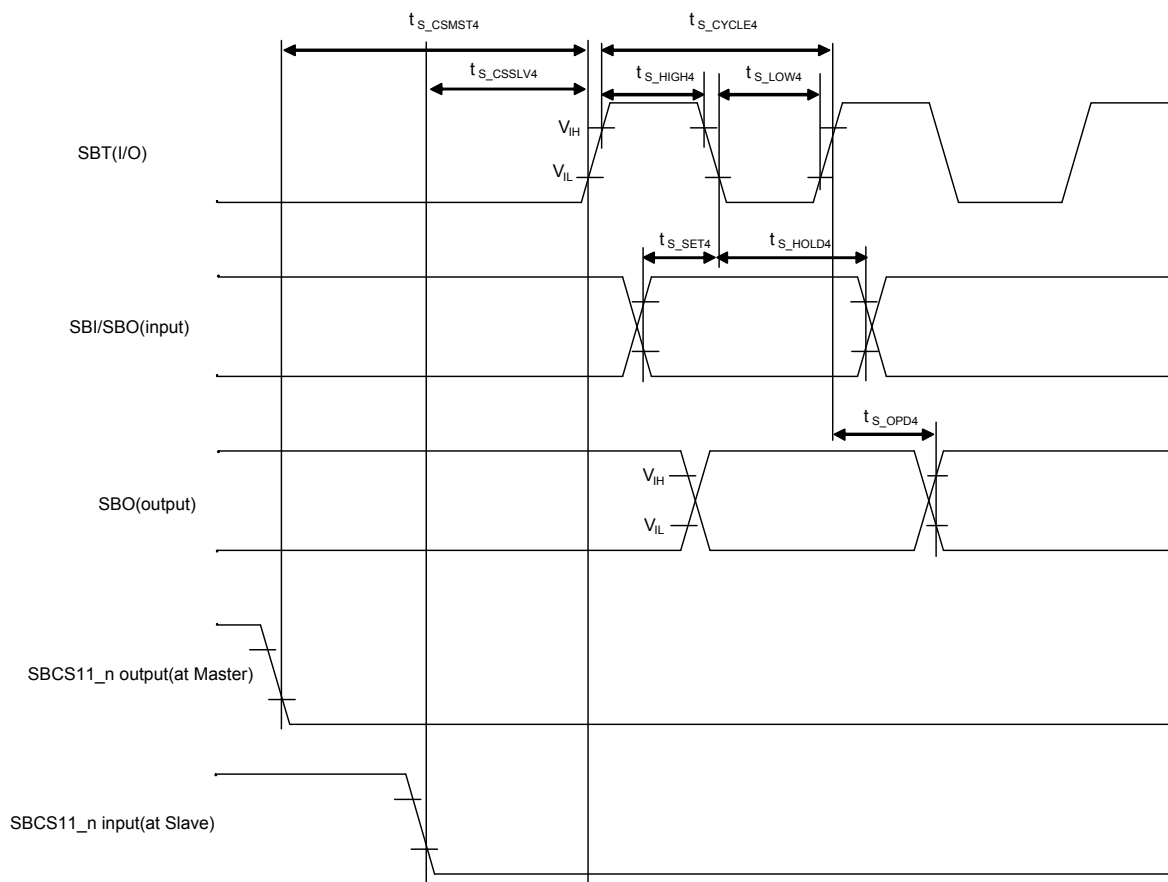

Figure:1.6.14 Serial 11 Signal Timing 2

AC measurement points : $V_{IH} = 0.7 \times V_{DD50}$, $V_{IL} = 0.3 \times V_{DD50}$
 $V_{OH} = 0.7 \times V_{DD50}$, $V_{OL} = 0.3 \times V_{DD50}$



$V_{DD50} = AV_{DD} = V_{REFH} = 2.2\text{ V to }5.5\text{ V}$
 $V_{SS} = 0\text{ V}, C_L = 50\text{ pF}$
 $T_a = -40\text{ }^\circ\text{C to }+105\text{ }^\circ\text{C}$

Parameter	Symbol	Conditions	Rating			Unit
			MIN	TYP	MAX	
Serial interface 0 to 11 (UART)						
F91	Maximum transfer rate	f_{UART}			500	Kbps
CAN						
F92	CAN system clock frequency	f_{CAN}			20	MHz
F93	CAN bit rate	bps			1	Mbps
IEBus						
F94	IEBus system clock frequency	f_{IE}	Communication mode : mode1, 2		20	MHz



G. Internal Flash Memory E/W Characteristics

$V_{SS} = 0\text{ V}$

Parameter		Symbol	Conditions	Rating			Unit
				MIN	TYP	MAX	
G1	Power supply voltage at E/W	V_{DD50EW}		2.7		5.5	V
G2	Ambient temperature at E/W	T_{OPREW}		-40		105	°C
G3	Writing time	t_{WRITE}	Per 64 Bytes		1		ms
G4	Blanking time	Large sector	t_{ERASE1}	Per 1 sector		1	s
G5		Small sector	t_{ERASE2}	Per 1 sector		0.5	

H. Auto Reset Characteristics

$V_{DD50} = AV_{DD} = V_{REFH} = 2.2\text{ V to }5.5\text{ V}$
 $V_{SS} = 0\text{ V}$
 $T_a = -40\text{ }^{\circ}\text{C to }+105\text{ }^{\circ}\text{C}$

Parameter		Symbol	Conditions	Rating			Unit
				MIN	TYP	MAX	
H1	Operating power supply voltage	$V_{DDATRST}$	Auto reset ON	V_{RST}		V_{DD50}	V
H2	Power supply voltage detection level 1	V_{RST1}	At rasing	2.4	2.7	3.0	V
H3	Power supply voltage detection level 2	V_{RST2}	At falling	2.25	2.4	2.55	
H4	Change rate of power supply voltage	$\Delta t/\Delta V$		2.0			ms/V

I. Power Supply Voltage Detection Circuit Characteristics

$V_{DD50} = AV_{DD} = V_{REFH} = 2.2\text{ V to }5.5\text{ V}$
 $V_{SS} = 0\text{ V}$
 $T_a = -40\text{ }^{\circ}\text{C to }+105\text{ }^{\circ}\text{C}$

Parameter		Symbol	Conditions	Rating			Unit
				MIN	TYP	MAX	
I11	Power supply voltage detection level 1	V_{LVI11}	At rising	2.45	2.6	2.75	V
I12		V_{LVI12}	At falling	2.35	2.5	2.65	
I13	Power supply voltage detection level 2	V_{LVI21}	At rising	2.6	2.8	3.0	
I14		V_{LVI22}	At falling	2.5	2.7	2.9	
I15	Power supply voltage detection level 3	V_{LVI31}	At rising	2.8	3.0	3.2	
I16		V_{LVI32}	At falling	2.7	2.9	3.1	
I17	Power supply voltage detection level 4	V_{LVI41}	At rising	3.0	3.2	3.4	
I18		V_{LVI42}	At falling	2.9	3.1	3.3	
I19	Power supply voltage detection level 5	V_{LVI51}	At rising	3.2	3.4	3.6	
I110		V_{LVI52}	At falling	3.1	3.3	3.5	
I111	Power supply voltage detection level 6	V_{LVI61}	At rising	3.4	3.6	3.8	
I112		V_{LVI62}	At falling	3.3	3.5	3.7	
I113	Power supply voltage detection level 7	V_{LVI71}	At rising	3.6	3.8	4.0	
I114		V_{LVI72}	At falling	3.5	3.7	3.9	
I115	Power supply voltage detection level 8	V_{LVI81}	At rising	3.8	4.0	4.2	
I116		V_{LVI82}	At falling	3.7	3.9	4.1	
I117	Minimum pulse width	T_W			15	ms	
I118	Change rate of power supply voltage	$\Delta t/\Delta V$		2.0		ms/V	



J. Internal High-speed Oscillation Circuit Characteristics

$V_{DD50} = AV_{DD} = V_{REFH} = 2.2\text{ V to }5.5\text{ V}$
 $V_{SS} = 0\text{ V}$
 $T_a = -40\text{ }^{\circ}\text{C to }+105\text{ }^{\circ}\text{C}$

Parameter	Symbol	Conditions	Rating			Unit
			MIN	TYP	MAX	
J1 High-speed internal oscillation circuit output frequency	f_{rc}		18	20	22	MHz
J2 Low-speed internal oscillation circuit output frequency	f_{rcx}		27	30	33	kHz

1.7 Package Dimension

- Package of 100 Pin Version Unit: mm

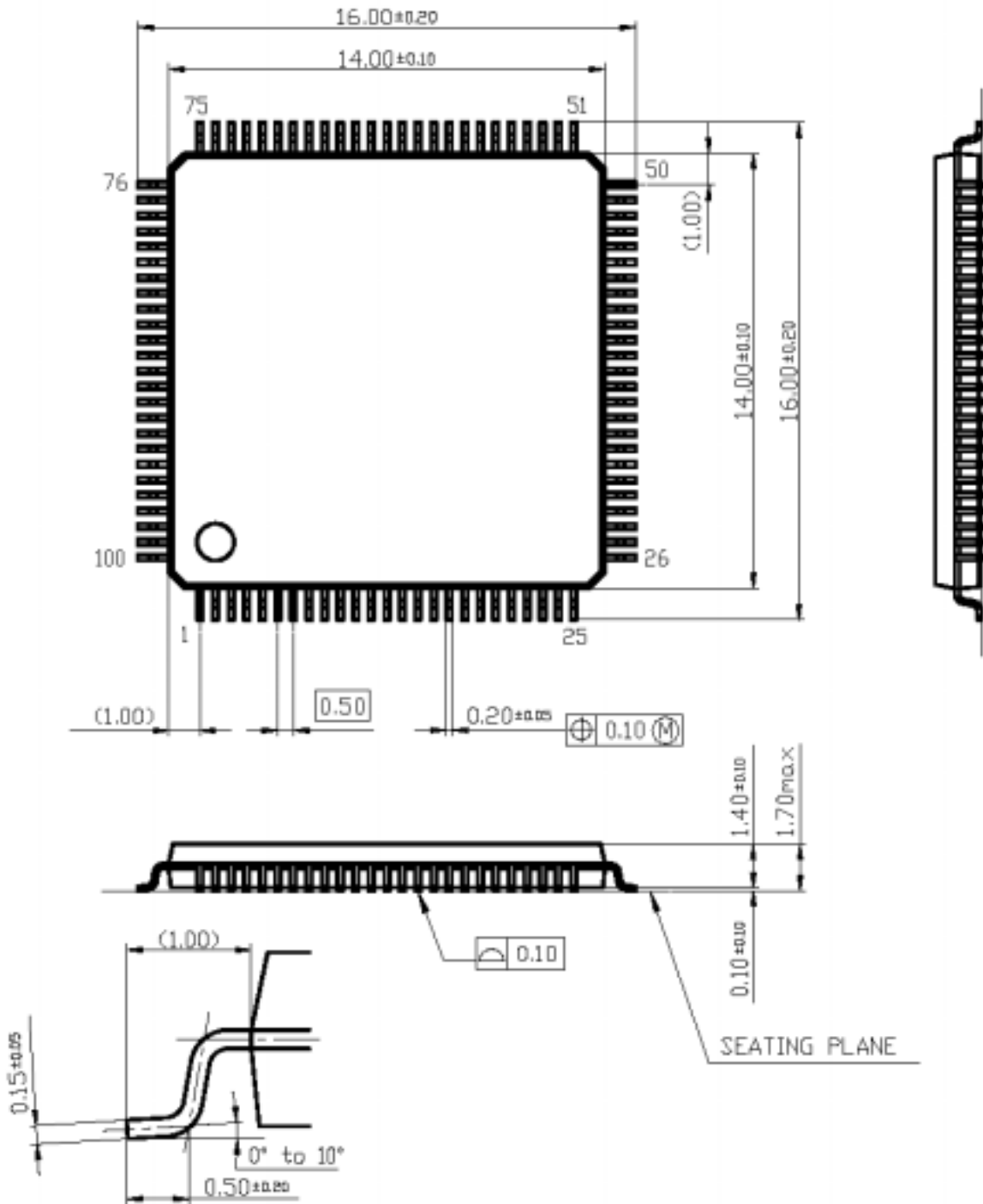

Figure:1.7.1 Package Dimension

■ Package of 128 Pin Version Unit: mm

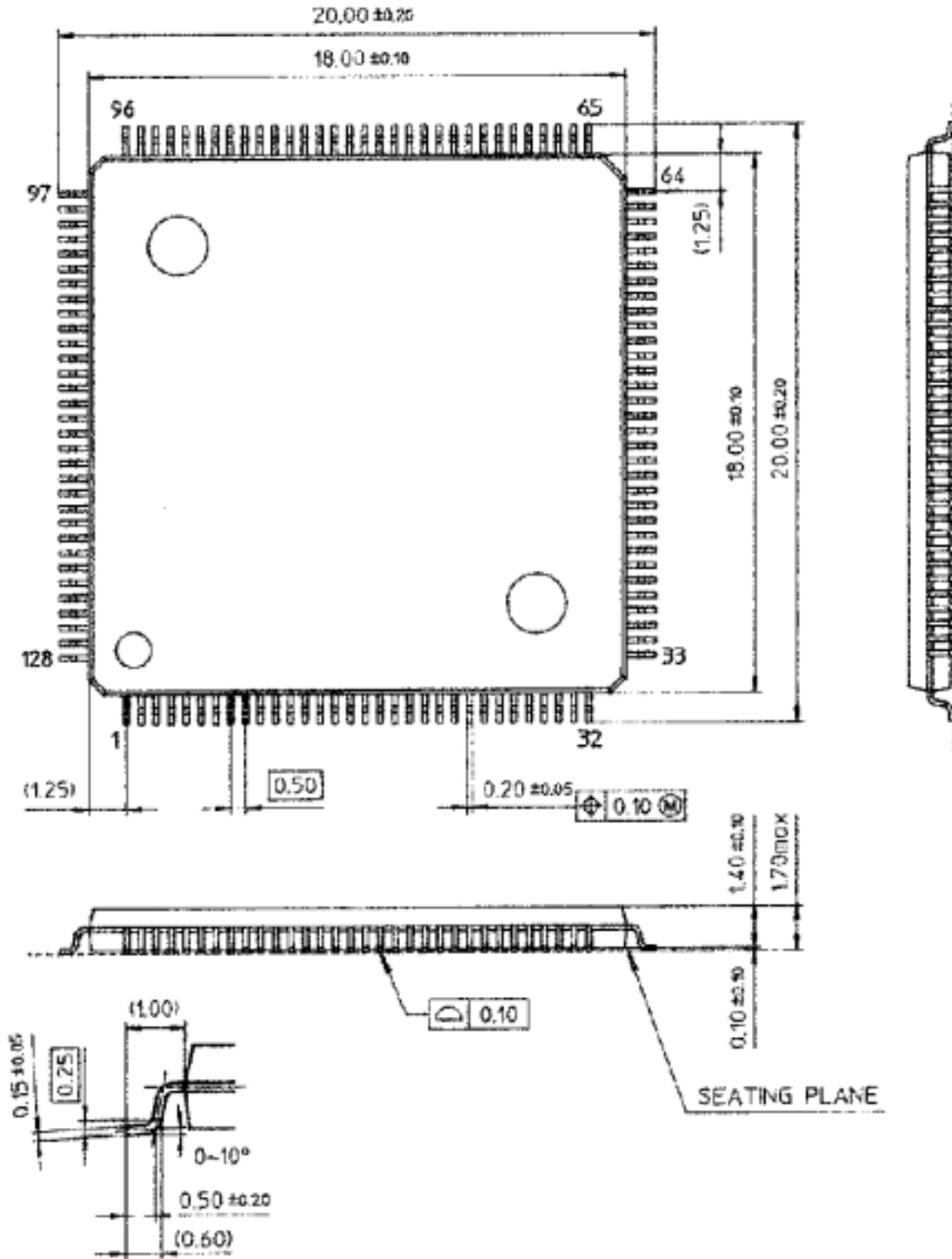

Figure:1.7.2 Package Dimension

■ Package of 176 Pin Version Unit: mm

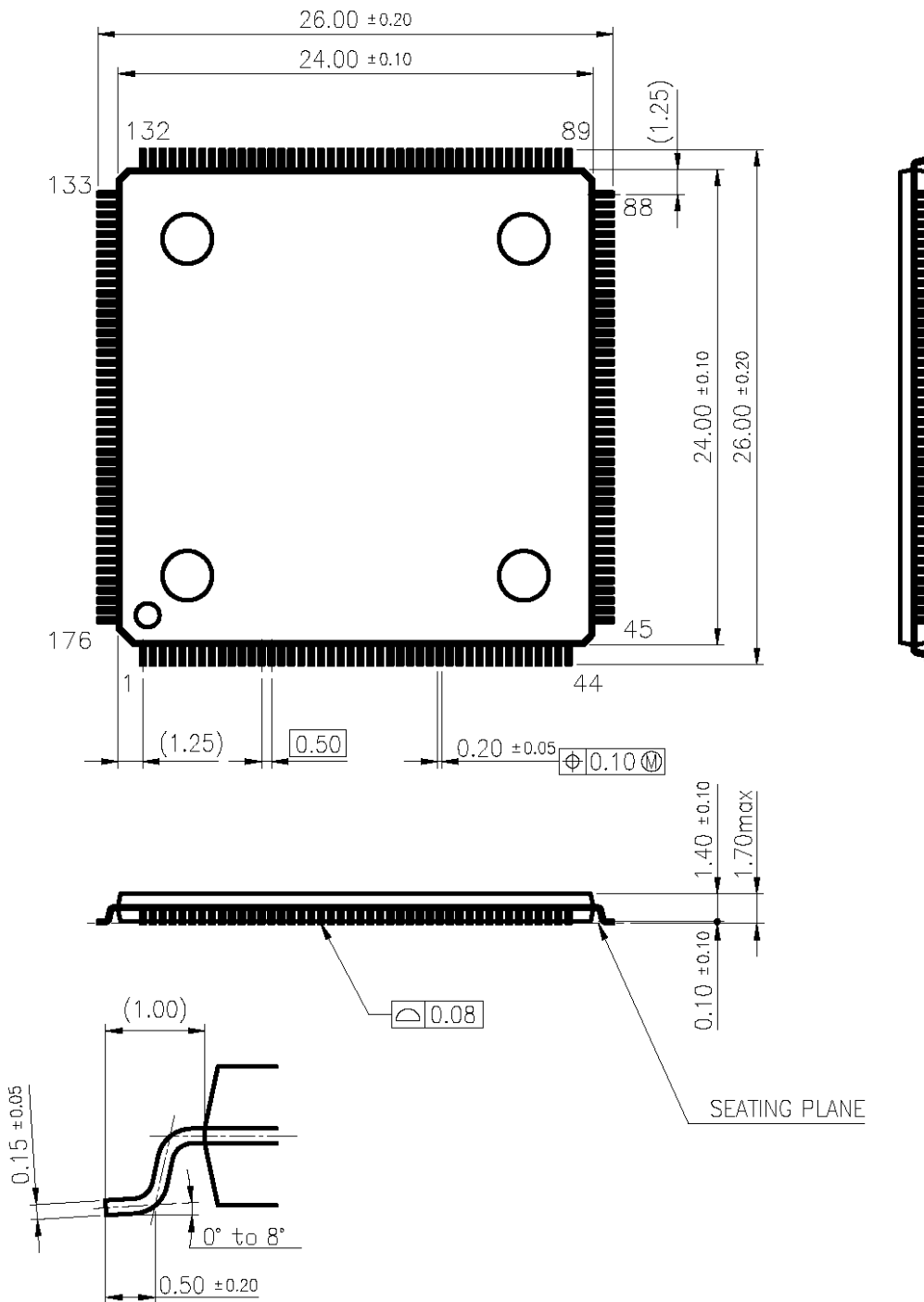

Figure:1.7.4 Package Dimension

Request for your special attention and precautions in using the technical information and semiconductors described in this book

- (1) If any of the products or technical information described in this book is to be exported or provided to non-residents, the laws and regulations of the exporting country, especially, those with regard to security export control, must be observed.
- (2) The technical information described in this book is intended only to show the main characteristics and application circuit examples of the products. No license is granted in and to any intellectual property right or other right owned by Panasonic Corporation or any other company. Therefore, no responsibility is assumed by our company as to the infringement upon any such right owned by any other company which may arise as a result of the use of technical information de-scribed in this book.
- (3) The products described in this book are intended to be used for general applications (such as office equipment, communications equipment, measuring instruments and household appliances), or for specific applications as expressly stated in this book.
Please consult with our sales staff in advance for information on the following applications, moreover please exchange documents separately on terms of use etc.: Special applications (such as for in-vehicle equipment, airplanes, aerospace, automotive equipment, traffic signaling equipment, combustion equipment, medical equipment and safety devices) in which exceptional quality and reliability are required, or if the failure or malfunction of the products may directly jeopardize life or harm the human body.
Unless exchanging documents on terms of use etc. in advance, it is to be understood that our company shall not be held responsible for any damage incurred as a result of or in connection with your using the products described in this book for any special application.
- (4) The products and product specifications described in this book are subject to change without notice for modification and/or improvement. At the final stage of your design, purchasing, or use of the products, therefore, ask for the most up-to-date Product Standards in advance to make sure that the latest specifications satisfy your requirements.
- (5) When designing your equipment, comply with the range of absolute maximum rating and the guaranteed operating conditions (operating power supply voltage and operating environment etc.). Especially, please be careful not to exceed the range of absolute maximum rating on the transient state, such as power-on, power-off and mode-switching. Otherwise, we will not be liable for any defect which may arise later in your equipment.
Even when the products are used within the guaranteed values, take into the consideration of incidence of break down and failure mode, possible to occur to semiconductor products. Measures on the systems such as redundant design, arresting the spread of fire or preventing glitch are recommended in order to prevent physical injury, fire, social damages, for example, by using the products.
- (6) Comply with the instructions for use in order to prevent breakdown and characteristics change due to external factors (ESD, EOS, thermal stress and mechanical stress) at the time of handling, mounting or at customer's process. We do not guarantee quality for disassembled products or the product re-mounted after removing from the mounting board.
When using products for which damp-proof packing is required, satisfy the conditions, such as shelf life and the elapsed time since first opening the packages.
- (7) When reselling products described in this book to other companies without our permission and receiving any claim of request from the resale destination, please understand that customers will bear the burden.
- (8) This book may be not reprinted or reproduced whether wholly or partially, without the prior written permission of our company.