

BTPA Series

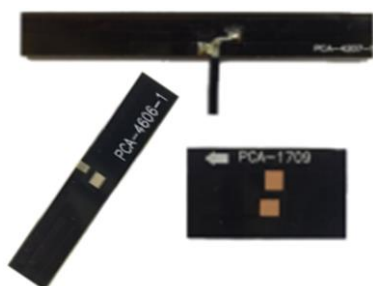

Features

- Small size low-profile, low cost and lightweight type
- Wide bandwidth and Omni-directional
- Supported with Dip-type, SMD, and Co-axial cable connecting
- Customized

Applications

- Bluetooth, Wireless Router, Set Top Box and Home digital
- ISM band, Lora, Sigfox, LTE, NB-IOT, GPS, WiFi and Car use.

Product Identification

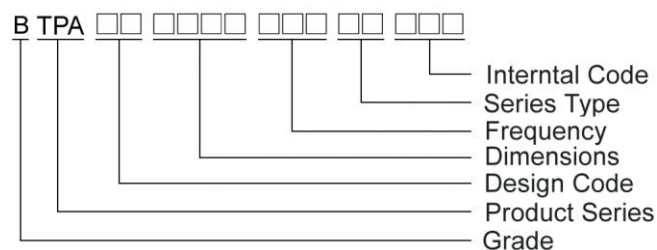

Shapes and Dimensions

FIG 1

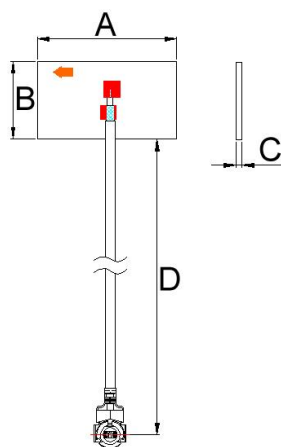

FIG 2

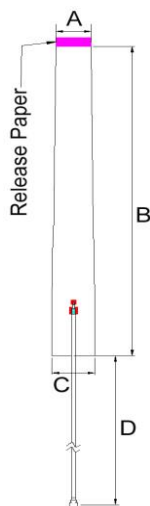
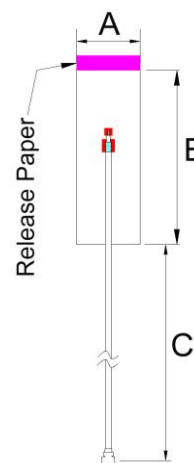

FIG 3



Dimensions in mm

TYPE	FIG	A	B	C	D
BTPA0017095G0C1B19	1	17.5	9.8	0.8	110±5
BTPA0010136G0C1A01	2	10.6	130	13	100±5
BTPA0012353G8C1A01	3	12.5	35	100±5	-
BTPA0012353G9C1A01	3	12.5	35	100±5	-

Shapes and Dimensions

FIG 4

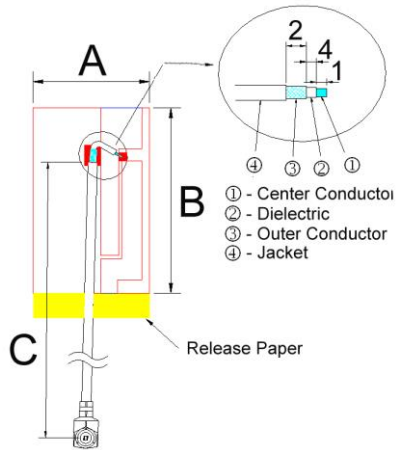

FIG 5

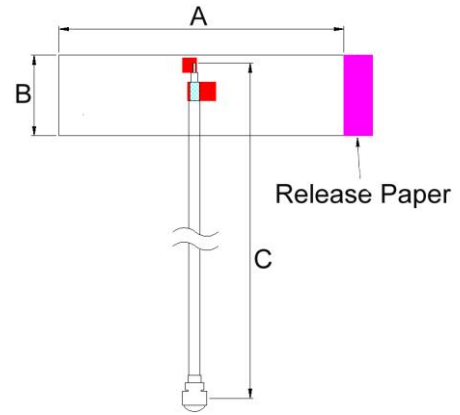

FIG 6

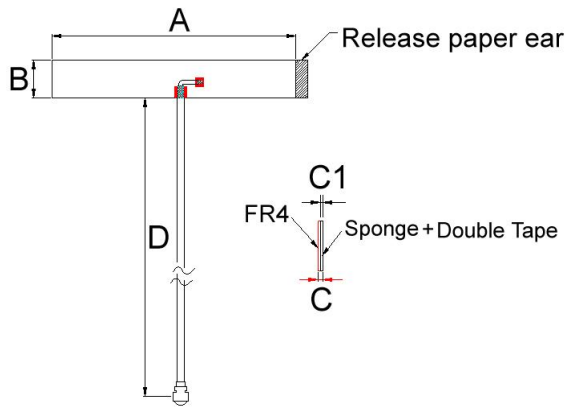
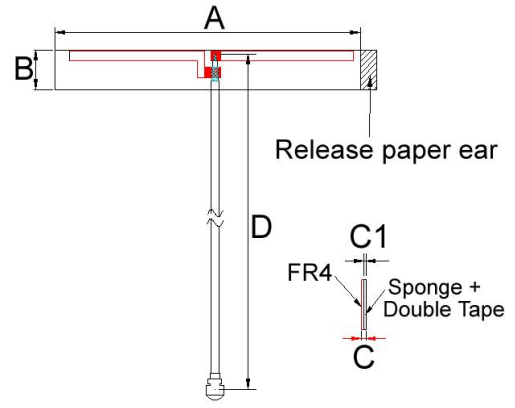

FIG 7



Dimensions in mm

TYPE	FIG	A	B	C	D
BTPA00221425GC1A09	4	14.3	22.7	143±3	-
BTPA0030082G4C1A04	5	30	8.5	220±2	-
BTPA00420725GC1A04	6	42	6.5	1.8±0.5	1.0±0.3
BTPA0046062G4C1B03	7	46.5	6	2.1±0.5	1.3±0.3

PCB Antenna BTPA Series

Electrical Characteristics

Part Number	Frequency Range (GHz)	Impedance (Ω)	Return Loss dB(Max)	VSWR (Max)	Radiation	Peak Gain (dB)	Polarization	Admitted Power (W)
BTPA0017095G0C1B19	5.15~5.85	50	-10	-	Omni-directional	2.67	Linear Vertical	1
BTPA0010136G0C1A01	0.617~0.96	50	-	4	Omni-directional	0.59	Linear Vertical	1
	1.71~2.17					3.74		
	2.3~2.7					3.51		
	3.3~3.8					3.7		
	4.4~5					4		
	5.15~5.85					4.87		
BTPA0012353G8C1A01	3.3~3.8	50	-10	-	Omni-directional	2.69	Linear Vertical	1
BTPA0012353G9C1A01	3.3~3.9	50	-7	-	Omni-directional	4.89	Linear Vertical	1
BTPA00221425GC1A09	2.4	50	-10	2	Omni-directional	2.78	Linear Vertical	1
	5					2.53		
BTPA0030082G4C1A04	2.4~2.5	50	-10	-	Omni-directional	3.37	Linear Vertical	1
BTPA00420725GC1A04	2.4	50	-10	-	Omni-directional	2.82	Linear Vertical	1
	5					3.12		
BTPA0046062G4C1B03	2.4~2.5	50	-10	2	Omni-directional	3	Linear Vertical	1
BTPA0052116G0C1A01	2.4~2.5	50	-10		Omni-directional	5.65	Linear Vertical	1
	5.15~5.85					5.94		
	5.925~6.325					6.42		
	6.35~6.75					6.87		
	6.775~7.125					5.42		

Physical Properties

Part Number	Antenna Material(Body)	Cable	Color	Connector	Double Tape	Sponge
BTPA0017095G0C1B19	FR4 Black paint OSP board	RF-113	Black	IPEX Compatible	-	-
BTPA0010136G0C1A01	FR4 Black paint OSP board	RF-113	Black	IPEX Compatible	3M 9448	-
BTPA0012353G8C1A01	FR4 Black paint OSP board	RF-113	Black	IPEX Compatible	3M 9448	-
BTPA0012353G9C1A01	FR4 Black paint OSP board	RF-113	Black	IPEX Compatible	3M 9448	-
BTPA00221425GC1A09	FR4 Black paint sneeze	RF-113	Gray	IPEX	G9000	-
BTPA0030082G4C1A04	FR4 Black paint OSP board	RF-113	Gray	IPEX Compatible	G9000	-
BTPA00420725GC1A04	FR4 Black paint OSP board	RF-113	Black	IPEX Compatible	3M 9448	EVA
BTPA0046062G4C1B03	FR4 Black paint sneeze	RF-113	Gray	IPEX	3M 9448	EVA
BTPA0052116G0C1A01	FR4 Black paint OSP board	RF-113	Black	IPEX Compatible	3M 9448	-

- Operating temperature range - 20°C ~ +65°C
- Storage temperature range - 30°C ~ +75°C

Please be sure to request approval specifications that provide further details of the products. Kindly note that the content of these specifications are subject to change or may be discontinued without prior notice. This product may not be designed/used in medical or high risk applications without Chilisin approval. Please contact our sales department before ordering.

BTPA0017095G0C1B19

Experimental Setup

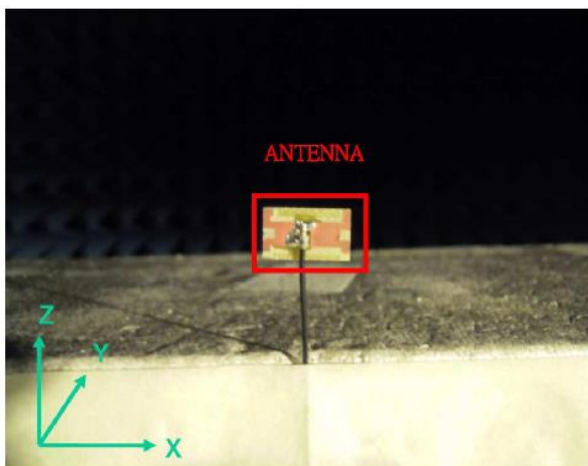

Return Loss S11

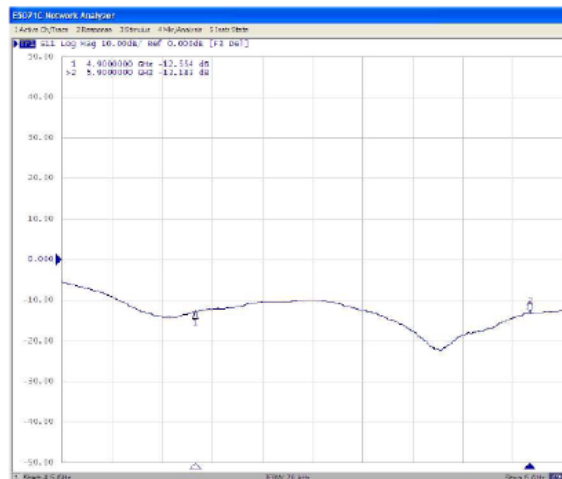

Frequency(MHz): 5150~5850. Pattern Field: X-Y plane

Frequency(MHz): 5150~5850. Pattern Field: Y-Z plane

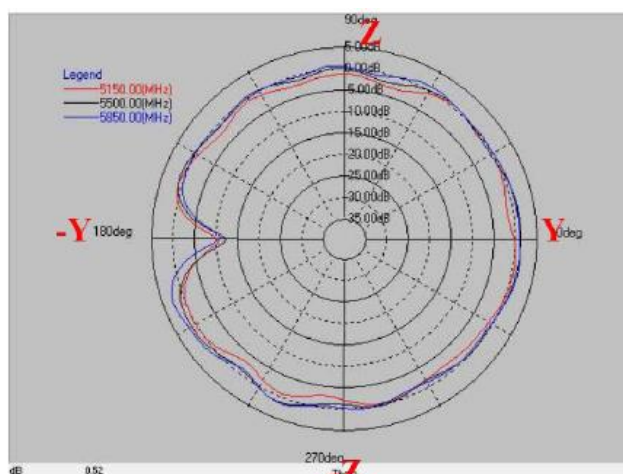
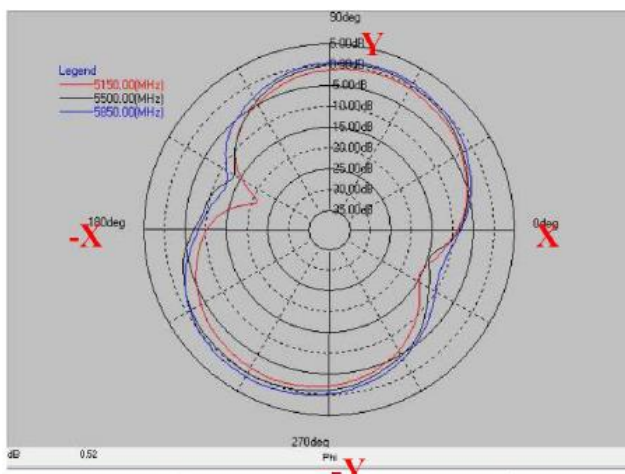

Layer	Max value	Min value	Average
5150(MHz)	-0.57 dB	-21.11 dB	-4.18 dB
5500(MHz)	0.57 Db	-14.73 dB	-2.89 dB
5850(MHz)	1.05 dB	-12.68 dB	-2.18 dB

Layer	Max value	Min value	Average
5150(MHz)	0.87 dB	-10.45 dB	-1.27 dB
5500(MHz)	1.33 dB	-12.56 dB	-0.30 dB
5850(MHz)	2.67 dB	-11.11 dB	0.01 dB

Frequency(MHz): 5150~5850. Pattern Field: X-Z plane

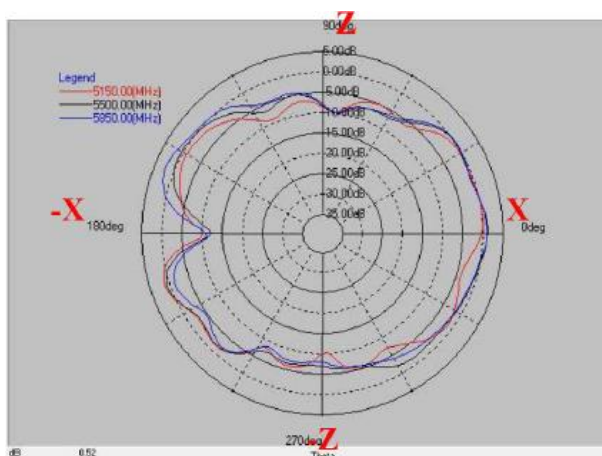

Layer	Max value	Min value	Average
5150(MHz)	1.30 dB	-10.45 dB	-3.31 dB
5500(MHz)	1.25 dB	-12.56 dB	-2.53 dB
5850(MHz)	2.25 dB	-11.19 dB	-2.43 dB

Please be sure to request approval specifications that provide further details of the products. Kindly note that the content of these specifications are subject to change or may be discontinued without prior notice. This product may not be designed/used in medical or high risk applications without Chilisin approval. Please contact our sales department before ordering.

BTPA0010136G0C1A1

Return Loss

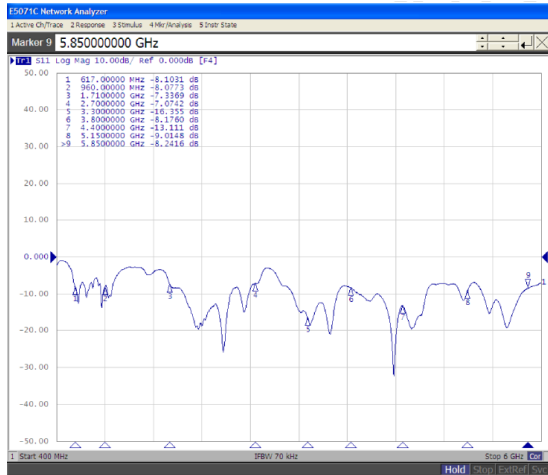

VSWR

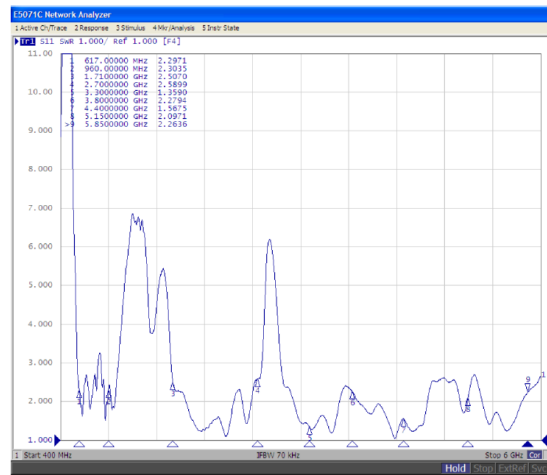

Frequency(MHz) : 617~960. Pattern Field : Z-X plane

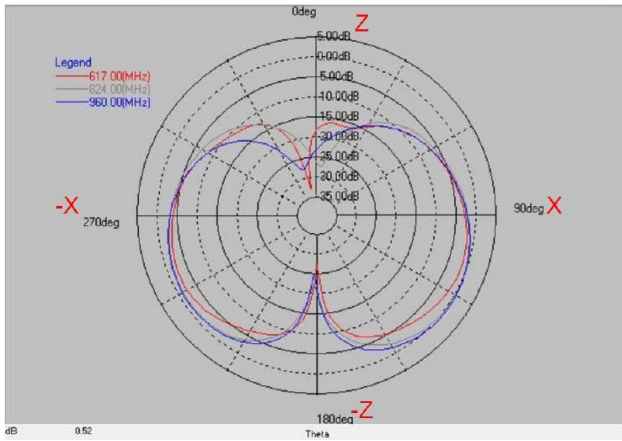

Layer	Max value	Min value	Average
617(MHz)	-1.39 dB	-33.33 dB	-5.85 dB
824(MHz)	0.22 dB	-27.68 dB	-4.37 dB
960(MHz)	0.42 dB	-28.14 dB	-4.28 dB

Frequency(MHz) : 617~960. Pattern Field : Z-Y plane

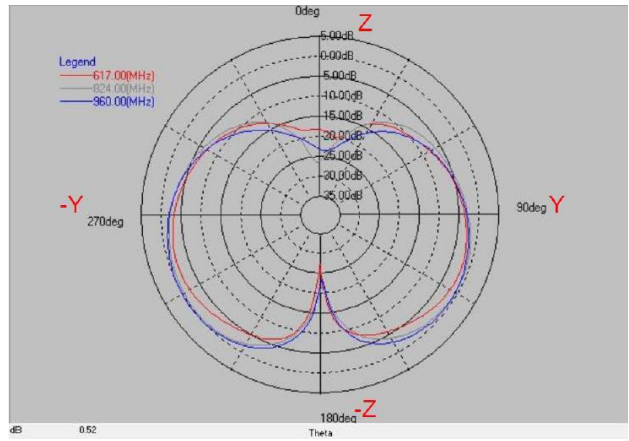

Layer	Max value	Min value	Average
617(MHz)	-1.80 dB	-27.56 dB	-5.79 dB
824(MHz)	-0.32 dB	-27.04 dB	-4.34 dB
960(MHz)	0.09 dB	-23.93 dB	-4.21 dB

Frequency(MHz) : 617~960. Pattern Field : X-Y plane

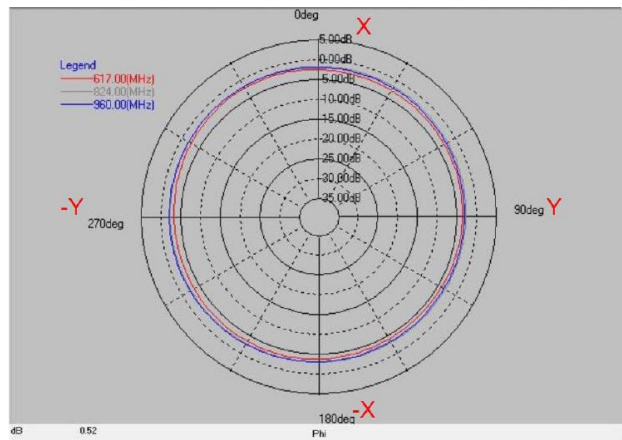

Layer	Max value	Min value	Average
617(MHz)	-2.37 dB	-4.29 dB	-3.32 dB
824(MHz)	-1.85 dB	-3.26 dB	-2.46 dB
960(MHz)	-1.93 dB	-3.48 dB	-2.58 dB

Frequency(MHz) : 1710~2170. Pattern Field : Z-X plane

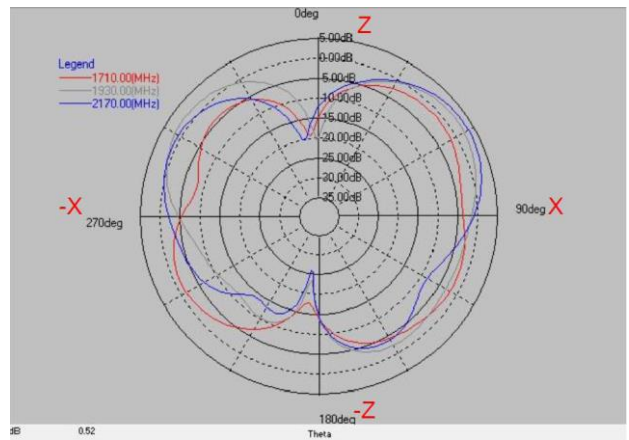

Layer	Max value	Min value	Average
1710(MHz)	-1.27 dB	-19.63 dB	-4.33 dB
1930(MHz)	2.35 dB	-23.75 dB	-2.26 dB
2170(MHz)	3.54 dB	-26.16 dB	-2.41 dB

Please be sure to request approval specifications that provide further details of the products. Kindly note that the content of these specifications are subject to change or may be discontinued without prior notice. This product may not be designed/used in medical or high risk applications without Chilisin approval. Please contact our sales department before ordering.

PCB Antenna BTPA Series

Frequency(MHz) : 1710~2170. Pattern Field : Z-Y plane

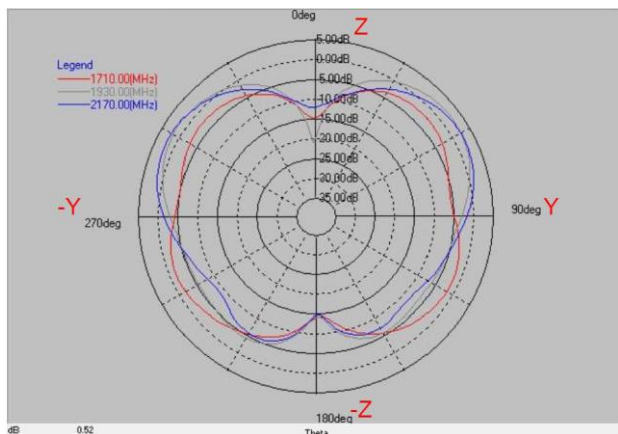

Layer	Max value	Min value	Average
1710(MHz)	-1.65 dB	-15.05 dB	-4.37 dB
1930(MHz)	2.59 dB	-21.40 dB	-2.33 dB
2170(MHz)	3.43 dB	-15.04 dB	-2.50 dB

Frequency(MHz) : 1710~2170. Pattern Field : X-Y plane

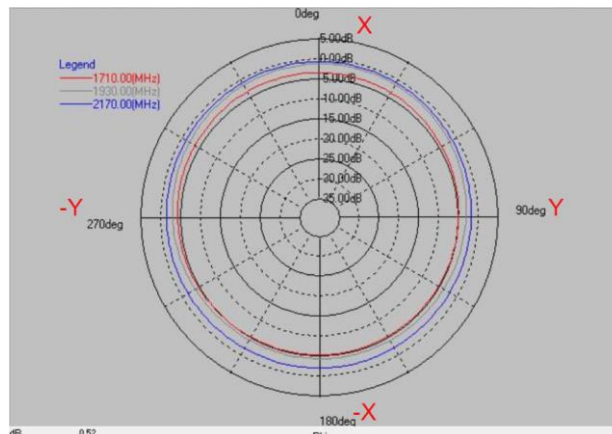

Layer	Max value	Min value	Average
1710(MHz)	-3.57 dB	-5.49 dB	-4.49 dB
1930(MHz)	-1.45 dB	-4.54 dB	-2.85 dB
2170(MHz)	-0.91 dB	-2.21 dB	-1.53 dB

Frequency(MHz) : 2300~2700. Pattern Field : Z-X plane

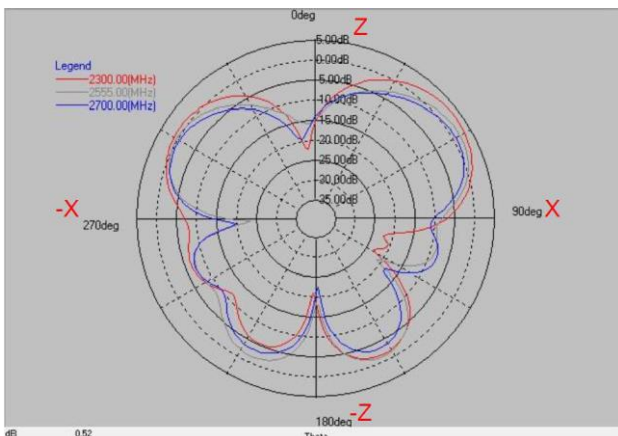

Layer	Max value	Min value	Average
2300(MHz)	3.48 dB	-23.31 dB	-2.83 dB
2555(MHz)	2.02 dB	-23.64 dB	-3.80 dB
2700(MHz)	0.79 dB	-22.71 dB	-4.96 dB

Frequency(MHz) : 2300~2700. Pattern Field : Z-Y plane

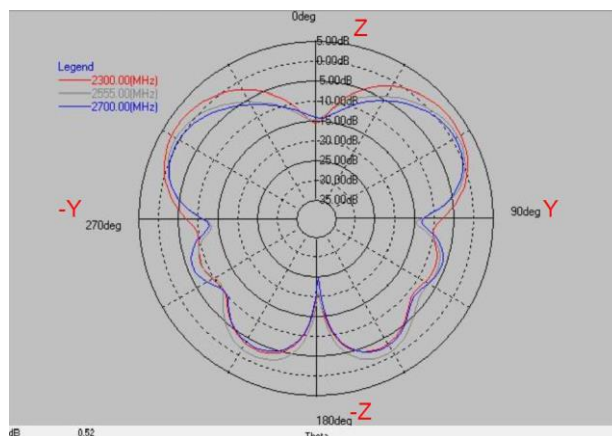

Layer	Max value	Min value	Average
2300(MHz)	2.66 dB	-20.71 dB	-2.81 dB
2555(MHz)	1.64 dB	-21.35 dB	-3.69 dB
2700(MHz)	0.80 dB	-25.15 dB	-4.63 dB

Frequency(MHz) : 2300~2700. Pattern Field : X-Y plane

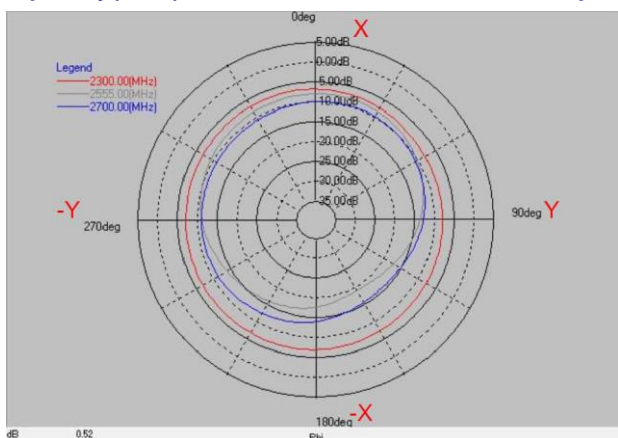

Layer	Max value	Min value	Average
2300(MHz)	-6.96 dB	-8.08 dB	-7.33 dB
2555(MHz)	-8.25 dB	-19.35 dB	-11.43 dB
2700(MHz)	-10.03 dB	-16.08 dB	-11.84 dB

Frequency(MHz) : 3300~3800. Pattern Field : Z-X plane

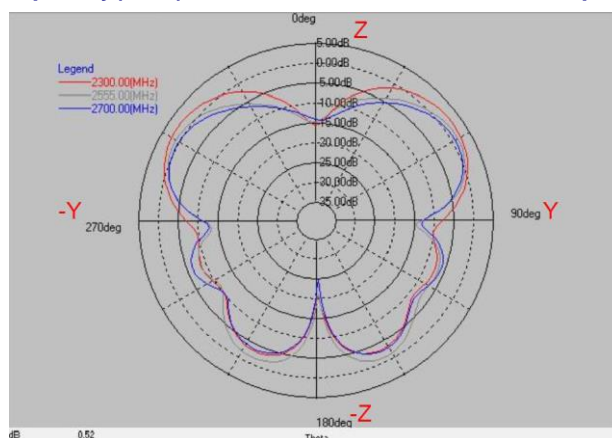

Layer	Max value	Min value	Average
3300(MHz)	3.07 dB	-20.14 dB	-2.57 dB
3550(MHz)	3.26 dB	-24.17 dB	-2.51 dB
3800(MHz)	3.43 dB	-22.01 dB	-2.77 dB

Please be sure to request approval specifications that provide further details of the products. Kindly note that the content of these specifications are subject to change or may be discontinued without prior notice. This product may not be designed/used in medical or high risk applications without Chilisin approval. Please contact our sales department before ordering.

PCB Antenna BTPA Series

Frequency(MHz) : 3300~3800. Pattern Field : Z-Y plane

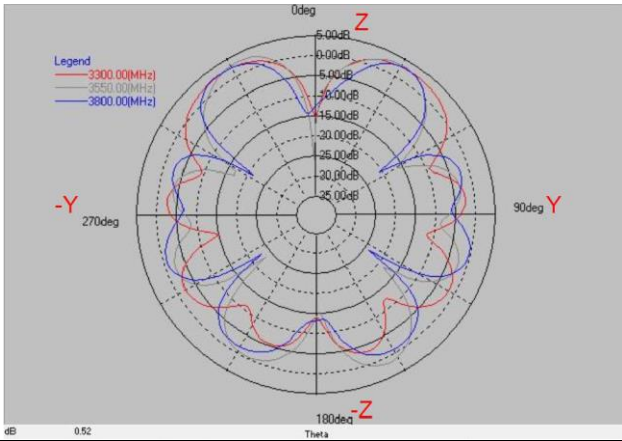

Layer	Max value	Min value	Average
3300(MHz)	2.85 dB	-15.41 dB	-2.31 dB
3550(MHz)	3.17 dB	-26.31 dB	-2.40 dB
3800(MHz)	3.01 dB	-24.18 dB	-2.64 dB

Frequency(MHz) : 3300~3800. Pattern Field : X-Y plane

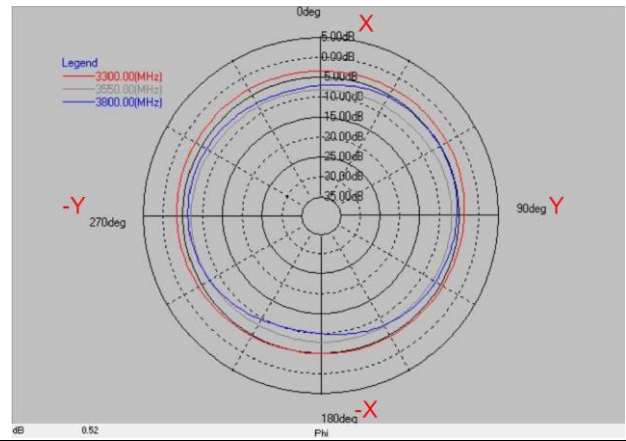

Layer	Max value	Min value	Average
3300(MHz)	-3.08 dB	-5.14 dB	-3.90 dB
3550(MHz)	-6.85 dB	-8.46 dB	-7.70 dB
3800(MHz)	-5.16 dB	-10.45 dB	-6.92 dB

Frequency(MHz) : 4400~5000. Pattern Field : Z-X plane

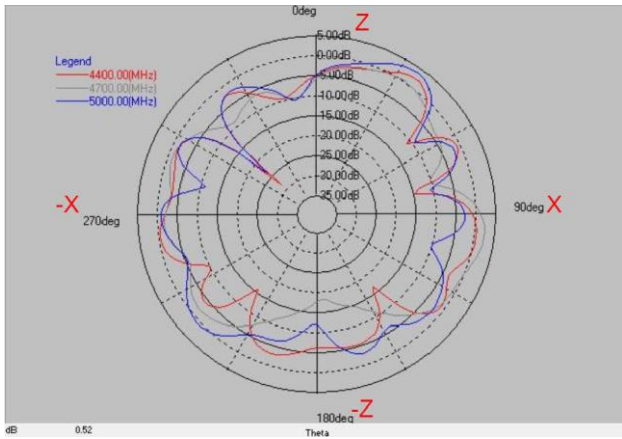

Layer	Max value	Min value	Average
4400(MHz)	2.11 dB	-28.32 dB	-3.84 dB
4700(MHz)	2.51 dB	-18.54 dB	-3.40 dB
5000(MHz)	3.59 dB	-23.84 dB	-3.01 dB

Frequency(MHz) : 4400~5000. Pattern Field : Z-Y plane

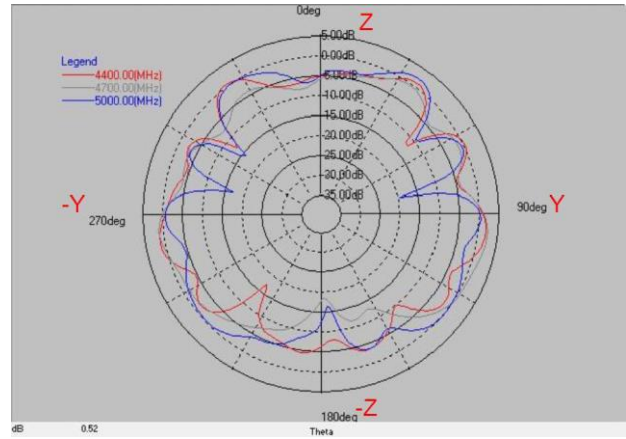

Layer	Max value	Min value	Average
4400(MHz)	1.97 dB	-17.60 dB	-2.70 dB
4700(MHz)	2.50 dB	-18.71 dB	-2.84 dB
5000(MHz)	2.13 dB	-19.53 dB	-2.61 dB

Frequency(MHz) : 4400~5000. Pattern Field : X-Y plane

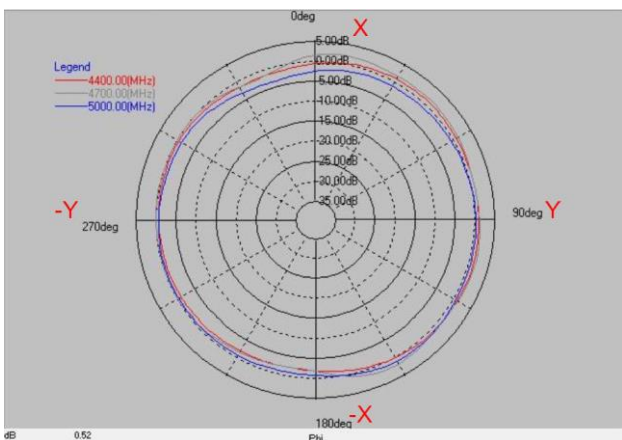

Layer	Max value	Min value	Average
4400(MHz)	1.22 dB	-2.37 dB	-0.27 dB
4700(MHz)	1.93 dB	-2.41 dB	0.43 dB
5000(MHz)	1.00 dB	-3.76 dB	-0.68 dB

Frequency(MHz) : 5150~5850. Pattern Field : Z-X plane

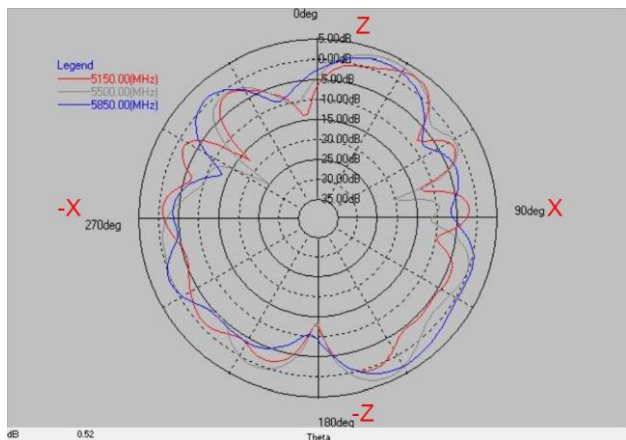

Layer	Max value	Min value	Average
5150(MHz)	3.06 dB	-17.47 dB	-2.82 dB
5500(MHz)	3.71 dB	-25.19 dB	-1.36 dB
5850(MHz)	2.94 dB	-13.40 dB	-1.46 dB

Please be sure to request approval specifications that provide further details of the products. Kindly note that the content of these specifications are subject to change or may be discontinued without prior notice. This product may not be designed/used in medical or high risk applications without Chilisin approval. Please contact our sales department before ordering.

PCB Antenna BTPA Series

Frequency(MHz) : 5150~5850. Pattern Field : Z-Y plane

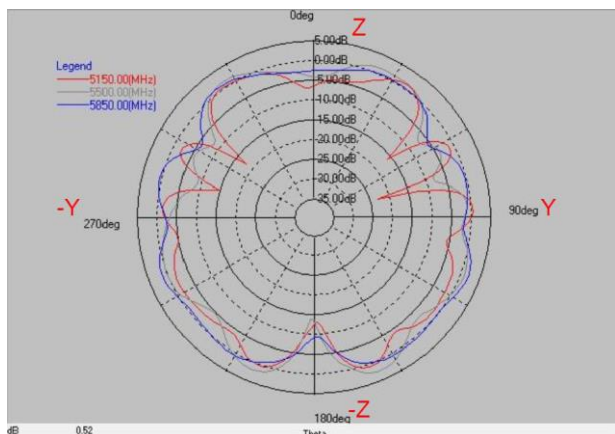

Layer	Max value	Min value	Average
5150(MHz)	1.20 dB	-23.10 dB	-2.62 dB
5500(MHz)	2.46 dB	-13.93 dB	-1.33 dB
5850MHz)	2.03 dB	-9.55 dB	-0.79 dB

Frequency(MHz) : 5150~5850. Pattern Field : X-Y plane

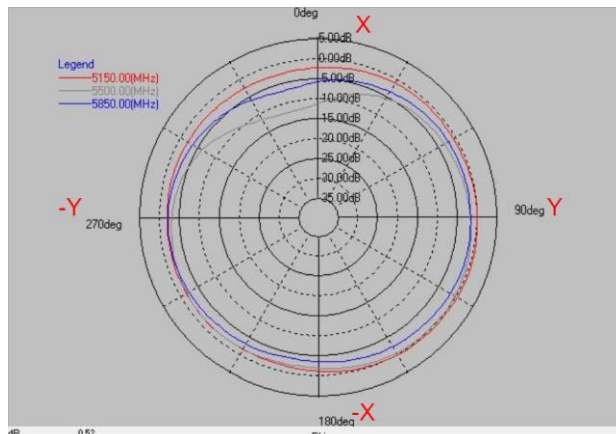

Layer	Max value	Min value	Average
5150(MHz)	0.43 dB	-2.78 dB	-1.15 dB
5500(MHz)	-0.23 dB	-12.82 dB	-3.00 dB
5850MHz)	-1.38 dB	-7.14 dB	-2.99 dB

Frequency(MHz) : 5150~5850. Pattern Field : Z-Y plane

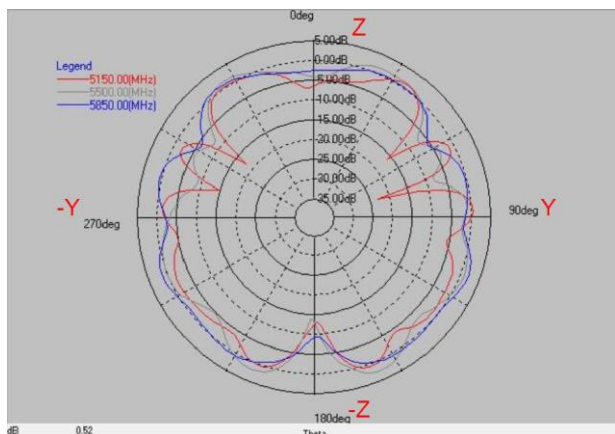

Layer	Max value	Min value	Average
5150(MHz)	1.20 dB	-23.10 dB	-2.62 dB
5500(MHz)	2.46 dB	-13.93 dB	-1.33 dB
5850MHz)	2.03 dB	-9.55 dB	-0.79 dB

Frequency(MHz) : 5150~5850. Pattern Field : X-Y plane

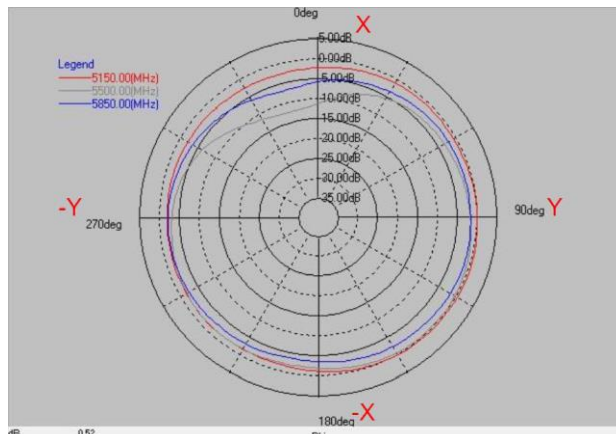

Layer	Max value	Min value	Average
5150(MHz)	0.43 dB	-2.78 dB	-1.15 dB
5500(MHz)	-0.23 dB	-12.82 dB	-3.00 dB
5850MHz)	-1.38 dB	-7.14 dB	-2.99 dB

3D Peak Gain

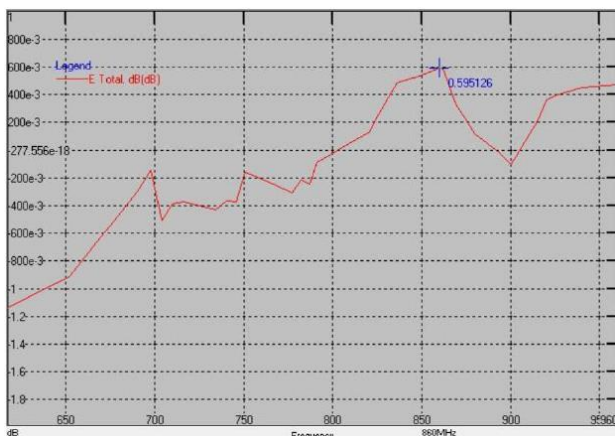

3D Efficiency

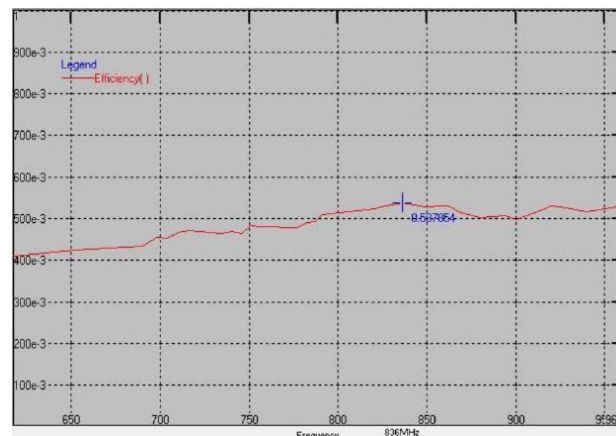

Please be sure to request approval specifications that provide further details of the products. Kindly note that the content of these specifications are subject to change or may be discontinued without prior notice. This product may not be designed/used in medical or high risk applications without Chilisin approval. Please contact our sales department before ordering.

PCB Antenna BTPA Series

3D Peak Gain

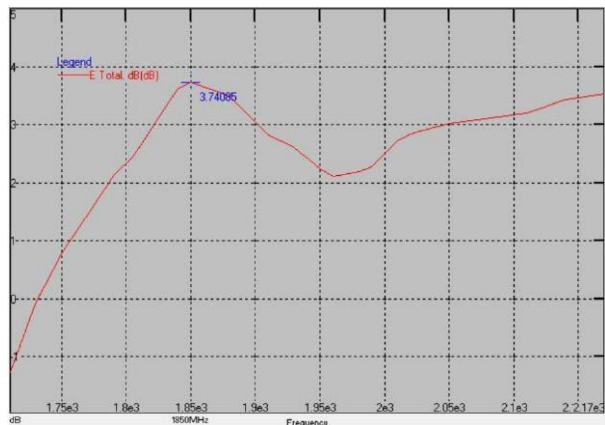

3D Efficiency

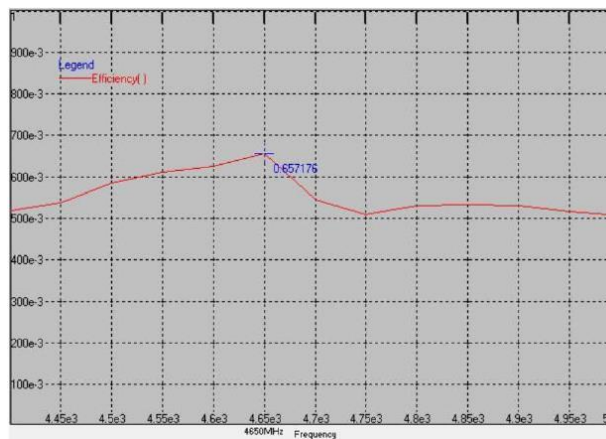
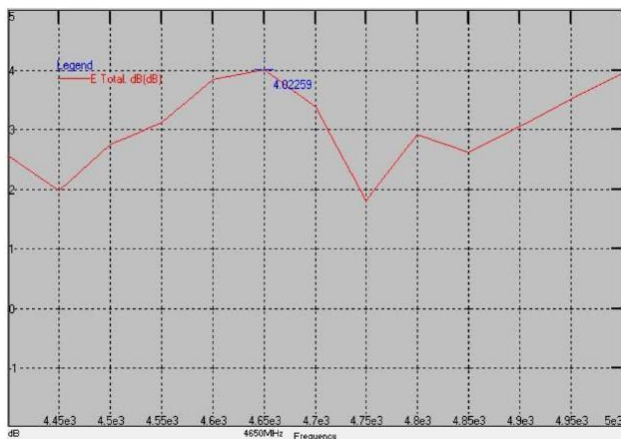
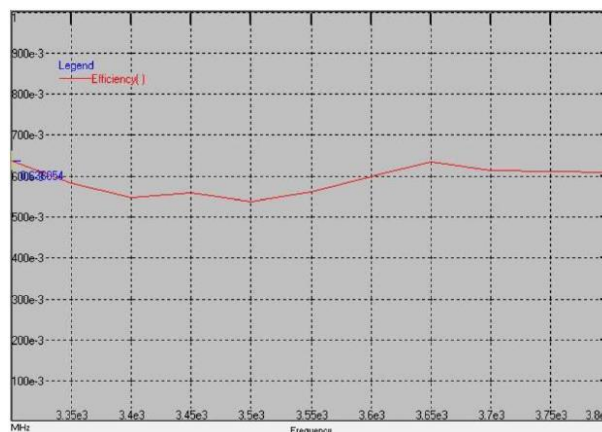
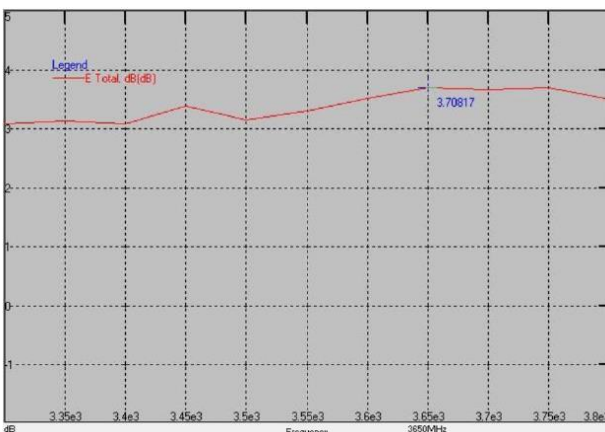
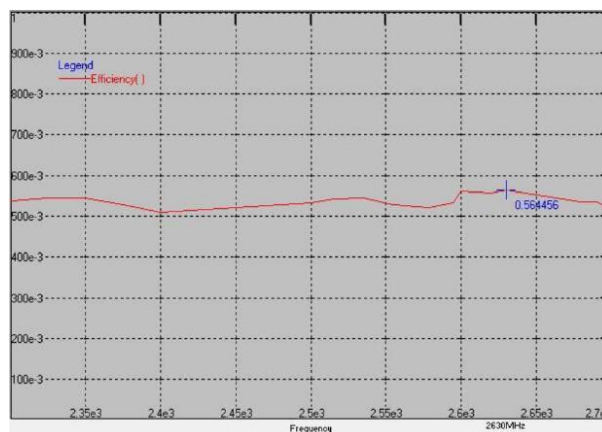
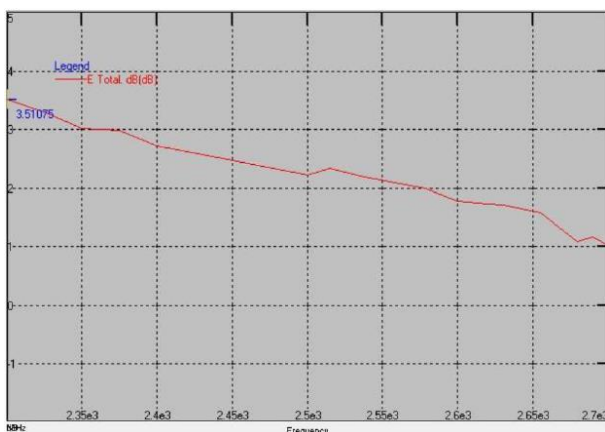
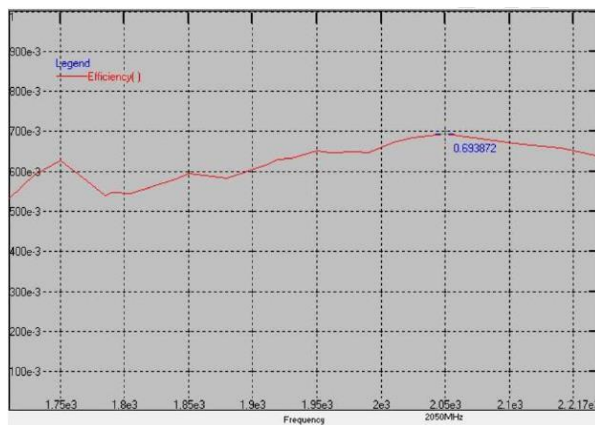

Please be sure to request approval specifications that provide further details of the products. Kindly note that the content of these specifications are subject to change or may be discontinued without prior notice. This product may not be designed/used in medical or high risk applications without Chilisin approval. Please contact our sales department before ordering.



PCB Antenna BTPA Series

3D Peak Gain

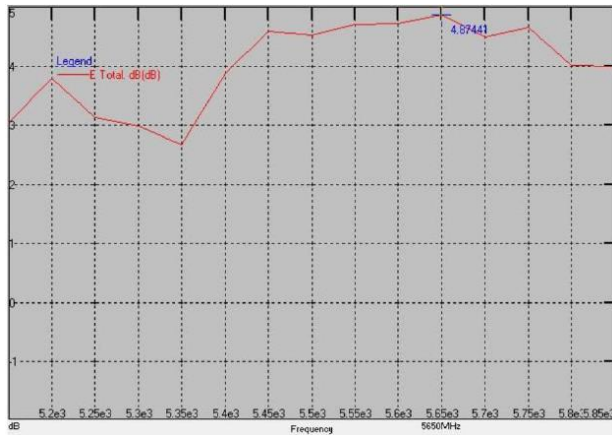

3D Efficiency

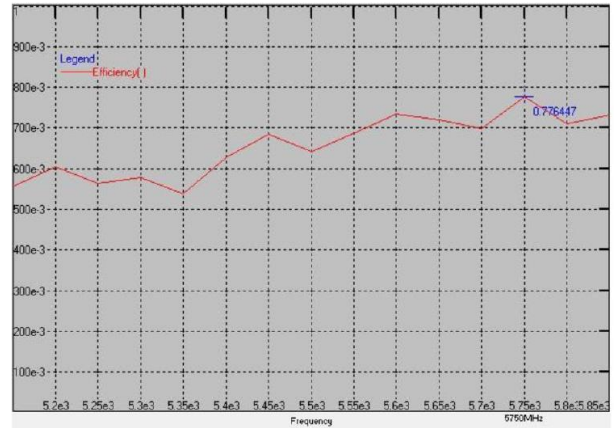

Frequency (MHz)	Peak Gain (dBi)	Efficiency (%)	Frequency (MHz)	Peak Gain (dBi)	Efficiency (%)
617	-1.14	41	2620	1.73	56
690	-0.30	43	2630	1.71	56
710	-0.39	45	2655	1.59	55
716	-0.38	47	2680	1.08	54
740	-0.36	47	2690	1.17	53
756	-0.19	47	2700	1.03	52
791	-0.09	48	3300	3.09	64
824	0.22	51	3350	3.14	58
836	0.48	53	3400	3.09	55
869	0.34	54	3450	3.39	56
880	0.12	51	3500	3.15	54
894	-0.02	50	3550	3.30	56
915	0.21	51	3600	3.52	60
920	0.36	50	3650	3.71	63
925	0.40	52	3700	3.67	61
940	0.45	53	3750	3.70	61
960	0.47	53	3800	3.50	61
1710	-1.27	53	4400	2.56	52
1750	0.79	63	4450	1.99	54
1785	1.95	54	4500	2.75	59
1805	2.44	55	4550	3.12	61
1840	3.62	58	4600	3.86	63
1880	3.50	58	4650	4.02	66
1910	2.82	62	4700	3.39	54
1930	2.60	63	4750	1.81	51
1950	2.25	65	4800	2.92	53
1980	2.20	65	4850	2.62	53
1990	2.28	65	4900	3.06	53
2010	2.73	67	4950	3.51	52
2025	2.87	69	5000	3.96	51
2050	3.03	69	5150	3.06	56
2110	3.21	67	5200	3.81	60
2140	3.43	66	5250	3.14	56
2170	3.54	64	5300	3.00	58
2300	3.51	54	5350	2.67	54
2325	3.30	55	5400	3.88	63
2350	3.03	54	5450	4.60	69
2375	2.99	53	5500	4.52	64
2400	2.72	51	5550	4.71	69
2500	2.23	53	5600	4.73	73
2515	2.34	54	5650	4.87	72
2535	2.21	54	5700	4.49	70
2555	2.12	53	5750	4.66	78
2579	1.99	52	5800	4.01	71
2595	1.83	53	5850	3.99	73

Please be sure to request approval specifications that provide further details of the products. Kindly note that the content of these specifications are subject to change or may be discontinued without prior notice. This product may not be designed/used in medical or high risk applications without Chilisin approval. Please contact our sales department before ordering.

BTPA0012353G8C1A01

Return Loss S11

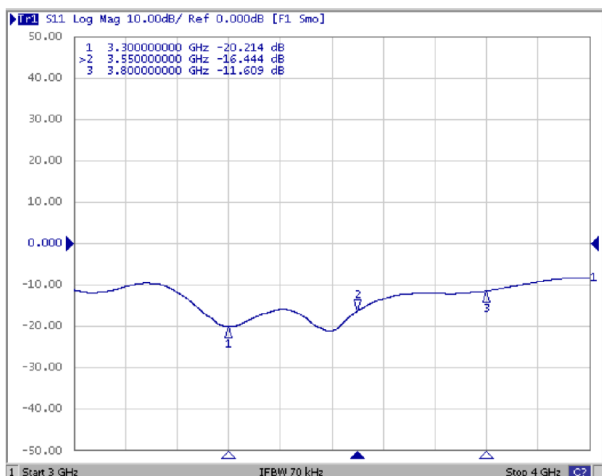

VSWR

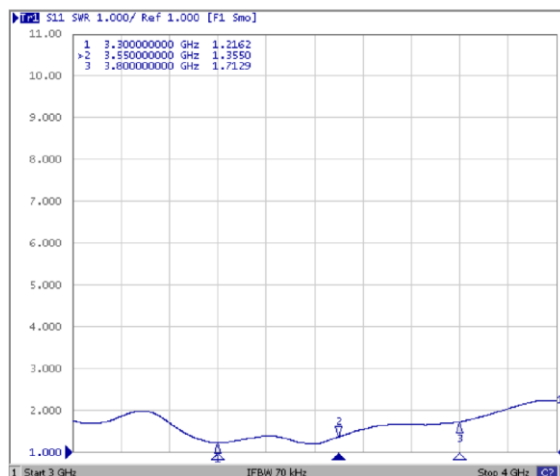

Frequency(MHz) : 3300~3800. Pattern Field : Z-X plane

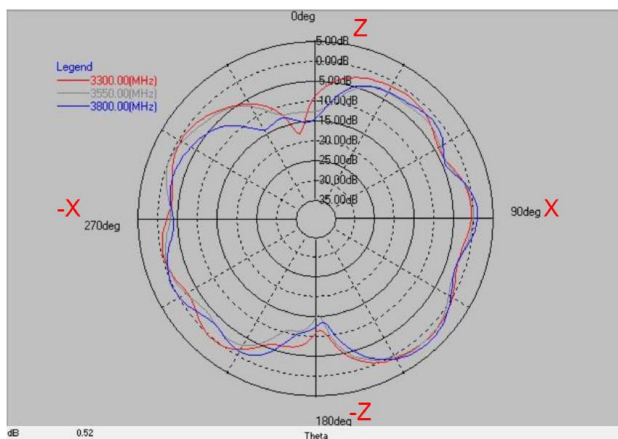

Layer	Max value	Min value	Average
3300(MHz)	1.64 dB	-18.30 dB	-2.05 dB
3550(MHz)	1.57 dB	-15.56 dB	-2.64 dB
3800(MHz)	2.53 dB	-15.60 dB	-2.45 dB

Frequency(MHz) : 3300~3800. Pattern Field : Z-Y plane

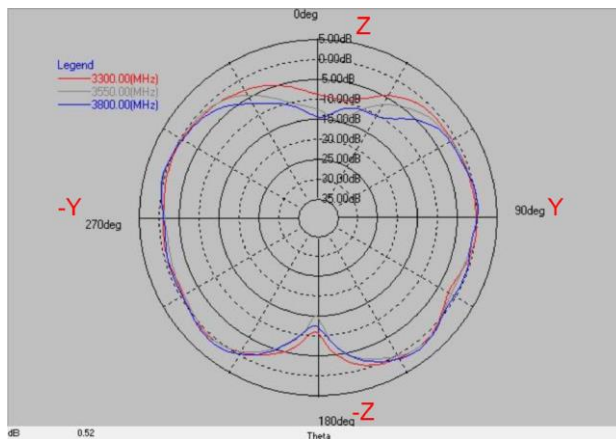

Layer	Max value	Min value	Average
3300(MHz)	1.20 dB	-11.32 dB	-1.61 dB
3550(MHz)	1.32 dB	-15.16 dB	-1.97 dB
3800(MHz)	1.77 dB	-14.75 dB	-1.85 dB

Frequency(MHz) : 3300~3800. Pattern Field : X-Y plane

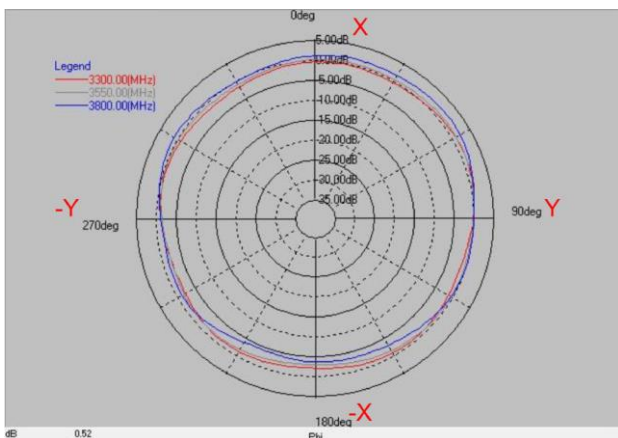

Layer	Max value	Min value	Average
3300(MHz)	1.04 dB	-2.36 dB	-0.90 dB
3550(MHz)	1.14 dB	-3.17 dB	-0.72 dB
3800(MHz)	2.33 dB	-4.43 dB	-0.27 dB

Please be sure to request approval specifications that provide further details of the products. Kindly note that the content of these specifications are subject to change or may be discontinued without prior notice. This product may not be designed/used in medical or high risk applications without Chilisin approval. Please contact our sales department before ordering.

PCB Antenna BTPA Series

3D Peak Gain

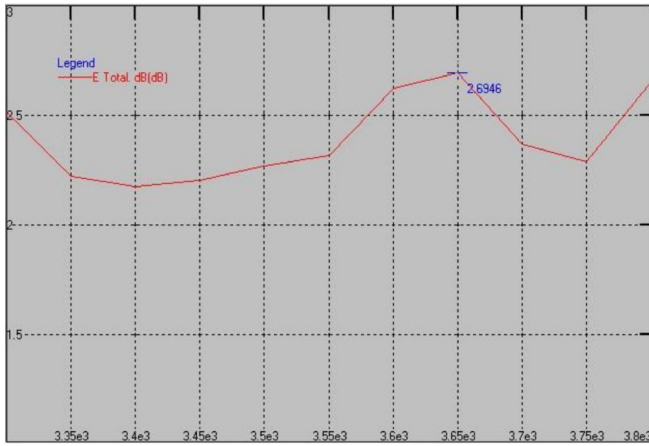

3D Efficiency

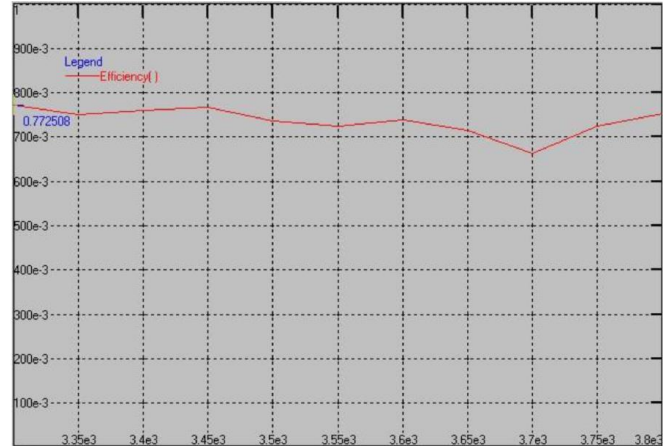

Frequency (MHz)	Peak Gain (dBi)	Efficiency (%)	Frequency (MHz)	Peak Gain (dBi)	Efficiency (%)
3300	2.51	77	3600	2.62	74
3350	2.22	75	3650	2.69	71
3400	2.17	76	3700	2.37	66
3450	2.20	77	3750	2.29	72
3500	2.27	74	3800	2.66	75
3550	2.31	72			

Please be sure to request approval specifications that provide further details of the products. Kindly note that the content of these specifications are subject to change or may be discontinued without prior notice. This product may not be designed/used in medical or high risk applications without Chilisin approval. Please contact our sales department before ordering.

BTPA0012353G9C1A01

Return Loss S11

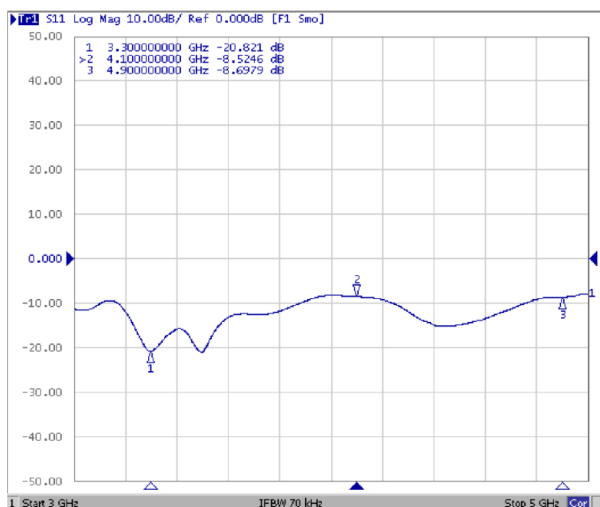

VSWR

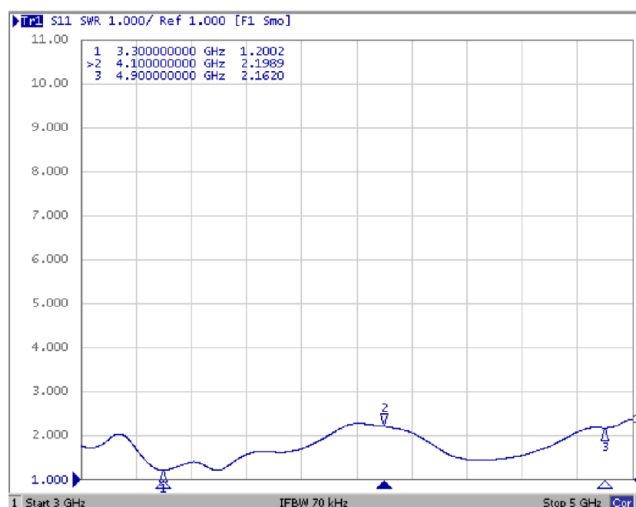

Frequency(MHz) : 3300~4900. Pattern Field : Z-X plane

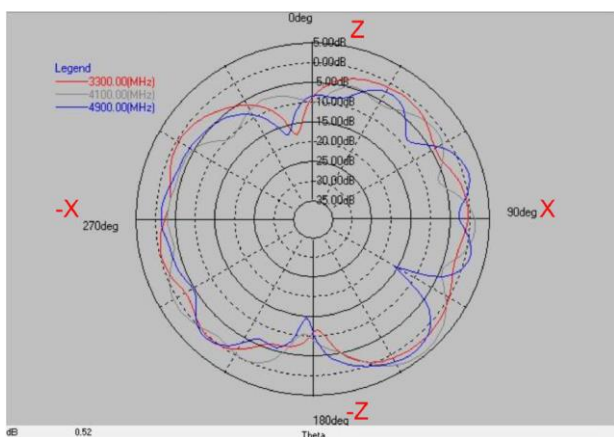

Layer	Max value	Min value	Average
3300(MHz)	1.64 dB	-18.30 dB	-2.05 dB
4100(MHz)	4.25 dB	-10.87 dB	-1.96 dB
4900(MHz)	2.55 dB	-17.75 dB	-2.61 dB

Frequency(MHz) : 3300~4900. Pattern Field : Z-Y plane

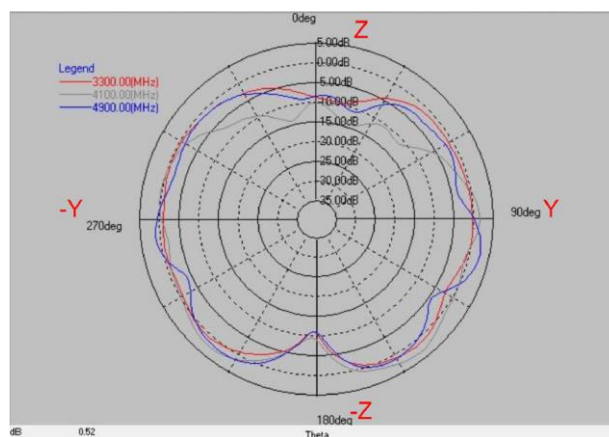

Layer	Max value	Min value	Average
3300(MHz)	1.20 dB	-11.32 dB	-1.61 dB
4100(MHz)	3.09 dB	-14.42 dB	-1.47 dB
4900(MHz)	2.63 dB	-11.22 dB	-1.61 dB

Frequency(MHz) : 3300~4900. Pattern Field : X-Y plane

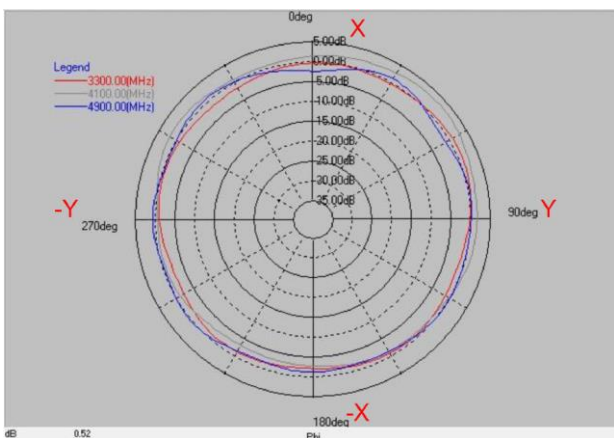

Layer	Max value	Min value	Average
3300(MHz)	1.04 dB	-2.36 dB	-0.90 dB
4100(MHz)	3.30 dB	-3.22 dB	0.54 dB
4900(MHz)	0.90 dB	-2.60 dB	-0.39 dB

Please be sure to request approval specifications that provide further details of the products. Kindly note that the content of these specifications are subject to change or may be discontinued without prior notice. This product may not be designed/used in medical or high risk applications without Chilisin approval. Please contact our sales department before ordering.

PCB Antenna BTPA Series

3D Peak Gain

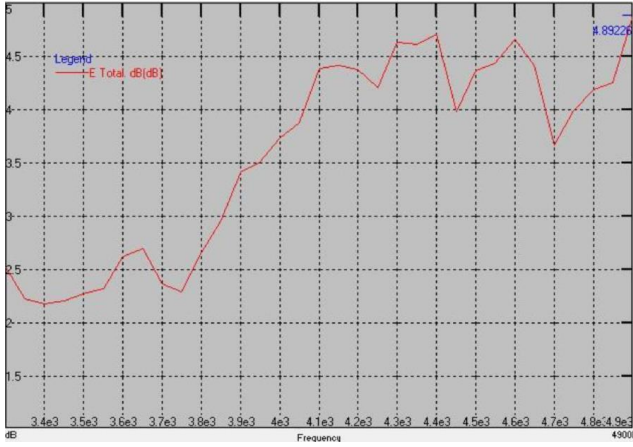

3D Efficiency

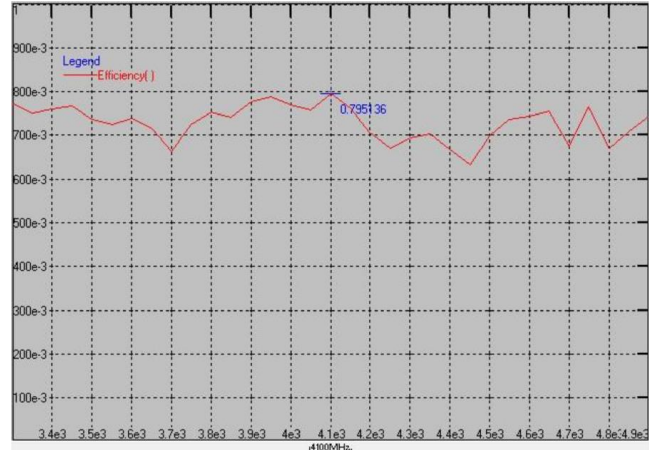

Frequency (MHz)	Peak Gain (dBi)	Efficiency (%)	Frequency (MHz)	Peak Gain (dBi)	Efficiency (%)
3300	2.51	77	4200	4.38	70
3400	2.17	76	4300	4.63	69
3500	2.27	74	4400	4.71	67
3600	2.62	74	4500	4.37	70
3700	2.37	66	4600	4.66	74
3800	2.66	75	4700	3.67	68
3900	3.42	78	4800	4.19	67
4000	3.74	77	4900	4.89	74
4100	4.39	80			

Please be sure to request approval specifications that provide further details of the products. Kindly note that the content of these specifications are subject to change or may be discontinued without prior notice. This product may not be designed/used in medical or high risk applications without Chilisin approval. Please contact our sales department before ordering.

BTPA00221425GC1A09

VSWR S11

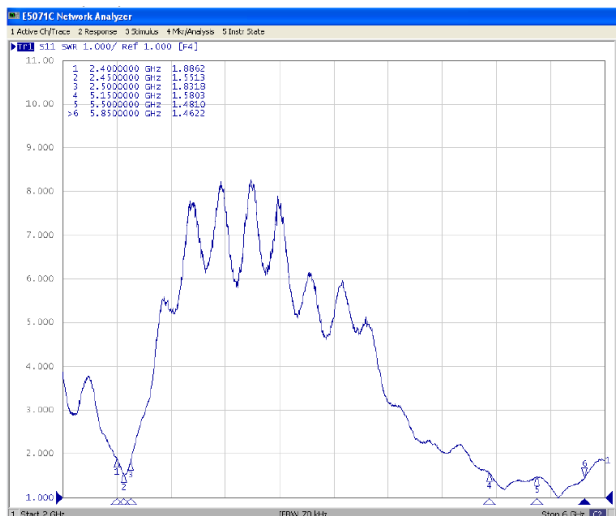

Frequency(MHz) : 2400~2500. Pattern Field : Z-X plane

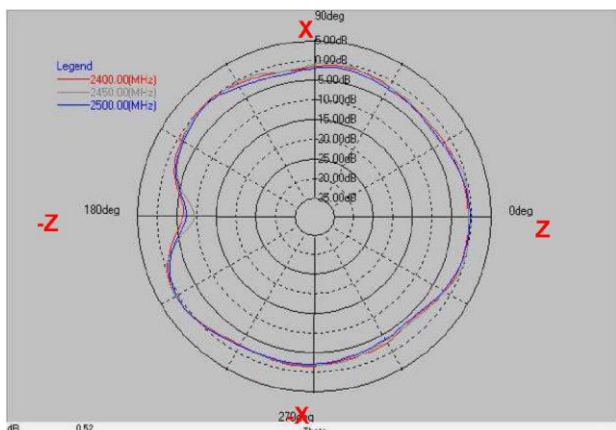

Layer	Max value	Min value	Average
2400(MHz)	0.74 dB	-6.70 dB	-1.60 dB
2450(MHz)	0.87 dB	-9.48 dB	-1.56 dB
2500(MHz)	0.53 dB	-7.47 dB	-1.94 dB

Frequency(MHz) : 2400~2500. Pattern Field : Z-Y plane

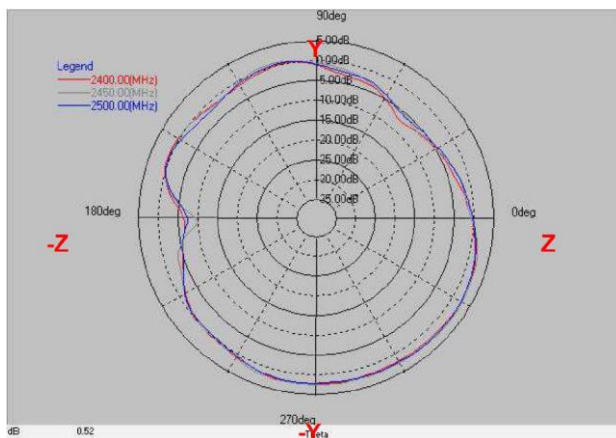

Layer	Max value	Min value	Average
2400(MHz)	2.49 dB	-7.36 dB	-0.29 dB
2450(MHz)	2.78 dB	-9.89 dB	0.00 dB
2500(MHz)	2.58 dB	-7.45 dB	-0.27 dB

Frequency(MHz) : 2400~2500. Pattern Field : X-Y plane

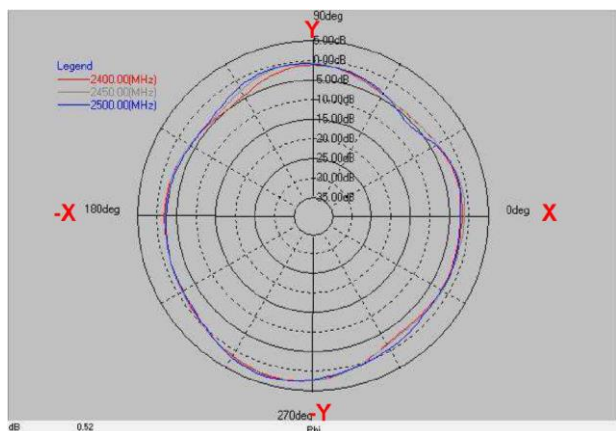

Layer	Max value	Min value	Average
2400(MHz)	2.59 dB	-5.00 dB	-1.36 dB
2450(MHz)	2.75 dB	-4.41 dB	-1.11 dB
2500(MHz)	2.86 dB	-6.11 dB	-1.14 dB

Frequency(MHz) : 5150~5850. Pattern Field : Z-X plane

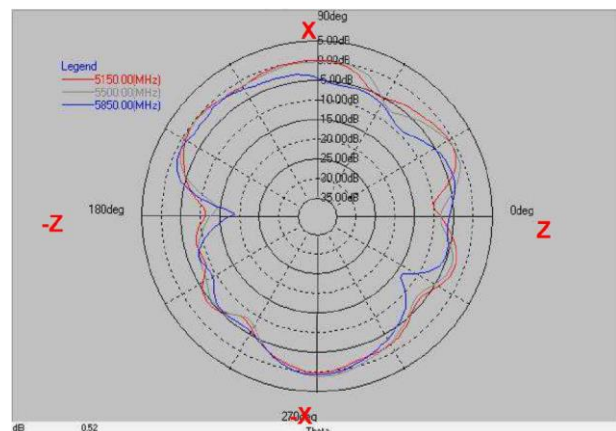

Layer	Max value	Min value	Average
5150(MHz)	0.07 dB	-11.31 dB	-2.91 dB
5500(MHz)	1.03 dB	-14.22 dB	-2.85 dB
5850(MHz)	0.55 dB	-18.79 dB	-4.20 dB

Please be sure to request approval specifications that provide further details of the products. Kindly note that the content of these specifications are subject to change or may be discontinued without prior notice. This product may not be designed/used in medical or high risk applications without Chilisin approval. Please contact our sales department before ordering.

PCB Antenna BTPA Series

Frequency(MHz) : 5150~5850. Pattern Field : Z-Y plane

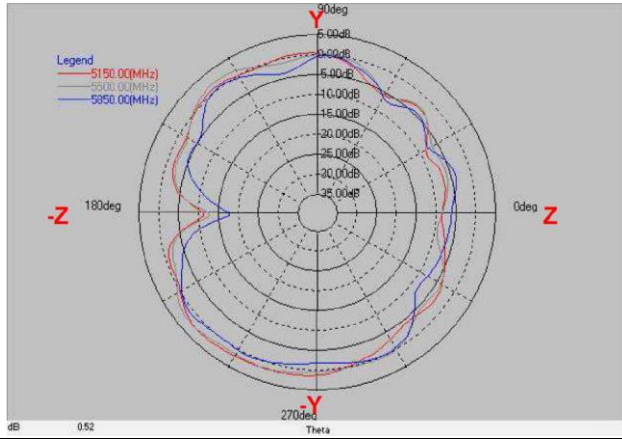

Layer	Max value	Min value	Average
5150(MHz)	2.40 dB	-11.30 dB	-1.43 dB
5500(MHz)	2.53 dB	-12.84 dB	-1.28 dB
5850(MHz)	0.87 dB	-17.84 dB	-2.76 dB

Frequency(MHz) : 5150~5850. Pattern Field : X-Y plane

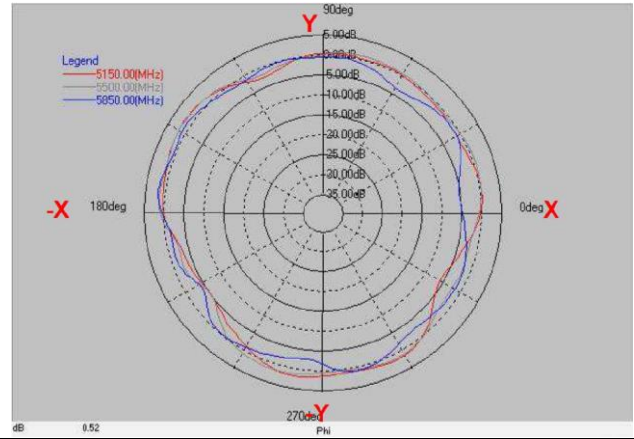

Layer	Max value	Min value	Average
5150(MHz)	1.84 dB	-5.87 dB	-0.47 dB
5500(MHz)	1.80 dB	-5.26 dB	-0.09 dB
5850(MHz)	1.86 dB	-5.27 dB	-1.23 dB

Please be sure to request approval specifications that provide further details of the products. Kindly note that the content of these specifications are subject to change or may be discontinued without prior notice. This product may not be designed/used in medical or high risk applications without Chilisin approval. Please contact our sales department before ordering.

BTPA0030082G4C1A04

Experimental Setup

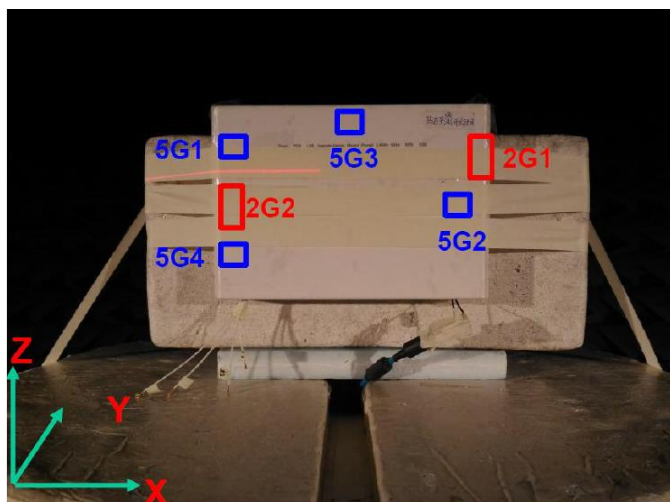

Frequency(MHz) : 2400~2500. Pattern Field : Z-X plane

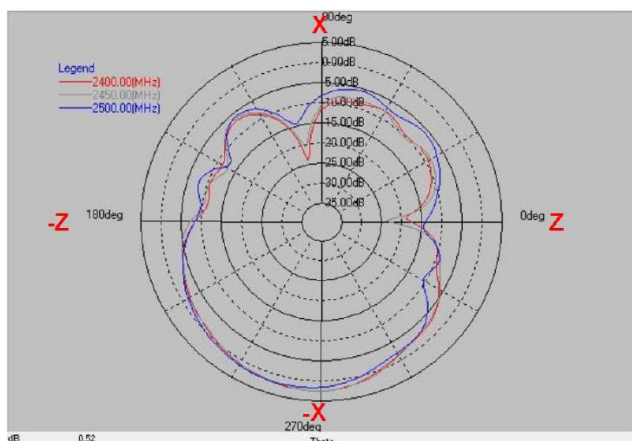

Layer	Max value	Min value	Average
2400(MHz)	2.37 dB	-24.24 dB	-3.61 dB
2450(MHz)	2.34 dB	-23.93 dB	-3.60 dB
2500(MHz)	1.81 dB	-14.70 dB	-3.64 dB

VSWR S22

Tr2 S22 Log Mag 10.00dB/ Ref 0.000dB [F4]

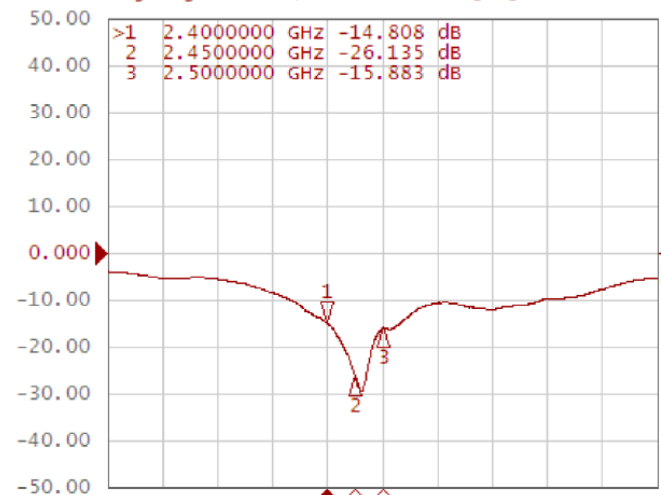

Frequency(MHz) : 2400~2500. Pattern Field : Z-Y plane

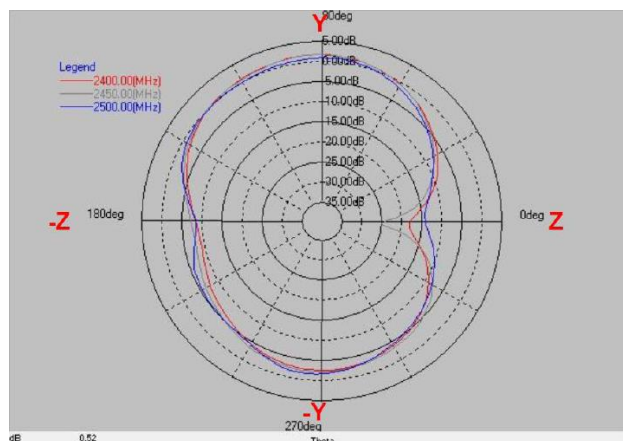

Layer	Max value	Min value	Average
2400(MHz)	1.51 dB	-18.08 dB	-3.04 dB
2450(MHz)	1.53 dB	-25.15 dB	-2.83 dB
2500(MHz)	0.69 dB	-14.21 dB	-3.16 dB

Frequency(MHz) : 2400~2500. Pattern Field : X-Y plane

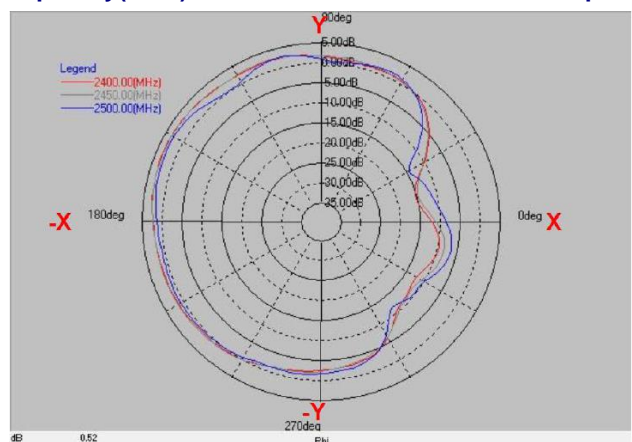

Layer	Max value	Min value	Average
2400(MHz)	3.37 dB	-15.39 dB	-0.20 dB
2450(MHz)	3.25 dB	-14.73 dB	-0.14 dB
2500(MHz)	2.75 dB	-14.49 dB	-0.72 dB

Please be sure to request approval specifications that provide further details of the products. Kindly note that the content of these specifications are subject to change or may be discontinued without prior notice. This product may not be designed/used in medical or high risk applications without Chilisin approval. Please contact our sales department before ordering.

BTPA00420725GC1A04

Return Loss

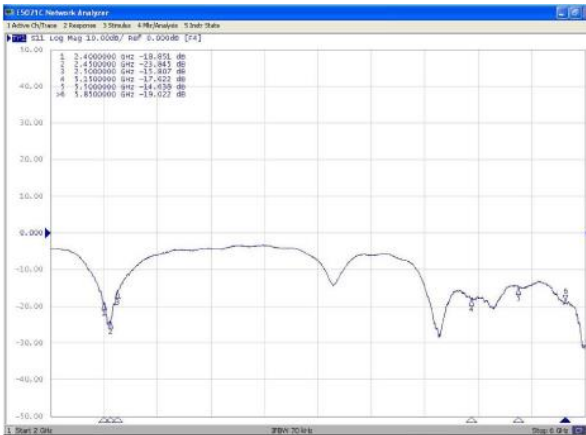

Frequency(MHz): 2400~2500. Pattern Field: Z-X plane

Frequency(MHz): 2400~2500. Pattern Field: Z-Y plane

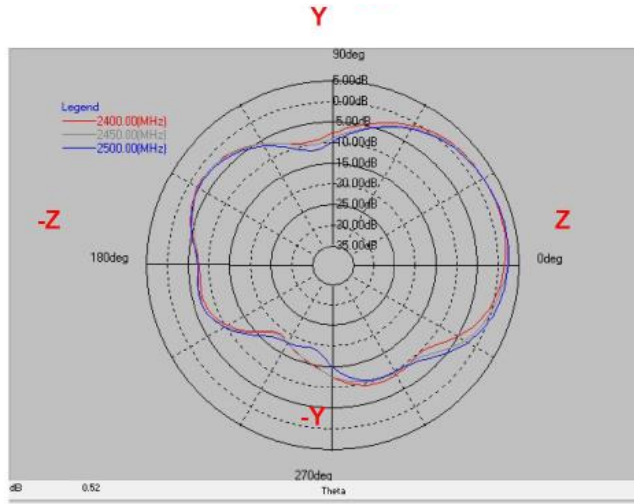
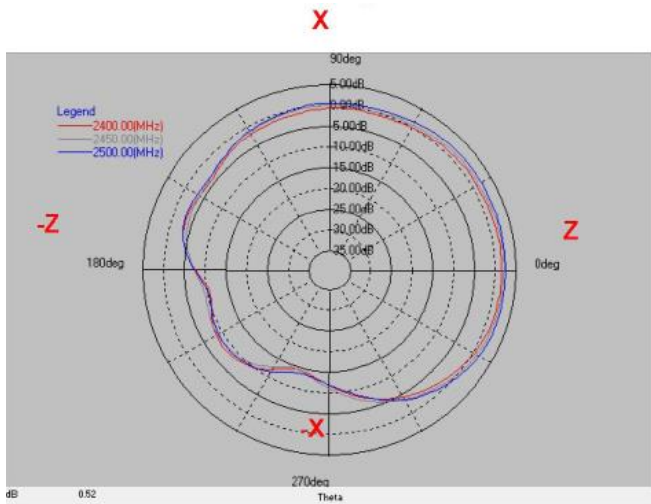

Layer	Max value	Min value	Average
2400(MHz)	1.66 dB	-14.74 dB	-2.07 dB
2450(MHz)	2.26 dB	-14.76 dB	-1.53 dB
2500(MHz)	2.58 dB	-14.02 dB	-1.02 dB

Layer	Max value	Min value	Average
2400(MHz)	2.42 dB	-18.93 dB	-3.22 dB
2450(MHz)	2.73 dB	-18.60 dB	-3.11 dB
2500(MHz)	2.82 dB	-19.18 dB	-3.03 dB

Frequency(MHz): 2400~2500. Pattern Field: X-Y plane

Frequency(MHz): 5150~5850. Pattern Field: Z-X plane

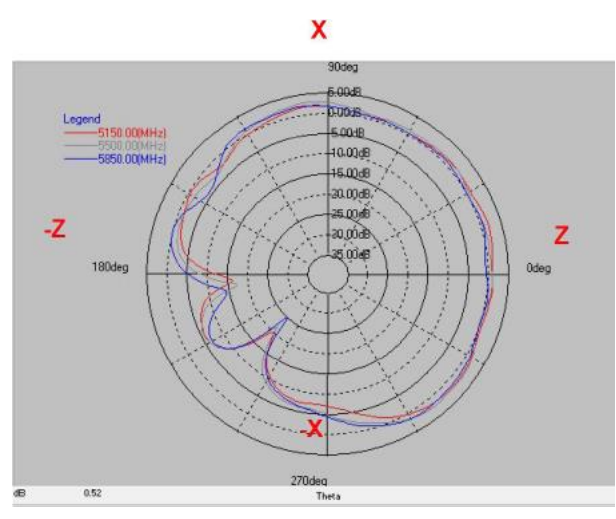
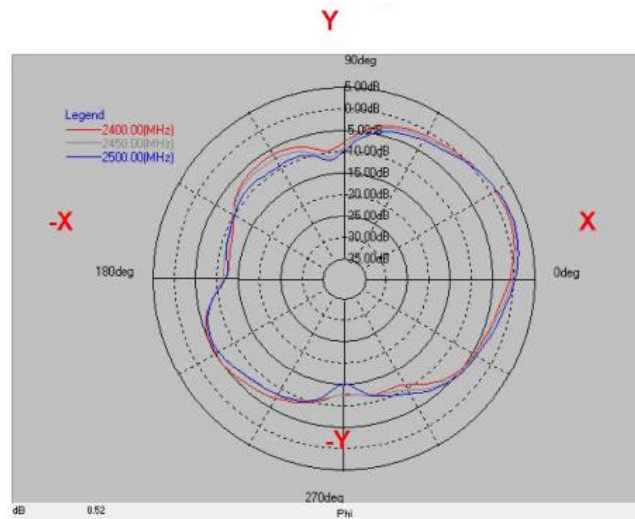

Layer	Max value	Min value	Average
2400(MHz)	1.64 dB	-12.87 dB	-4.24 dB
2450(MHz)	2.07 dB	-21.91 dB	-4.24 dB
2500(MHz)	2.28 dB	-15.30 dB	-4.22 dB

Layer	Max value	Min value	Average
5150(MHz)	1.95 dB	-19.79 dB	-0.87 dB
5500(MHz)	2.82 dB	-22.02 dB	-0.54 dB
5850(MHz)	1.93 dB	-25.20 dB	-0.86 dB

Please be sure to request approval specifications that provide further details of the products. Kindly note that the content of these specifications are subject to change or may be discontinued without prior notice. This product may not be designed/used in medical or high risk applications without Chilisin approval. Please contact our sales department before ordering.

PCB Antenna BTPA Series

Frequency(MHz): 5150~5850. Pattern Field: Z-Y plane

Frequency(MHz): 5150~5850. Pattern Field: X-Y plane

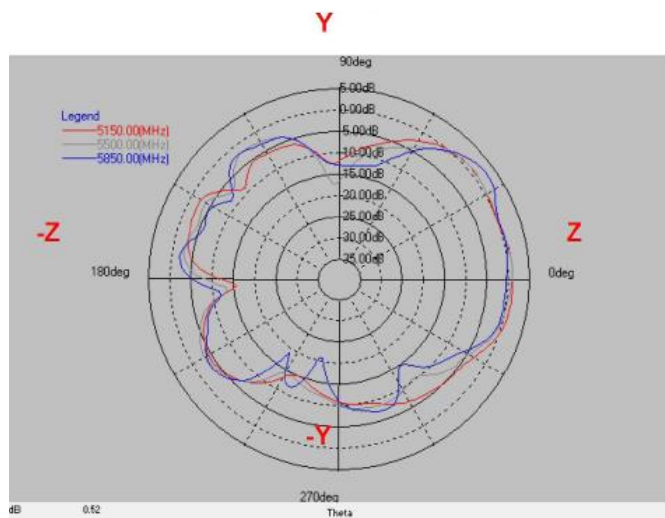

Layer	Max value	Min value	Average
5150(MHz)	1.17 dB	-15.67 dB	-3.69 dB
5500(MHz)	1.07 dB	-17.54 dB	-3.84 dB
5850(MHz)	2.86 dB	-21.22 dB	-3.87 dB

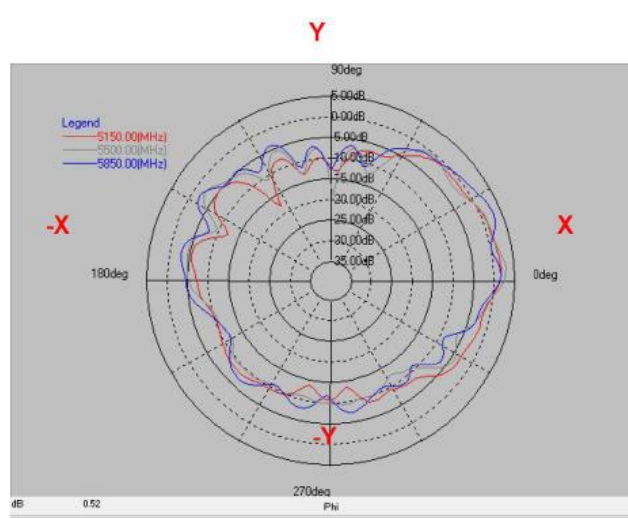

Layer	Max value	Min value	Average
5150(MHz)	1.84 dB	-18.20 dB	-4.72 dB
5500(MHz)	3.11 dB	-19.19 dB	-4.54 dB
5850(MHz)	3.12 dB	-13.07 dB	-3.99 dB

Please be sure to request approval specifications that provide further details of the products. Kindly note that the content of these specifications are subject to change or may be discontinued without prior notice. This product may not be designed/used in medical or high risk applications without Chilisin approval. Please contact our sales department before ordering.

BTPA0046062G4C1B03

Return Loss

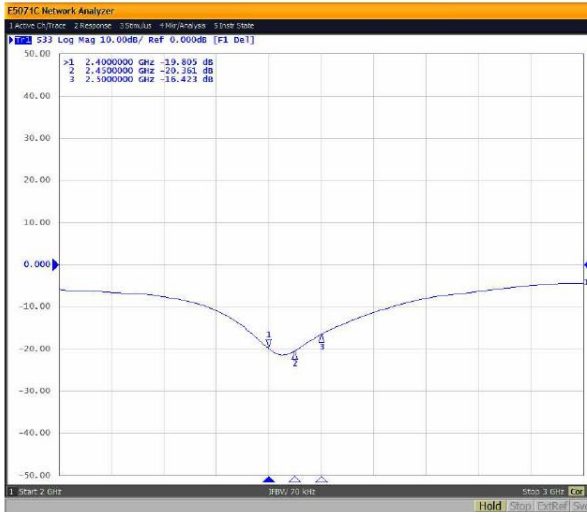

Frequency(MHz): 2400~2500. Pattern Field: X-Z plane

Experimental Setup

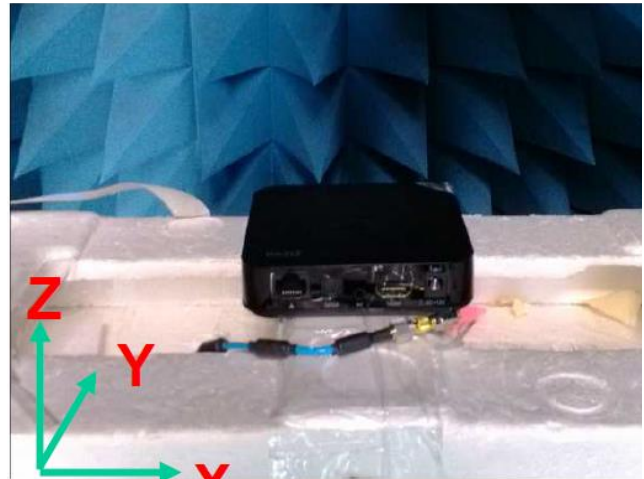

Frequency(MHz): 2400~2500. Pattern Field: Y-Z plane

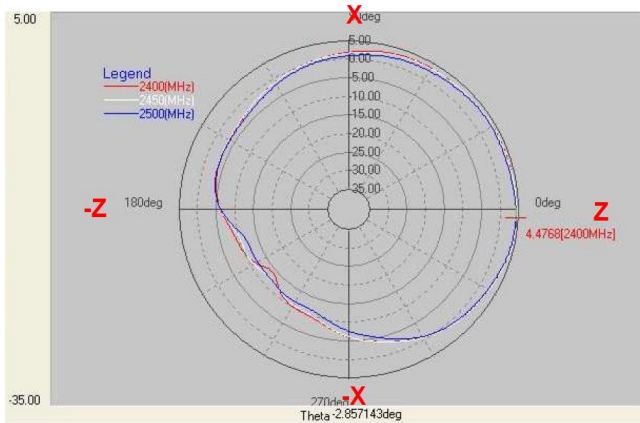

Layer	Max value	Average
2400(MHz)	4.48 dB	0.47 dB
2450(MHz)	4.61 dB	0.47 dB
2500(MHz)	4.35 dB	0.03 dB

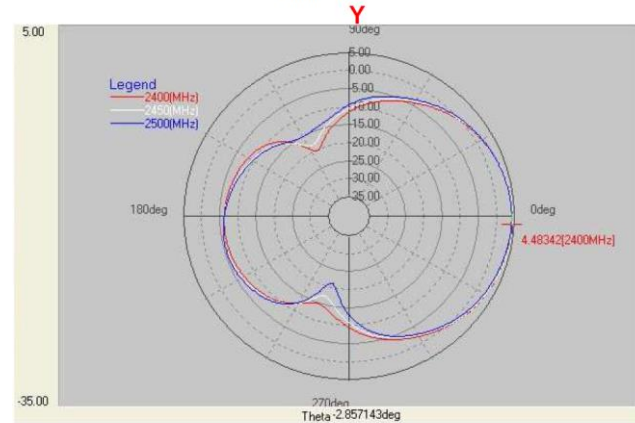

Layer	Max value	Average
2400(MHz)	4.48 dB	-1.74 dB
2450(MHz)	4.58 dB	-1.71 dB
2500(MHz)	4.28 dB	-1.89 dB

Frequency(MHz): 2400~2500. Pattern Field: X-Y plane

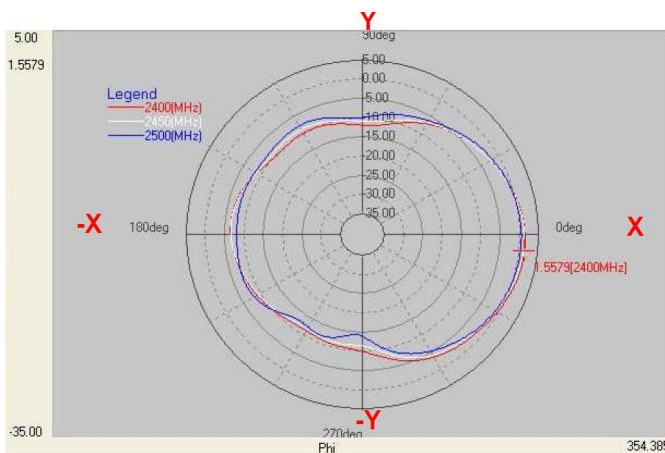

Layer	Max value	Average
2400(MHz)	1.56 dB	-4.52 dB
2450(MHz)	1.33 dB	-4.76 dB
2500(MHz)	0.58 dB	-4.93 dB

Please be sure to request approval specifications that provide further details of the products. Kindly note that the content of these specifications are subject to change or may be discontinued without prior notice. This product may not be designed/used in medical or high risk applications without Chilisin approval. Please contact our sales department before ordering.

BTPA0052116G0C1A01

Return Loss

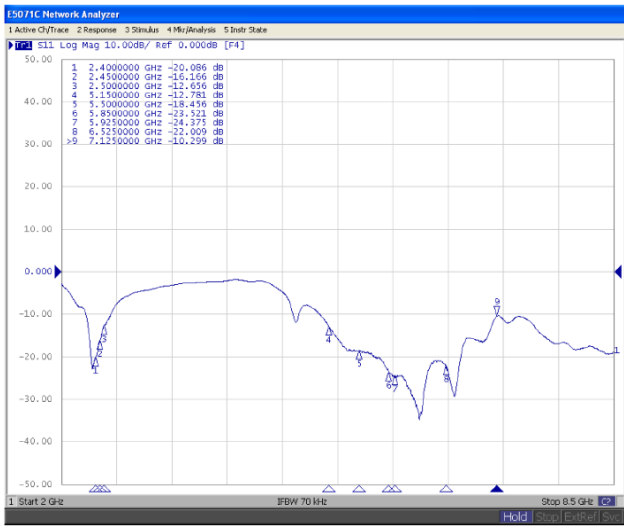

3D Peak Gain

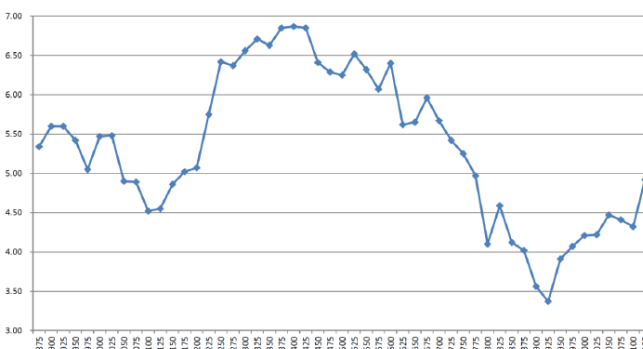
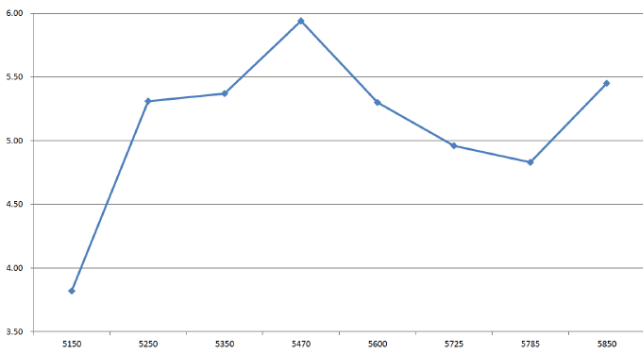
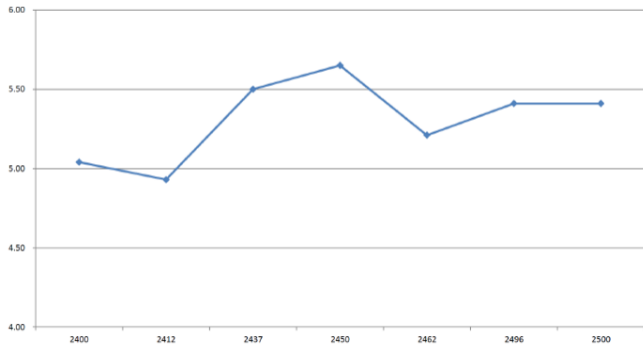

3D Efficiency

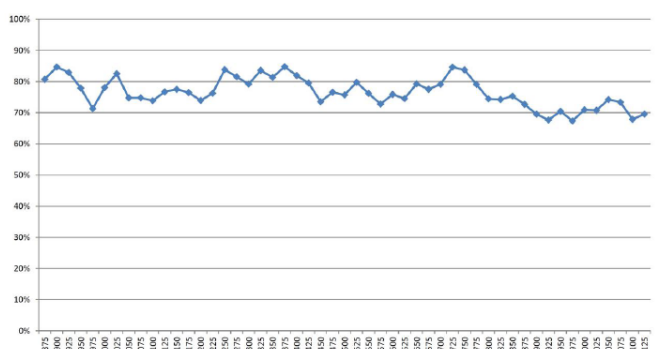
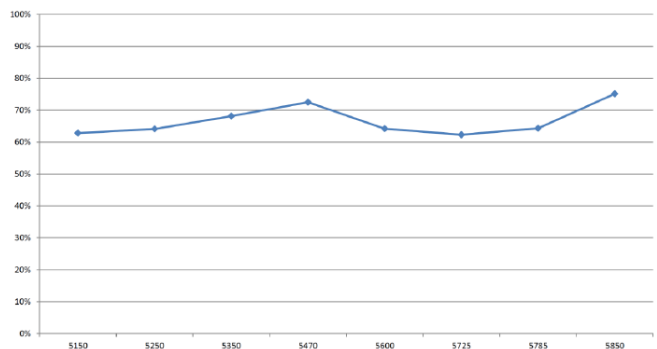
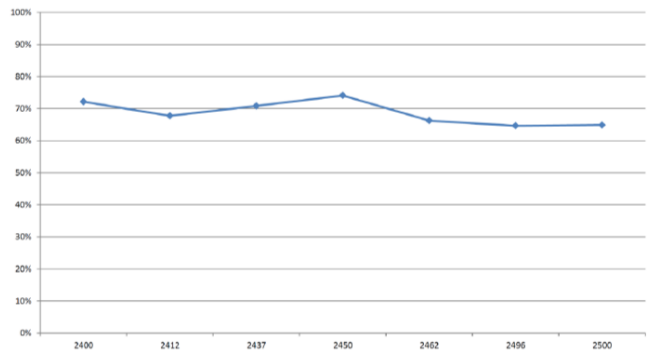

Please be sure to request approval specifications that provide further details of the products. Kindly note that the content of these specifications are subject to change or may be discontinued without prior notice. This product may not be designed/used in medical or high risk applications without Chilisin approval. Please contact our sales department before ordering.

PCB Antenna BTPA Series

Frequency (MHz)	Peak Gain (dBi)	Efficiency (%)	Frequency (MHz)	Peak Gain (dBi)	Efficiency (%)
2400	5.04	72	6325	6.71	84
2412	4.93	68	6350	6.63	81
2437	5.50	71	6375	6.85	85
2450	5.65	74	6400	6.87	82
2462	5.21	66	6425	6.85	80
2496	5.41	65	6450	6.41	74
2500	5.41	65	6475	6.29	77
5150	3.82	63	6500	6.25	76
5250	5.31	64	6525	6.52	80
5350	5.37	68	6550	6.32	76
5470	5.94	73	6575	6.07	73
5600	5.30	64	6600	6.40	76
5725	4.96	62	6625	5.62	75
5785	4.83	64	6650	5.65	79
5850	5.45	75	6675	5.96	78
5875	5.34	81	6700	5.67	79
5900	5.60	85	6725	5.42	85
5925	5.60	83	6750	5.25	84
5950	5.42	78	6775	4.97	79
5975	5.05	71	6800	4.10	74
6000	5.47	78	6825	4.59	74
6025	5.48	83	6850	4.12	75
6050	4.90	75	6875	4.02	73
6075	4.89	75	6900	3.56	70
6100	4.52	74	6925	3.37	68
6125	4.55	77	6950	3.91	70
6150	4.86	78	6975	4.07	67
6175	5.02	76	7000	4.21	71
6200	5.07	74	7025	4.22	71
6225	5.75	76	7050	4.47	74
6250	6.42	84	7075	4.41	73
6275	6.37	82	7100	4.32	68
6300	6.56	79	7125	4.92	70

Please be sure to request approval specifications that provide further details of the products. Kindly note that the content of these specifications are subject to change or may be discontinued without prior notice. This product may not be designed/used in medical or high risk applications without Chilisin approval. Please contact our sales department before ordering.