



FEATURES

- Recreate Concert Sound Without Initial Encoding
- Single Definition Control for Ease of Adjustment
- Fixed or Variable Bass Boost Control
- Super Low Noise: -95dBA Typ. IEC-A Weighted
- No Undesirable "Pumping" or "Breathing" Effects
- Matched Circuits for Stereo Applications
- Buffered Outputs
- Transducer Independent
- No Extra Speakers Needed

APPLICATIONS

- Home Stereo Systems
- Television Sound Systems (Stereo Ready)
- Portable Battery Powered Stereo Systems
- Automobile Stereo Systems
- Telephones and Answering Machines
- Multimedia Personal Computers

GENERAL DESCRIPTION

The XR-1071 is an improved version of the high definition audio matched-pair sound enhancement processor using the patented BBE® II sound enhancement technique. It is designed for use with stereo sound systems to enhance the music to provide more realism to the sound regardless of its source. No initial encoding of the source signal is needed to achieve the sound enhancement. The XR-1071 provides this enhancement without additional speakers and is compatible with full-sized and headphone transducers for use with a variety of systems. With the use of the DEFINITION control, the amount of enhancement can be adjusted to the preference of the listener. This single control affects both channels equally,

reducing the complexity of the system adjustment. In addition, bass boost control is also provided to balance the dynamically changing high-band. Several fixed-level or variable-level configurations with minimal external components are possible. Furthermore, a single control disables the sound enhancement with internal analog switches.

The XR-1071 is fabricated using bipolar technology to provide extremely low noise (-95dBA typ.), low total harmonic distortion, and acceptable current consumption (15mA typ.) for battery operated applications and is available in 32-lead Shrink DIP and 44-lead PQFP packages.

ORDERING INFORMATION

Part No.	Package	Operating Temperature Range
XR-1071CP	32-Lead 400 Mil SDIP	-30°C to +75°C
XR-1071CQ	44-Lead Plastic QFP (10mm X 10mm)	-30°C to +75°C



BLOCK DIAGRAM

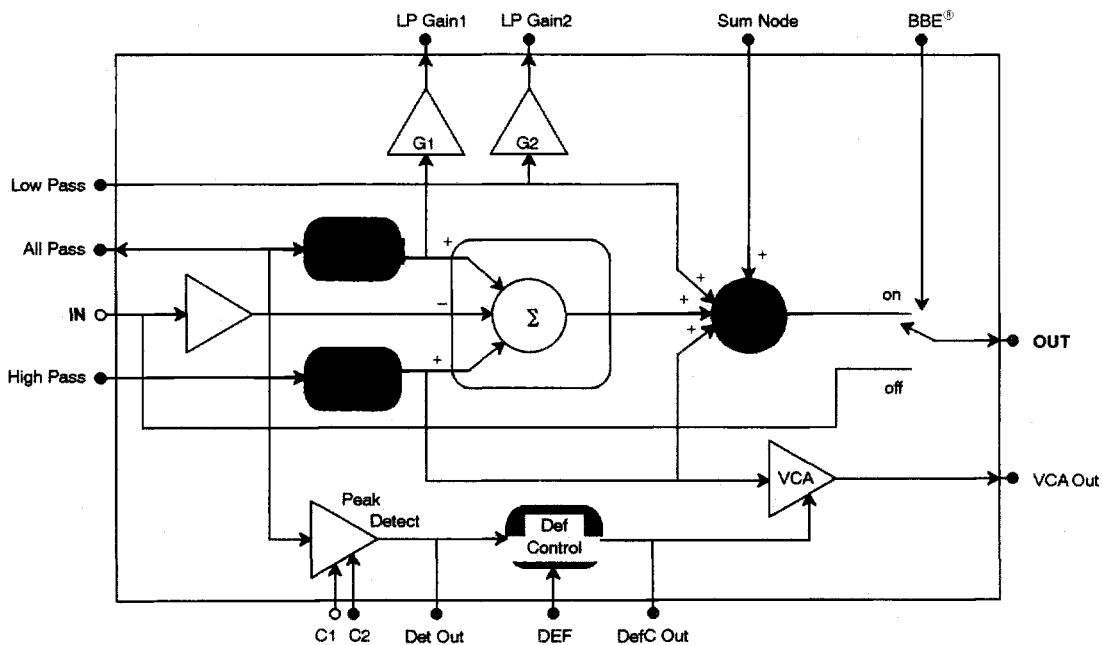
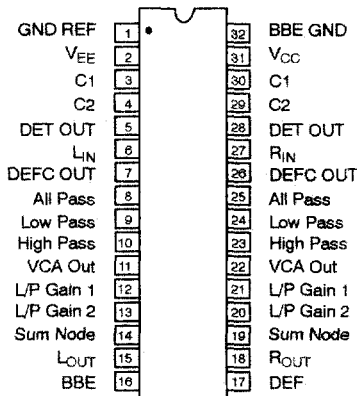
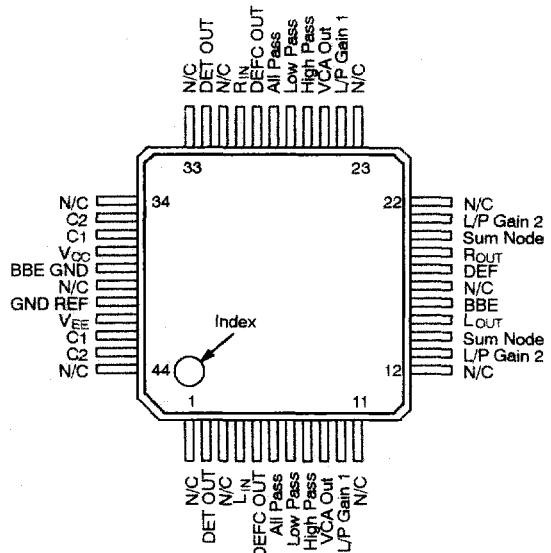

Figure 1. Block Diagram - One Channel of XR-1071

PIN CONFIGURATION



32-Lead SDIP (0.400")



44-Lead PQFP

PIN DESCRIPTION

Pin # QFP	Pin # DIP	Symbol	Type	Description
40	1	GND REF	I	Ground Reference Input. This is the reference input to the BBE® Analog Ground generating circuit. Since the circuit is self biased, only a capacitor need be connected.
41	2	VEE	P	Negative Power Supply.
42,36	3,30	C1	-	Capacitor One. Connection point for peak detector capacitor.
43,35	4,29	C2	-	Capacitor Two. Connection point for peak detector capacitor.
2,32	5,28	DET OUT	O	Detector Output. Connection point for capacitor on output of peak detector.
4	6	LIN	I	Left Channel Input.
5,29	7,26	DEFC OUT	O	Definition Control Output. Connection point for capacitor on output of definition control circuit.
6,28	8,25	All Pass	O	All Pass Output. Buffered output of signal to be fed thru capacitor to High Pass Input.
7,27	9,24	Low Pass	I	Low Pass. Connection point for low pass filter capacitor.
8,26	10,23	High Pass	I	High Pass Input. The high pass filter capacitor is connected between this point and the All Pass Output.



PIN DESCRIPTION (CONT'D)

Pin # QFP	Pin # DIP	Symbol	Type	Description
9,25	11,22	VCA Out	O	Voltage Controlled Amplifier Output. The VCA output is capacitively coupled from this point to the Sum Node.
13,21	13,20	L/P Gain 2	O	Low Pass Gain Two Output. See text for explanation.
14,20	14,19	Sum Node	I	Summing Node Input. Additional high and low signals generated elsewhere are added to the signal at this pin.
15	15	L _{OUT}	O	Left Channel Output.
16	16	BBE [®]	I	BBE[®] Bypass Control Input. Control point for internal bypass switches. Controls both channels.
18	17	DEF	I	Definition Control Input. Control point for amount of amplitude compensation in the high band. Controls both channels.
19	18	R _{OUT}	O	Right Channel Output.
30	27	R _{IN}	I	Right Channel Input.
37	31	V _{CC}	P	Positive Power Supply.
38	32	BBE [®] GND	O	BBE[®] Ground Output. This is the output to the BBE [®] analog ground generating circuit. This very clean ground is used for several peripheral component connections.
10,24	12,21	L/P Gain 1	O	Low Pass Gain One Output. See text for explanation.

Notes

The following pins are no connect (N/C) in 44-PQFP package: 1,3,11,12,17,22,23,31,33,34,39,44.

RECOMMENDED DC OPERATING CONDITIONS

Symbol	Parameter	Min.	Typ.	Max.	Unit	Conditions
$V_{CC} - V_{EE}$	Total Supply Voltage	6		24.0	V	PDIP package
$V_{CC} - V_C$	Total Supply Voltage	6		20.8	V	PQFP package

ELECTRICAL CHARACTERISTICS

Test Conditions: $V_{CC} = +5VDC$, $V_{EE} = -5VDC$, $T_A = +25^\circ C$ unless otherwise specified.

Symbol	Parameter	Min.	Typ.	Max.	Unit	Conditions
General Characteristics						
I_{CC}	Positive Supply Current		15.0	20.0	mA	
I_{EE}	Negative Supply Current		15.0	20.0	mA	
V_{REG}	Regulator Output	-400	-275	-150	mV	No load
$\Delta V_O / \Delta I_O$	Load Regulation	-20	-5	+10	mV	+1mA load
Filter						
A_{MB}	Midband Signal Path Gain	1.1	1.6	2.1	dB	
A_{LB1}	Loband Signal Path 1 Gain	0.0	0.5	1.0	dB	
A_{LB2}	Loband Signal Path 2 Gain	4.5	5.0	5.5	dB	
A_{LB3}	Loband Signal Path 3 Gain	7.0	7.5	8.0	dB	
A_{LB4}	Loband Signal Path 4 Gain	9.2	9.9	10.7	dB	
A_{HB}	Unboosted Hiband Signal Path Gain	-0.4	0.7	1.6	dB	
A_{HBMAX}	Max Boost Hiband Signal Path Gain	8.7	9.7	10.7	dB	
A_{OFF}	Gain of BBE® OFF Signal Path	-0.5	0.0	0.5	dB	
Rectifier						
N_{ON}	Noise in BBE®ON Mode		-95		dBA	(IEC-A weighted) Bass Boost = min
			-93		dBA	Bass Boost = max
N_{OFF}	Noise in BBE®OFF (Bypass) Mode		-113		dBA	(IEC-A)
PSRR	Power Supply Ripple Rejection		30		dB	10Hz
			45		dB	60Hz
			50		dB	100Hz

Specifications are subject to change without notice

ABSOLUTE MAXIMUM RATINGS

Power Supply Voltage: $V_{CC} - V_{EE}$ 26 VDC
 Power Dissipation (package limitation) @ 25°C
 32-Lead SDIP package 1W
 Derate above 25°C 9mW/°C
 44-Lead PQFP package 817mW

Derate above 25°C 8mW/°C
 Storage Temperature -65°C to +150°C
 Maximum Input Voltage $V_{CC} + 0.3V$
 Minimum Input Voltage $V_{EE} - 0.3V$

SYSTEM DESCRIPTION

The XR-1071 is designed to provide even more life-like audio to reproduced sound than previous versions of the BBE® Sound Processors. The XR-1071 would normally be located in the preamplifier section of a sound system after the tuner or input section and before the amplifier stages that drive the transducers (speakers or headphones). Since no initial encoding of the signal source is needed, virtually any audio signal, including both monaural and stereo broadcasts and recordings, can benefit from the use of the XR-1071 BBE®II sound enhancement processor.

PRINCIPLES OF OPERATION

The XR-1071 provides a means to compensate for the transient distortion caused by the non-ideal interface between amplifier and transducer. BBE® sound enhancement compensates for this distortion by making corrections to the amplitude and phase.

PHASE COMPENSATION

Phase compensation is utilized to change the time sequence of the frequency spectrum so that the transducer may reproduce the sound envelope more faithfully. The time shift introduced by the phase compensation is fixed internally and is not controlled by the user.

The block diagram of *Figure 1.* shows one channel of the stereo XR-1071 device. Signal entering the device at IN is buffered and filtered into three bands (Lo, Mid, and Hi) by the LPF, BPF, and HPF. Note that the HPF is fed via the All Pass output. Also note that the BPF is generated by subtracting the signal from the LPF and HPF outputs. In this way, the BPF output is at -180° phase, and the HPF is at -360° phase. All signal paths are recombined at the final summing node. The total system phase response is approximately linear and remains virtually unchanged regardless of all system adjustments (see *Figure 2.*). In this way, the appropriate phase compensation for proper sound enhancement is guaranteed.

AMPLITUDE COMPENSATION

With the DEFINITION control, adjustments can be made for different types and sizes of transducers and

environments, and for the personal preference of the listener. The DEFINITION control indicates the degree of amplitude compensation for the high frequencies of the incoming signal. This circuit has been improved to eliminate undesirable "pumping" and "breathing" effects while improving musical quality and voice intelligibility.

Referring again to the block diagram of *Figure 1.*, the buffered input signal is monitored by a single, wide-band peak detector. Both the detector's output and a voltage at DEF are fed to the DEF Control circuit. The voltage at DEF is listener adjusted via a 5K linear-taper potentiometer. In this way, the DEF Control circuit generates a control voltage for the VCA that is based on the amount of music present and input from the listener. The Hiband signal fed to the VCA is then amplified according to this control voltage. The additional Hiband from the VCA output is recombined with the signal via the Sum Node input. The result is a dynamically changing Hiband with the listener adjusting the maximum boost. The resulting gain curves can be seen on the right half of *Figure 3.*

It should be noted that a single DEF input controls both channels of the dual channel device.

BASS BOOST

Bass boost control is implemented to give a fuller sound complementing the dynamically changing high frequency band. The bass boost control can be configured as fixed or left variable for adjustment by the listener.

Bass boost is accomplished by G1 and G2 from *Figure 1.*, which independently amplify the Loband signal. Outputs L/P Gain1 and/or L/P Gain2 may be used to add additional Loband signal via the Sum Node input. Resulting gain curves can be seen in the left half of *Figure 3.*

The level of bass boost can be fixed to any of four levels shown in the table of *Figure 4.* without the use of any external components (see *Figure 6.a.*). If variation is desired, switches can be used for listener selection from these four levels (see *Fig.6b.*). Fixed resistors can be used to set a customized fixed boost level (see *Figure 6.c.*). Boost versus resistance can be seen in *Figure 5.* Even more elegant, the use of two ganged audio-taper 100k Ω potentiometers will allow finely adjustable bass boost ranges (see *Figure 6.d.*).

BBE[®] BYPASS FUNCTION

The XR-1071 has on-board bypass capability. Noise in the bypass mode is extremely low (-113dBA). The BBE[®] bypass function is performed by two internal analog switches (one for each channel). These switches can be controlled with one external SPST switch, as seen in *Figure 7*. Pin 16 has an internal pulldown current such that the external switch needs only a single throw. The external resistor R_S can be calculated as follows:

$$R_{S_{max}} = \frac{(V_{CC} - V_{EE}) \text{ min}}{72\mu\text{A}} \Omega$$

If R_S is too large, the internal switch circuit may not function properly. If R_S is too small, "popping" sounds may occur when switching to and from bypass mode.

POWER CONNECTION

The XR-1071 has internal biasing for analog reference, eliminating the need for an external bias source in single-supply applications. However, the XR-1071 can also be used in split-supply applications. The BBE[®] Gnd output pin is approximately half-way between the supply voltages and is provided for several key connections to minimize noise feed-through. Appropriate connections can be seen in *Figure 7*.

LICENSE AGREEMENT

The XR-1071 is manufactured by EXAR under license from BBE[®] Sound, Inc. BBE[®] is a registered trademark of BBE[®] Sound, Inc. A license from BBE[®] Sound, Inc. (tel. 714-897-6766) is required before the XR-1071 can be purchased from EXAR.



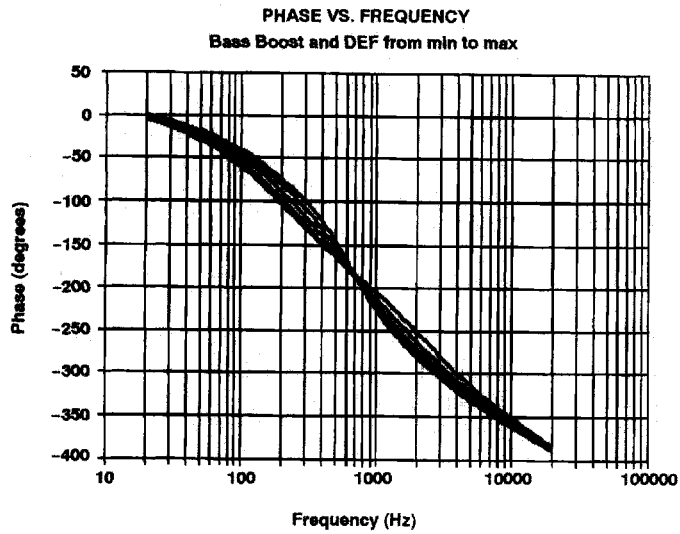

Figure 2. Phase Response

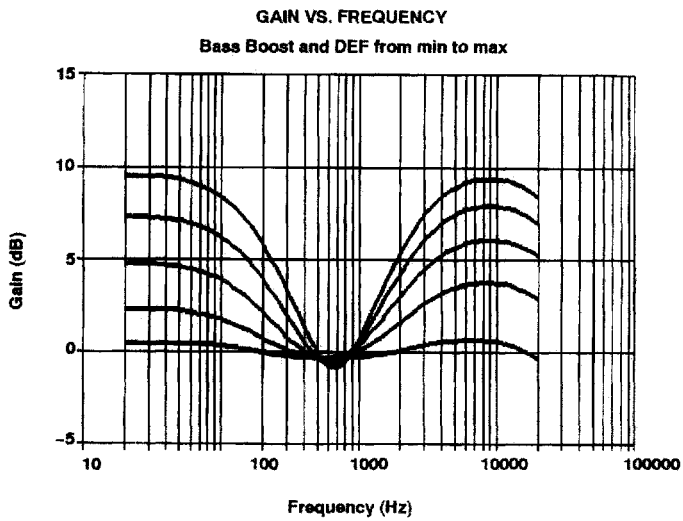

Figure 3. Gain Response

Path#	Connections		Fixed Path Gain	Gain With 100K Ω Pot
	L/P Gain2	L/P Gain1		
1	no	no	0.5dB	n/a
2	no	yes	5.0dB	1.1 to 5.0dB
3	yes	no	7.5dB	1.1 to 7.5dB
4	yes	yes	9.9dB	1.1 to 9.9dB

Figure 4. Bass Boost - Connection and Control

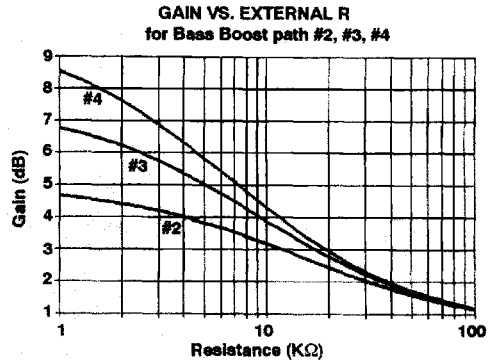
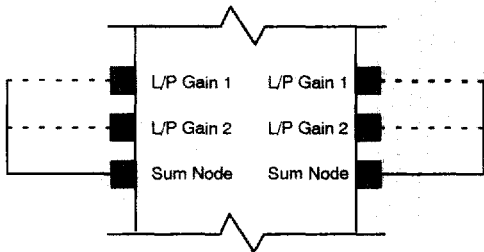
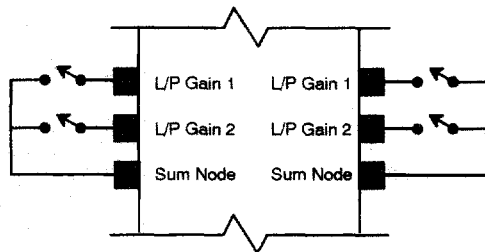

Figure 5. Bass Boost - Variable Control



a) Fixed - Connection Controlled



b) Variable - Switched Controlled

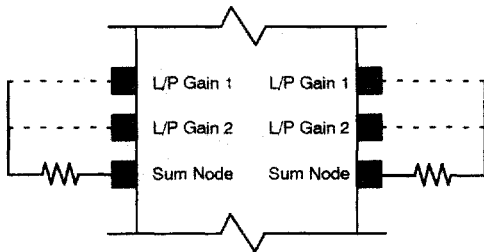

c) Fixed - Resistor Controlled

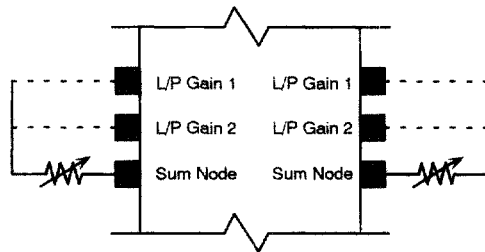

d) Variable - Potentiometer Controlled (audio taper)

Figure 6. Fixed and Variable Control Configurations for Bass Boost (DIP Package)

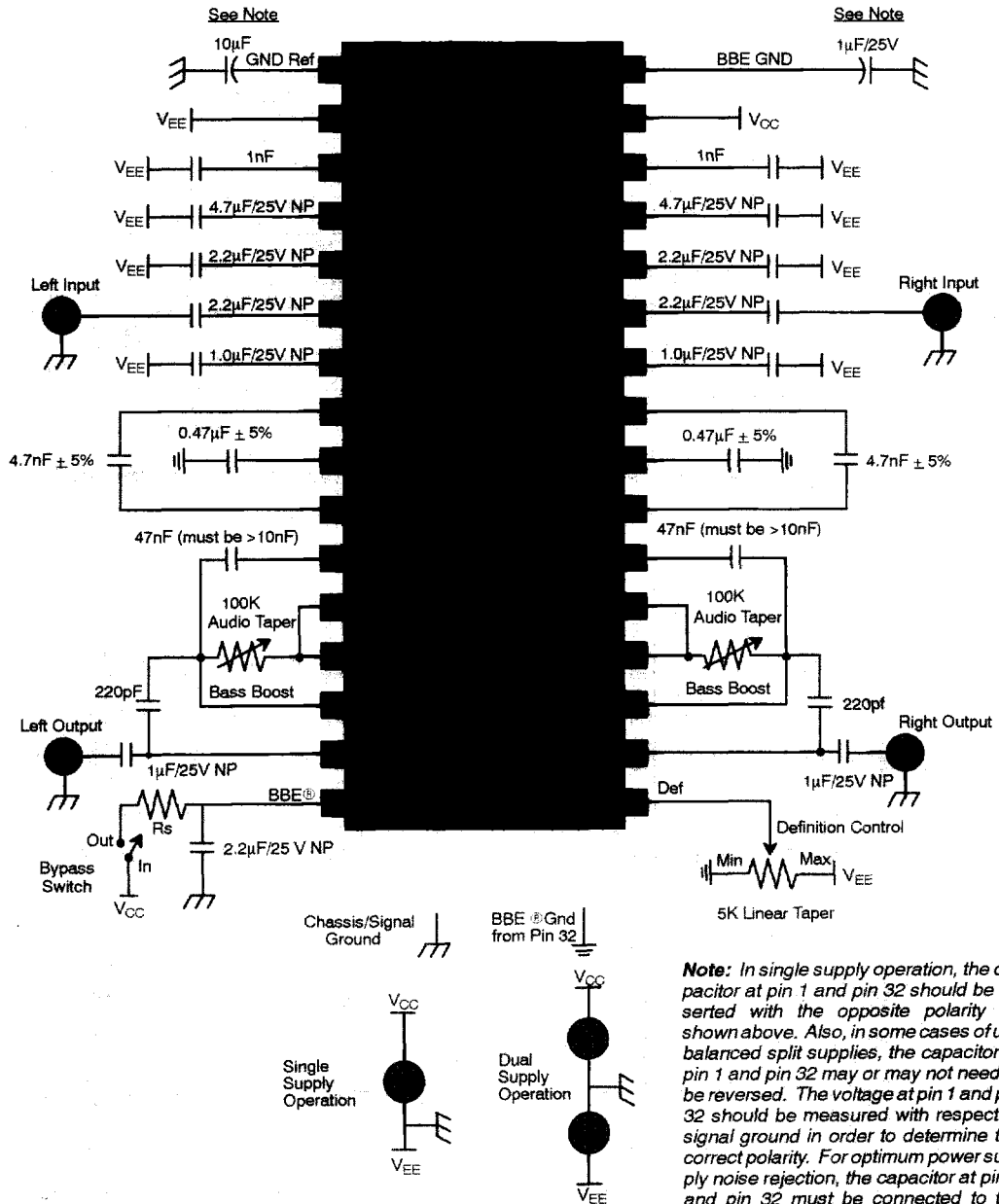

Figure 7. Typical Application Schematic (DIP Package)