



050-358

PRODUCT BRIEF
SMPTE HD-SDI AND 3G-SDI*
PC BOARD MOUNT DUAL-TRANSMITTER
Two (2) CWDM TRANSMITTERS
SMALL & COMPACT WITH RUGGED CONSTRUCTION FOR
HARSH ENVIRONMENTS

REV	DESCRIPTION	DATE	APPROVED
2	Preliminary	06/15/2015	SZ
3	Add ECCN	05/26/2016	RAS
4	Removed 3G-SDI	07/07/2016	RAS
5	Edit Bag and Tag Labeling	12/13/2016	RAS/GC
6	Remove incorrect reference to ATMEL AT240C01A, added optional I2C addressing	02/28/2017	RAS/GC
7	Remove reference to 3G-SDI	05/23/2017	RAS/GC
8	Add 3G-SDI option	07/06/2017	RAS/SZ/GC
9	Update maximum operating current	07/12/2018	RAS/SZ/GC
10	Increase Output Power limit	09/04/2018	RAS/SZ
11	Update pictures	09/26/2018	RAS/GC

BF15U2-3100

THIS COPYRIGHTED DOCUMENT IS THE PROPERTY OF GLENAIR, INC. AND IS FURNISHED ON THE CONDITION THAT IT IS NOT TO BE DISCLOSED, REPRODUCED IN WHOLE OR IN PART, OR USED TO SOLICIT QUOTATIONS FROM COMPETITIVE SOURCES, OR USED FOR MANUFACTURE BY ANYONE OTHER THAN GLENAIR, INC. WITHOUT WRITTEN PERMISSION FROM GLENAIR, INC. THE INFORMATION HEREIN HAS BEEN DEVELOPED AT GLENAIR'S EXPENSE AND MAY BE USED FOR ENGINEERING EVALUATION AND INCORPORATION INTO TECHNICAL SPECIFICATIONS AND OTHER DOCUMENTS WHICH SPECIFY PROCUREMENT OF PRODUCTS FROM GLENAIR, INC.

050-358 PRODUCT BRIEF
PC Board Mount Dual-Transmitter
HD-SDI, SMF, 3.3V



PCB Mount CWDM Fiber Optic Dual-Transmitter, HD-SDI & 3G-SDI*, SMF, 3.3V

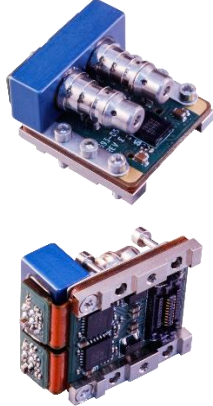

Glenair 050-358, is a ruggedized harsh environment PC Board Mount Dual-transmitter with electrical and optical functionality similar to transmitters in SFP transceivers but with mechanical design that is suited to the harsh temperature and vibration environments found in Military, Aerospace, Railway, Oil and Gas, and Industrial applications. The board mount optical dual-transmitters also support Digital Monitoring Interface (DMI) features in accordance with SFF 8472. The dual-transmitter interfaces with a host board through a high speed electrical connector.

Each transmitter includes a Transmitter Optical Subassembly (TOSA) and laser driver circuitry. The TOSA incorporates ITU CWDM wavelength DFB lasers to convert electrical signals to fiber optic signals; the output of the TOSA mates with the GC optical connector. This laser driver circuit regulates the optical power at a constant level provided the data pattern is relatively DC balanced and can support SMPTE EG 34:2004 Pathological conditions CASE 1, CASE2, and CASE 3 for HD-SDI and 3G-SDI*.

KEY FEATURES/BENEFITS

- SMPTE EG 34:2004 Compliant to Pathological Conditions CASE 1, CASE 2 and CASE 3.
- SMPTE ST 297:2006 (HD-SDI & 3G-SDI*)
- SMPTE 292 Compliant (HD-SDI)
- SMPTE 424 Compliant (3G-SDI*)
- SFP Compatible Electrical Input signal levels
- CWDM DFB Lasers to support HD-SDI
- Glenair Rugged GC Optical connector withstand high shock and vibration
- Dual-transmitter is securely mounted with screws to PCB to ensure excellent shock and vibration performance
- High-Speed Electrical plug-in connector eliminates the need for soldering & enables ease of servicing
- Captive screws to simplify assembly operations
- Compact size: ~ 0.8" x 0.9" x 0.5"
- -40°C to +85°C Operating Case Temperature
- Glenair fiber jumpers, FA02454, connect from dual-transmitter to any Glenair Mil/Aero Fiber Optic Connector
- Evaluation fixtures available
- Digital Diagnostic and Monitoring (DMI) based on SFF-8472, enables monitoring of:
 - TX optical power for each channel, Laser bias current, Temperature, Supply Voltage

APPLICATIONS

- Harsh Environment such as: Airborne, Tactical, Railway, Industrial, Oil and Gas and Shipboard applications
 - SMPTE HD-SDI & 3G-SDI* Video Applications

Part Number	Two Wire Address	Data Rate	TX #1 Wavelength	TX #2 Wavelength	Screw Length (Mod Code)
050-358	Blank = A2h, A4h	-1D = HD-SDI	-27 = 1271nm	27 = 1271nm	Blank = Standard
PCB Mount CWDM Dual-Transmitter, SMF	Other Options: See Table 1A	-2D = 3G-SDI*	-29 = 1291nm -31 = 1311nm -33 = 1331nm -35 = 1351nm -37 = 1371nm -39 = 1391nm -41 = 1411nm	29 = 1291nm 31 = 1311nm 33 = 1331nm 35 = 1351nm 37 = 1371nm 39 = 1391nm 41 = 1411nm	-954-xxx – IAW Mod Code 954

Example: **050-358C2-1D-2729**

PCB Mount CWDM Dual-Transmitter, SMF, 1271nm & 1291nm, Two Wire Address = C2h & C4h, Data Rate = HD-SDI
 Standard Temperature Range, Standard Screw Length

*5dB reduction in 3G-SDI Optical Link Budget (See Ratings and Specifications)

**Temperature and Screw Length Mod Codes will not be added onto Digital Memory ID (See Table 9)

050-358 PRODUCT BRIEF
PC Board Mount Dual-Transmitter
HD-SDI, SMF, 3.3V



TABLE 1A TWO WIRE ADDRESS –IDENTIFIER OPTIONS

PN Identifier	Transceiver #1 Address	Transceiver #2 Address
Blank	A2h	A4h
A6	A6h	A8h
B2	B2h	B4h
B6	B6h	B8h
C2	C2h	C4h
C6	C6h	C8h
D2	D2h	D4h
D6	D6h	D8h
E2	E2h	E4h
E6	E6h	E8h

Contact Glenair if additional addresses required

050-358 PRODUCT BRIEF
PC Board Mount Dual-Transmitter
HD-SDI, SMF, 3.3V



Ratings and Specifications

TABLE 2 ABSOLUTE MAXIMUM RATINGS

Parameter	Symbol	Min	Typ	Max	Units	Notes
Storage Temperature	T _s	-55		+100	°C	
Supply Voltage	V _{cc}	-0.4		3.8	V	V _{ccT} may not differ by more than 0.5V

TABLE 3 OPERATING CONDITIONS

Parameter	Symbol	Min	Typ	Max	Units	Notes
Operating Temperature, Case	T _{op}	-40		+85	°C	
Supply Voltage	V _{cc}	3.135	3.3	3.465	V	
Supply Current	I _{cc}		200	300	mA	Typical @ 85°C
Power Supply Noise (Peak-Peak)	V _{cc ripple}			100	mV	

TABLE 4 ELECTRO-OPTICAL CHARACTERISTICS – HD-SDI TRANSMITTER

Parameter	Symbol	Min	Typ	Max	Units	Notes
Optical Output Power	P _{OUT}	-1	1.5	+5	dBm	@ 1.485 Gbps
Extinction Ratio	E _r	5	10		dB	@ 1.485 Gbps
Optical Link Budget		19			dBm	@ 1.485 Gbps Measured in combination with 050-357 (3G-SDI Dual RX) and 050-358 (HD-SDI CWDM Dual TX), Compliant with SMPTE 292
Optical Wavelength, "27", 1271 nm	λ _{OUT}	1261	1271	1278.5	nm	
Optical Wavelength, "29", 1291 nm		1281	1291	1298.5		
Optical Wavelength, "31", 1311 nm		1301	1311	1318.5		
Optical Wavelength, "33", 1331 nm		1321	1331	1338.5		
Optical Wavelength, "35", 1350 nm		1341	1351	1358.5		
Optical Wavelength, "37", 1370 nm		1361	1371	1378.5		
Optical Wavelength, "39", 1390 nm		1381	1391	1398.5		
Optical Wavelength, "41", 1410 nm		1401	1411	1418.5		
Spectral Width, rms	Δλ			1	nm	
Side Mode Suppression Ratio	SMSR	30			dB	
Relative Intensity Noise	RIN			-117	dB/Hz	
Timing Jitter	T _J			1	UI	SMPTE 292, 1.485 Gbps, Color bar
Alignment Jitter	A _J			0.2	UI	SMPTE 292, 1.485 Gbps, Color bar
Transmitter Differential Input Impedance	R _{in}		100		Ohms	AC coupled Internally
Differential Input Voltage	V _{in_d}	250		2200	mV _{pp}	CML, 100 ohm

050-358 PRODUCT BRIEF
PC Board Mount Dual-Transmitter
HD-SDI, SMF, 3.3V



Ratings and Specifications (continued)

TABLE 5 ELECTRO-OPTICAL CHARACTERISTICS – 3G-SDI TRANSMITTER

Parameter	Symbol	Min	Typ	Max	Units	Notes
Optical Output Power	P _{OUT}	-1	1.5	+3.5	dBm	@ 2.970 Gbps*
Extinction Ratio	Er	5	10		dB	@ 2.970 Gbps*
Optical Link Budget*		11			dB	@ 2.970 Gbps* Measured in combination with 050-357 (3G-SDI Dual RX) and 050-358 (HD-SDI CWDM Dual TX)
Optical Wavelength, "27", 1271 nm	λ _{OUT}	1261	1271	1278.5	nm	
Optical Wavelength, "29", 1291 nm		1281	1291	1298.5		
Optical Wavelength, "31", 1311 nm		1301	1311	1318.5		
Optical Wavelength, "33", 1331 nm		1321	1331	1338.5		
Optical Wavelength, "35", 1350 nm		1341	1351	1358.5		
Optical Wavelength, "37", 1370 nm		1361	1371	1378.5		
Optical Wavelength, "39", 1390 nm		1381	1391	1398.5		
Optical Wavelength, "41", 1410 nm		1401	1411	1418.5		
Spectral Width, rms	Δλ			1	nm	
Side Mode Suppression Ratio	SMSR	30			dB	
Relative Intensity Noise	RIN			-117	dB/Hz	
Timing Jitter	TJ			1	UI	SMPTE 424, 2.970 Gbps, Color bar
Alignment Jitter	AJ			0.2	UI	SMPTE 424, 2.970 Gbps, Color bar
Transmitter Differential Input Impedance	R _{in}		100		Ohms	AC coupled Internally
Differential Input Voltage	V _{in_d}	250		2200	mV _{p-p}	CML, 100 ohm

*Note: Does not meet 3G-SDI optical link budget standard of 16dB. Due to bandwidth limitation, 3G-SDI optical eye diagram will experience degradation in performance, resulting in an 11dB optical link budget when measured with Glenair 050-357 (PCB Mount CWDM Dual-Receiver).

TABLE 6 COMPLIANCE SPECIFICATIONS

CHARACTERISTIC	Standard	Condition	Notes
Mechanical Shock	MIL-STD-810	Para. 516.6, proc. I, 650g	0.9 ms operating
Mechanical Vibration	MIL-STD-810	Para. 514.6, 40g rms	Random, operating
ESD	MIL-STD-883		1000V HBM
Flame Resistance	MIL-STD-1344	Method 1012, Cond. B	30 seconds
Damp Heat	MIL-STD-1344	Method 1002.2, Cond. B	10 cycles , 24 hours
Eye Safety	CDRH and IEC-825	Class 1 Laser Product	

050-358 PRODUCT BRIEF
PC Board Mount Dual-Transmitter
HD-SDI, SMF, 3.3V



Ratings and Specifications (continued)

TABLE 7 MATERIAL/FINISH

Item	Material/Finish
PCB	FR4
PCB flex	FR4 & Polyimide
Railings	Aluminum 6061-T6 per ASTM-B221/B211M or Equivalent
Screws	CRES Type, 302, 303, 304, 305, or 316
Optical Ferrules & Sleeves	Zirconia, Ceramic
Solder type	RoHS compliant Sn95/Sb5 (232°C melting temp) & RoHS compliant Sn96.5/Ag3.0/Cu0.5 (217° melting)

050-358 PRODUCT BRIEF
PC Board Mount Dual-Transmitter
HD-SDI, SMF, 3.3V



FIGURE 1 - OUTLINE DRAWING CONTINUED (MARKING)

LABELING:

Each unit will be shipped in an antistatic bag. The label on the antistatic bag shall be at a minimum Arial size 10 black font and contain at a minimum the following information:

ANTISTATIC BAG LABEL:

Glenair
Cage Code: 06324
PN: 050-358XX-XX-XXXX
Rev: X
QTY: X
J/N: X
D/C: X
S/N*: XXXXXX
*If QTY is more than 1, there is no S/N

Each unit will be marked, either with a label or laser engraving, as follows:

1. Marking font to be Arial, greater than .08 inches in height.
2. Minimum Marking on each part will include the following:
 - Glenair
 - Serial number
 - Glenair Part Number

Example Minimum Marking:

GLENAIR SN123456
050-358C2-1D-2729

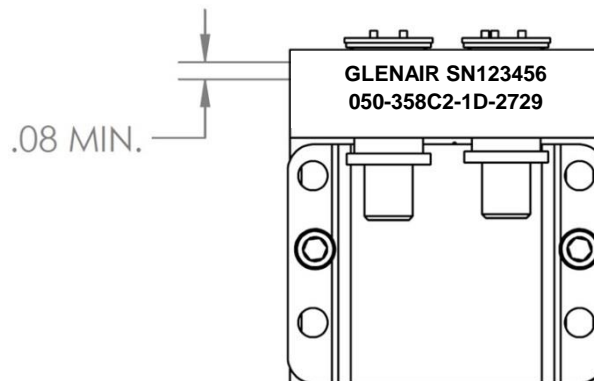

FUNCTIONAL DESCRIPTION

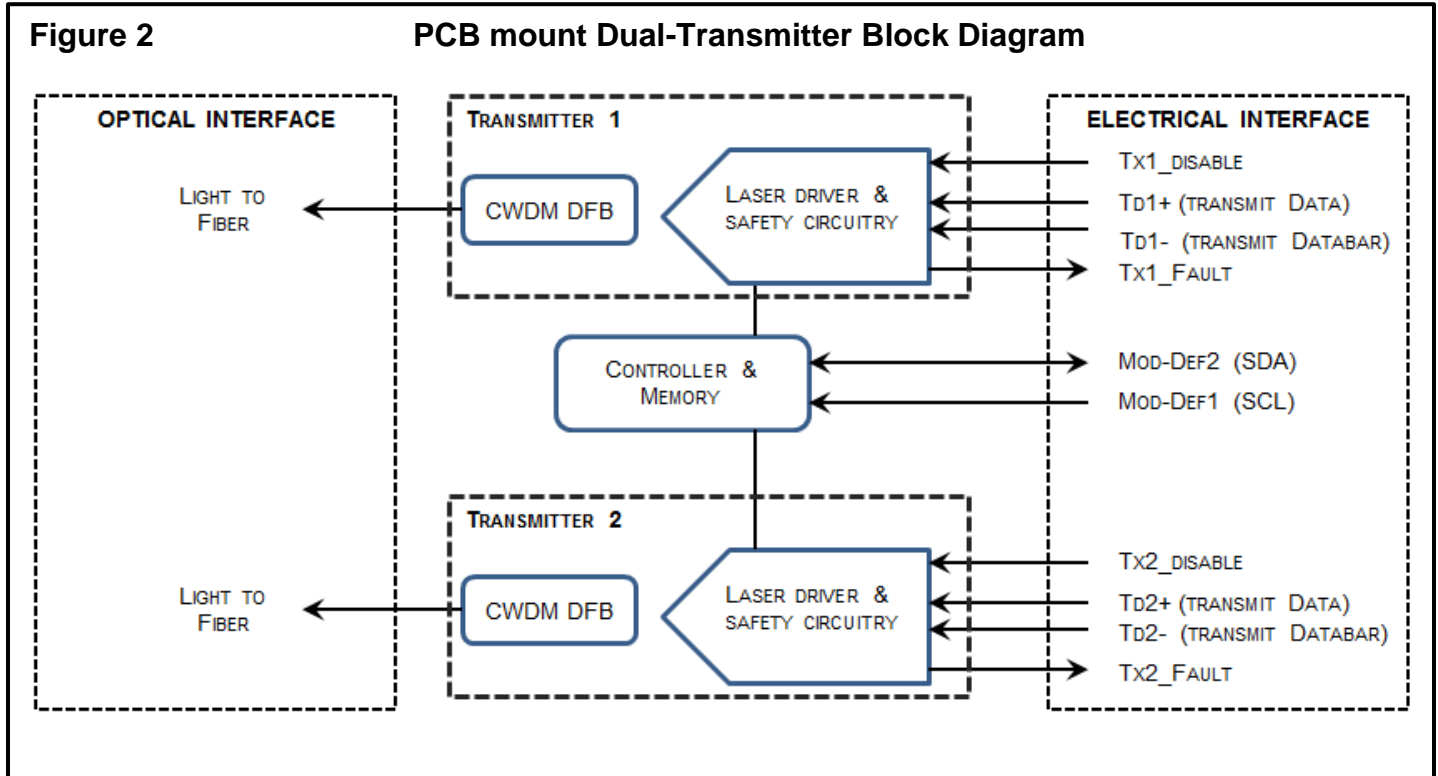

TRANSMITTER SECTION

Transmit Disable (TX1_Disable and TX2_Disable)

The transmitters accept a TTL and CMOS compatible transmit disable control signal input that shuts down the transmitter optical output. A high signal disables the transmitter while a low signal allows normal dual-transmitter operation. Also laser is disabled when TX Disable is open. In the event of a fault (e.g. eye safety circuit activated), cycling this control signal resets the module. Host systems should allow a 10ms interval between successive assertions of this control signal.

Transmit Fault (TX1_FAULT and TX2_FAULT)

A catastrophic laser fault will activate the transmitter signal, TX*_FAULT, and disable the laser. This signal is an open collector output (pull-up required on the host board). A low signal indicates normal laser operation and a high signal indicates a fault. The TX*_FAULT will be latched high when a laser fault occurs and is cleared by toggling the TX*_DISABLE input or cycling the power of the dual-transmitter. The transmitter fault condition can also be monitored via the optional 2-wire serial interface (address A2, byte 110, bit 2).

050-358 PRODUCT BRIEF
PC Board Mount Dual-Transmitter
HD-SDI, SMF, 3.3V



Eye Safety Circuit

The Transmitters provide Class 1 eye safety by design and are compliant with US FDA CDRH AEL Class 1 and EN(IEC) 60825-1,2, EN60950 Class 1. The eye safety circuit continuously monitors optical output power levels and will disable the transmitter and assert a TX_FAULT signal upon detecting an unsafe condition. Such unsafe conditions can be created by inputs from the host board (Vcc fluctuation, unbalanced code) or faults within the module.

FUNCTIONAL I/O

The PC board mount dual-transmitter accepts industry standard differential signals such as LVPECL and CML within the scope of the SFP MSA. To simplify board requirements, transmitter bias resistors and ac coupling capacitors are incorporated, per SFF-8074i, and hence are not required on the host board. The module is AC-coupled and internally terminated.

Figure 3 illustrates a recommended interface circuit to link the PC board mount dual-transmitter to the supporting Physical Layer integrated circuits.

The PC board mount dual-transmitter interfaces with the host circuit board through twenty I/O pins identified by function in Table 8. The dual-transmitter high speed transmit and receive interfaces require SFP MSA compliant signal lines on the host board. The TX1_DISABLE, TX2_DISABLE, TX1_FAULT and TX2_FAULT require TTL lines on the host board (per SFF-8074i) if used. If an application chooses not to take advantage of the functionality of these pins TX1_Disable and TX2_Disable need to be tied to GND, TX1_Fault, TX2_Fault do not need to be connected.

050-358 PRODUCT BRIEF
 PC Board Mount Dual-Transmitter
 HD-SDI, SMF, 3.3V



FIGURE 3 RECOMMENDED BOARD MOUNT DUAL-TRANSMITTER HOST BOARD SCHEMATIC

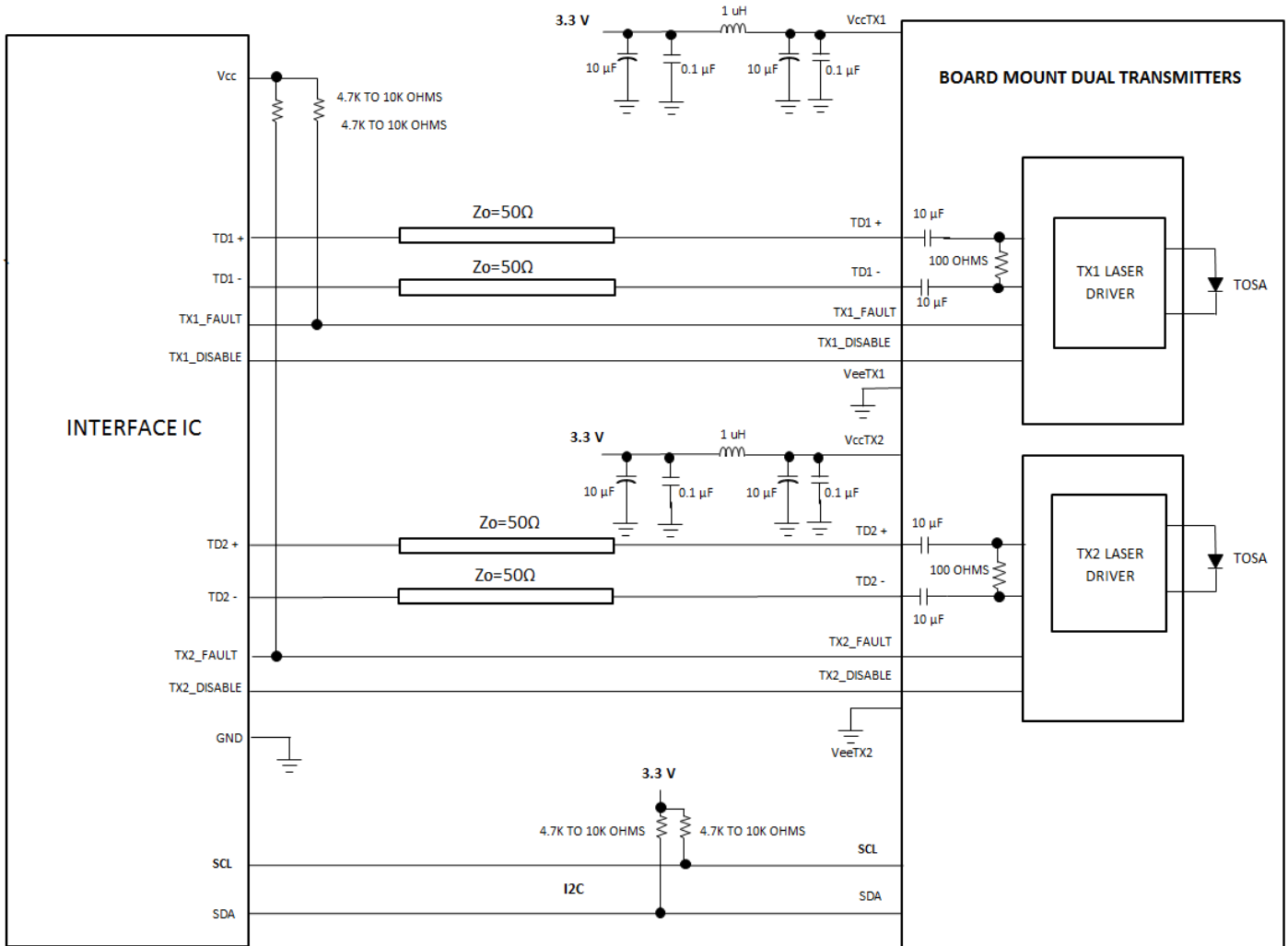

050-358 PRODUCT BRIEF
PC Board Mount Dual-Transmitter
HD-SDI, SMF, 3.3V



Digital Diagnostic Interface and Serial Identification (EEPROM)

The PCB mount Dual-Transmitter is derived from the SFF-8074i SFP specification and with SFF-8472, the SFP specification for Digital Diagnostic Monitoring Interface, but modified to account for Dual-Transmitter functionality. Both specifications can be found at <http://www.sffcommittee.org>.

FIGURE 4 – DIGITAL DIAGNOSTIC MEMORY MAP OVERVIEW

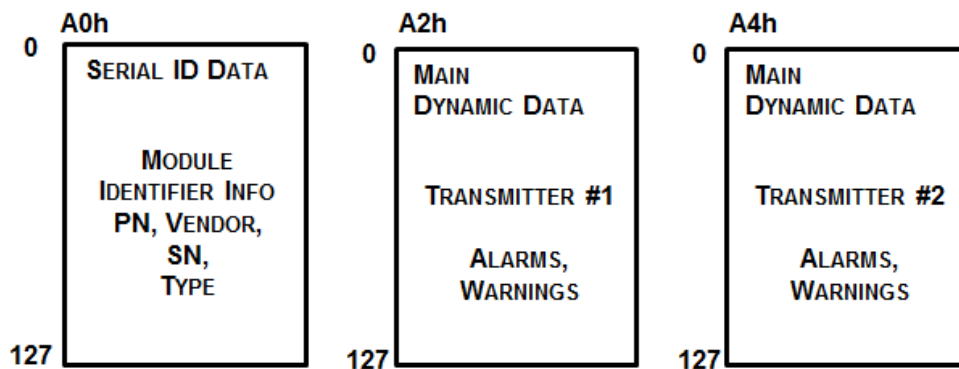

A0h (Standard Serial ID Data Address)

Other Dynamic Data Addresses available – see Part Number Development Options (Table 1 and Table 1A)

The PCB mount Dual-Transmitter features EEPROM for Serial ID, which contains the product data stored for retrieval by host equipment. This data is accessed via the 2-wire serial EEPROM protocol derived from with the industry standard SFP Multi-Source Agreement but modified to account for Dual-Transmitter functionality. The base EEPROM memory, bytes 0-255 at memory address A0h, is organized in compliance with SFF-8074i.

050-358 PRODUCT BRIEF
PC Board Mount Dual-Transmitter
HD-SDI, SMF, 3.3V



Predictive Failure Identification

The predictive failure feature allows a host to identify potential link problems before system performance is impacted. Prior identification of link problems enables a host to service an application via “fail over” to a redundant link or replace a suspect device, maintaining system uptime in the process. For applications where ultra-high system uptime is required, the PCB mount Transceiver provides a means to monitor two real-time laser metrics associated with observing laser degradation and predicting failure: average laser bias current (TX_Bias) and average laser optical power (TX_Power).

Compliance Prediction

Compliance prediction is the ability to determine if an optical transceiver is operating within its operating and environmental requirements. The PCB mount Transceiver provide real-time access to transceiver internal supply voltage and temperature, allowing a host to identify potential component compliance issues. Received optical power is also available to assess compliance of fiber cable plant and remote transmitter. When operating out of requirements, the link cannot guarantee error free transmission.

Fault Isolation

The fault isolation feature allows a host to quickly pinpoint the location of a link failure, minimizing downtime. For optical links, the ability to identify a fault at a local device, remote device or cable plant is crucial to speeding service of an installation. PCB mount Transceiver real-time monitors of TX_Bias, TX_Power, Vcc, and Temperature can be used to assess local transceiver current operating conditions.

Component Monitoring

Component evaluation is another use of the PCB mount Transceiver real-time monitors of TX_Bias, TX_Power, Vcc, and Temperature. Potential uses are as debugging aids for system installation and design, and transceiver parametric evaluation for factory or field qualification. For example, temperature per module can be observed in high density applications to facilitate thermal evaluation of systems that incorporate this PCB mount transceiver

Required Host Board Components

A power supply noise rejection filter as describe in SFP MSA is required on the host PCB to meet data sheet performance. This is filter incorporates an inductor which should be rated to 400 mADC and 1 Ω series resistance or better. It should not be replaced with a ferrite. The required filter is illustrated in Figure 4. Also, the host PCB for the PCB mount transceiver requires 4.7 K to 10 K Ω pull-up resistors for TX_FAULT, SCA and SDL lines.

FIGURE 4 RECOMMENDED HOST BOARD POWER SUPPLY FILTERING CIRCUIT

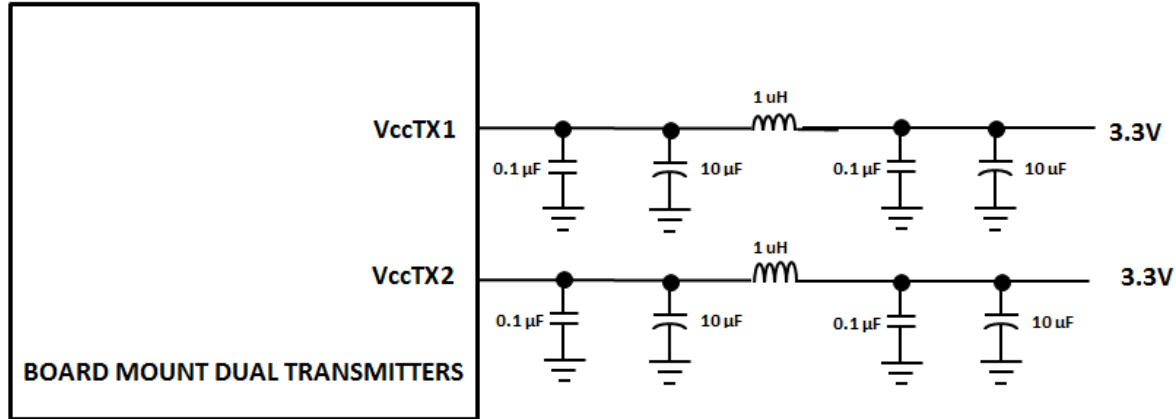

Fiber Compatibility

The transceiver is capable of transmission up to 10km with 9/125 μm fiber at 1.25Gbps data rate.

Electrostatic Discharge (ESD)

The Transceiver is compatible with ESD levels found in typical manufacturing and operating environments as described JEDEC EIA JESD22-A114-A, Class 1 (<2000Volts) HBM. Glenair recommends that devices are handled with ESD precautions to limit exposure to below 500V HBM.

There are two design cases in which immunity to ESD damage is important. The first case is during handling of the transceiver prior to insertion to the host board. To protect the transceiver, it's important to use standard industry ESD handling precautions. These precautions include using grounded wrist straps, work benches, and floor mats in ESD controlled areas. The ESD sensitivity of the Glenair PCB mount transceiver is compatible with typical industry production environments.

The second case to consider is static discharges to the exterior of the host equipment after installation, in which case the transceiver may be subject to system-level ESD requirements.

050-358 PRODUCT BRIEF
PC Board Mount Dual-Transmitter
HD-SDI, SMF, 3.3V



Application Support

To assist in the transceiver design and evaluation process, Glenair offers the following aids:

- Evaluation board & Product Manual, part number 050-329, which facilitates in the testing of the PCB mount transceiver.
- 3D Step file to support modeling of mechanical fit and routing
- PADS schematic and PCB layout library files that can be exported into customer's PCB software design program
- Applications Aid Example of PCB layout including details of high speed transmission designs

Customer Manufacturing Processes

This module is mounted with screws and interfaces with a high-speed low cost surface mount electrical connector residing on the host PC board. The PCB mount transceiver is not designed for aqueous wash, IR reflow, or wave soldering processes and should be mounted on the host board after host PC board has been through its assembly process.

050-358 PRODUCT BRIEF
PC Board Mount Dual-Transmitter
HD-SDI, SMF, 3.3V



TABLE 9 TWO-WIRE INTERFACE ID: DATA FIELDS – ADDRESS A0h

Byte Decimal	# Hex	Data Notes	Byte Decimal	# Hex	Data Notes
0	80	Glenair PCB mount Dual Transmitter	37	00	Vendor OUI (NOT USED)
1	04	Serial ID Module Definition	38	00	Vendor OUI (NOT USED)
2	80	"GC" Fiber Optic Connector	39	00	Vendor OUI (NOT USED)
3	00		40	30	"0" Vendor Part Number ASCII Character (Note 5)
4	00		41	35	"5" Vendor Part Number ASCII Character (Note 5)
5	00		42	30	"0" Vendor Part Number ASCII Character (Note 5)
6	00		43	2D	"." Vendor Part Number ASCII Character (Note 5)
7	00		44	33	"3" Vendor Part Number ASCII Character (Note 5)
8	00		45	35	"5" Vendor Part Number ASCII Character (Note 5)
9	00		46	38	"8" Vendor Part Number ASCII Character (Note 5)
10	00		47	43	"C" Vendor Part Number ASCII Character (Note 5)
11	03	NRZ	48	32	"2" Vendor Part Number ASCII Character (Note 5)
12	1E	BR	49	2D	"." Vendor Part Number ASCII Character (Note 5)
13	00		50	32	"2" Vendor Part Number ASCII Character (Note 5)
14	00		51	37	"7" Vendor Part Number ASCII Character (Note 5)
15	64	9/125 μm Fiber, 10km @ 2.97Gbps (Note 3)	52	32	"2" Vendor Part Number ASCII Character (Note 5)
16	00		53	39	"9" Vendor Part Number ASCII Character (Note 5)
17	00		54	20	" " Vendor Part Number ASCII Character (Note 5)
18	00		55	20	" " Vendor Part Number ASCII Character (Note 5)
19	00		56	20	" " Vendor REV Level ASCII Character (Note 5)
20	47	"G" Vendor NAME ASCII Character	57	20	" " Vendor REV Level ASCII Character (Note 5)
21	4C	"L" Vendor NAME ASCII Character	58	20	" " Vendor REV Level ASCII Character (Note 5)
22	45	"E" Vendor NAME ASCII Character	59	20	" " Vendor REV Level ASCII Character (Note 5)
23	4E	"N" Vendor NAME ASCII Character	60	05	Hex Byte of Laser Wavelength (Note 6)
24	41	"A" Vendor NAME ASCII Character	61	1E	Hex Byte of Laser Wavelength (Note 6)
25	49	"I" Vendor NAME ASCII Character	62		RESERVED
26	52	"R" Vendor NAME ASCII Character	63		Check sum code for ID fields 0-62 (Note 7)
27	20	" " Vendor NAME ASCII Character	64	00	
28	20	" " Vendor NAME ASCII Character	65	18	Hardware TX_Disable, TX_Fault,
29	20	" " Vendor NAME ASCII Character	66	00	
30	20	" " Vendor NAME ASCII Character	67	00	
31	20	" " Vendor NAME ASCII Character	68-83		Serial Number, ASCII (Note 8)
32	20	" " Vendor NAME ASCII Character	84-91		Date Code (Note 9)
33	20	" " Vendor NAME ASCII Character	92	68	Diagnostic Monitoring Type
34	20	" " Vendor NAME ASCII Character	93	A0	Enhanced Options
35	20	" " Vendor NAME ASCII Character	94	05	SFF-8472 rev 11.0
36	00		95		Checksum for bytes 64-94 (Note 7)
			96-255	00	

Notes:

1. RESERVED
2. RESERVED
3. Link distance with 9/125μm cable at 1.25Gbps is 10km.
4. RESERVED
5. Table 1, Part number options/extensions. Temperature, Screw Length Mod Codes, and "1D-" will not be added onto Digital Memory ID.
6. Laser wavelength is represented in 16 unsigned bits. The hex representation of 1310 nm is 051E. The hex representation of 850nm is 0352.
7. Addresses 63 and 95 are checksums calculated per SFF-8472 and SFF-8074, and stored prior to product shipment.
8. Addresses 68-83 specify the module's ASCII serial number and will vary by unit.
9. Addresses 84-91 specify the module's ASCII date code and will vary according to manufactured date-code.

050-358 PRODUCT BRIEF
PC Board Mount Dual-Transmitter
HD-SDI, SMF, 3.3V



Table 10 Two-Wire interface ID: Data Fields – Address A2h (TX1), A4h (TX2) standard (or see Table 1A for other options)
NOTE: RX Data fields are not applicable in this table (i.e. Addresses 32-39 and 104-105)

Byte # Decimal	Data Notes	Byte # Decimal	Data Notes	Byte # Decimal	Data Notes
0	Temp H Alarm MSB (Note 1)	26	TX Pwr L Alarm MSB (Note 4)	104	Reserved
1	Temp H Alarm LSB (Note 1)	27	TX Pwr L Alarm LSB (Note 4)	105	Reserved
2	Temp L Alarm MSB (Note 1)	28	TX Pwr H Warning MSB (Note 4)	106	Reserved
3	Temp L Alarm LSB (Note 1)	29	TX Pwr H Warning LSB (Note 4)	107	Reserved
4	Temp H Warning MSB (Note 1)	30	TX Pwr L Warning MSB (Note 4)	108	Reserved
5	Temp H Warning LSB (Note 1)	31	TX Pwr L Warning LSB (Note 4)	109	Reserved
6	Temp L Warning MSB (Note 1)	32	Reserved	110	Status/Control
7	Temp L Warning LSB (Note 1)	33	Reserved	111	Reserved
8	Vcc H Alarm MSB (Note 2)	34	Reserved	112	Flag Bits
9	Vcc H Alarm LSB (Note 2)	35	Reserved	113	Flag Bits
10	Vcc L Alarm MSB (Note 2)	36	Reserved	114	Reserved
11	Vcc L Alarm LSB (Note 2)	37	Reserved	115	Reserved
12	Vcc H Warning MSB (Note 2)	38	Reserved	116	Flag Bits
13	Vcc H Warning LSB (Note 2)	39	Reserved	117	Flag Bits
14	Vcc L Warning MSB (Note 2)	40-45	Reserved	118	Reserved
15	Vcc L Warning LSB (Note 2)	56-94	External Cal Constants (Note 6)	119	Reserved
16	Tx Bias H Alarm MSB (Note 3)	95	Checksum for bytes 0-94	120-122	Reserved
17	Tx Bias H Alarm LSB (Note 3)	96	Temperature MSB (Note 1)	123	Reserved
18	Tx Bias L Alarm MSB (Note 3)	97	Temperature LSB (Note 1)	124	Reserved
19	Tx Bias L Alarm LSB (Note 3)	98	Vcc MSB (Note 2)	125	Reserved
20	Tx Bias H Warning MSB (Note 3)	99	Vcc LSB (Note 2)	126	Reserved
21	Tx Bias H Warning LSB (Note 3)	100	TX Bias MSB (Note 3)	127	Reserved (Note 8)
22	Tx Bias L Warning MSB (Note 3)	101	TX Bias LSB (Note 3)	128-247	Customer Writable (Note 9)
23	Tx Bias L Warning LSB (Note 3)	102	TX Power MSB (Note 4)	248-255	Vendor Specific
24	TX Pwr H Alarm MSB (Note 4)	103	TX Power LSB (Note 4)		
25	TX Pwr H Alarm LSB (Note 4)				

Notes:

1. Temperature (Temp) is decoded as a 16 bit signed twos complement integer in increments of 1/256 °C.
2. Supply voltage (VCC) is decoded as a 16 bit unsigned integer in increments of 100 µV.
3. Laser bias current (Tx Bias) is decoded as a 16 bit unsigned integer in increments of 2 µA.
4. Transmitted average optical power (Tx Pwr) is decoded as a 16 bit unsigned integer in increments of 0.1 µW.
5. Reserved
6. Bytes 56-94 are not intended from use but have been set to default values per SFF-8472.
7. Bytes 95 is a checksum calculated (per SFF-8472) and stored prior to product shipment.
8. Byte 127 accepts a write but performs no action (reserved legacy byte).
9. Bytes 128-247 are write enabled (customer writable).

050-358 PRODUCT BRIEF
PC Board Mount Dual-Transmitter
HD-SDI, SMF, 3.3V



TABLE 11 DIGITAL DIAGNOSTIC MONITOR CHARACTERISTICS (WHEN APPLICABLE)

PARAMETER	SYMBOL	MIN.	UNITS	NOTES
Dual Transmitter Internal Temperature Accuracy	TINT	±3.0	°C	Temperature is measured internal to the Dual Transmitter and is valid from -40°C to +85 °C case temperature
Dual Transmitter internal Supply Voltage accuracy	VINT	±0.1	V	Supply voltage is measured internal to the Dual Transmitter and can, with less accuracy, be correlated to the voltage at the Vcc pin. Valid over 3.3V ±5%
Dual Transmitter Laser DC Bias Current Accuracy	IINT	±10	%	
Dual Transmitter Average Optical Output Power Accuracy	PT	±3.0	dB	Coupled into 9/125 mm SM fiber. Valid from -1dBm to -10dBm

050-358 PRODUCT BRIEF
PC Board Mount Dual-Transmitter
HD-SDI, SMF, 3.3V



ACCESSORIES

Fiber Optic Jumper Cables to support connection to Mil/Aerospace Connectors

KEY FEATURES:

- Jumper cable between Glenair Transceiver (end A) and Mil/Aero Connector termini (End B)
- Offered with either Multimode and Single Mode fibers

FIGURE 5
Fiber Optic Jumper Cable Assembly (see separate Glenair sales drawing FA02454 for details)



PCB Threaded Inserts, PN 059-0007

KEY FEATURES

- Simplifies installation of PCB mount transceivers eliminating the need for washers and nuts
- Soldered to PCB to eliminate need for handling nuts during assembly
- Existing Options to support PCB thickness from 0.03" to 0.92"
- Can support thicker PCB if required

EVALUATION Boards, PN 050-330, include

- Manual with test block diagram, schematic and
- Evaluation board PCBA
- 2 fiber optic cables (~1m, 9 µm/125 µm, GC connector to LC connector)

