

TA-DMKM



7-16 DIN Male to 4.1-9.5 DIN Male Low-PIM Adapter

Product Classification

Product Type Adapter

General Specifications

Body Style Straight

Inner Contact Plating Silver

Interface 4.1-9.5 DIN Male

Interface 2 7-16 DIN Male

Mounting Angle Straight

Outer Contact Plating Trimetal

Pressurizable No

Dimensions

Length 45 mm | 1.772 in

Diameter 34.6 mm | 1.362 in

TA-DMKM

Outline Drawing

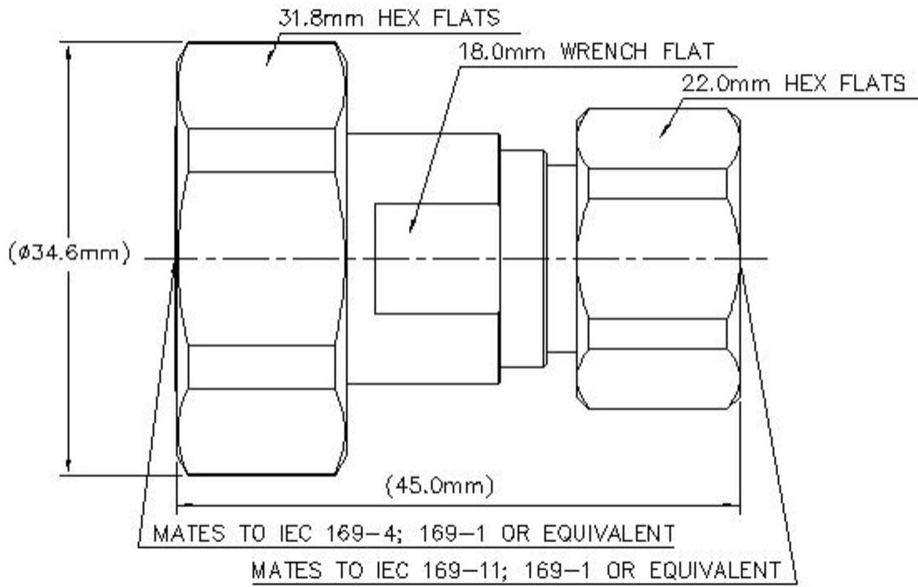

Electrical Specifications

3rd Order IMD at Frequency	-163 -dBc @ 1800 MHz
3rd Order IMD Test Method	Two +43 dBm carriers
Average Power at Frequency	1,300.0 W @ 900 MHz
Connector Impedance	50 ohm
dc Test Voltage	2500 V
Inner Contact Resistance, maximum	0.4 mOhm
Insulation Resistance, minimum	5000 MOhm
Operating Frequency Band	0 – 6000 MHz
Outer Contact Resistance, maximum	1.5 mOhm
Peak Power, maximum	28.8 kW
RF Operating Voltage, maximum (vrms)	1200 V

VSWR/Return Loss

Frequency Band	VSWR	Return Loss (dB)
0–3000 MHz	1.03	39
3000–6000 MHz	1.05	33

TA-DMKM

Mechanical Specifications

Coupling Nut Retention Force	550 N 123.645 lbf
Coupling Nut Retention Force Method	IEC 61169-16:9.3.11
Insertion Force	80 N 17.985 lbf
Insertion Force Method	IEC 61169-4:15.2.4
Interface Durability	500 cycles
Mechanical Shock Test Method	IEC 60068-2-27

Environmental Specifications

Operating Temperature	-55 °C to +85 °C (-67 °F to +185 °F)
Storage Temperature	-65 °C to +125 °C (-85 °F to +257 °F)
Attenuation, Ambient Temperature	20 °C 68 °F
Average Power, Ambient Temperature	40 °C 104 °F
Average Power, Inner Conductor Temperature	100 °C 212 °F
Climatic Sequence Test Method	IEC 60068-1
Corrosion Test Method	IEC 60068-2-11
Damp Heat Steady State Test Method	IEC 60068-2-3
Thermal Shock Test Method	IEC 60068-2-14
Vibration Test Method	IEC 60068-2-6

Packaging and Weights

Weight, net	88.3 g 0.195 lb
--------------------	-------------------

Regulatory Compliance/Certifications

Agency	Classification
CHINA-ROHS	Below maximum concentration value
ISO 9001:2015	Designed, manufactured and/or distributed under this quality management system
REACH-SVHC	Compliant as per SVHC revision on www.commscope.com/ProductCompliance
ROHS	Compliant

