

Vertical Cavity Surface Emitting Laser in TO-46 Package



OPV210, OPV210Y

Technical Data

Features

- 850nm VCSEL Technology
- High thermal stability
- Low drive current/high output density
- Narrow and concentric beam angle
- Up to 1.25 Gbps
- Recommended for multimode fiber applications
- Flat Window
- Pin out and attenuation options available on request
- Burned in for communication level reliability

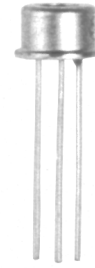

Description

The OPV210 is a high performance 850nm VCSEL packaged for high speed communication links. OPV210 combines all the performance advantages of a VCSEL with the addition of a power monitor diode for precise control of optical power.

The OPV210Y is identical electrically and optically and differs only in pin out. Refer to mechanical drawings for details.

This product's combination of features including high speed, high output power and concentric beam make it an ideal transmitter for integration into all types of data communications equipment.

Applications include:

- ◆ Fibre Channel
- ◆ Gigabit Ethernet
- ◆ ATM
- ◆ VSR (Very Short Reach)
- ◆ Intra-system links
- ◆ Optical backplane interconnects.

Absolute Maximum Ratings ($T_A = 25^\circ\text{C}$ unless otherwise noted)

Storage Temperature	-40 °C to +125 °C
Operating Temperature	-40 °C to +85 °C
Soldering Lead Temperature	260 °C for 10 Seconds
Maximum Forward Peak Current	30 mA
Maximum Reverse Voltage	5 V
Max. Continuous Optical Power at 70°C	1.1 mW



Additional laser safety information can be found on the Optek website. See application #221. Classification is not marked on the device due to space limitations. See package outline for centerline of optical radiance. Operating devices beyond maximum rating may cause devices to exceed rated classification

September 2003
Issue 3.2

OPV210, OPV210Y Technical Data



Electrical/Optical Characteristics (at 25 °C unless otherwise specified)

SYMBOL	PARAMETER	MIN	TYP	MAX	UNITS	TEST CONDITION
P_{OT}	Power Out Total	1.4		4.5	mW	$I_F = 12 \text{ mA}$
I_{TH}	Threshold Current	2.0		5.5	mA	Note 1
V_F	Forward Voltage			2.15	V	$I_F = 12 \text{ mA}$
I_R	Reverse Current, VCSEL			30	nA	$V_R = 5 \text{ V}$
R_S	Series Resistance	14		40	ohms	Note 2
η	Slope Efficiency	0.17			mW/mA	Note 3
	Linearity	0.0				Note 4
I_{RPD}	Reverse Current, photo diode			30	nA	$I_F = 0 \text{ mA}, V_R = 5 \text{ V}$
I_M	Monitor Current	30			μA	$I_F = 12 \text{ mA}, V_R = 5 \text{ V}$
λ	Wavelength	830	850	860	nm	
$\Delta\lambda$	Optical Bandwidth			0.85	nm	
θ	Beam Divergence		12		Degree	$I_F = 12 \text{ mA}$
t_r, t_f	Rise and Fall Time		200		ps	20% to 80%
N_{RI}	Relative Intensity Noise		-123		db/Hz	
$\Delta I_{TH}/\Delta T$	Temp Coefficient of Threshold Current		± 1.5		mA	0° - 70° C, Note 1
$\Delta\lambda/\Delta T$	Temp Coefficient of Wavelength		0.06		%/°C	0° - 70° C, $I_F = 12 \text{ mA}$
$\Delta V_F/\Delta T$	Temperature Coefficient for VF		-2.5		mV/°C	0° - 70° C, $I_F = 12 \text{ mA}$
$\Delta\eta/\Delta T$	Temperature Coefficient for Efficiency		-0.4		%/C	0° - 70° C, Note 3

NOTES:

- (1) Threshold Current is based on the two line intersection method specified in Telcordia GR-468-Core. Line 1 from 6 mA to 8 mA. Line 2 from 0 mA to 2 mA.
- (2) Series Resistance is the slope of the Voltage-Current line from 8 to 12 mA.
- (3) Slope efficiency, is the slope of the best fit LI line from 8 mA to 12 mA.
- (4) Using data points taken for slope efficiency above, $\Delta L/\Delta I$ shall be calculated for each adjacent pair of 0.5 mA points. The minimum shall be 0.0. (No negative values permitted).

September 2003
Issue 3.2

Optek reserves the right to make changes at any time in order to improve design and to supply the best product possible.



Output Power vs. Forward Current

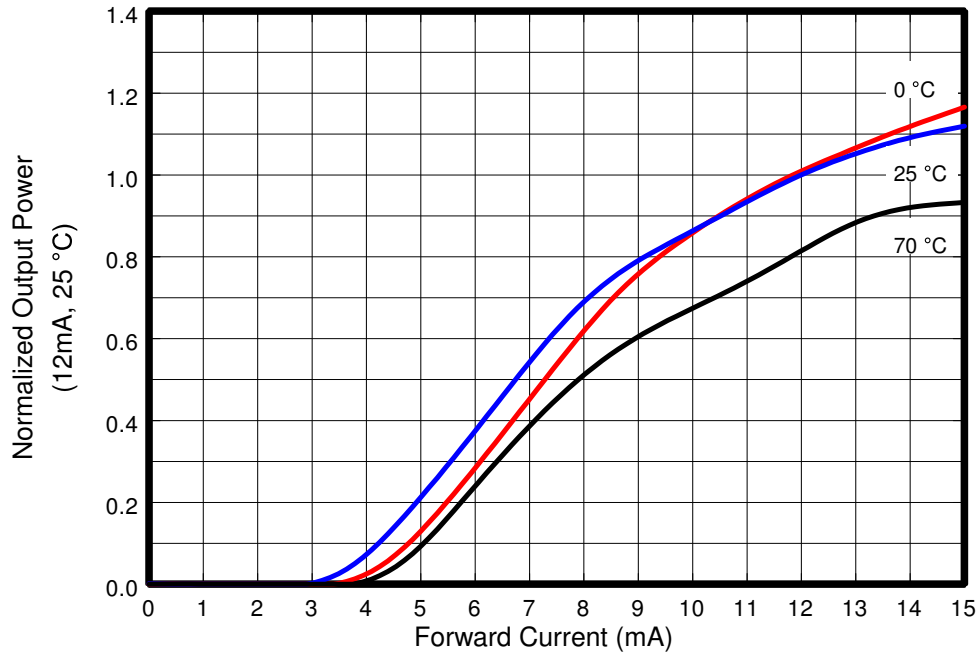

Forward Voltage vs. Forward Current

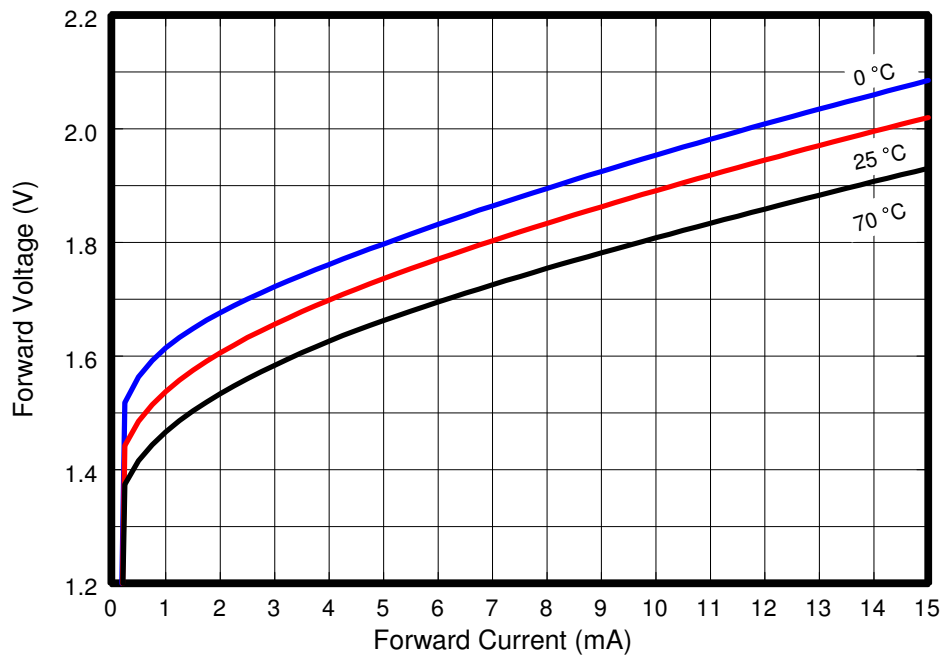

OPV210, OPV210Y Technical Data

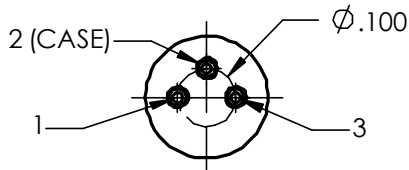
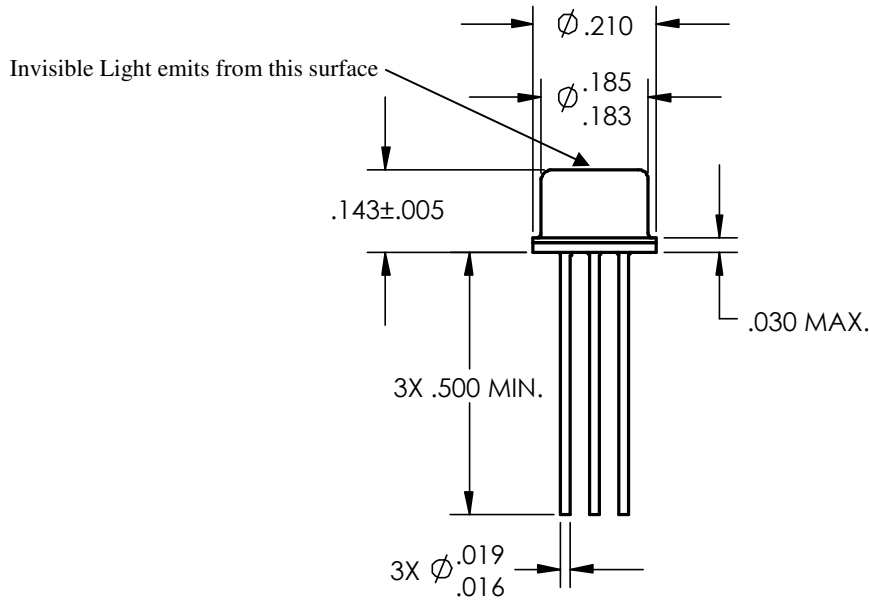

BOTTOM VIEW

- 1) Tolerances are ± 0.005 unless otherwise specified
- 2) Dimensions in inches

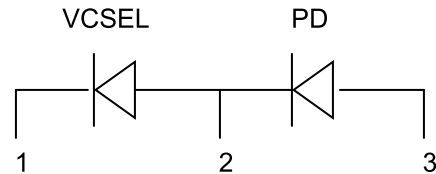
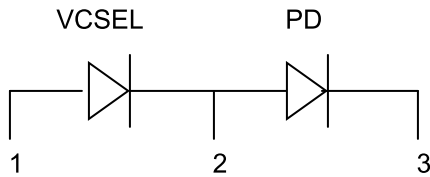

OPV210	
Pin	Connection
1	VCSEL Anode
2	VCSEL Cathode/PD Anode
3	PD Cathode

OPV210Y	
Pin	Connection
1	VCSEL Cathode
2	VCSEL Anode/PD Cathode
3	PD Anode

Optek reserves the right to make changes at any time in order to improve design and to supply the best product possible.