

3.3V 1:11 LVCMOS Zero Delay Clock Generator

The MPC93H52 is a 3.3V compatible, 1:11 PLL based clock generator targeted for high performance clock tree applications. With output frequencies up to 240 MHz and output skews lower than 200 ps the device meets the needs of most demanding clock applications.

Features

- Configurable 11 outputs LVCMOS PLL clock generator
- Fully integrated PLL
- Wide range of output clock frequency of 16.67 MHz to 240 MHz
- Multiplication of the input reference clock frequency by 3, 2, 1, 3÷2, 2÷3, 1÷3 and 1÷2
- 3.3V LVCMOS compatible
- Maximum output skew of 200 ps
- Supports zero-delay applications
- Designed for high-performance telecom, networking and computing applications
- 32 lead LQFP package
- Ambient Temperature Range — 0°C to +70°C
- Pin and function compatible to the MPC952

Functional Description

The MPC93H52 is a fully 3.3V compatible PLL clock generator and clock driver. The device has the capability to generate output clock signals of 16.67 to 240 MHz from external clock sources. The internal PLL optimized for its frequency range and does not require external look filter components. One output of the MPC93H52 has to be connected to the PLL feedback input FB_IN to close the external PLL feedback path. The output divider of this output setting determines the PLL frequency multiplication factor. This multiplication factor, F_RANGE and the reference clock frequency must be selected to situate the VCO in its specified lock range. The frequency of the clock outputs can be configured individually for all three output banks by the FSELx pins supporting systems with different but phase-aligned clock frequencies.

The PLL of the MPC93H52 minimizes the propagation delay and therefore supports zero-delay applications. All inputs and outputs are LVCMOS compatible. The outputs are optimized to drive parallel terminated 50Ω transmission lines. Alternatively, each output can drive up to two series terminated transmission lines giving the device an effective fanout of 22.

The device also supports output high-impedance disable and a PLL bypass mode for static system test and diagnosis. The MPC93H52 is package in a 32-lead LQFP.

MPC93H52

**LOW VOLTAGE
3.3V LVCMOS 1:11
CLOCK GENERATOR**



FA SUFFIX
32-LEAD LQFP PACKAGE
CASE 873A-03

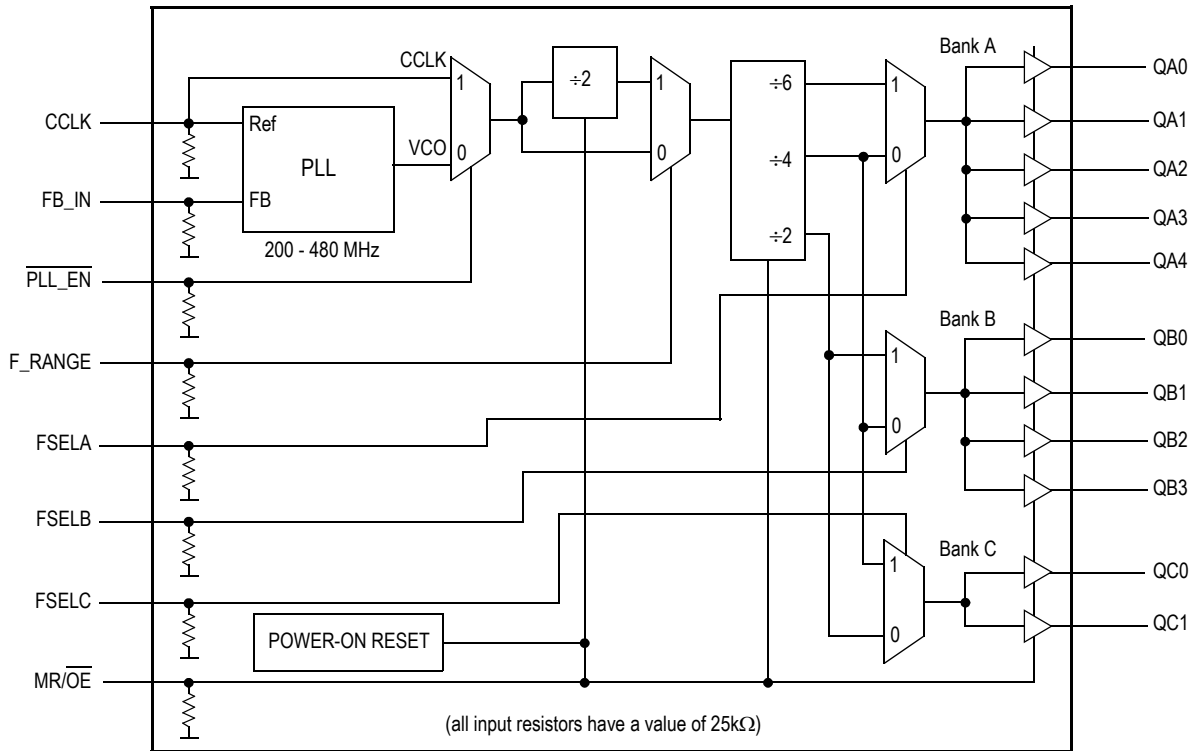
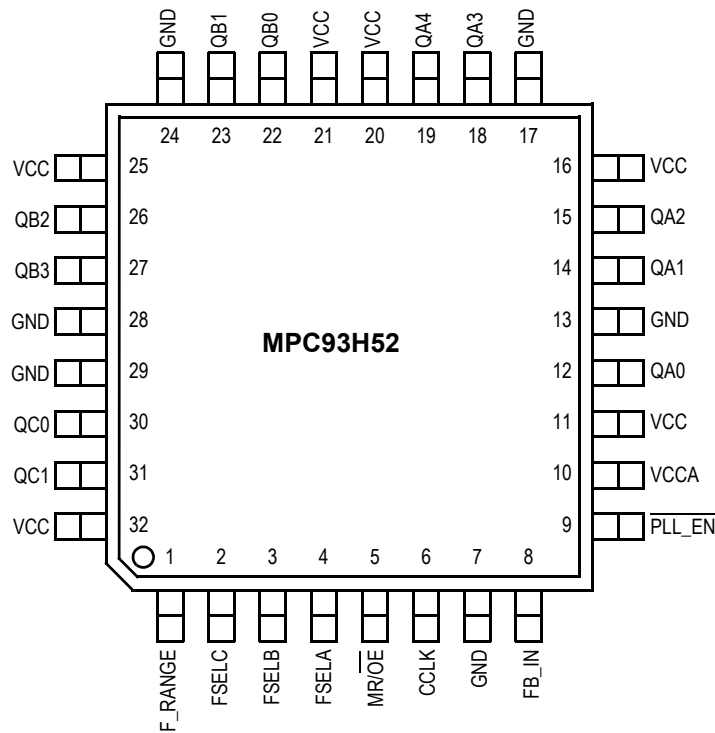

Figure 1. MPC93H52 Logic Diagram



It is recommended to use an external RC filter for the analog power supply pin VCCA. Please see application section for details.

Figure 2. MPC93H52 32-Lead Package Pinout (Top View)

Table 1. PIN CONFIGURATION

Pin	I/O	Type	Function
CCLK	Input	LVC MOS	PLL reference clock signal
FB_IN	Input	LVC MOS	PLL feedback signal input, connect to an output
F_RANGE	Input	LVC MOS	PLL frequency range select
FSELA	Input	LVC MOS	Frequency divider select for bank A outputs
FSELB	Input	LVC MOS	Frequency divider select for bank B outputs
FSELC	Input	LVC MOS	Frequency divider select for bank C outputs
PLL_EN	Input	LVC MOS	PLL enable/disable
MR/OE	Input	LVC MOS	Output enable/disable (high-impedance tristate) and device reset
QA0-4, QB0-3, QC0-1	Output	LVC MOS	Clock outputs
GND	Supply	Ground	Negative power supply
VCCA	Supply	VCC	PLL positive power supply (analog power supply). It is recommended to use an external RC filter for the analog power supply pin V _{CCA} . Please see applications section for details.
VCC	Supply	VCC	Positive power supply for I/O and core

Table 2. FUNCTION TABLE

Control	Default	0	1
F_RANGE, FSELA, FSELB, and FSELC control the operating PLL frequency range and input/output frequency ratios. See Table 1 and Table 2 for supported frequency ranges and output to input frequency ratios.			
F_RANGE	0	VCO ÷ 1 (High input frequency range)	VCO ÷ 2 (Low input frequency range)
FSELA	0	Output divider ÷ 4	Output divider ÷ 6
FSELB	0	Output divider ÷ 4	Output divider ÷ 2
FSELC	0	Output divider ÷ 2	Output divider ÷ 4
MR/OE	0	Outputs enabled (active)	Outputs disabled (high-impedance state) and reset of the device. During reset, the PLL feedback loop is open and the VCO is operating at its lowest frequency. The MPC93H52 requires reset after any loss of PLL lock. Loss of PLL lock may occur when the external feedback path is interrupted. The length of the reset pulse should be greater than two reference clock cycles (CCLK). The device is reset by the internal power-on reset (POR) circuitry during power-up.
PLL_EN	0	Normal operation mode with PLL enabled.	Test mode with PLL disabled. CCLK is substituted for the internal VCO output. MPC93H52 is fully static and no minimum frequency limit applies. All PLL related AC characteristics are not applicable.

Table 3. GENERAL SPECIFICATIONS

Symbol	Characteristics	Min	Typ	Max	Unit	Condition
V_{TT}	Output Termination Voltage		$V_{CC} \div 2$		V	
MM	ESD (Machine Model)	200			V	
HBM	ESD (Human Body Model)	2000			V	
LU	Latch-Up Immunity	200			mA	
C_{PD}	Power Dissipation Capacitance		10		pF	Per output
C_{IN}	Input Capacitance		4.0		pF	Inputs

Table 4. ABSOLUTE MAXIMUM RATINGS^a

Symbol	Characteristics	Min	Max	Unit	Condition
V_{CC}	Supply Voltage	-0.3	3.9	V	
V_{IN}	DC Input Voltage	-0.3	$V_{CC}+0.3$	V	
V_{OUT}	DC Output Voltage	-0.3	$V_{CC}+0.3$	V	
I_{IN}	DC Input Current		± 20	mA	
I_{OUT}	DC Output Current		± 50	mA	
T_S	Storage Temperature	-65	125	°C	

a. Absolute maximum continuous ratings are those maximum values beyond which damage to the device may occur. Exposure to these conditions or conditions beyond those indicated may adversely affect device reliability. Functional operation at absolute-maximum-rated conditions is not implied.

Table 5. DC CHARACTERISTICS ($V_{CC} = 3.3 \text{ V} \pm 5\%$, $T_A = 0^\circ \text{ to } 70^\circ \text{C}$)

Symbol	Characteristics	Min	Typ	Max	Unit	Condition
V_{IH}	Input High Voltage	2.0		$V_{CC} + 0.3$	V	LVC MOS
V_{IL}	Input Low Voltage			0.8	V	LVC MOS
V_{OH}	Output High Voltage	2.4			V	$I_{OH} = -24 \text{ mA}^a$
V_{OL}	Output Low Voltage			0.55 0.30	V V	$I_{OL} = 24 \text{ mA}$ $I_{OL} = 12 \text{ mA}$
Z_{OUT}	Output Impedance		7 – 10		Ω	
I_{IN}	Input Current ^b			± 200	μA	$V_{IN} = V_{CC}$ or $V_{IN} = \text{GND}$
I_{CCA}	Maximum PLL Supply Current		8	12	mA	V_{CCA} Pin
I_{CCQ}^c	Maximum Quiescent Supply Current		10	16	mA	All V_{CC} Pins

a. The MPC93H52 is capable of driving 50Ω transmission lines on the incident edge. Each output drives one 50Ω parallel terminated transmission line to a termination voltage of V_{TT} . Alternatively, the device drives up to two 50Ω series terminated transmission lines.

b. Inputs have pull-down resistors affecting the input current.

c. I_{CCQ} is the DC current consumption of the device with all outputs open in high impedance state and the inputs in its default state or open.

Table 6. AC CHARACTERISTICS ($V_{CC} = 3.3\text{ V} \pm 5\%$, $T_A = 0^\circ$ to 70°C)^a

Symbol	Characteristics	Min	Typ	Max	Unit	Condition
f_{ref}	Input reference frequency in PLL mode ^{b c}	$\div 4$ feedback		120.0	MHz	
		$\div 6$ feedback	50.0	80.0	MHz	
		$\div 8$ feedback	33.3	60.0	MHz	
		$\div 12$ feedback	25.0	40.0	MHz	
	Input reference frequency in PLL bypass mode ^d	16.67	50.0	250.0	MHz	
f_{VCO}	VCO lock frequency range ^e	200		480	MHz	
f_{MAX}	Output Frequency	$\div 2$ output ^f	100	240	MHz	
		$\div 4$ output	50	120	MHz	
		$\div 6$ output	33.3	80	MHz	
		$\div 8$ output	25	60	MHz	
		$\div 12$ output	16.67	40	MHz	
$t_{P_{WMIN}}$	Minimum Reference Input Pulse Width	2.0			ns	
t_r, t_f	CCLK Input Rise/Fall Time ^g			1.0	ns	0.8 to 2.0V
$t_{(\phi)}$	Propagation Delay CCLK to FB_IN ($f_{ref} = 50\text{MHz}$) (static phase offset)	-200		+200	ps ps	PLL locked
$t_{sk(O)}$	Output-to-output Skew ^h all outputs, any frequency within QA output bank within QB output bank within QC output bank			300	ps	
				200	ps	
				200	ps	
				100	ps	
DC	Output duty cycle	45	50	55	%	
t_r, t_f	Output Rise/Fall Time	0.1		1.0	ns	0.55 to 2.4V
$t_{PLZ, HZ}$	Output Disable Time			8	ns	
$t_{PZL, LZ}$	Output Enable Time			10	ns	
$t_{JIT(CC)}$	Cycle-to-cycle jitter	output frequencies mixed		150	ps	RMS
		all outputs same frequency		25	ps	RMS
$t_{JIT(PER)}$	Period Jitter	output frequencies mixed		75	ps	RMS
		all outputs same frequency		20	ps	RMS
$t_{JIT(\phi)}$	I/O Phase Jitter ⁱ	$\div 4$ feedback divider RMS (1σ)		40	ps	
		$\div 6$ feedback divider RMS (1σ)		40	ps	
		$\div 8$ feedback divider RMS (1σ)		40	ps	
		$\div 12$ feedback divider RMS (1σ)		40	ps	
BW	PLL closed loop bandwidth ^j	$\div 4$ feedback		2.0-8.0	MHz	
		$\div 6$ feedback		1.0-4.0	MHz	
		$\div 8$ feedback		0.8-2.5	MHz	
		$\div 12$ feedback		0.6-1.5	MHz	
t_{LOCK}	Maximum PLL Lock Time			10	ms	

- a. AC characteristics apply for parallel output termination of 50Ω to V_{TT}
- b. PLL mode requires $PLL_EN=0$ to enable the PLL and zero-delay operation.
- c. The PLL may be unstable with a divide by 2 feedback ratio.
- d. In PLL bypass mode, the MPC93H52 divides the input reference clock.
- e. The input frequency f_{ref} on CCLK must match the VCO frequency range divided by the feedback divider ratio FB: $f_{ref} = f_{VCO} \div FB$.
- f. See Table 7 and Table 8 for output divider configurations.
- g. The MPC93H52 will operate with input rise and fall times up to 3.0 ns, but the AC characteristics, specifically $t_{(\phi)}$, can only be guaranteed if t_r/t_f are within the specified range.
- h. See application section for part-to-part skew calculation.
- i. See application section for a jitter calculation for other confidence factors than 1σ .
- j. -3 dB point of PLL transfer characteristics.

APPLICATIONS INFORMATION

Programming the MPC93H52

The MPC93H52 supports output clock frequencies from 16.67 to 240 MHz. Different feedback and output divider configurations can be used to achieve the desired input to output frequency relationship. The feedback frequency and divider should be used to situate the VCO in the frequency lock range between 200 and 480 MHz for stable and optimal operation. The FSELA, FSELB,

FSELC pins select the desired output clock frequencies. Possible frequency ratios of the reference clock input to the outputs are 1:1, 1:2, 1:3, 3:2 as well as 2:3, 3:1 and 2:1. Table 1 illustrates the various output configurations and frequency ratios supported by the MPC93H52. See also Table 7, Table 8 and Figure 3 to Figure 6 for further reference. A $\div 2$ output divider cannot be used for feedback.

Table 7. MPC93H52 Example Configuration (F_RANGE = 0)

PLL Feedback	fref ^a [MHz]	FSELA	FSELB	FSELC	QA[0:4]:fref ratio	QB[0:3]:fref ratio	QC[0:1]:fref ratio
VCO $\div 4$ ^b	50-120	0	0	0	fref (50-120 MHz)	fref (50-120 MHz)	fref $\cdot 2$ (100-240 MHz)
		0	0	1	fref (50-120 MHz)	fref (50-120 MHz)	fref (50-120 MHz)
		1	0	0	fref $\cdot 2\div 3$ (33-80 MHz)	fref (50-120 MHz)	fref $\cdot 2$ (100-240 MHz)
		1	0	1	fref $\cdot 2\div 3$ (33-80 MHz)	fref (50-120 MHz)	fref (50-120 MHz)
VCO $\div 6$ ^c	33.3-80	1	0	0	fref (33-80 MHz)	fref $\cdot 3\div 2$ (50-120 MHz)	fref $\cdot 3$ (100-240 MHz)
		1	0	1	fref (33-80 MHz)	fref $\cdot 3\div 2$ (50-120 MHz)	fref $\cdot 3\div 2$ (50-120 MHz)
		1	1	0	fref (33-80 MHz)	fref $\cdot 3$ (100-240 MHz)	fref $\cdot 3$ (100-240 MHz)
		1	1	1	fref (33-80 MHz)	fref $\cdot 3$ (100-240 MHz)	fref $\cdot 3\div 2$ (50-120 MHz)

a. fref is the input clock reference frequency (CCLK)

b. fref is the input clock reference frequency (CCLK)

c. fref is the input clock reference frequency (CCLK)

Table 8. MPC93H52 Example Configurations (F_RANGE = 1)

PLL Feedback	fref ^a [MHz]	FSELA	FSELB	FSELC	QA[0:4]:fref ratio	QB[0:3]:fref ratio	QC[0:1]:fref ratio
VCO $\div 8$ ^b	25-60	0	0	0	fref (25-60 MHz)	fref (25-60 MHz)	fref $\cdot 2$ (50-120 MHz)
		0	0	1	fref (25-60 MHz)	fref (25-60 MHz)	fref (25-60 MHz)
		1	0	0	fref $\cdot 2\div 3$ (16-40 MHz)	fref (25-60 MHz)	fref $\cdot 2$ (50-120 MHz)
		1	0	1	fref $\cdot 2\div 3$ (16-40 MHz)	fref (25-60 MHz)	fref (25-60 MHz)
VCO $\div 12$ ^c	16.67-40	1	0	0	fref (16-40 MHz)	fref $\cdot 3\div 2$ (25-60 MHz)	fref $\cdot 3$ (50-120 MHz)
		1	0	1	fref (16-40 MHz)	fref $\cdot 3\div 2$ (25-60 MHz)	fref $\cdot 3\div 2$ (25-60 MHz)
		1	1	0	fref (16-40 MHz)	fref $\cdot 3$ (50-120 MHz)	fref $\cdot 3$ (50-120 MHz)
		1	1	1	fref (16-40 MHz)	fref $\cdot 3$ (50-120 MHz)	fref $\cdot 3\div 2$ (25-60 MHz)

a. fref is the input clock reference frequency (CCLK)

b. QAx connected to FB_IN and FSELA=0

c. QAx connected to FB_IN and FSELA=1

Example Configurations for the MPC93H52

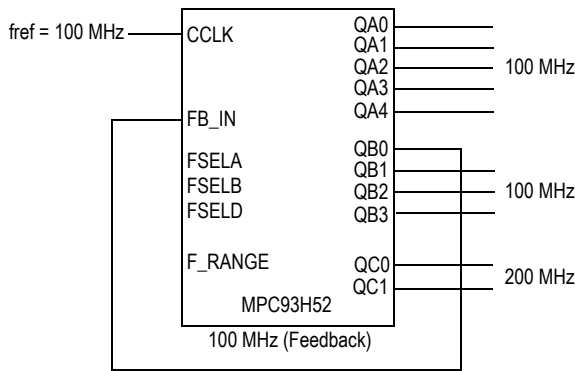

MPC93H52 default configuration (feedback of QB0 = 100 MHz). All control pins are left open.

Frequency range	Min	Max
Input	50 MHz	120 MHz
QA outputs	50 MHz	120 MHz
QB outputs	50 MHz	120 MHz
QC outputs	100 MHz	240 MHz

Figure 3. MPC93H52 Default Configuration

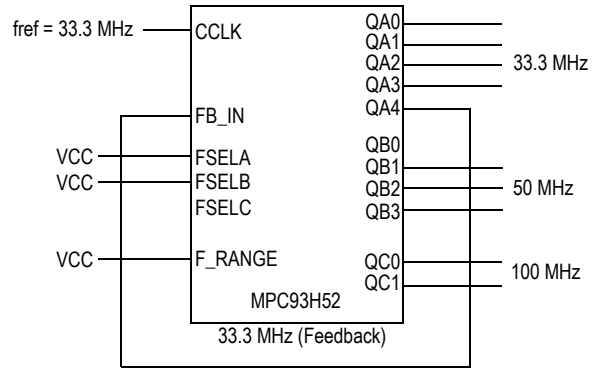

MPC93H52 configuration to multiply the reference frequency by 3, 3² and 1. PLL feedback of QA4 = 33.3 MHz.

Frequency range	Min	Max
Input	25 MHz	60 MHz
QA outputs	50 MHz	120 MHz
QB outputs	50 MHz	120 MHz
QC outputs	100 MHz	240 MHz

Figure 5. MPC93H52 Default Configuration

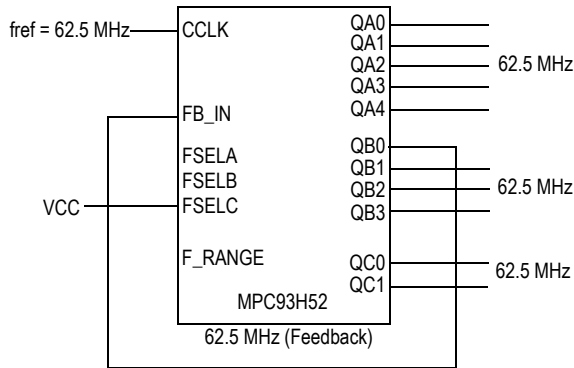

MPC93H52 zero-delay (feedback of QB0 = 62.5 MHz). All control pins are left open except FSEL C = 1. All outputs are locked in frequency and phase to the input clock.

Frequency range	Min	Max
Input	50 MHz	120 MHz
QA outputs	50 MHz	120 MHz
QB outputs	50 MHz	120 MHz
QC outputs	50 MHz	120 MHz

Figure 4. MPC93H52 Zero Delay Buffer Configuration

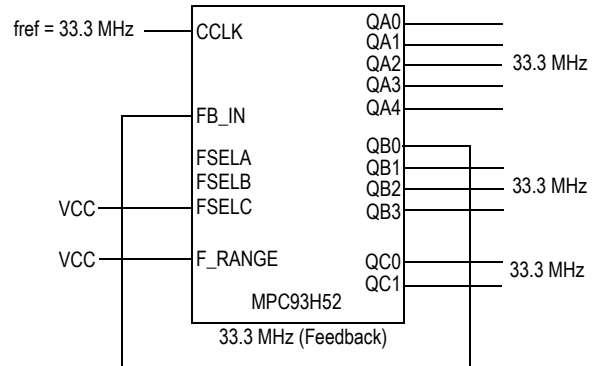

MPC93H52 zero-delay (feedback of QB0 = 33.3 MHz). Equivalent to Table 2 except F_RANGE = 1 enabling a lower input and output clock frequency.

Frequency range	Min	Max
Input	25 MHz	60 MHz
QA outputs	25 MHz	60 MHz
QB outputs	25 MHz	60 MHz
QC outputs	25 MHz	60 MHz

Figure 6. MPC93H52 Zero Delay Buffer Configuration 2

Power Supply Filtering

The MPC93H52 is a mixed analog/digital product. Its analog circuitry is naturally susceptible to random noise, especially if this noise is seen on the power supply pins. Random noise on the V_{CCA} (PLL) power supply impacts the device characteristics, for instance I/O jitter. The MPC93H52 provides separate power supplies for the output buffers (V_{CC}) and the phase-locked loop (V_{CCA}) of the device. The purpose of this design technique is to isolate the high switching noise digital outputs from the relatively sensitive internal analog phase-locked loop. In a digital system environment where it is more difficult to minimize noise on the power supplies a second level of isolation may be required. The simple but effective form of isolation is a power supply filter on the V_{CCA} pin for the MPC93H52. Figure 7 illustrates a typical power supply filter scheme. The MPC93H52 frequency and phase stability is most susceptible to noise with spectral content in the 100kHz to 20MHz range. Therefore the filter should be designed to target this range. The key parameter that needs to be met in the final filter design is the DC voltage drop across the series filter resistor R_F . From the data sheet the I_{CCA} current (the current sourced through the V_{CCA} pin) is typically 8 mA (12 mA maximum), assuming that a minimum of 2.98V must be maintained on the V_{CCA} pin. The resistor R_F shown in Figure 7 “ V_{CCA} Power Supply Filter” should have a resistance of 5-25 Ω to meet the voltage drop criteria.

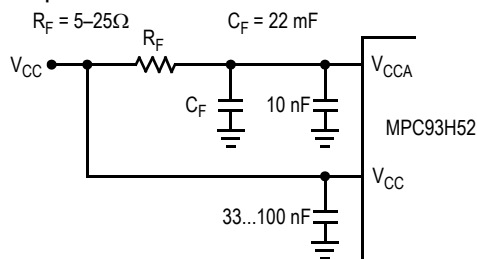

Figure 7. V_{CCA} Power Supply Filter

The minimum values for R_F and the filter capacitor C_F are defined by the required filter characteristics: the RC filter should provide an attenuation greater than 40 dB for noise whose spectral content is above 100 kHz. In the example RC filter shown in Figure 7 “ V_{CCA} Power Supply Filter”, the filter cut-off frequency is around 3-5 kHz and the noise attenuation at 100 kHz is better than 42 dB.

As the noise frequency crosses the series resonant point of an individual capacitor its overall impedance begins to look inductive and thus increases with increasing frequency. The parallel capacitor combination shown ensures that a low impedance path to ground exists for frequencies well above the bandwidth of the PLL. Although the MPC93H52 has several design features to minimize the susceptibility to power supply noise (isolated power and grounds and fully differential PLL) there still may be applications in which overall

performance is being degraded due to system power supply noise. The power supply filter schemes discussed in this section should be adequate to eliminate power supply noise related problems in most designs.

Using the MPC93H52 in zero-delay applications

Nested clock trees are typical applications for the MPC93H52. Designs using the MPC93H52 as LVCMOS PLL fanout buffer with zero insertion delay will show significantly lower clock skew than clock distributions developed from CMOS fanout buffers. The external feedback option of the MPC93H52 clock driver allows for its use as a zero delay buffer. One example configuration is to use a $\div 4$ output as a feedback to the PLL and configuring all other outputs to a divide-by-4 mode. The propagation delay through the device is virtually eliminated. The PLL aligns the feedback clock output edge with the clock input reference edge resulting a near zero delay through the device. The maximum insertion delay of the device in zero-delay applications is measured between the reference clock input and any output. This effective delay consists of the static phase offset, I/O jitter (phase or long-term jitter), feedback path delay and the output-to-output skew error relative to the feedback output.

Calculation of part-to-part skew

The MPC93H52 zero delay buffer supports applications where critical clock signal timing can be maintained across several devices. If the reference clock inputs of two or more MPC93H52 are connected together, the maximum overall timing uncertainty from the common CCLK input to any output is:

$$t_{SK(PP)} = t_{(\varnothing)} + t_{SK(O)} + t_{PD, LINE(FB)} + t_{JIT(\varnothing)} \cdot CF$$

This maximum timing uncertainty consist of 4 components: static phase offset, output skew, feedback board trace delay and I/O (phase) jitter:

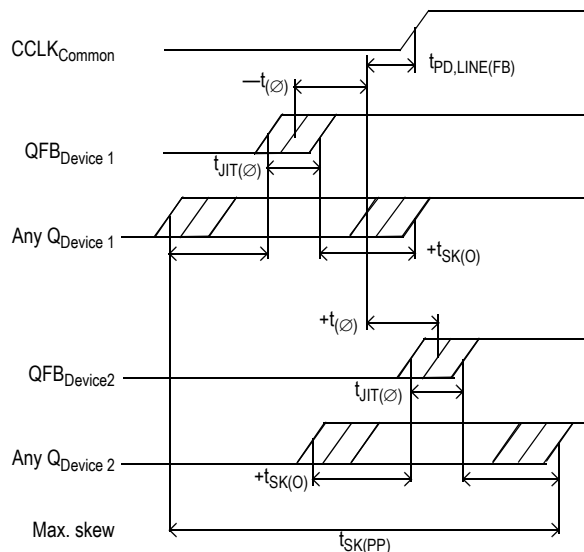

Figure 8. MPC93H51 maximum device-to-device skew

Due to the statistical nature of I/O jitter a RMS value (1σ) is specified. I/O jitter numbers for other confidence factors (CF) can be derived from Table 9.

Table 9. Confidence Factor CF

CF	Probability of clock edge within the distribution
$\pm 1\sigma$	0.68268948
$\pm 2\sigma$	0.95449988
$\pm 3\sigma$	0.99730007
$\pm 4\sigma$	0.99993663
$\pm 5\sigma$	0.99999943
$\pm 6\sigma$	0.99999999

The feedback trace delay is determined by the board layout and can be used to fine-tune the effective delay through each device. In the following example calculation a I/O jitter confidence factor of 99.7% ($\pm 3\sigma$) is assumed, resulting in a worst case timing uncertainty from input to any output of -445 ps to 395 ps relative to CCLK:

$$t_{SK(PP)} = [-200ps...150ps] + [-200ps...200ps] + [(15ps \cdot -3)...(15ps \cdot 3)] + t_{PD, LINE(FB)}$$

$$t_{SK(PP)} = [-445ps...395ps] + t_{PD, LINE(FB)}$$

Driving Transmission Lines

The MPC93H52 clock driver was designed to drive high speed signals in a terminated transmission line environment. To provide the optimum flexibility to the user the output drivers were designed to exhibit the lowest impedance possible. With an output impedance of less than 20 Ω the drivers can drive either parallel or series terminated transmission lines. For more information on transmission lines the reader is referred to Motorola application note AN1091. In most high performance clock networks point-to-point distribution of signals is the method of choice. In a point-to-point scheme either series terminated or parallel terminated transmission lines can be used. The parallel technique terminates the signal at the end of the line with a 50 Ω resistance to $V_{CC}/2$.

This technique draws a fairly high level of DC current and thus only a single terminated line can be driven by each output of the MPC93H52 clock driver. For the series terminated case however there is no DC current draw, thus the outputs can drive multiple series terminated lines. Figure 9. Single versus Dual Transmission Lines illustrates an output driving a single series terminated line versus two series terminated lines in parallel. When taken to its extreme the fanout of the MPC93H52 clock driver is effectively doubled due to its capability to drive multiple lines.

The waveform plots in Figure 10. Single versus Dual Waveforms and Figure 11. Optimized Dual Line Termination show the simulation results of an output driving a

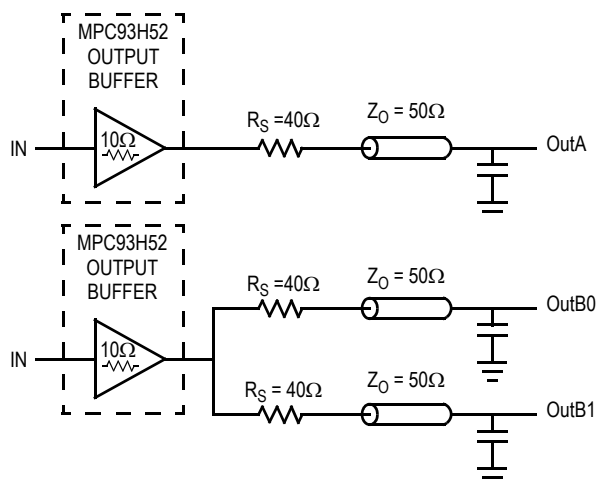

Figure 9. Single versus Dual Transmission Lines

single line versus two lines. In both cases the drive capability of the MPC93H51 output buffer is more than sufficient to drive 50 Ω transmission lines on the incident edge. Note from the delay measurements in the simulations a delta of only 43ps exists between the two differently loaded outputs. This suggests that the dual line driving need not be used exclusively to maintain the tight output-to-output skew of the MPC93H51. The output waveform in Figure 10. Single versus Dual Waveforms and Figure 11. Optimized Dual Line Termination shows a step in the waveform, this step is caused by the impedance mismatch seen looking into the driver. The parallel combination of the 36 Ω series resistor plus the output impedance does not match the parallel combination of the line impedances. The voltage wave launched down the two lines will equal:

$$V_L = V_S (Z_0 \div (R_S + R_0 + Z_0))$$

$$Z_0 = 50\Omega \parallel 50\Omega$$

$$R_S = 40\Omega \parallel 40\Omega$$

$$R_0 = 10\Omega$$

$$V_L = 3.0 (25 \div (20 + 10 + 25)) \\ = 1.36V$$

At the load end the voltage will double, due to the near unity reflection coefficient, to 2.7V. It will then increment towards the quiescent 3.0V in steps separated by one round trip delay (in this case 4.0ns).

Since this step is well above the threshold region it will not cause any false clock triggering, however designers may be uncomfortable with unwanted reflections on the line. To better match the impedances when driving multiple lines the situation in Figure 11. Optimized Dual Line Termination should be used. In this case the series terminating resistors are reduced such that when the parallel combination is added to the output buffer impedance the line impedance is perfectly matched.

MPC93H52

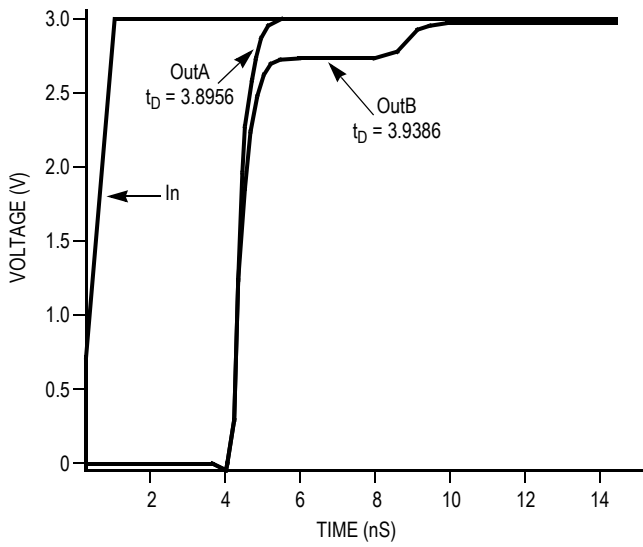

Figure 10. Single versus Dual Waveforms

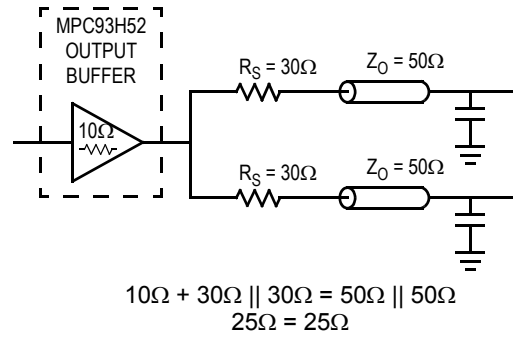

Figure 11. Optimized Dual Line Termination

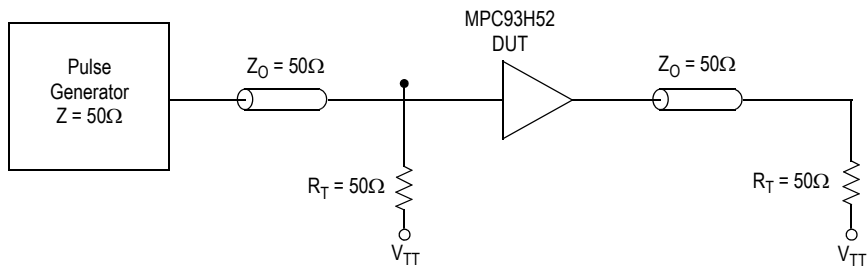
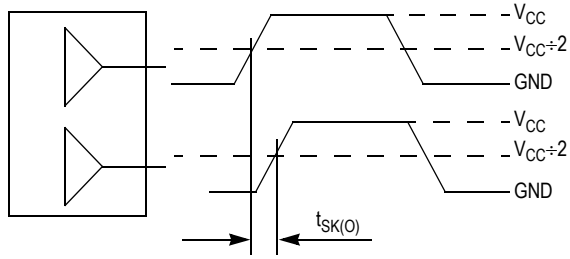

Figure 12. CLK MPC93H52 AC test reference for $V_{CC} = 3.3V$ and $V_{CC} = 2.5V$



The pin-to-pin skew is defined as the worst case difference in propagation delay between any similar delay path within a single device

Figure 13. Output to output Skew $t_{SK(O)}$

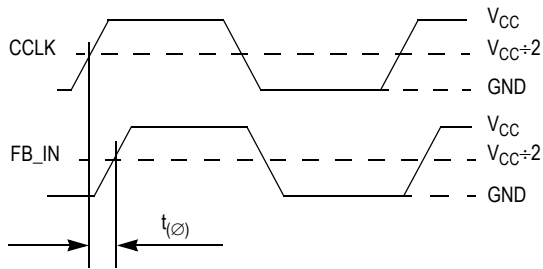
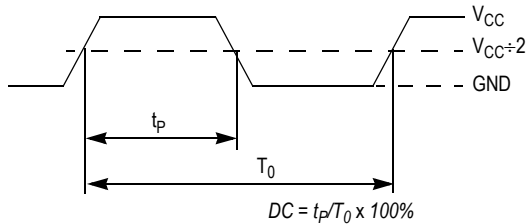
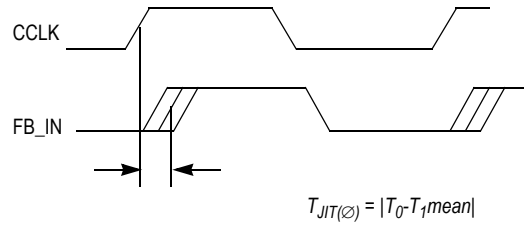

Figure 14. Propagation delay ($t_{(\phi)}$, status phase offset) test reference



The time from the PLL controlled edge to the non controlled edge, divided by the time between PLL controlled edges, expressed as a percentage

Figure 15. Output Duty Cycle (DC)



The deviation in t_0 for a controlled edge with respect to a t_0 mean in a random sample of cycles

Figure 16. I/O Jitter

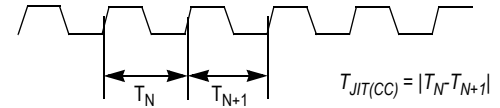

The variation in cycle time of a signal between adjacent cycles, over a random sample of adjacent cycle pairs

Figure 17. Cycle-to-cycle Jitter

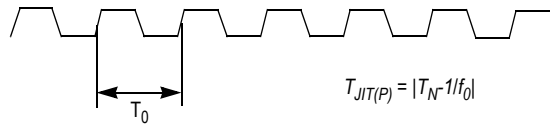

The deviation in cycle time of a signal with respect to the ideal period over a random sample of cycles

Figure 18. Period Jitter

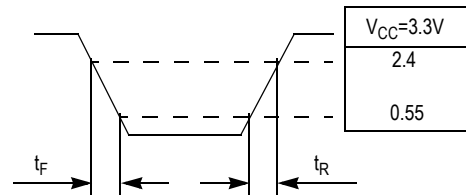
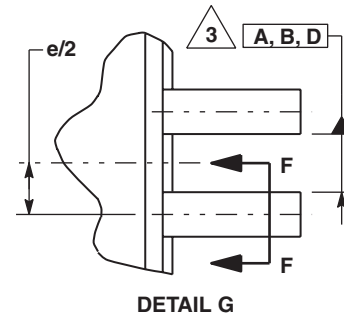
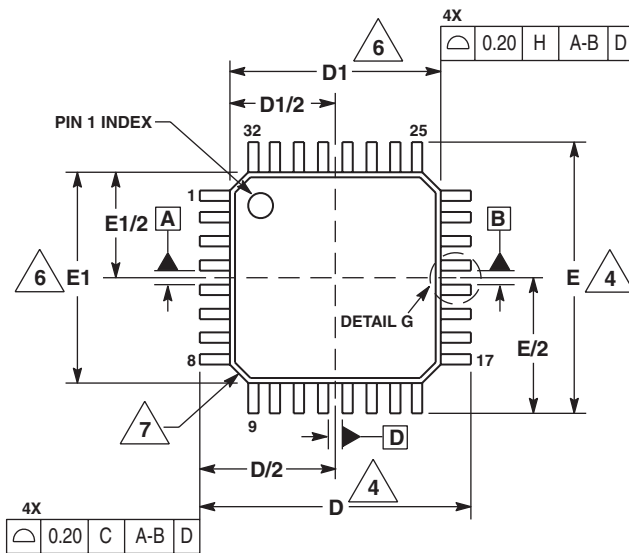

Figure 19. Output Transition Time Test Reference

OUTLINE DIMENSIONS

FA SUFFIX
LQFP PACKAGE
CASE 873A-02
ISSUE B



- NOTES:
1. DIMENSIONS ARE IN MILLIMETERS.
 2. INTERPRET DIMENSIONS AND TOLERANCES PER ASME Y14.5M, 1994.
 3. DATUMS A, B, AND D TO BE DETERMINED AT DATUM PLANE H.
 4. DIMENSIONS D AND E TO BE DETERMINED AT SEATING PLANE C.
 5. DIMENSION b DOES NOT INCLUDE DAMBAR PROTRUSION; ALLOWABLE DAMBAR PROTRUSION SHALL NOT CAUSE THE LEAD WIDTH TO EXCEED THE MAXIMUM b DIMENSION BY MORE THAN 0.08-mm. DAMBAR CANNOT BE LOCATED ON THE LOWER RADIUS OR THE FOOT. MINIMUM SPACE BETWEEN PROTRUSION AND ADJACENT LEAD OR PROTRUSION: 0.07-mm.
 6. DIMENSIONS D1 AND E1 DO NOT INCLUDE MOLD PROTRUSION; ALLOWABLE PROTRUSION IS 0.25-mm PER SIDE. D1 AND E1 ARE MAXIMUM PLASTIC BODY SIZE DIMENSIONS INCLUDING MOLD MISMATCH.
 7. EXACT SHAPE OF EACH CORNER IS OPTIONAL.
 8. THESE DIMENSIONS APPLY TO THE FLAT SECTION OF THE LEAD BETWEEN 0.1-mm AND 0.25-mm FROM THE LEAD TIP.

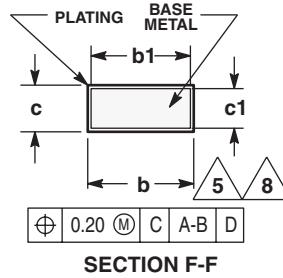
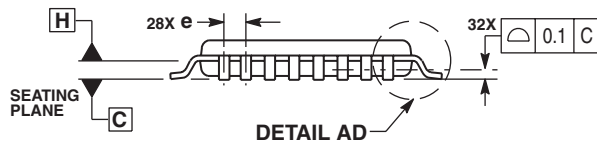

DIM	MILLIMETERS	
	MIN	MAX
A	1.40	1.60
A1	0.05	0.15
A2	1.35	1.45
b	0.30	0.45
b1	0.30	0.40
c	0.09	0.20
c1	0.09	0.16
D	9.00	BSC
D1	7.00	BSC
e	0.80	BSC
E	9.00	BSC
E1	7.00	BSC
L	0.50	0.70
L1	1.00	REF
q	0°	7°
q1	12	REF
R1	0.08	0.20
R2	0.08	---
S	0.20	REF

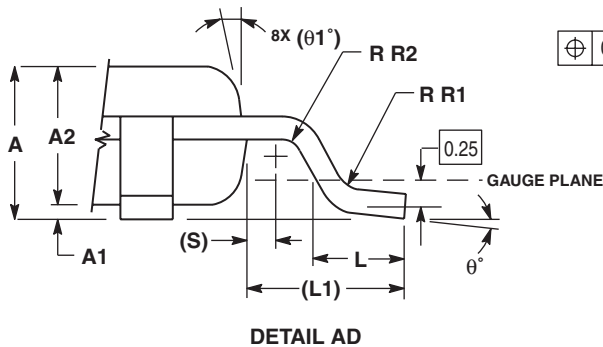

NOTES

NOTES

NOTES

Information in this document is provided solely to enable system and software implementers to use Motorola products. There are no express or implied copyright licenses granted hereunder to design or fabricate any integrated circuits or integrated circuits based on the information in this document.

Motorola reserves the right to make changes without further notice to any products herein. Motorola makes no warranty, representation or guarantee regarding the suitability of its products for any particular purpose, nor does Motorola assume any liability arising out of the application or use of any product or circuit, and specifically disclaims any and all liability, including without limitation consequential or incidental damages. "Typical" parameters which may be provided in Motorola data sheets and/or specifications can and do vary in different applications and actual performance may vary over time. All operating parameters, including "Typicals" must be validated for each customer application by customer's technical experts. Motorola does not convey any license under its patent rights nor the rights of others. Motorola products are not designed, intended, or authorized for use as components in systems intended for surgical implant into the body, or other applications intended to support or sustain life, or for any other application in which the failure of the Motorola product could create a situation where personal injury or death may occur. Should Buyer purchase or use Motorola products for any such unintended or unauthorized application, Buyer shall indemnify and hold Motorola and its officers, employees, subsidiaries, affiliates, and distributors harmless against all claims, costs, damages, and expenses, and reasonable attorney fees arising out of, directly or indirectly, any claim of personal injury or death associated with such unintended or unauthorized use, even if such claim alleges that Motorola was negligent regarding the design or manufacture of the part.

MOTOROLA and the Stylized M Logo are registered in the US Patent and Trademark Office. All other product or service names are the property of their respective owners.

© Motorola, Inc. 2004

HOW TO REACH US:

USA/EUROPE/LOCATIONS NOT LISTED:
Motorola Literature Distribution
P.O. Box 5405, Denver, Colorado 80217
1-800-521-6274 or 480-768-2130

JAPAN: Motorola Japan Ltd.; SPS, Technical Information Center
3-20-1 Minami-Azabu, Minato-ku, Tokyo 106-8573, Japan
81-3-3440-3569

ASIA/PACIFIC: Motorola Semiconductors H.K. Ltd.; Silicon Harbour Centre
2 Dai King Street, Tai Po Industrial Estate, Tai Po, N.T., Hong Kong
852-26668334

HOME PAGE: <http://motorola.com/semiconductors>



MOTOROLA

MPC93H52/D