



Dear customers,

**About the change in the name such as "Oki Electric Industry Co. Ltd." and "OKI" in documents to OKI Semiconductor Co., Ltd.**

The semiconductor business of Oki Electric Industry Co., Ltd. was succeeded to OKI Semiconductor Co., Ltd. on October 1, 2008. Therefore, please accept that although the terms and marks of "Oki Electric Industry Co., Ltd.", "Oki Electric", and "OKI" remain in the documents, they all have been changed to "OKI Semiconductor Co., Ltd.". It is a change of the company name, the company trademark, and the logo, etc. , and NOT a content change in documents.

October 1, 2008  
OKI Semiconductor Co., Ltd.

**OKI SEMICONDUCTOR CO., LTD.**

550-1 Higashiasakawa-cho, Hachioji-shi, Tokyo 193-8550, Japan  
<http://www.okisemi.com/en/>

---

**ML9203-xx****5 × 7 Dot Character × 16-Digit × 2-Line Display Controller/Driver with Character RAM****GENERAL DESCRIPTION**

The ML9203-xx is a 5 × 7 dot matrix type vacuum fluorescent display tube controller driver IC which displays characters, numerics and symbols of a maximum of 16 digits × 2 lines.

Dot matrix vacuum fluorescent display tube drive signals are generated by serial data sent from a micro-controller.

A display system is easily realized by internal ROM and RAM for character display.

The ML9203-xx has low power consumption since it is made by CMOS process technology.

–01 is available as a general-purpose code.

Custom codes are provided on customer's request.

**FEATURES**

- Logic power supply ( $V_{DD}$ ) : 3.3 V $\pm$ 10% or 5.0 V $\pm$ 10%
- VFD tube drive power supply ( $V_{DISP}$ ) : 20 to 60 V
- VFD driver output current  
(VFD driver output can be connected directly to the VFD tube. No pull-down resistor is required.)
  - Segment driver (SEGA1 to A35, SEGB1 to B35)
    - Only one driver output is high : –5 mA ( $V_{DISP} = 60$  V)
    - All the driver outputs are high : –350 mA ( $V_{DISP} = 60$  V)
  - Segment driver (ADA, ADB) : –20 mA ( $V_{DISP} = 60$  V)
  - Grid driver (COM1 to 16) : –50 mA ( $V_{DISP} = 60$  V)
- Content of display
  - SEGA1 to SEGA35 and ADA
    - CGROM\_A 5 × 7 dots : 240 types (character data)
    - CGRAM\_A 5 × 7 dots : 16 types (character data)
    - ADRAM\_A 16 (display digit) × 1 bit (symbol data; can be used for a cursor.)
    - DCRAM\_A 16 (display digit) × 8 bits (register for character data display)
  - SEGB1 to SEGB35 and ADB
    - CGROM\_B 5 × 7 dots : 240 types (character data)
    - CGRAM\_B 5 × 7 dots : 16 types (character data)
    - ADRAM\_B 16 (display digit) × 1 bit (symbol data; can be used for a cursor.)
    - DCRAM\_B 16 (display digit) × 8 bits (register for character data display)
- Display control function
  - Display digit : 1 to 16 digits
  - Display duty (brightness adjustment): 0/1024 to 960/1024 stages
  - All lights ON/OFF
- 4 interfaces with microcontroller : DA,  $\overline{CS}$ ,  $\overline{CP}$ , and  $\overline{RESET}$
- Built-in oscillation circuit  
Crystal oscillation or ceramic oscillation: 4.0 MHz (Typ)
- Standby function  
Inhibiting the oscillator circuit provides low power consumption.
- Package options:  
100-pin plastic QFP (QFP100-P-1420-0.65-BK) (Product name: ML9203-xxGA)

**BLOCK DIAGRAM**

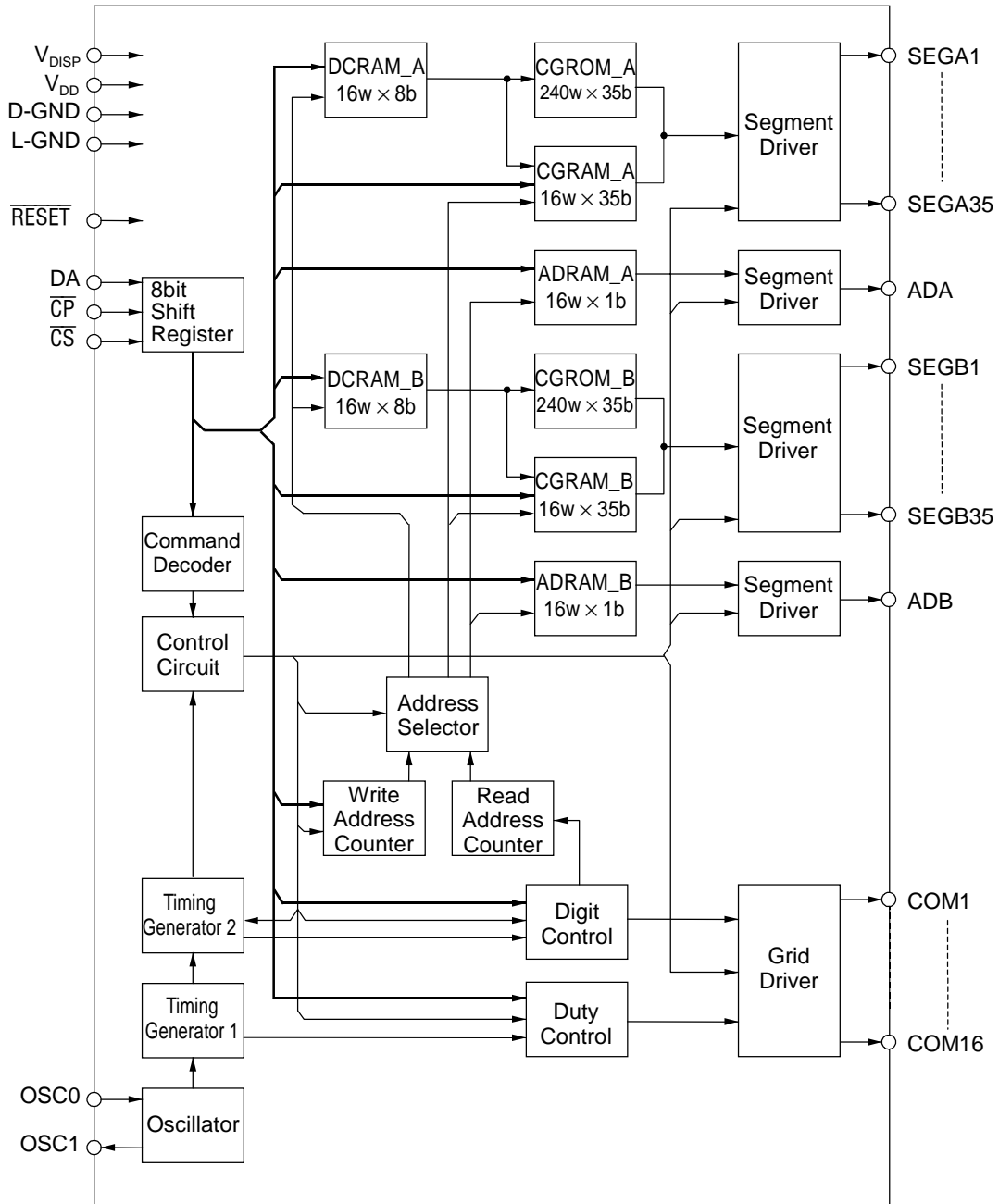

**PIN CONFIGURATION (TOP VIEW)**

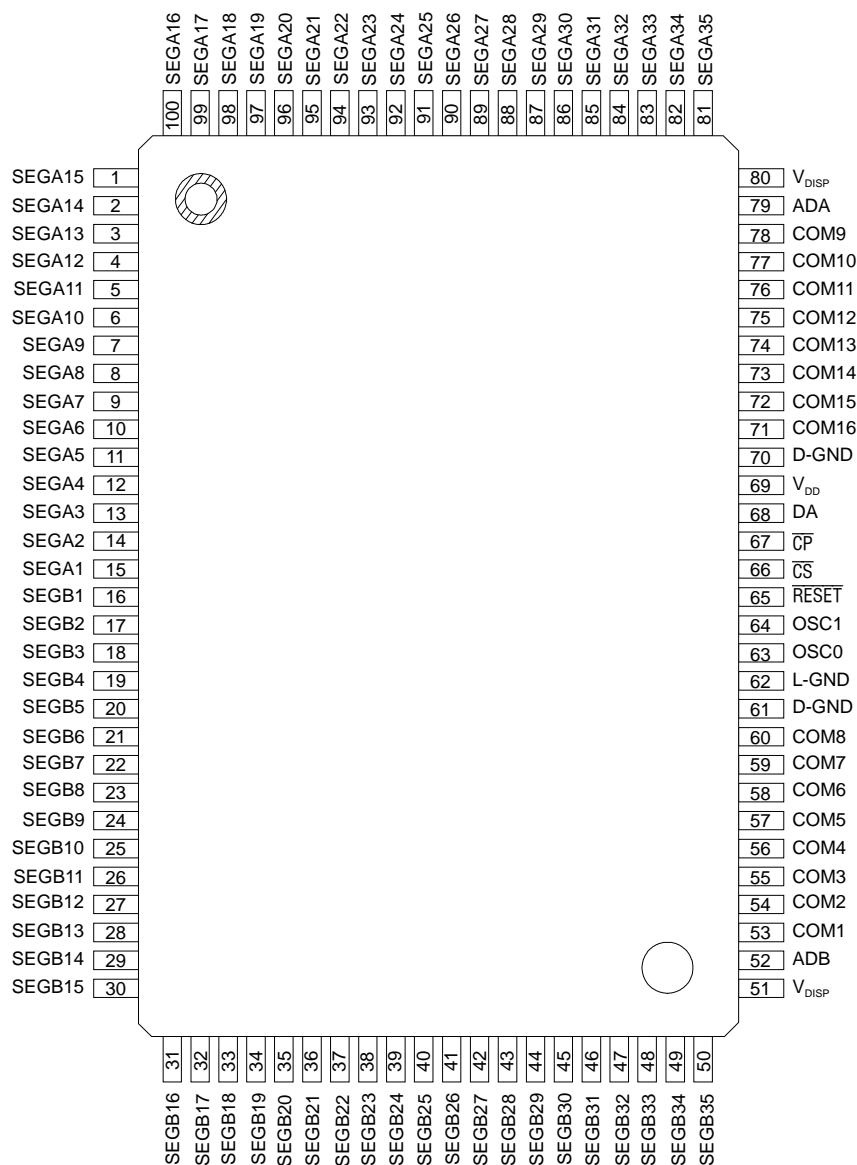

**100-Pin Plastic QFP**

## PIN DESCRIPTION

Pin	Symbol	Type	Connects to	Description
1 to 15, 81 to 100	SEGA1 to A35	O	VFD tube anode electrode	VFD tube anode electrode drive output. Directly connected to fluorescent display tube and a pull-down resistor is not necessary. $I_{OH} > -5$ mA
16 to 50	SEGB1 to B35			
53 to 60, 71 to 78	COM1 to 16	O	VFD tube grid electrode	VFD tube grid electrode drive output. Directly connected to fluorescent display tube and a pull-down resistor is not necessary. $I_{OH} > -50$ mA
52, 79	ADA, ADB	O	VFD tube anode electrode	VFD tube anode electrode drive output. Directly connected to fluorescent display tube and a pull-down resistor is not necessary. $I_{OH} > -20$ mA
69	$V_{DD}$	—	Power supply	$V_{DD}$ -L-GND are power supplies for internal logic. $V_{DISP}$ -D-GND are power supplies for driving fluorescent tubes. Apply $V_{DISP}$ after $V_{DD}$ is applied. Use the same power supply for L-GND and D-GND.
62	L-GND			
51, 80	$V_{DISP}$			
61, 70	D-GND			
68	DA	I	Micro- controller	Serial data input (positive logic). Input from LSB.
67	$\overline{CP}$	I	Micro- controller	Shift clock input. Serial data is shifted on the rising edge of $\overline{CP}$ .
66	$\overline{CS}$	I	Micro- controller	Chip select input. Serial data transfer is disabled when $\overline{CS}$ pin is "H" level.
65	$\overline{RESET}$	I	Micro- controller	Reset input. "Low" initializes all the functions. Initial status is as follows. <ul style="list-style-type: none"> <li>• Address of each RAM ..... address "00" H</li> <li>• Data of each RAM ..... Content is undefined</li> <li>• Display digit ..... 16 digits</li> <li>• Brightness adjustment ..... 0/1024</li> <li>• All lights ON or OFF ..... OFF mode</li> </ul>
63	OSC0	I	Crystal or ceramic resonator	Pins for self-oscillation. (Do not apply external clocks to these pins.) Connect these pins to the crystal and capacitors or to the ceramic resonator and capacitors. The target oscillation frequency is 4.0 MHz. (Note that the device includes the feed back resistor of 1 M $\Omega$ .) See Application Circuit.
64	OSC1	O		

**ABSOLUTE MAXIMUM RATINGS**

Parameter	Symbol	Condition	Rating	Unit
Supply Voltage (1)	$V_{DD}$	—	-0.3 to +6.5	V
Supply Voltage (2)	$V_{DISP}$	—	-0.3 to +70	V
Input Voltage	$V_{IN}$	—	-0.3 to $V_{DD}+0.3$	V
Power Dissipation	$P_D$	$T_a \geq 25^\circ\text{C}$	470	mW
Storage Temperature	$T_{STG}$	—	-55 to +150	$^\circ\text{C}$
Output Current	$I_{O1}$	COM1 to COM16	-60 to 0.0	mA
	$I_{O2}$	ADA, ADB	-30 to 0.0	mA
	$I_{O3}$	SEGA1 to SEGA35, SEGB1 to SEGB35	-10 to 0.0	mA

**RECOMMENDED OPERATING CONDITIONS**

Parameter	Symbol	Condition	Min.	Typ.	Max.	Unit
Supply Voltage (1)	$V_{DD}$	When the power supply voltage is 5 V (typ.)	4.5	5.0	5.5	V
		When the power supply voltage is 3.3 V (typ.)	3.0	3.3	3.6	V
Supply Voltage (2)	$V_{DISP}$	—	20	—	60	V
Operating Frequency	$f_{OSC}$	Oscillation	3.5	4.0	4.5	MHz
Frame Frequency	$f_{FR}$	DIGIT = 1 to 16, oscillation	213	244	275	Hz
Operating Temperature	$T_{OP}$	—	-40	—	+85	$^\circ\text{C}$

## ELECTRICAL CHARACTERISTICS

### DC Characteristics

( $V_{DD} = 5.0\text{ V} \pm 10\%$ , or  $V_{DD} = 3.3\text{ V} \pm 10\%$ ,  $V_{DISP} = 20\text{ to }60\text{ V}$ ,  $T_a = -40\text{ to }+85^\circ\text{C}$ , unless otherwise specified)

Parameter	Symbol	Applied pin	Condition	Min.	Max.	Unit	
High Level Input Voltage	$V_{IH}$	*1	$V_{DD} = 5.0\text{ V} \pm 10\%$	$0.7 V_{DD}$	—	V	
			$V_{DD} = 3.3\text{ V} \pm 10\%$	$0.8 V_{DD}$	—	V	
Low Level Input Voltage	$V_{IL}$	*1	$V_{DD} = 5.0\text{ V} \pm 10\%$	—	$0.3 V_{DD}$	V	
			$V_{DD} = 3.3\text{ V} \pm 10\%$	—	$0.2 V_{DD}$	V	
High Level Input Current	$I_{IH}$	*1	$V_{IH} = V_{DD}$	-1.0	+1.0	$\mu\text{A}$	
Low Level Input Current	$I_{IL}$	*1	$V_{IL} = 0.0\text{ V}$	-1.0	+1.0	$\mu\text{A}$	
High Level Output Voltage	$V_{OH1}$	COM1 to 16	$V_{DISP} = 60\text{ V}$ , $I_{OH1} = -50\text{ mA}$	$V_{DISP} - 2.0$	—	V	
	$V_{OH2}$	ADA, ADB	$V_{DISP} = 60\text{ V}$ , $I_{OH2} = -20\text{ mA}$	$V_{DISP} - 2.0$	—	V	
	$V_{OH3}$	SEGA1 to A35 SEGB1 to B35	$V_{DISP} = 60\text{ V}$ , $I_{OH3} = -5\text{ mA}$	$V_{DISP} - 2.0$	—	V	
Low Level Output Voltage	$V_{OL1}$	*2	—	—	1.0	V	
Supply Current (1)	$I_{DD1}$	$V_{DD}$	$V_{DD} = 5.0\text{ V} \pm 10\%$ , $f_{OSC} = 4.0\text{ MHz}$	—	6.0	mA	
	$I_{DD2}$			$V_{DD} = 3.3\text{ V} \pm 10\%$ , $f_{OSC} = 4.0\text{ MHz}$	—	4.0	mA
	$I_{DISP1}$	$V_{DISP}$	$f_{OSC} = 4.0\text{ MHz}$ , no load	All output lights ON	—	1.0	mA
	$I_{DISP2}$			All output lights OFF	—	200	$\mu\text{A}$
Supply Current (2)	$I_{DD}$	$V_{DD}$	In standby mode	—	1.0	$\mu\text{A}$	
	$I_{DISP}$	$V_{DISP}$		—	20.0	$\mu\text{A}$	

\*1)  $\overline{CS}$ ,  $\overline{CP}$ , DA,  $\overline{RESET}$

\*2) SEGA1 to A35, SEGB1 to B35, ADA, ADB, COM1 to 16

## AC Characteristics

(V<sub>DD</sub> = 5.0 V±10%, or V<sub>DD</sub> = 3.3 V±10%, V<sub>DISP</sub> = 20 to 60 V, Ta = -40 to +85°C unless otherwise specified)

Parameter	Symbol	Condition	Min.	Max.	Unit	
$\overline{CP}$ Frequency	f <sub>C</sub>	—	—	2.0	MHz	
$\overline{CP}$ Pulse Width	t <sub>CW</sub>	—	200	—	ns	
DA Setup Time	t <sub>DS</sub>	—	200	—	ns	
DA Hold Time	t <sub>DH</sub>	—	200	—	ns	
$\overline{CS}$ Setup Time	t <sub>CSS</sub>	—	200	—	ns	
$\overline{CS}$ Hold Time	t <sub>CSH</sub>	Oscillating state	8	—	μs	
$\overline{CS}$ Wait Time	t <sub>CSW</sub>	—	200	—	ns	
Data Processing Time	t <sub>DOFF</sub>	Oscillating state	4	—	μs	
$\overline{RESET}$ Pulse Width	t <sub>WRES</sub>	When $\overline{RESET}$ signal is input from microcontroller etc. externally	200	—	ns	
$\overline{RESET}$ Time	t <sub>RSON</sub>	—	t <sub>OSCON</sub>	—		
DA Wait Time	t <sub>RSOFF</sub>	—	200	—	ns	
All Output Slew Rate	t <sub>R</sub>	C <sub>1</sub> = 100 pF	t <sub>R</sub> = 20 to 80%	—	2.0	μs
	t <sub>F</sub>		t <sub>F</sub> = 80 to 20%	—	2.0	μs
OSC Duty Ratio	du <sub>OSC</sub>	—	40	60	%	
Oscillation Start-up Time	t <sub>OSCON</sub>	—	*1			

\*1 t<sub>OSCON</sub> depends on the type of crystal or resonator. Refer to characteristic data of crystal or resonator used.

**TIMING DIAGRAM**

Symbol	$V_{DD} = 3.3\text{ V} \pm 10\%$	$V_{DD} = 5.0\text{ V} \pm 10\%$
$V_{IH}$	$0.8 V_{DD}$	$0.7 V_{DD}$
$V_{IL}$	$0.2 V_{DD}$	$0.3 V_{DD}$

**• Data Timing**

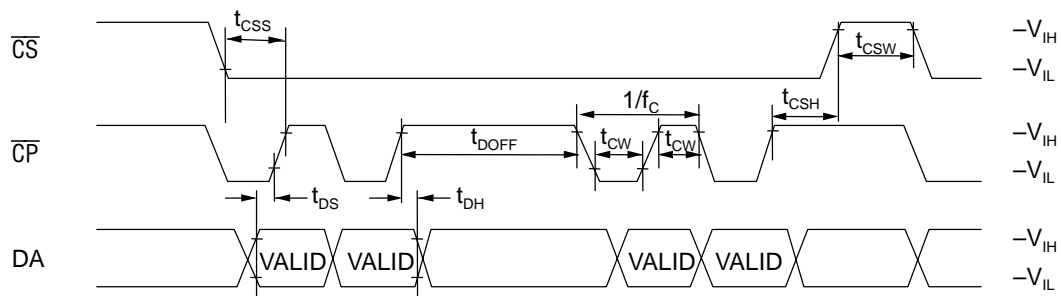

**• Reset Timing**

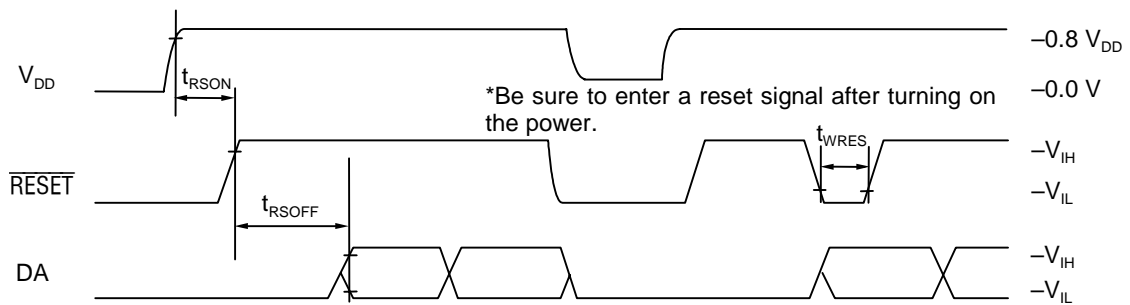

**• Output Timing**

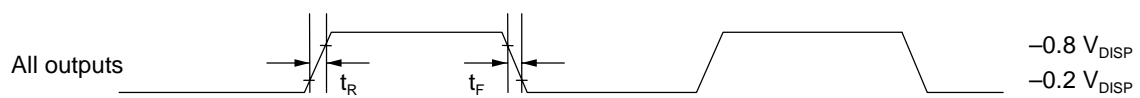

• Digit Output Timing (for 16-digit display, at a duty of 960/1024)

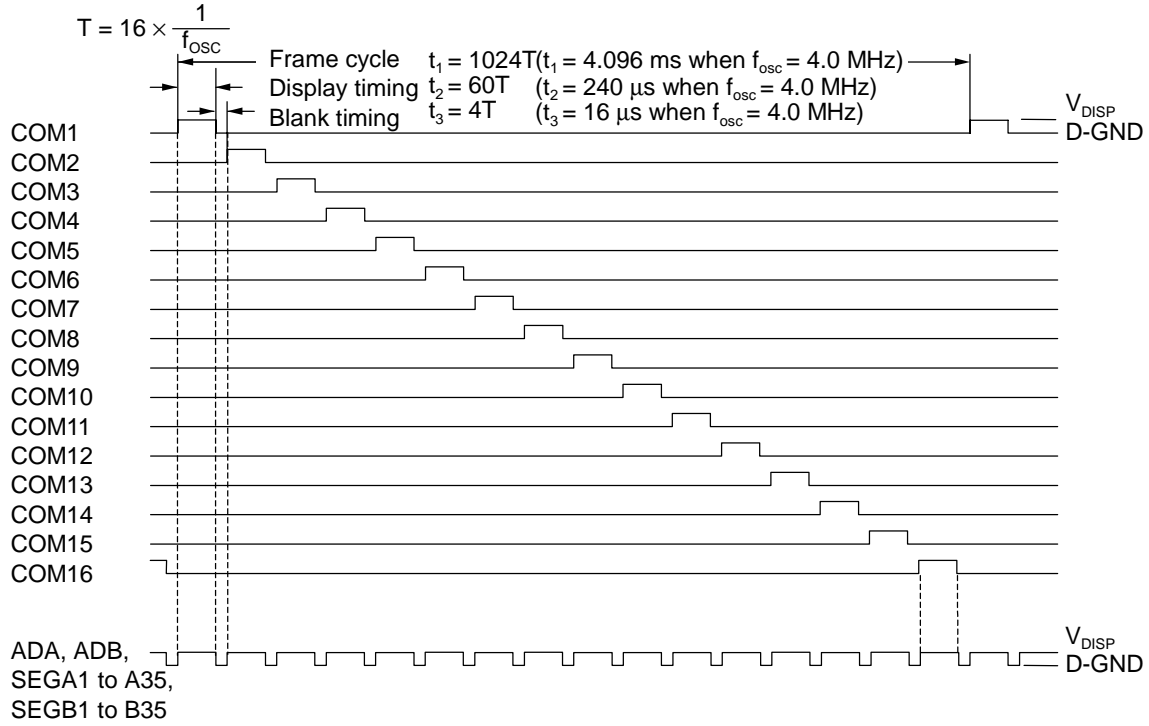

• Standby Release Timing

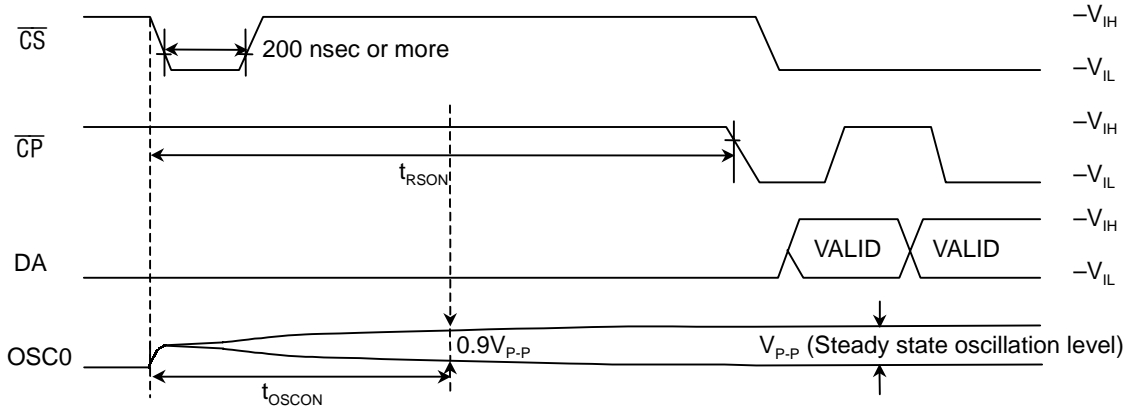

• OSC Timing

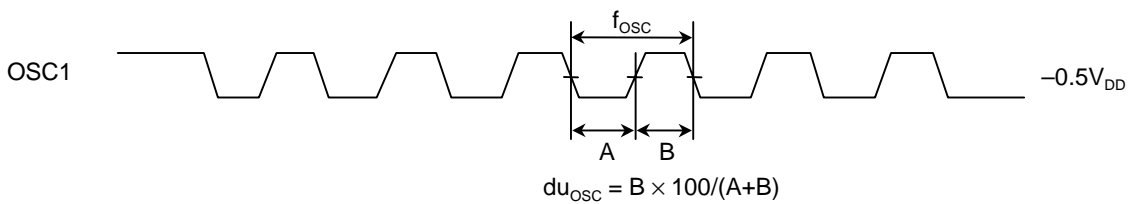

## FUNCTIONAL DESCRIPTION

### Commands List

	Command	1st byte				MSB				2nd byte				MSB					
		B0	B1	B2	B3	B4	B5	B6	B7	B0	B1	B2	B3	B4	B5	B6	B7		
1	DCRAM_A data write	X0	X1	X2	X3	1	0	0	0	C0	C1	C2	C3	C4	C5	C6	C7		
2	CGRAM_A data write	X0	X1	X2	X3	0	1	0	0	C0	C5	C10	C15	C20	C25	C30	*	2nd byte	
										C1	C6	C11	C16	C21	C26	C31	*	3rd byte	
										C2	C7	C12	C17	C22	C27	C32	*	4th byte	
										C3	C8	C13	C18	C23	C28	C33	*	5th byte	
									C4	C9	C14	C19	C24	C29	C34	*	6th byte		
3	ADRAM_A data write	X0	X1	X2	X3	1	1	0	0	C0	*	*	*	*	*	*	*		
5	Display duty set	D0	D1	*	*	1	0	1	0	D2	D3	D4	D5	D6	D7	D8	D9		
6	Number of digits set	K0	K1	K2	K3	0	1	1	0										
7	All lights ON/OFF	L	H	*	*	1	1	1	0										
9	DCRAM_B data write	X0	X1	X2	X3	1	0	0	1	C0	C1	C2	C3	C4	C5	C6	C7		
A	CGRAM_B data write	X0	X1	X2	X3	0	1	0	1	C0	C5	C10	C15	C20	C25	C30	*	2nd byte	
										C1	C6	C11	C16	C21	C26	C31	*	3rd byte	
										C2	C7	C12	C17	C22	C27	C32	*	4th byte	
										C3	C8	C13	C18	C23	C28	C33	*	5th byte	
									C4	C9	C14	C19	C24	C29	C34	*	6th byte		
B	ADRAM_B data write	X0	X1	X2	X3	1	1	0	1	C0	*	*	*	*	*	*	*		
F	Standby mode	*	*	*	*	1	1	1	1										
	(Test mode) Note)																		

\* : Don't care

Xn : Address specification for each RAM

Cn : Character code specification for each RAM

Dn : Display duty specification

Kn : Number of digits specification

H : All lights ON instruction

L : All lights OFF instruction

When data is written to RAM (DCRAM, CGRAM, ADRAM) continuously, addresses are internally incremented automatically.

Therefore it is not necessary to specify the 1st byte to write RAM data for the 2nd and later bytes.

Note: The test mode is used for inspection before shipment. It is not a user function. The user cannot use this command. Enter commands 1 to 3, 5 to 7, 9 to B, and F alone in the way described on the next page and the following pages. (The operation of this device cannot be guaranteed if other commands are used.)

**Positional Relationship Between SEGn and ADn (one digit)**

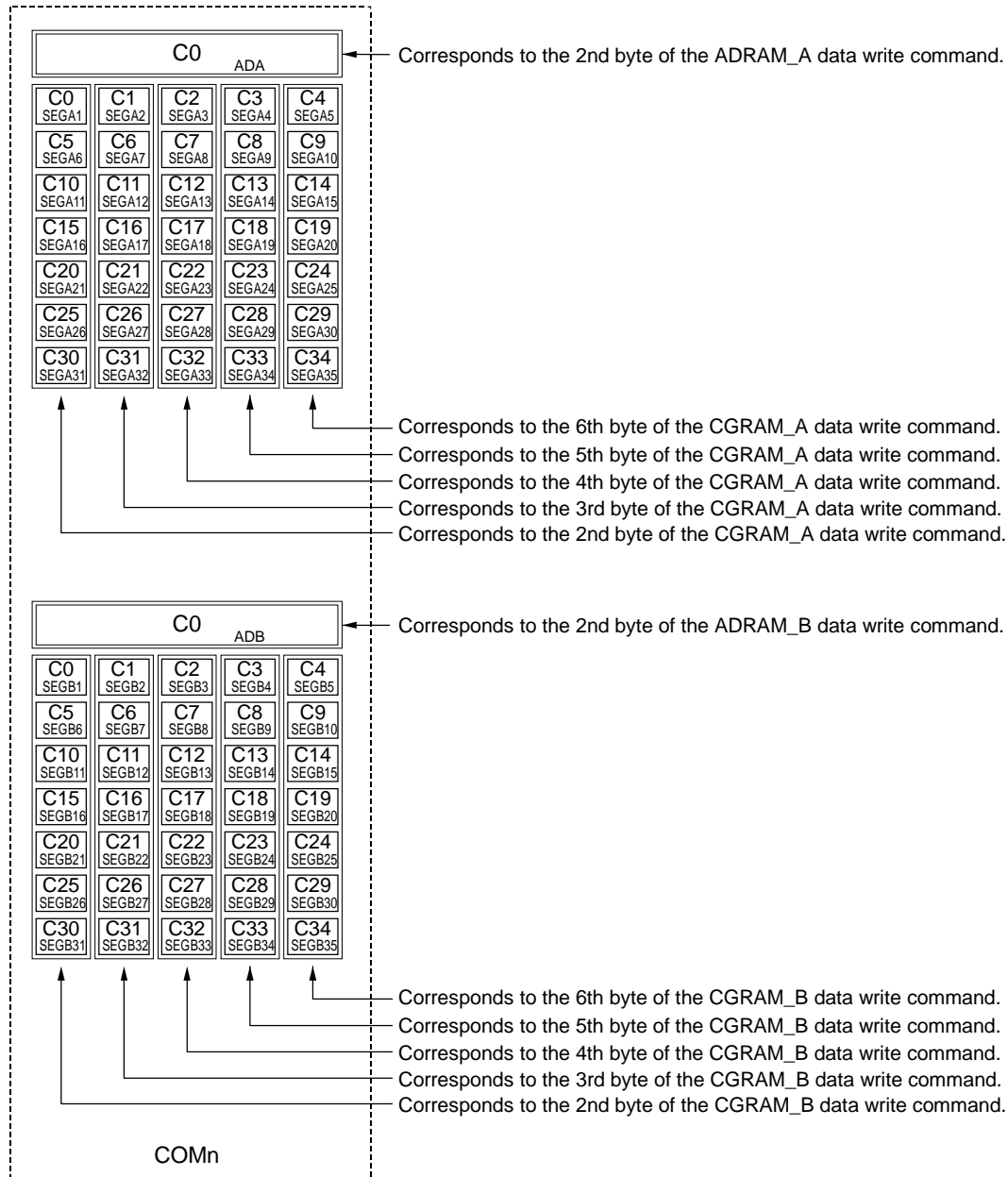

### Data Transfer Method and Command Write Method

Display control command and data are written by an 8-bit serial transfer. Write timing is shown in the figure below.

Setting the  $\overline{CS}$  pin to “Low” level enables a data transfer.

Data is 8 bits and is sequentially input into the DA pin from LSB (LSB first).

As shown in the figure below, data is read by the shift register at the rising edge of the shift clock, which is input into the  $\overline{CP}$  pin. If 8-bit data is input, internal load signals are automatically generated and data is written to each register and RAM.

Therefore it is not necessary to input load signals from the outside.

Setting the  $\overline{CS}$  pin to “High” disables data transfer. Data input from the point when the  $\overline{CS}$  pin changes from “High” to “Low” is recognized in 8-bit units.

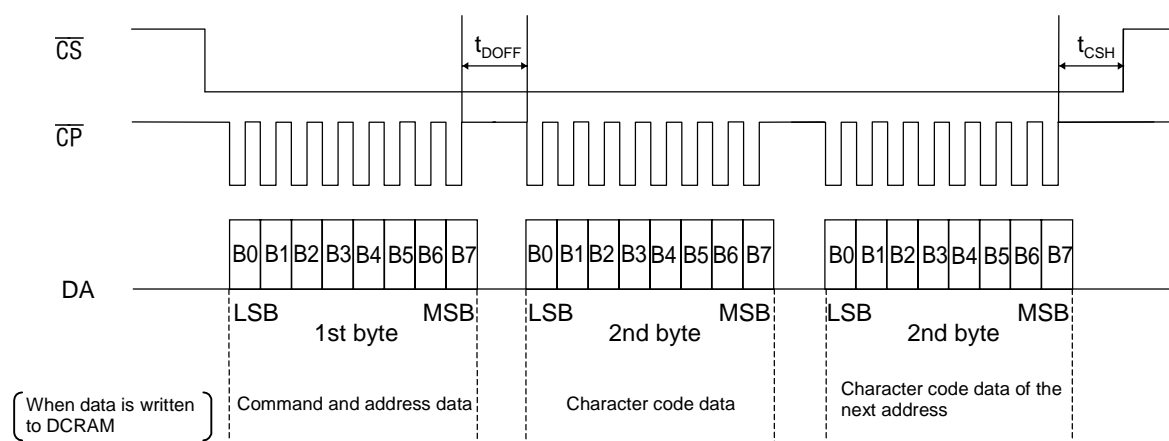

Note: When data is written to RAM (DCRAM, ADRAM, CGRAM) continuously, addresses are internally incremented automatically.

Therefore it is not necessary to specify the 1st byte to write RAM data for the 2nd and later bytes.

### Address Transition

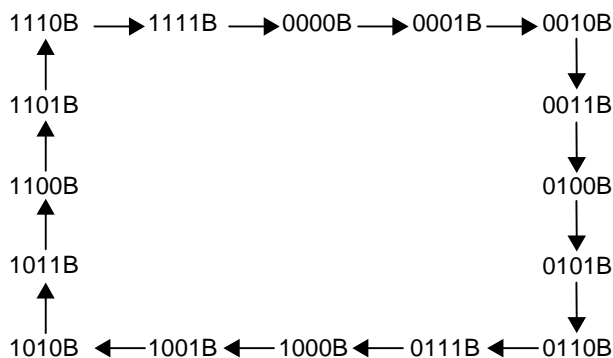

Addresses are in transit from 0000B to 1111B in a loop while being incremented by one for each transition.(1111B is followed by 0000B.)

### Reset Function

Reset is executed when the  $\overline{\text{RESET}}$  pin is set to “L”, (when turning power on, for example) and initializes all functions.

Initial status is as follows.

- Address of each RAM .....address “00”H
- Data of each RAM.....All contents are undefined
- Display digit .....16 digits
- Brightness adjustment .....0/1024
- All display lights ON or OFF .....OFF mode
- Segment output.....All segment outputs go “Low”
- AD output.....All AD outputs go “Low”

Be sure to execute the reset operation when turning power on and set again according to “Setting Flowchart” after reset.

## Description of Commands and Functions

### 1, 9. DCRAM data write

(Specifies the address 00H to 0FH of DCRAM and writes the character code of CGROM and CGRAM.)

DCRAM (Data Control RAM) has a 4-bit address to store character code of CGROM and CGRAM.

The character code specified by DCRAM is converted to a  $5 \times 7$  dot matrix character pattern via CGROM or CGRAM.

(The DCRAM can store 16 characters.)

[Command format]

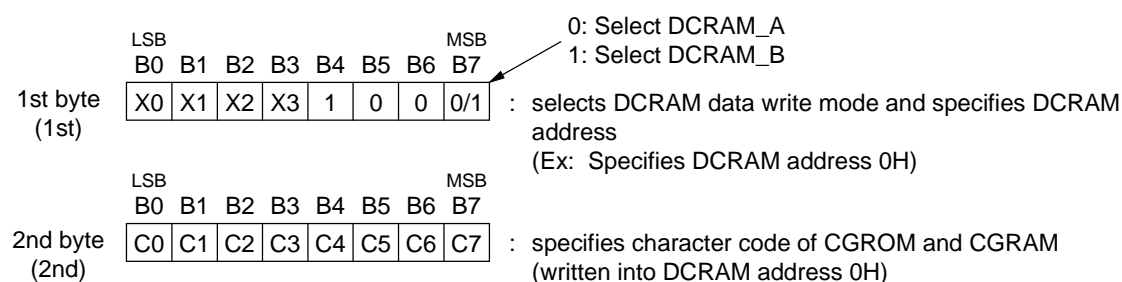

Note: To specify the character code of CGROM and CGRAM continuously to the next address, specify only character code as follows.

The addresses of DCRAM are automatically incremented. Specification of an address is unnecessary.

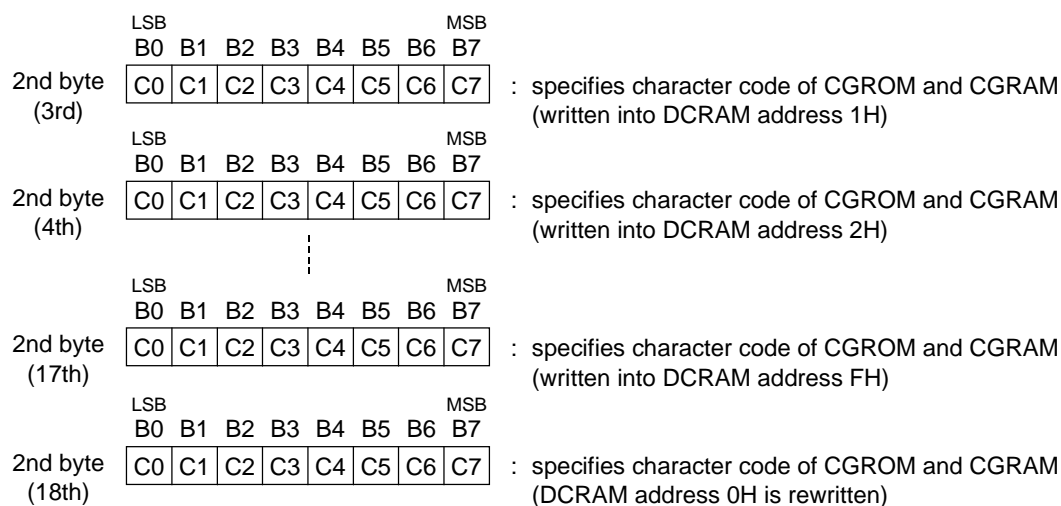

X0 (LSB) to X3 (MSB): DCRAM addresses (4 bits: 16 characters)

C0 (LSB) to C7 (MSB): Character code of CGROM and CGRAM (8 bits: 256 characters)

[COM positions and set DCRAM addresses]

Hex	X0	X1	X2	X3	COM position
0	0	0	0	0	COM1
1	1	0	0	0	COM2
2	0	1	0	0	COM3
3	1	1	0	0	COM4
4	0	0	1	0	COM5
5	1	0	1	0	COM6
6	0	1	1	0	COM7
7	1	1	1	0	COM8
8	0	0	0	1	COM9
9	1	0	0	1	COM10
A	0	1	0	1	COM11
B	1	1	0	1	COM12
C	0	0	1	1	COM13
D	1	0	1	1	COM14
E	0	1	1	1	COM15
F	1	1	1	1	COM16





X0 (LSB) to X3 (MSB) : CGRAM addresses (4 bits: 16 characters)  
 C0 (LSB) to C34 (MSB) : Character pattern data (35 bits: 35 outputs per digit)  
 \* : Don't care

[CGROM addresses and set CGRAM addresses]

Refer to ROM code tables.

HEX	X0	X1	X2	X3	CGROM address	HEX	X0	X1	X2	X3	CGROM address
0	0	0	0	0	RAM00 (00000000B)	8	0	0	0	1	RAM08 (00001000B)
1	1	0	0	0	RAM01 (00000001B)	9	1	0	0	1	RAM09 (00001001B)
2	0	1	0	0	RAM02 (00000010B)	A	0	1	0	1	RAM0A (00001010B)
3	1	1	0	0	RAM03 (00000011B)	B	1	1	0	1	RAM0B (00001011B)
4	0	0	1	0	RAM04 (00000100B)	C	0	0	1	1	RAM0C (00001100B)
5	1	0	1	0	RAM05 (00000101B)	D	1	0	1	1	RAM0D (00001101B)
6	0	1	1	0	RAM06 (00000110B)	E	0	1	1	1	RAM0E (00001110B)
7	1	1	1	0	RAM07 (00000111B)	F	1	1	1	1	RAM0F (00001111B)

Positional relationship between the output area of CGROM and that of CGRAM

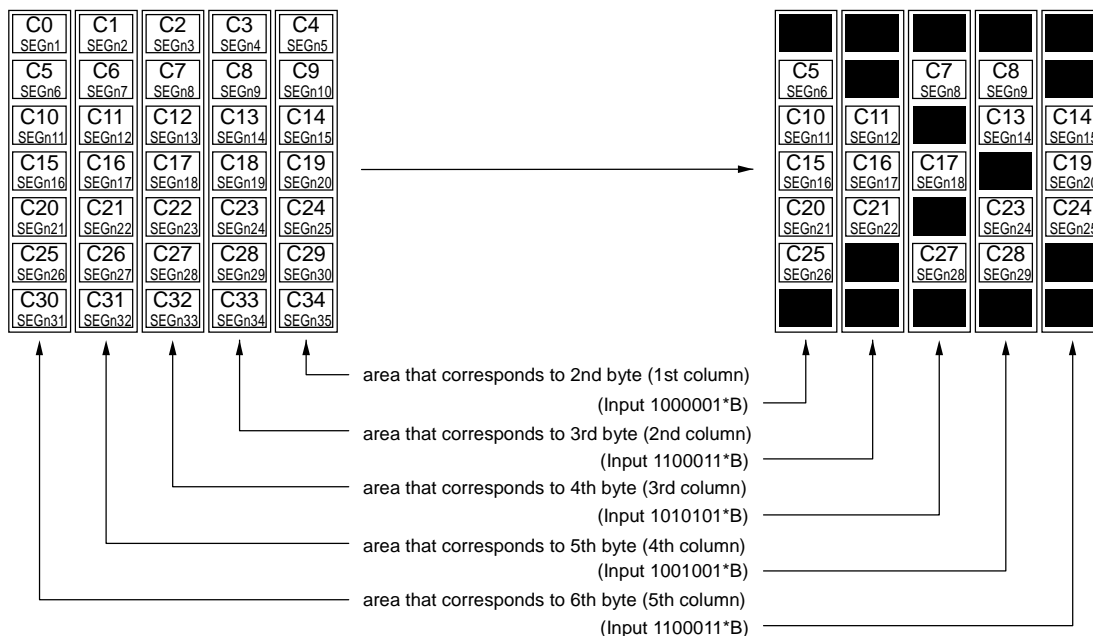

Note: CGROM\_A and CGROM\_B (Character Generator ROM A, B) have an 8-bit address to generate 5 × 7 dot matrix character patterns.  
 Each of CGROM\_A and CGROM\_B can store 240 types of character patterns.  
 The contents of CGROM\_A and CGROM\_B can be set separately.  
 General-purpose code -01 is available (see ROM code tables) and custom codes are provided on customer's request.

3. B. ADRAM data write

(specifies address 00H to 0FH of ADRAM and writes symbol data)

ADRAM (Additional Data RAM) has a 1-bit address to store symbol data.  
 Symbol data specified by ADRAM is directly output without CGROM and CGRAM.  
 (The ADRAM can store 1 type of symbol patterns for each digit.)  
 The terminal to which the contents of ADRAM are output can be used as a cursor.

[Command format]

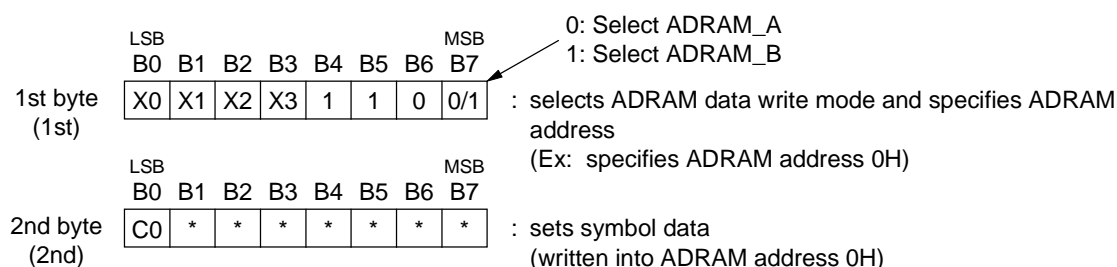

Note: To specify symbol data continuously to the next address, specify only character data as follows.  
 The address of ADRAM is automatically incremented. Specification of addresses is unnecessary.

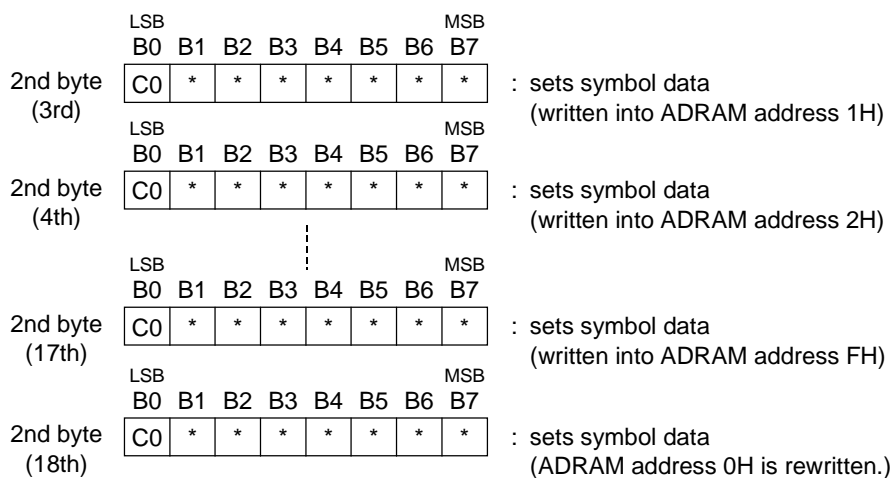

X0 (LSB) to X3 (MSB) : ADRAM addresses (4 bits: 16 characters)  
 C0 : Symbol data (1 bit: 1-symbol data per digit)  
 \* : Don't care

[COM positions and ADRAM addresses]

Hex	X0	X1	X2	X3	COM position
0	0	0	0	0	COM1
1	1	0	0	0	COM2
2	0	1	0	0	COM3
3	1	1	0	0	COM4
4	0	0	1	0	COM5
5	1	0	1	0	COM6
6	0	1	1	0	COM7
7	1	1	1	0	COM8
8	0	0	0	1	COM9
9	1	0	0	1	COM10
A	0	1	0	1	COM11
B	1	1	0	1	COM12
C	0	0	1	1	COM13
D	1	0	1	1	COM14
E	0	1	1	1	COM15
F	1	1	1	1	COM16

5. Display duty set  
(writes display duty value to duty cycle register)

Display duty adjusts brightness in 960 stages of 0/1024 to 960/1024 using 10-bit data.

When the  $\overline{\text{RESET}}$  signal is input, the duty cycle register value is "0". (see "Reset Function") Always execute this instruction before turning the display on, then set a desired duty value.

[Command format]

1st byte

LSB	B0	B1	B2	B3	B4	B5	B6	B7	MSB
D0	D1	*	*	1	0	1	0		

: selects display duty set mode and sets duty value (lower 2 bits)

2nd byte  
(2nd)

LSB	B0	B1	B2	B3	B4	B5	B6	B7	MSB
D2	D3	D4	D5	D6	D7	D8	D9		

: sets duty value (upper 8 bits)

D0 (LSB) to D9 (MSB) : Display duty data (10 bits: 0/1024 to 960/1024 stages)

\* : Don't care

[Relation between setup data and controlled COM duty]

HEX	D0	D1	D2	D3	D4	D5	D6	D7	D8	D9	COM duty
000	0	0	0	0	0	0	0	0	0	0	0/1024
001	1	0	0	0	0	0	0	0	0	0	1/1024
002	0	1	0	0	0	0	0	0	0	0	2/1024
⋮											⋮
3BE	0	1	1	1	1	1	0	1	1	1	958/1024
3BF	1	1	1	1	1	1	0	1	1	1	959/1024
3C0	0	0	0	0	0	0	1	1	1	1	960/1024
3C1	1	0	0	0	0	0	1	1	1	1	960/1024
⋮											⋮
3FE	0	1	1	1	1	1	1	1	1	1	960/1024
3FF	1	1	1	1	1	1	1	1	1	1	960/1024

→ The state when  $\overline{\text{RESET}}$  signal is input.

6. Number of digits set  
(writes the number of display digits to the display digit register)

The number of digits set can display 1 to 16 digits using 4-bit data.

When the  $\overline{\text{RESET}}$  signal is input, the number of digit register value is "0". (see "Reset Function") Always execute this instruction to change the number of digits before turning the display on.

[Command format]

	LSB							MSB	
	B0	B1	B2	B3	B4	B5	B6	B7	
1st byte	K0	K1	K2	K3	0	1	1	0	: selects the number of digit set mode and specifies the number of digit value

K0 (LSB) to K3 (MSB) : Number of digit data (4 bits: 16 digits)

\* : Don't care

[Relation between setup data and controlled COM]

HEX	K0	K1	K2	K3	Number of digits of COM	HEX	K0	K1	K2	K3	Number of digits of COM
0	0	0	0	0	COM1 to 16	0	0	0	0	1	COM1 to 8
1	1	0	0	0	COM1	1	1	0	0	1	COM1 to 9
2	0	1	0	0	COM1 to 2	2	0	1	0	1	COM1 to 10
3	1	1	0	0	COM1 to 3	3	1	1	0	1	COM1 to 11
4	0	0	1	0	COM1 to 4	4	0	0	1	1	COM1 to 12
5	1	0	1	0	COM1 to 5	5	1	0	1	1	COM1 to 13
6	0	1	1	0	COM1 to 6	6	0	1	1	1	COM1 to 14
7	1	1	1	0	COM1 to 7	7	1	1	1	1	COM1 to 15

— The state when  $\overline{\text{RESET}}$  signal is input.

7. All display lights ON/OFF set  
(Turns all display lights ON or OFF)

When the  $\overline{\text{RESET}}$  signal is input, all segment, common and AD outputs go “Low”. (see “Reset Function”)

All display lights ON is used primarily for display testing.

All display lights OFF is primarily used for display blink and to prevent malfunction when power is turned on.

[Command format]

	LSB							MSB	
	B0	B1	B2	B3	B4	B5	B6	B7	
1st byte	L	H	*	*	1	1	1	0	: selects all display lights ON or OFF mode

L: All-display lights OFF command

H: All-display lights ON command

\*: Don't care

[Set data and display state of SEG and AD]

L	H	Display state of SEG and AD	
0	0	Normal display	
1	0	Sets all outputs to Low	(The state when $\overline{\text{RESET}}$ is input.)
0	1	Sets all outputs to High	*All-display lights ON command has priority.
1	1	Sets all outputs to High	

F. Standby mode  
(Turning off all display-lights and stopping oscillation function)

This mode turns off all display-lights (fixing COM at Low) and stops oscillation function. This completely stops the internal operation of the ML9203 and attains low power consumption of  $V_{DD}$  and  $V_{DISP}$ .

Note: If the  $\overline{RESET}$  signal is input while the standby mode is in progress, the standby mode is released and all states are initialized.

[Command format]

	LSB				MSB				
	B0	B1	B2	B3	B4	B5	B6	B7	
1st byte	*	*	*	*	1	1	1	1	: selects the Standby mode

\* : Don't care

[Releasing the Standby mode]

The timing to release the standby mode is shown below. The standby mode is released at the falling edge of  $\overline{CS}$ . (The oscillator starts oscillation.)

When the oscillation becomes stable, the data input is enabled. (Return  $\overline{CS}$  to high before entering data.)

After the standby mode is released, all display-lights are turned off. Release the all display-lights OFF mode to turn on the display-lights.

Note: Do not input shift clock to  $\overline{CP}$  before the oscillation becomes stable. (If done, data will be given.)

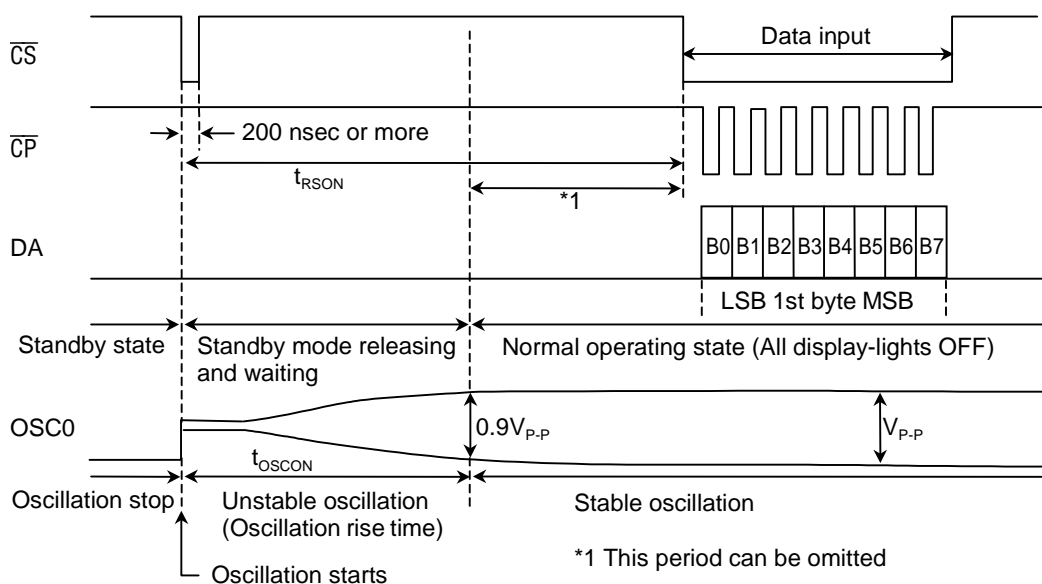

Note: The oscillation rise time " $t_{OSCON}$ " is dependent upon the type of the used oscillator. For more information of the oscillation rise time, see the data on the oscillator used.

**Setting Flowchart  
(Power applying included)**

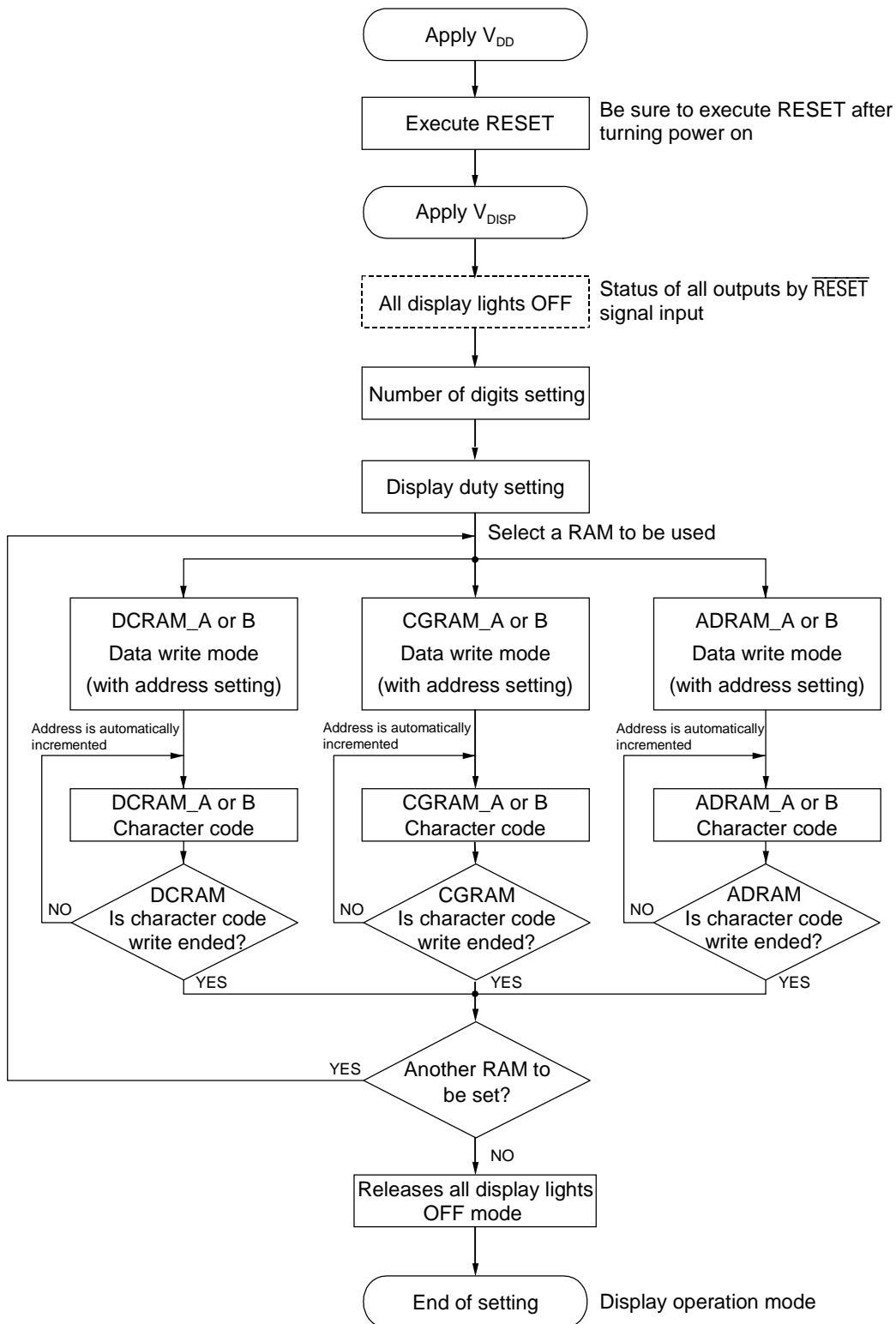

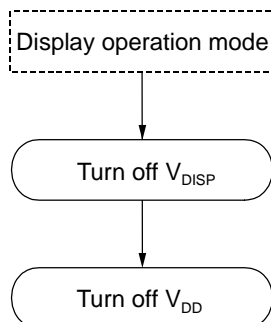
**Power-off Flowchart**

## APPLICATION CIRCUIT

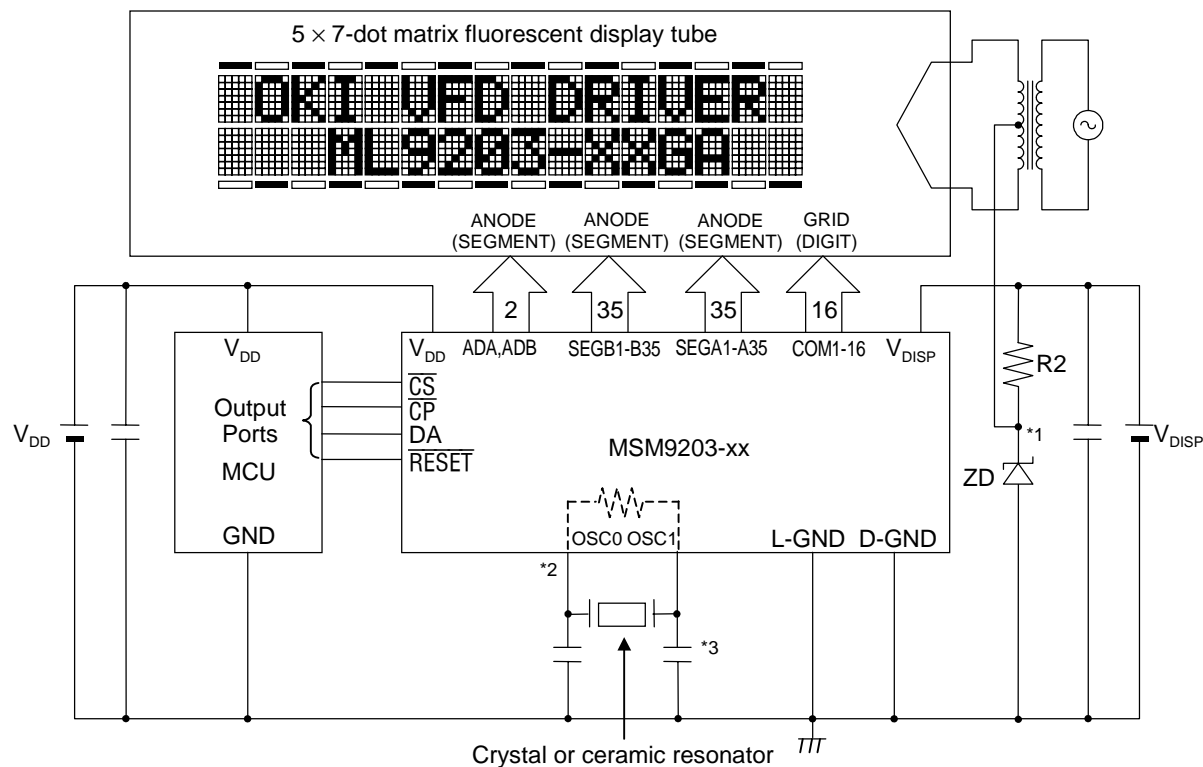

\*1 The  $V_{DISP}$  voltage depends on the fluorescent display tube used. Adjust the value of the constants  $R_2$  and ZD to the  $V_{DISP}$  voltage used.

\*2 The wiring trace between the OSC0 pin and the resonator should be kept as short as possible, and the GND traces should be provided along both sides of the wiring trace.

\*3 Adjust the capacitance of a capacitor depending on the type of an oscillator used. (Refer to data on an oscillator used.)

**Reference data**

Graphs illustrating the  $V_{DISP}$  versus driver output current capability relationship are shown below. Care must be taken not to use the total power in excess of allowable power dissipation.

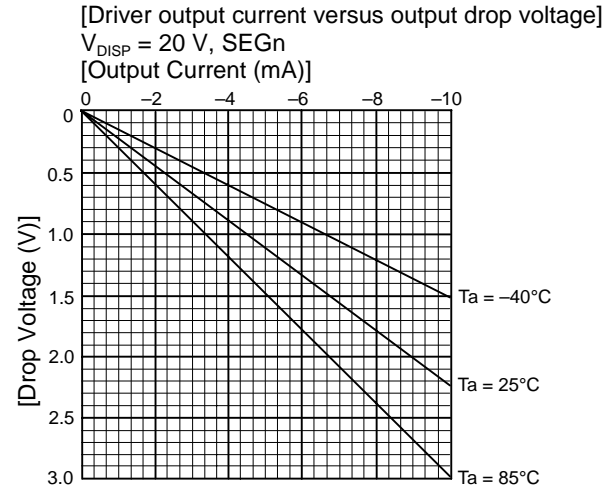
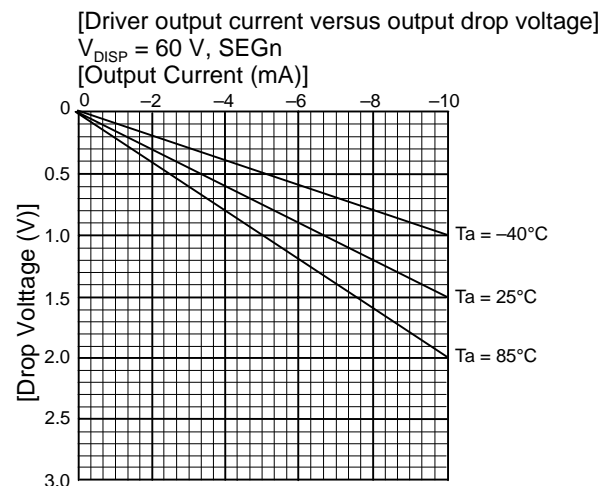
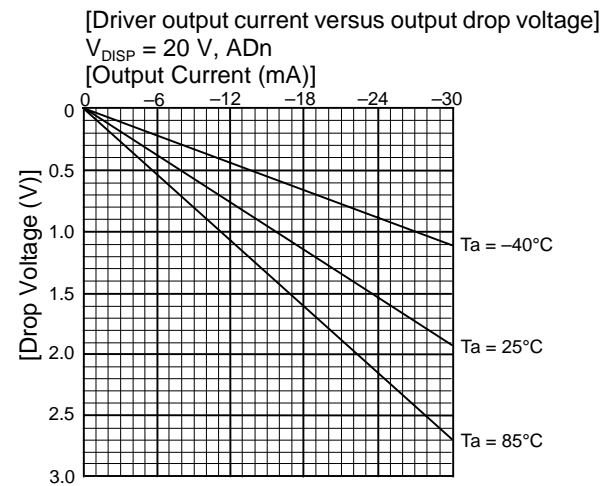
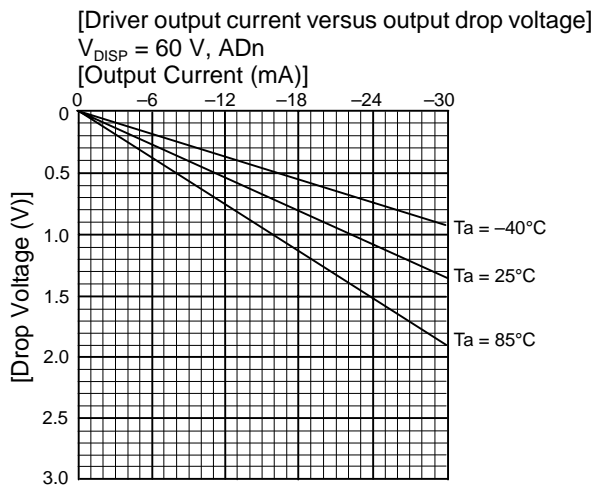
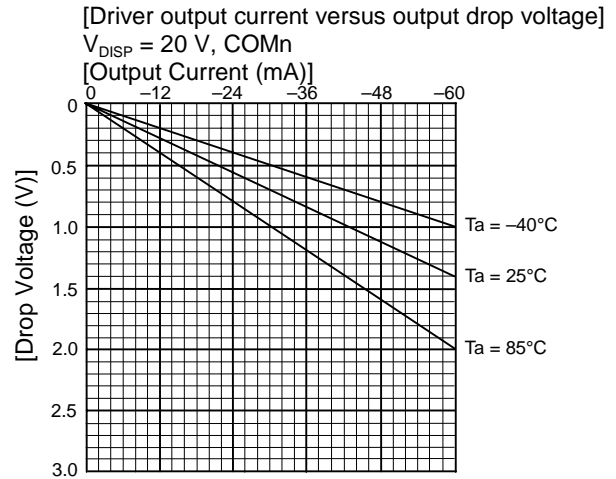
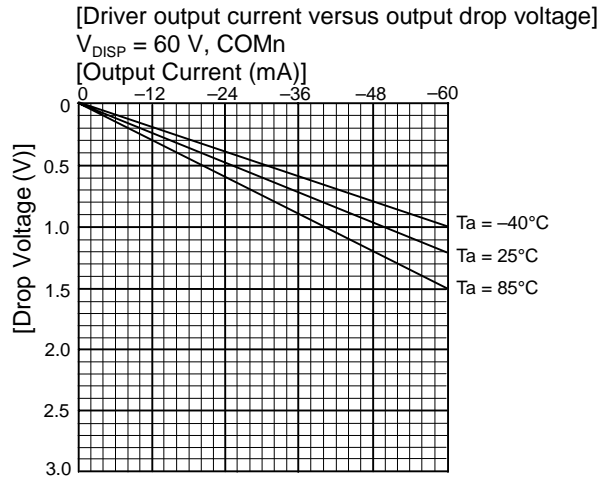

**ML9203-01 CGROM\_A CODE**

00000000B (00H) to 00000111B (0FH) are the CGRAM\_A addresses.

MSB LSB	0000	0001	0010	0011	0100	0101	0110	0111	1000	1001	1010	1011	1100	1101	1110	1111
0000	RAM00															
0001	RAM01															
0010	RAM02															
0011	RAM03															
0100	RAM04															
0101	RAM05															
0110	RAM06															
0111	RAM07															
1000	RAM08															
1001	RAM09															
1010	RAM0A															
1011	RAM0B															
1100	RAM0C															
1101	RAM0D															
1110	RAM0E															
1111	RAM0F															

**ML9203-01 CGROM\_B CODE**

0000000B (00H) to 00000111B (0FH) are the CGRAM\_B addresses.

MSB LSB	0000	0001	0010	0011	0100	0101	0110	0111	1000	1001	1010	1011	1100	1101	1110	1111
0000 RAM00																
0001 RAM01																
0010 RAM02																
0011 RAM03																
0100 RAM04																
0101 RAM05																
0110 RAM06																
0111 RAM07																
1000 RAM08																
1001 RAM09																
1010 RAM0A																
1011 RAM0B																
1100 RAM0C																
1101 RAM0D																
1110 RAM0E																
1111 RAM0F																

**PACKAGE DIMENSIONS**

(Unit: mm)

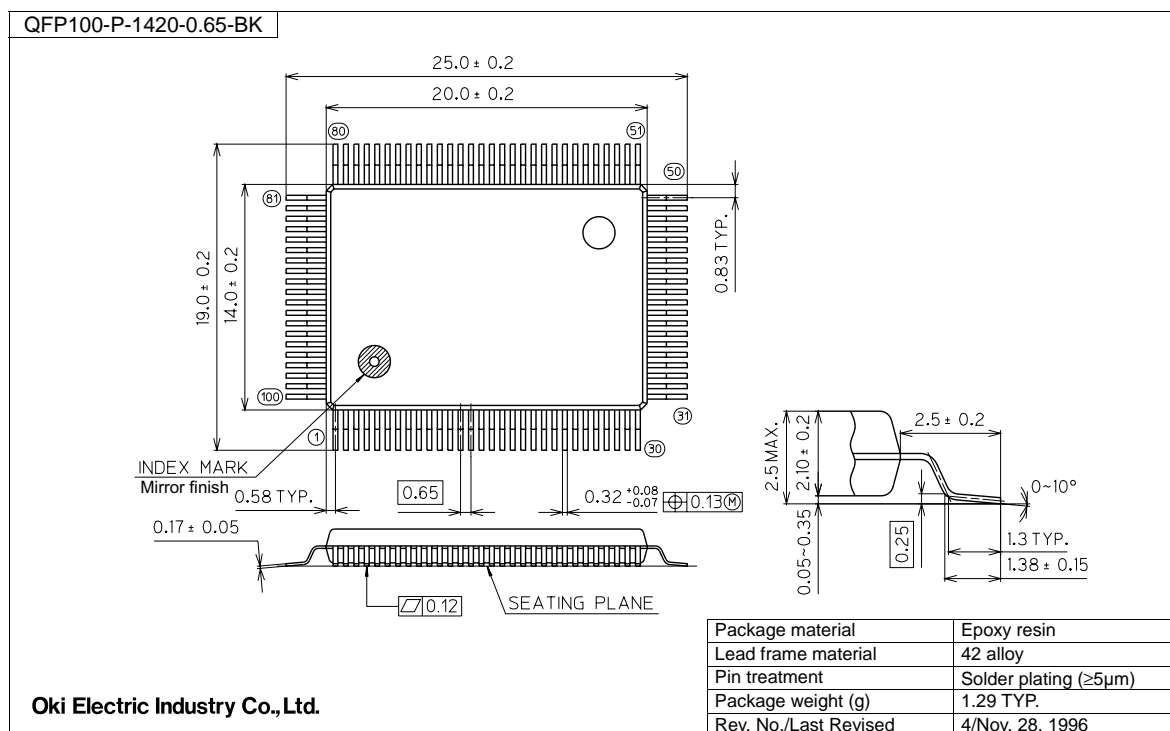

**Notes for Mounting the Surface Mount Type Package**

The surface mount type packages are very susceptible to heat in reflow mounting and humidity absorbed in storage. Therefore, before you perform reflow mounting, contact Oki's responsible sales person for the product name, package name, pin number, package code and desired mounting conditions (reflow method, temperature and times).

**NOTICE**

1. The information contained herein can change without notice owing to product and/or technical improvements. Before using the product, please make sure that the information being referred to is up-to-date.
2. The outline of action and examples for application circuits described herein have been chosen as an explanation for the standard action and performance of the product. When planning to use the product, please ensure that the external conditions are reflected in the actual circuit, assembly, and program designs.
3. When designing your product, please use our product below the specified maximum ratings and within the specified operating ranges including, but not limited to, operating voltage, power dissipation, and operating temperature.
4. Oki assumes no responsibility or liability whatsoever for any failure or unusual or unexpected operation resulting from misuse, neglect, improper installation, repair, alteration or accident, improper handling, or unusual physical or electrical stress including, but not limited to, exposure to parameters beyond the specified maximum ratings or operation outside the specified operating range.
5. Neither indemnity against nor license of a third party's industrial and intellectual property right, etc. is granted by us in connection with the use of the product and/or the information and drawings contained herein. No responsibility is assumed by us for any infringement of a third party's right which may result from the use thereof.
6. The products listed in this document are intended for use in general electronics equipment for commercial applications (e.g., office automation, communication equipment, measurement equipment, consumer electronics, etc.). These products are not authorized for use in any system or application that requires special or enhanced quality and reliability characteristics nor in any system or application where the failure of such system or application may result in the loss or damage of property, or death or injury to humans. Such applications include, but are not limited to, traffic and automotive equipment, safety devices, aerospace equipment, nuclear power control, medical equipment, and life-support systems.
7. Certain products in this document may need government approval before they can be exported to particular countries. The purchaser assumes the responsibility of determining the legality of export of these products and will take appropriate and necessary steps at their own expense for these.
8. No part of the contents contained herein may be reprinted or reproduced without our prior permission.

Copyright 2001 Oki Electric Industry Co., Ltd.