

DCR818SG

PHASE CONTROL THYRISTOR

APPLICATIONS

- High Power Drives.
- High Voltage Power Supplies.
- DC Motor Control.
- Welding.
- Battery Chargers.

KEY PARAMETERS

V_{DRM}	4800V
$I_{T(AV)}$	425A
I_{TSM}	7500A
dV/dt^*	1600V/μs
di/dt	150A/μs

*Higher dV/dt selections available

FEATURES

- Double Side Cooling.
- High Surge Capability.

VOLTAGE RATINGS

Type Number	Repetitive Peak Voltages V_{DRM} V_{RRM} V	Conditions
DCR818SG48	4800	$T_{vj} = 0^\circ$ to 125° C, $I_{DRM} = I_{RRM} = 75mA$, $V_{DRM}, V_{RRM} t_p = 10ms$, V_{DSM} & $V_{RSM} =$ V_{DRM} & $V_{RRM} + 100V$ Respectively
DCR818SG47	4700	
DCR818SG46	4600	
DCR818SG45	4500	
DCR818SG44	4400	

Lower voltage grades available.

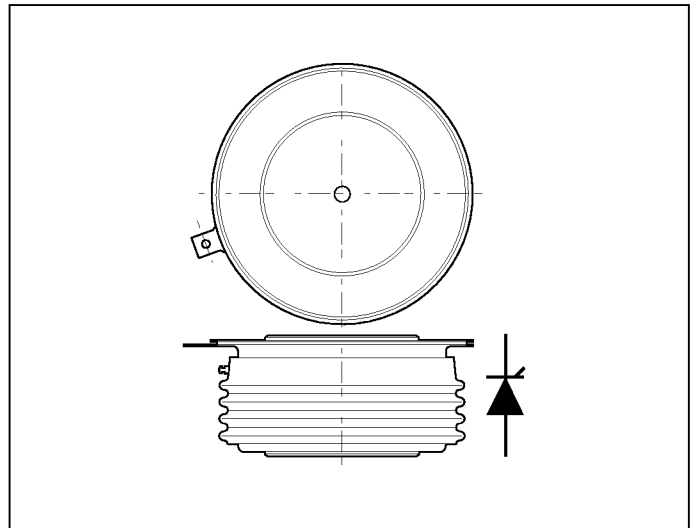

Outline type code: G. See package outline for further information.

CURRENT RATINGS

Symbol	Parameter	Conditions	Max.	Units
Double Side Cooled				
$I_{T(AV)}$	Mean on-state current	Half wave resistive load, $T_{case} = 80^\circ$ C	425	A
$I_{T(RMS)}$	RMS value	$T_{case} = 80^\circ$ C	667	A
I_T	Continuous (direct) on-state current	$T_{case} = 80^\circ$ C	595	A
Single Side Cooled (Anode side)				
$I_{T(AV)}$	Mean on-state current	Half wave resistive load, $T_{case} = 80^\circ$ C	285	A
$I_{T(RMS)}$	RMS value	$T_{case} = 80^\circ$ C	447	A
I_T	Continuous (direct) on-state current	$T_{case} = 80^\circ$ C	360	A

DCR818SG

SURGE RATINGS

Symbol	Parameter	Conditions	Max.	Units
I_{TSM}	Surge (non-repetitive) on-state current	10ms half sine; $T_{case} = 125^{\circ}C$	6.0	kA
I^2t	I^2t for fusing	$V_R = 50\% V_{RRM}$ - 1/4 sine	0.18×10^6	A ² s
I_{TSM}	Surge (non-repetitive) on-state current	10ms half sine; $T_{case} = 125^{\circ}C$	7.5	kA
I^2t	I^2t for fusing	$V_R = 0$	0.28×10^6	A ² s

THERMAL AND MECHANICAL DATA

Symbol	Parameter	Conditions	Min.	Max.	Units	
$R_{th(j-c)}$	Thermal resistance - junction to case	Double side cooled	dc	-	0.032	$^{\circ}C/W$
		Single side cooled	Anode dc	-	0.064	$^{\circ}C/W$
			Cathode dc	-	0.064	$^{\circ}C/W$
$R_{th(c-h)}$	Thermal resistance - case to heatsink	Clamping force 11.0kN with mounting compound	Double side	-	0.008	$^{\circ}C/W$
			Single side	-	0.016	$^{\circ}C/W$
T_{vj}	Virtual junction temperature	On-state (conducting)		-	135	$^{\circ}C$
		Reverse (blocking)		-	125	$^{\circ}C$
T_{slg}	Storage temperature range		-55	125	$^{\circ}C$	
-	Clamping force		10.8	13.2	kN	

DYNAMIC CHARACTERISTICS

Symbol	Parameter	Conditions	Typ.	Max.	Units	
I_{RRM}/I_{DRM}	Peak reverse and off-state current	At V_{RRM}/V_{DRM} , $T_{case} = 125^{\circ}C$	-	75	mA	
dV/dt	Maximum linear rate of rise of off-state voltage	To 67% V_{DRM} , $T_j = 125^{\circ}C$.	-	1600	V/ μ s	
di/dt	Rate of rise of on-state current	From 67% V_{DRM} to 1000A Gate source 20V, 10 Ω $t_r \leq 0.5\mu$ s, $T_j = 125^{\circ}C$.	Repetitive 50Hz	-	75	A/ μ s
			Non-repetitive	-	150	A/ μ s
$V_{T(TO)}$	Threshold voltage	At $T_{vj} = 125^{\circ}C$	-	1.4	V	
r_T	On-state slope resistance	At $T_{vj} = 125^{\circ}C$	-	1.7	m Ω	
t_{gd}	Delay time	$V_D = 67\% V_{DRM}$, Gate source 30V, 15 Ω Rise time 0.5 μ s, $T_j = 25^{\circ}C$	-	1.7	μ s	
I_L	Latching current	$T_j = 25^{\circ}C$, $V_D = 5V$, Gate source = 20V, 10 Ω	100	1000	mA	
I_H	Holding current	$T_j = 25^{\circ}C$, $R_{g-k} = \infty$	60	500	mA	
t_q	Turn-off time	$I_T = 1000A$, $t_p = 1ms$, $T_j = 125^{\circ}C$, $V_{RM} = 100V$, $dI_{RR}/dt = 10A/\mu$ s, $dV_{DR}/dt = 20V/\mu$ s to 3000V	450	-	μ s	

GATE TRIGGER CHARACTERISTICS AND RATINGS

Symbol	Parameter	Conditions	Max.	Units
V_{GT}	Gate trigger voltage	$V_{DRM} = 5V$, $T_{case} = 25^{\circ}C$	3.0	V
I_{GT}	Gate trigger current	$V_{DRM} = 5V$, $T_{case} = 25^{\circ}C$	300	mA
V_{GD}	Gate non-trigger voltage	At V_{DRM} , $T_{case} = 125^{\circ}C$	0.25	V
V_{FGM}	Peak forward gate voltage	Anode positive with respect to cathode	30	V
V_{FGN}	Peak forward gate voltage	Anode negative with respect to cathode	0.25	V
V_{RGM}	Peak reverse gate voltage		5	V
I_{FGM}	Peak forward gate current	Anode positive with respect to cathode	10	A
P_{GM}	Peak gate power	See table, fig.4	150	W
$P_{G(AV)}$	Mean gate power		5	W

CURVES

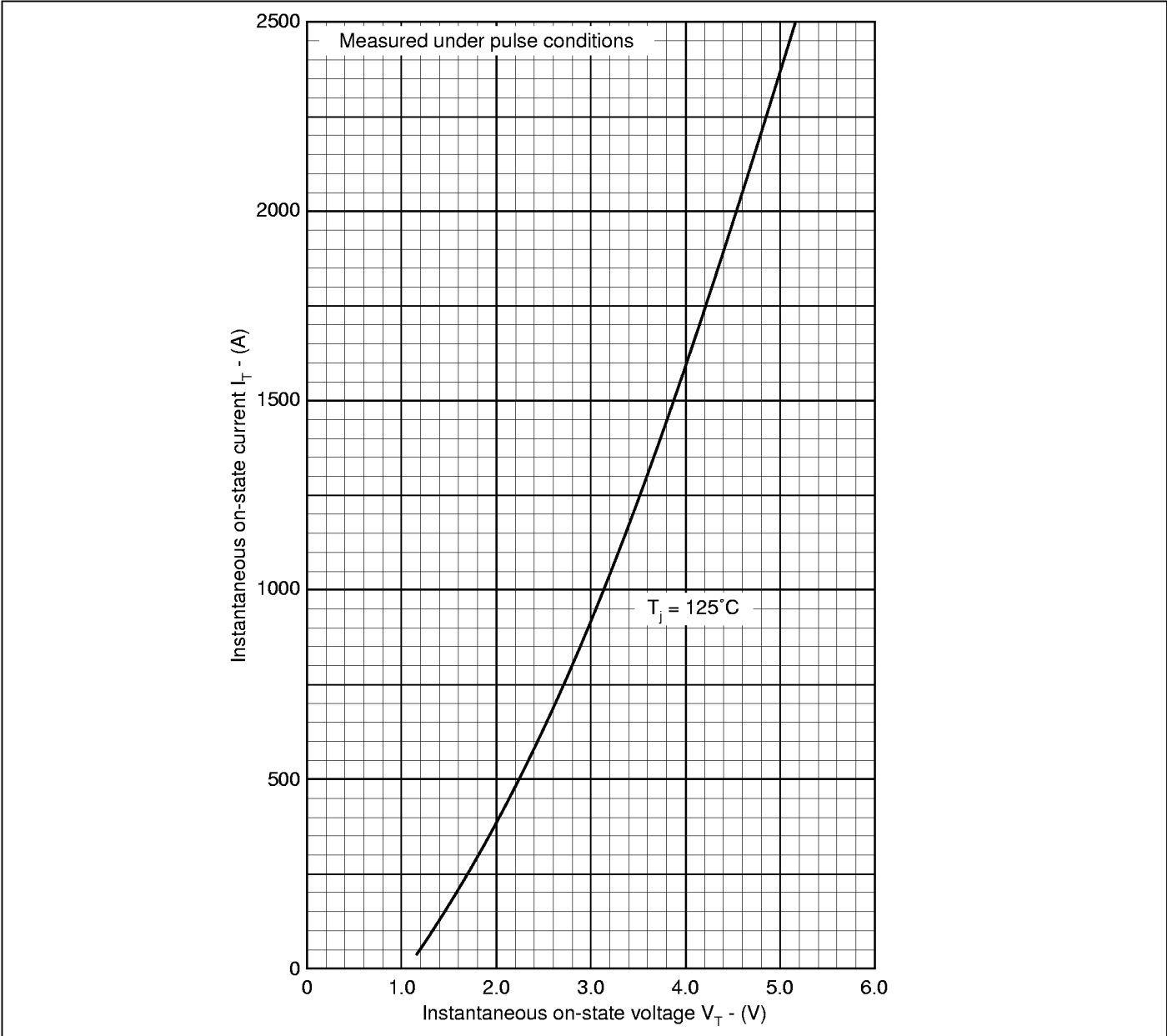

Fig.1 Maximum (limit) on-state characteristics

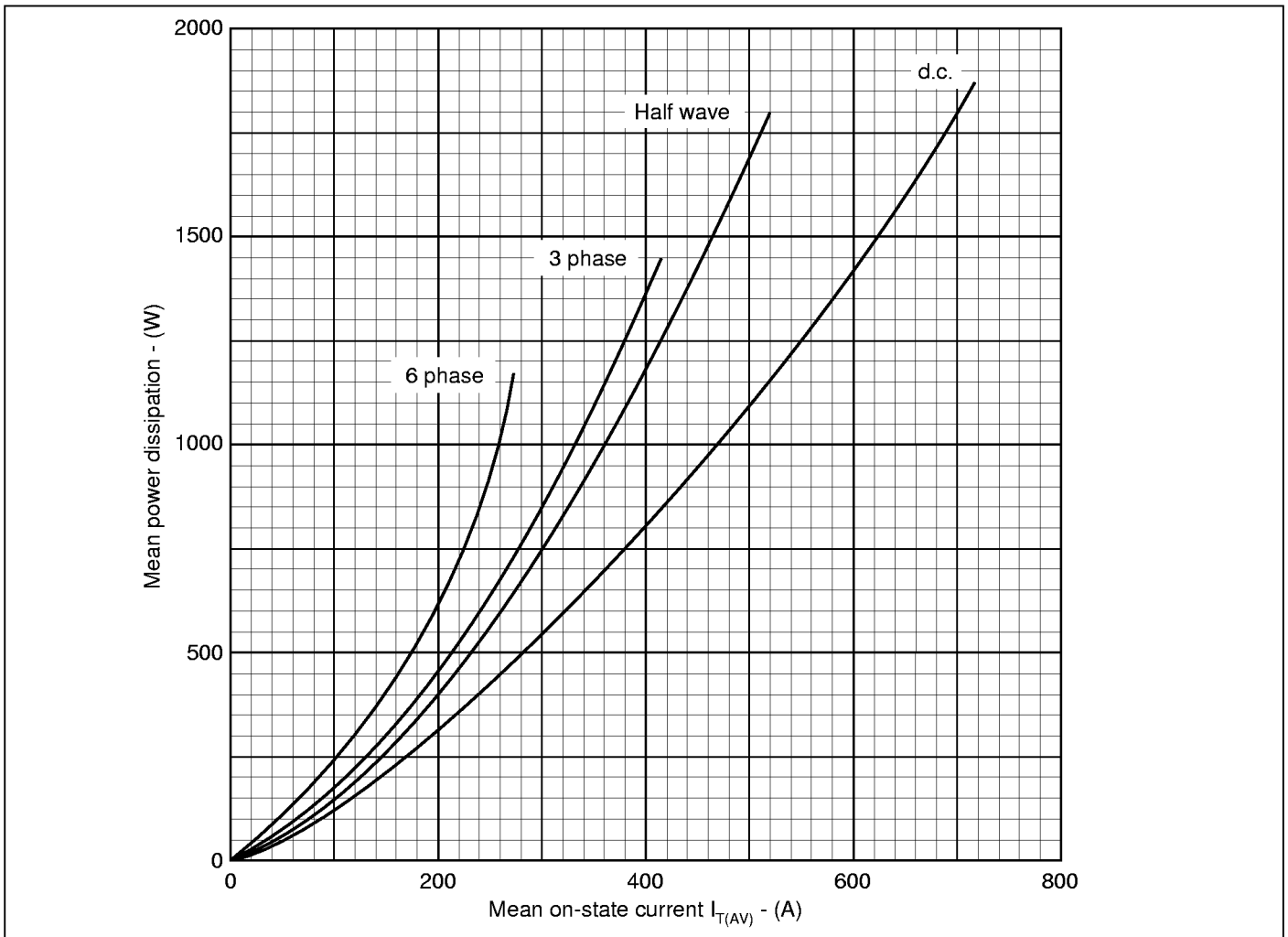

Fig.2 Dissipation curves

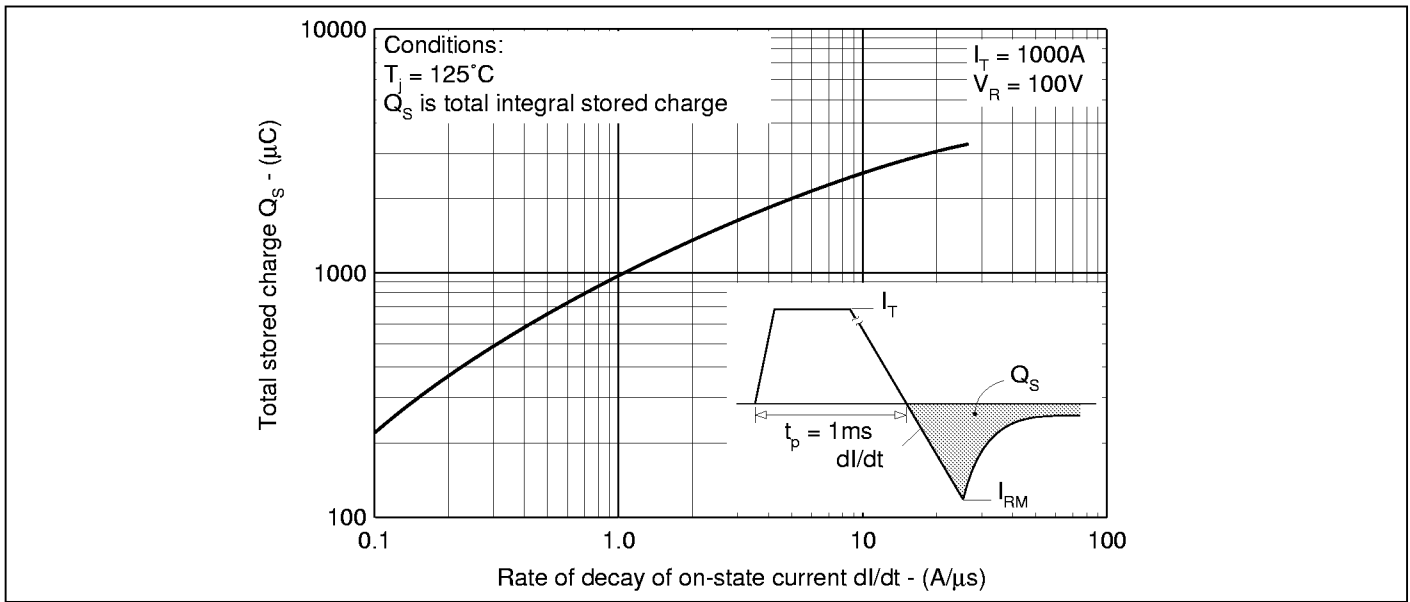

Fig.3 Stored charge

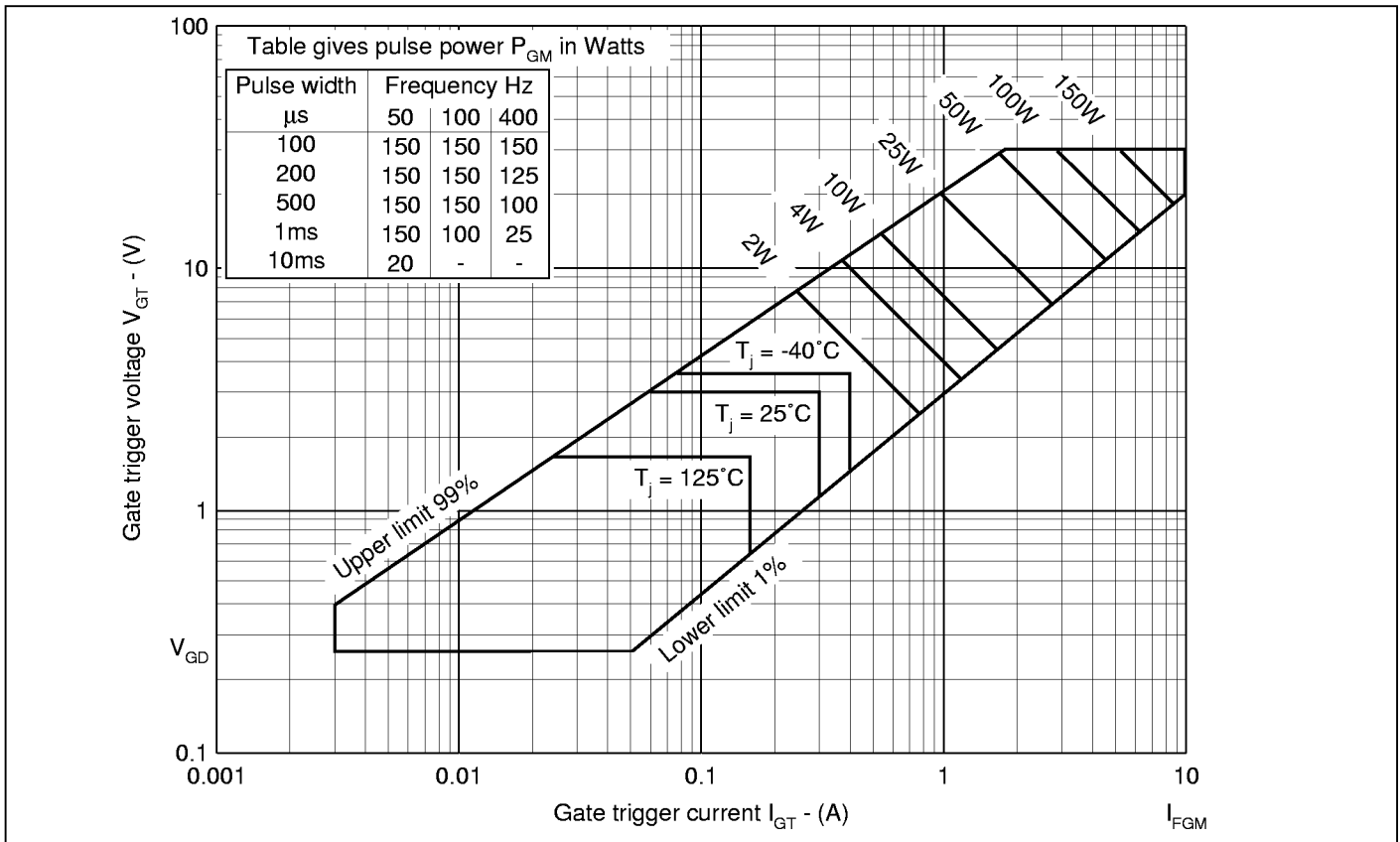

Fig.4 Gate characteristics

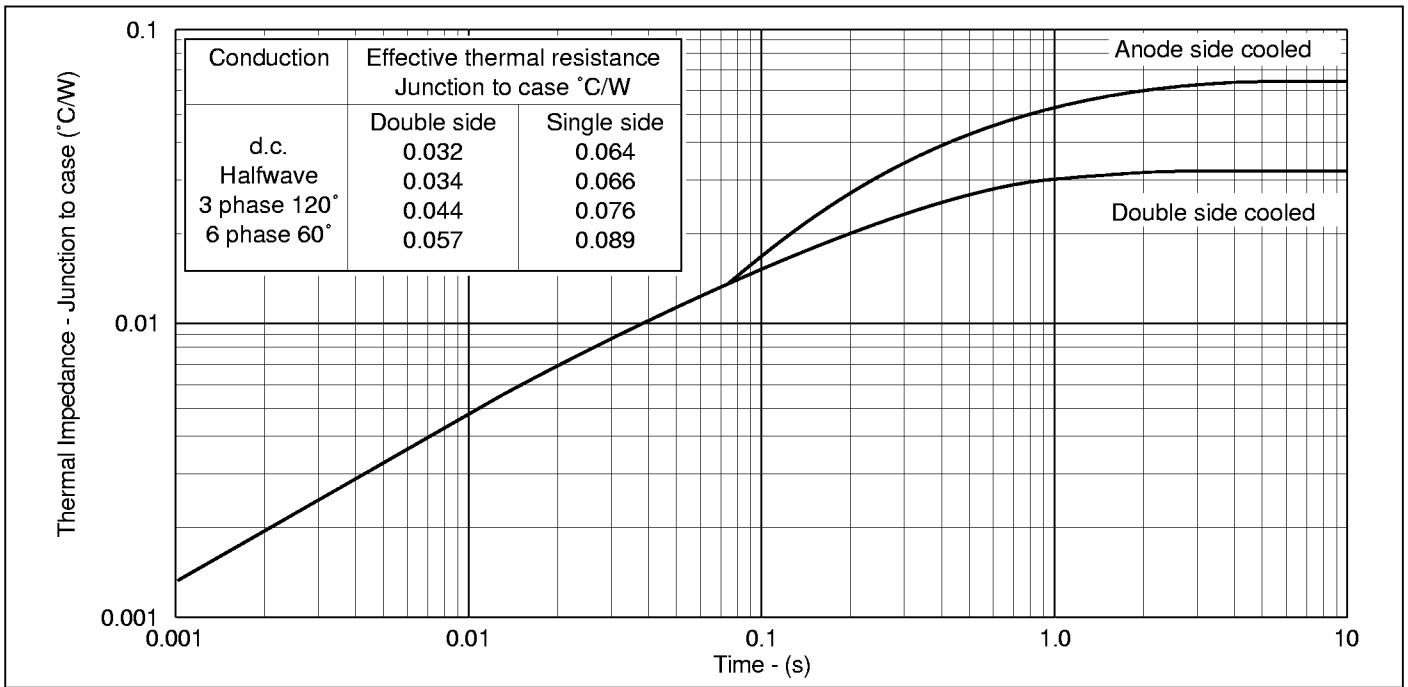

Fig.5 Transient thermal impedance - junction to case - (°C/W)

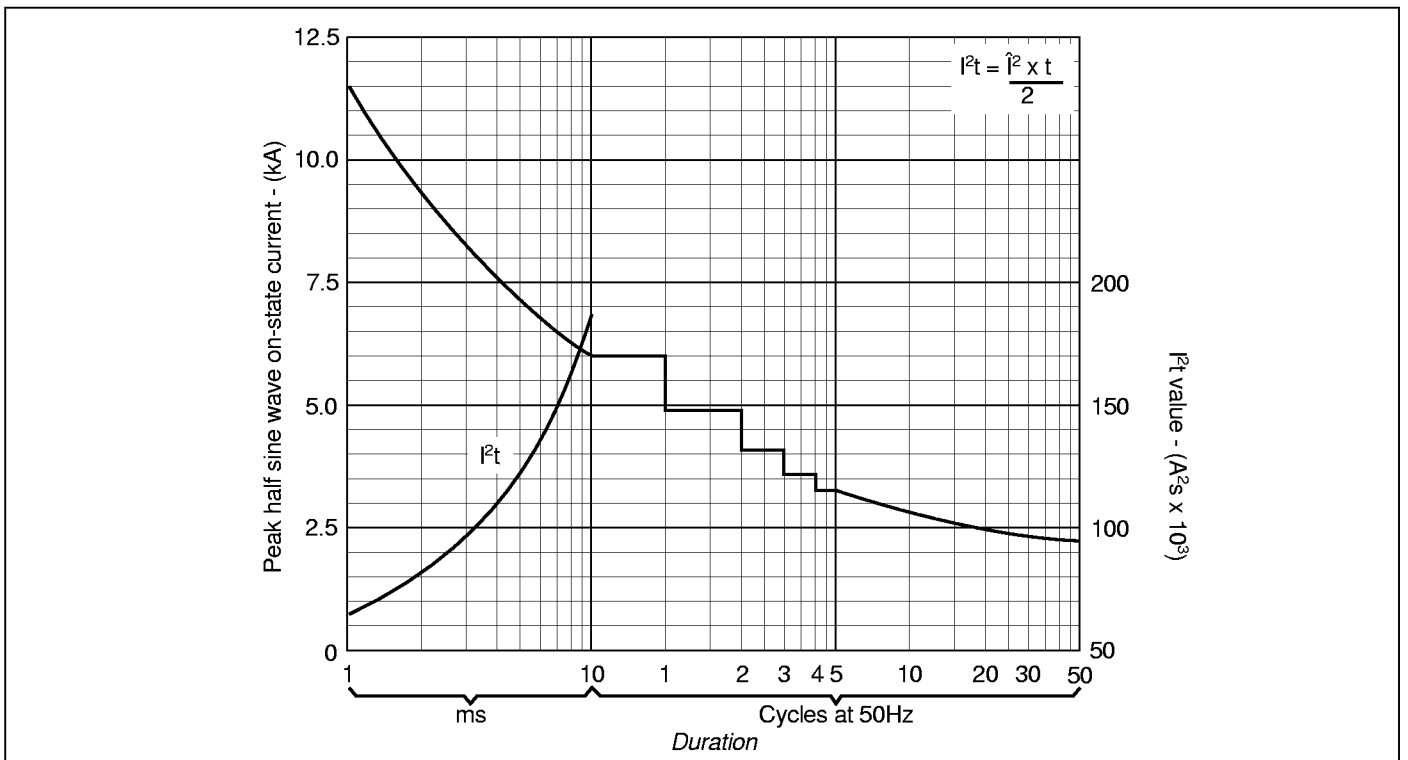
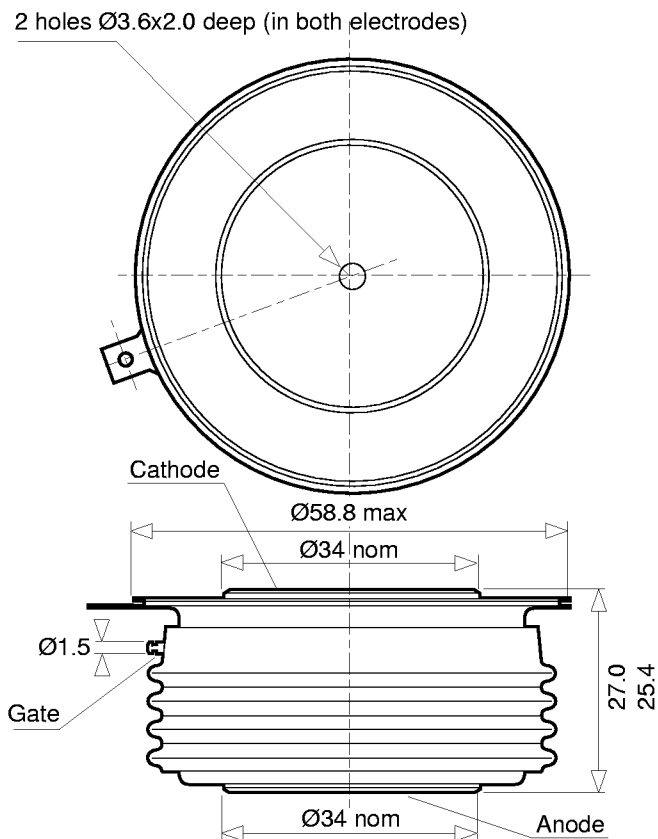

Fig.6 Surge (non-repetitive) on-state current vs time (with 50% V_{RRM} at $T_{case} = 125^{\circ}C$)

DCR818SG

PACKAGE OUTLINE - G

For further package information, please contact your local Customer Service Centre. All dimensions in mm, unless stated otherwise. DO NOT SCALE.



Weight: 310g



HEADQUARTERS OPERATIONS
GEC PLESSEY SEMICONDUCTORS
Cheney Manor, Swindon,
Wiltshire, SN2 2QW, United Kingdom.
Tel: + 44 (0)1793 518000
Fax: + 44 (0)1793 518411

GEC PLESSEY SEMICONDUCTORS
P.O. Box 660017
1500 Green Hills Road,
Scotts Valley, California 95066-4922,
United States of America.
Tel: + 1 (408) 438 2900
Fax: + 1 (408) 438 5576/6231

<http://www.gpsemi.com>

POWER PRODUCT CUSTOMER SERVICE CENTRES

- **FRANCE, BENELUX & SPAIN.** 2 rue Henri-Bergson, 92665 Asnieres Cedex.
Tel: + 33 1 40 80 54 00. Fax: + 33 1 40 80 55 87.
- **GERMANY.** Ungererstrasse 129, 80505 München.
Tel: + 49 (0)89 36 09 060. Fax: + 49 (0)89 36 09 06 55.
- **NORTH AMERICA.** At Dedham Place, Suite 125, 3 Allied Drive, Dedham. MA 02026.
Tel: + 1 617 251 0126. Fax: + 1 617 251 0106.
- **UNITED KINGDOM.** Doddington Road, Lincoln. LN6 3LF.
Tel: + 44 (0)1522 500500. Fax: + 44 (0)1522 510550.

These are supported by Agents and Distributors in major countries world-wide.

© GEC Plessey Semiconductors 1997 Publication No. DS4241-4 Issue 4.2 June 1997
TECHNICAL DOCUMENTATION - NOT FOR RESALE. PRINTED IN UNITED KINGDOM.

This publication is issued to provide information only which (unless agreed by the Company in writing) may not be used, applied or reproduced for any purpose nor form part of any order or contract nor to be regarded as a representation relating to the products or services concerned. No warranty or guarantee express or implied is made regarding the capability, performance or suitability of any product or service. The Company reserves the right to alter without prior notice the specification, design or price of any product or service. Information concerning possible methods of use is provided as a guide only and does not constitute any guarantee that such methods of use will be satisfactory in a specific piece of equipment. It is the user's responsibility to fully determine the performance and suitability of any equipment using such information and to ensure that any publication or data used is up to date and has not been superseded. These products are not suitable for use in any medical products whose failure to perform may result in significant injury or death to the user. All products and materials are sold and services provided subject to the Company's conditions of sale, which are available on request.

All brand names and product names used in this publication are trademarks, registered trademarks or trade names of their respective owners.