

TA-NFKM



Type N Female to 4.1-9.5 DIN Male Low-PIM Adapter

Product Classification

Product Type Adapter

General Specifications

Body Style Straight
Inner Contact Plating Silver
Interface 4.1-9.5 DIN Male
Interface 2 N Female
Mounting Angle Straight
Outer Contact Plating Trimetal
Pressurizable No

Dimensions

Width 24 mm | 0.945 in
Length 35 mm | 1.378 in
Diameter 24 mm | 0.945 in

Outline Drawing

TA-NFKM

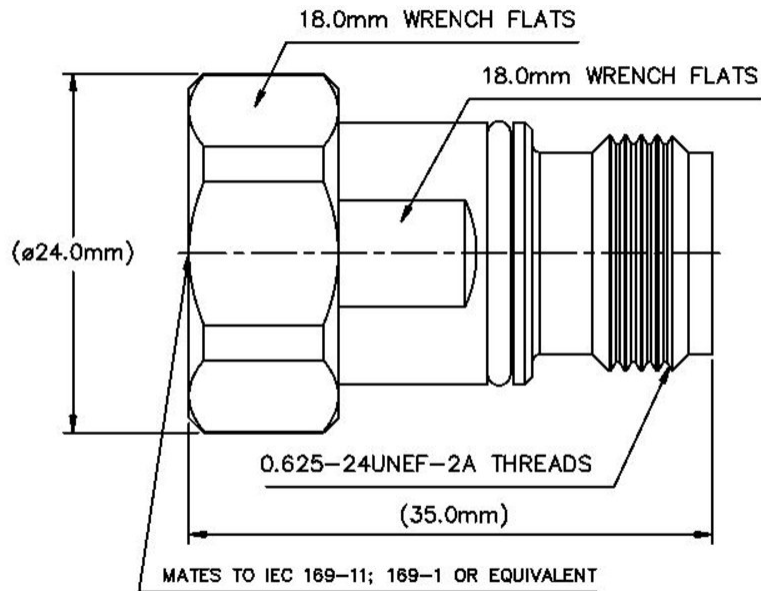

Electrical Specifications

3rd Order IMD at Frequency	-163 -dBc @ 1800 MHz
3rd Order IMD Test Method	Two +43 dBm carriers
Average Power at Frequency	600.0 W @ 900 MHz
Connector Impedance	50 ohm
dc Test Voltage	2500 V
Inner Contact Resistance, maximum	1.5 mOhm
Insulation Resistance, minimum	5000 MOhm
Operating Frequency Band	0 – 6000 MHz
Outer Contact Resistance, maximum	0.4 mOhm
Peak Power, maximum	10 kW
RF Operating Voltage, maximum (vrms)	707 V

VSWR/Return Loss

Frequency Band	VSWR	Return Loss (dB)
0-3000 MHz	1.04	36
3000-6000 MHz	1.09	28

TA-NFKM

Mechanical Specifications

Coupling Nut Proof Torque	15 N-m 132.761 in lb
Coupling Nut Retention Force	550 N 123.645 lbf
Coupling Nut Retention Force Method	IEC 61169-4:15.2.6
Insertion Force	27 N 6.07 lbf
Insertion Force Method	IEC 61169-16:9.3.5
Interface Durability	500 cycles
Mechanical Shock Test Method	IEC 60068-2-27

Environmental Specifications

Operating Temperature	-55 °C to +85 °C (-67 °F to +185 °F)
Storage Temperature	-65 °C to +125 °C (-85 °F to +257 °F)
Attenuation, Ambient Temperature	20 °C 68 °F
Average Power, Ambient Temperature	40 °C 104 °F
Average Power, Inner Conductor Temperature	100 °C 212 °F
Climatic Sequence Test Method	IEC 60068-1
Corrosion Test Method	IEC 60068-2-11
Damp Heat Steady State Test Method	IEC 60068-2-3
Thermal Shock Test Method	IEC 60068-2-14
Vibration Test Method	IEC 60068-2-6

Packaging and Weights

Weight, net	50.33 g 0.111 lb
--------------------	--------------------

Regulatory Compliance/Certifications

Agency	Classification
CHINA-ROHS	Below maximum concentration value
ISO 9001:2015	Designed, manufactured and/or distributed under this quality management system
REACH-SVHC	Compliant as per SVHC revision on www.commscope.com/ProductCompliance
ROHS	Compliant

