

**CRYSTAL CONTROLLED OSCILLATORS**

**14 PIN DIP 3.3V HCMOS STRATUM 3 OCXO**

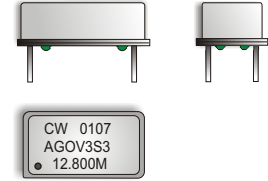

**ABSOLUTE MAXIMUM RATINGS**

**TABLE 1.0**

PARAMETER	UNITS	MINIMUM	NOMINAL	MAXIMUM	UNITS	NOTE
Storage Temperature		-40	-	85	°C	
Supply Voltage	(Vcc)	-0.5	-	4.5	Vdc	
Control Voltage	(Vc)	-0.5	-	4.5	Vdc	

**OPERATING SPECIFICATIONS**

**TABLE 2.0**

PARAMETER		MINIMUM	NOMINAL	MAXIMUM	UNITS	NOTE
Center Frequency	(Fo)		12.352 12.800 16.384 19.44 20.00		MHz	
Frequency Stability		-0.25	-	0.25	ppm	1
Total Frequency Tolerance		-4.6	-	4.6	ppm	2
Operating Temperature Range		0	-	70	°C	
Supply Voltage	(Vcc)	3.135	3.3	3.465	Vdc	
Supply Current	(Icc)	-	-	400	mA	
Jitter (BW=12kHz to 20MHz)		-	-	5	ps rms	
SSB Phase Noise at 10Hz offset		-	-75	-	dBc/Hz	
SSB Phase Noise at 10KHz offset		-	-130	-	dBc/Hz	
Start Up Time: Oscillator		-	-	10	mS	
Warm Up Time		-	-	5	Minutes	3
TDEV @ 1.0 Sec.		-	-	1	nS	
TDEV @ 4.0 Sec.		-	-	2	nS	

**INPUT CHARACTERISTICS**

**TABLE 3.0**

PARAMETER		MINIMUM	NOMINAL	MAXIMUM	UNITS	NOTE
Control Voltage Range	(Vc)	0.3	1.48	3.0	Vdc	
Frequency at Vc=0.3 Vdc		-22.5	-	-13.5	ppm	
Frequency at Vc=3.0 Vdc		13.5	-	22.5	ppm	4
Slope of Frequency Adjust		5	-	-	ppm/V	
Input Impedance		100k	-	-	Ohm	

**HCMOS OUTPUT CHARACTERISTICS**

**TABLE 4.0**

PARAMETER		MINIMUM	NOMINAL	MAXIMUM	UNITS	NOTE
LOAD		-	-	15	pf	
Voltage (High)	(Voh)	2.6	-	-	Vdc	
(Low)	(Vol)	-	-	0.4	Vdc	
Current (High)	(Ioh)	-4	-	-	mA	
(Low)	(Iol)	-	-	4	mA	
Duty Cycle at 50% of Vcc		45	50	55	%	
Rise / Fall Time 10% to 90%		-	-	6	nS	

**PACKAGE CHARACTERISTICS**

**TABLE 5.0**

Package	14 pin DIP, hermetically sealed, grounded case, welded package
---------	--

**Notes:**

- 1) Frequency vs. temperature stability, Vc = 1.48V.
- 2) Inclusive of calibration, operating temperature range, supply voltage change, load change, shock and vibration, 10 years aging, Vc = 1.48V.
- 3) Measured @ 25 °C, within 5 minutes, the unit will be within +/-5ppm of its reference frequency, measured after 30 minutes of continuous operation at a stable 25 °C
- 4) Referenced to Fo @ 25°C, Positive Transfer Characteristic

**AGOV3S3**

**DESCRIPTION**

The Connor-Winfield AGOV3S3 is a hermetically sealed 14 Pin DIP 3.3V Oven Controlled Crystal Oscillator (OCXO) with an HCMOS output. The AGOV3S3 is designed for Stratum 3 applications requiring low jitter and tight

**FEATURES**

- FREQUENCY ADJUST
- 3.3V OPERATION
- LOW JITTER <5ps RMS
- TEMPERATURE STABILITY ±0.25ppm
- FREQUENCY TOLERANCE OF ±4.6ppm OVER TEN YEARS

**ORDERING INFORMATION**

**AGOV3S3 - 12.800MHZ**

OCXO  
SERIES

CENTER  
FREQUENCY

Specifications subject to change without notice.

**CRYSTAL CONTROLLED OSCILLATORS**

PACKAGE OUTLINE

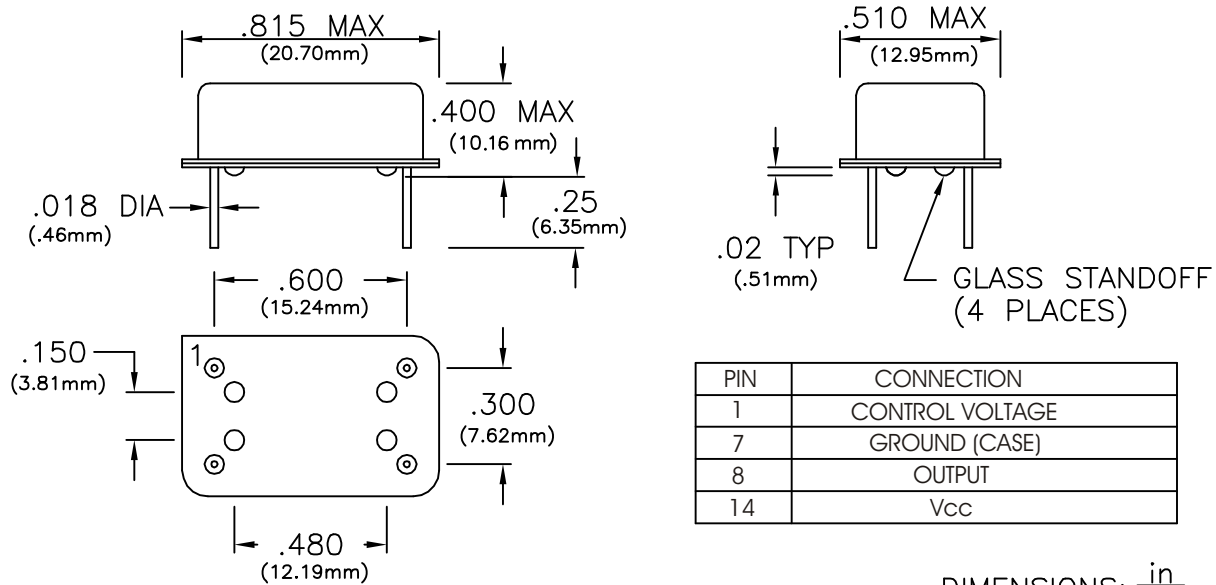

DIMENSIONS:  $\frac{\text{in}}{\text{mm}}$

TEST DIAGRAM

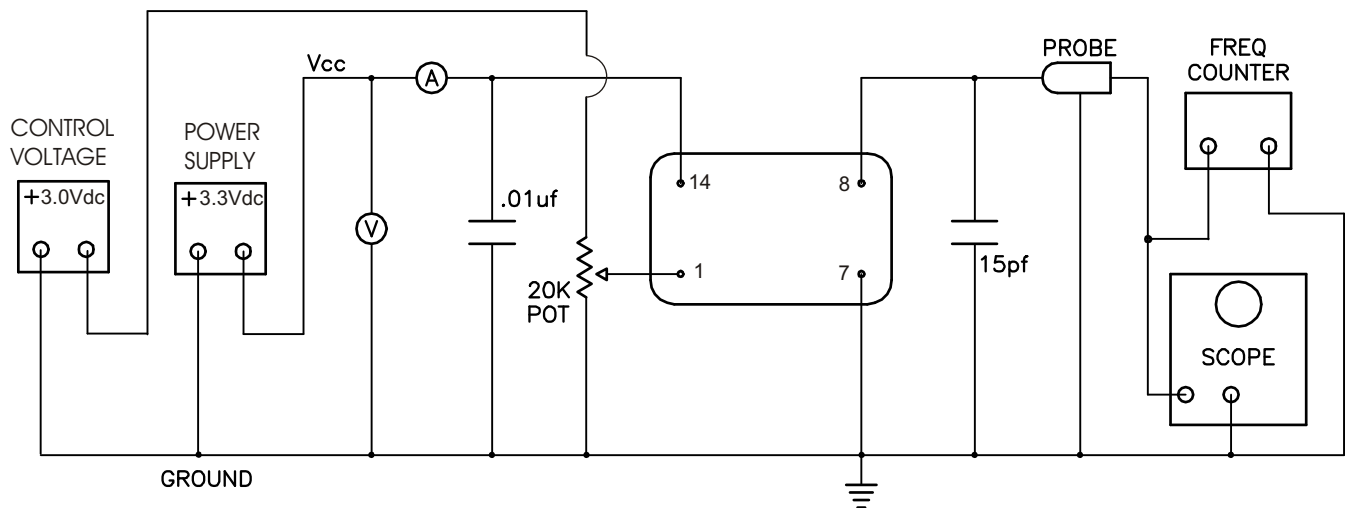

Specifications subject to change without notice.