



MU9C8148 SRT Interface

DISTINCTIVE CHARACTERISTICS

- Supports High-speed Source Routing or Source Routing Transparent Bridging for up to eight ports
- Glue-free operation with the MUSIC MU9C1480 LANCAM and Texas Instruments' Token Ring chip set
- Configurable for either Motorola or Intel processor addressing modes
- Complies with the IEEE standards for 4 and 16 Mb/s Token Ring
- Contains a 128-entry Instruction Buffer that holds up to seven down-loadable filtering and purging routines, which can be automatically or directly invoked
- Automatically selects Source Routed or Transparent filtering routines based on Transceiver output data, and supplies the proper Match, Fail, or Flush signals to the MAC chips
- Built-in arbitration allows two MU9C8148s to share a central LANCAM database
- Selectable filtering options for each frame type
- Frame validity is checked on all Routing Information Fields
- Manufactured in CMOS technology
- Available in 68-pin PLCC package and 80-pin TQFP package

GENERAL DESCRIPTION

The MU9C8148 is a Source Routing Transparent (SRT) Interface for the MUSIC Semiconductors MU9C1480 LANCAM for use in Token Ring LAN Bridges and Routers. This interface operates in accordance with IEEE standards while supporting address filtering rates up to 150,000 frames/sec for minimum-length frames.

The MU9C8148 has four interfaces to provide glue-free address filtering. The Transceiver interface monitors receive data from the Transceiver to the MAC, and determines whether to filter according to Source Routing or Transparent Bridging standards. The MAC interface supplies Match, Fail, and Flush signals to instruct the Token Ring controller to reject or copy a frame. The LANCAM interface controls the companion LANCAM(s) for Transparent filtering. The Host Processor interface allows for direct initialization of the MU9C8148, and downloading of the filtering and purging routines, to offload the communication processor.

The MU9C8148 can choose to copy or reject a frame depending on the frame type (MAC, LLC, or reserved), and can perform multiple validity checks on the Routing Information Field (RIF), including general checks on every Routing Control Field (RCF), as well as multiple frame related checks.

The Instruction Buffer can be loaded with up to 128 instructions at initialization for the LANCAM routines such as matching, learning, aging, purging, and data buffering operations. Internal arbitration controls access to the LANCAM. Separate arbitration pins allow two MU9C8148s to easily form a dual-port Bridge by sharing a central LANCAM-based station list.

With seven Ring-Bridge-Ring number combinations stored internally, the MU9C8148 can also operate as a source routing accelerator in multi-port Token Ring Bridge/Router environments.

BLOCK DIAGRAM

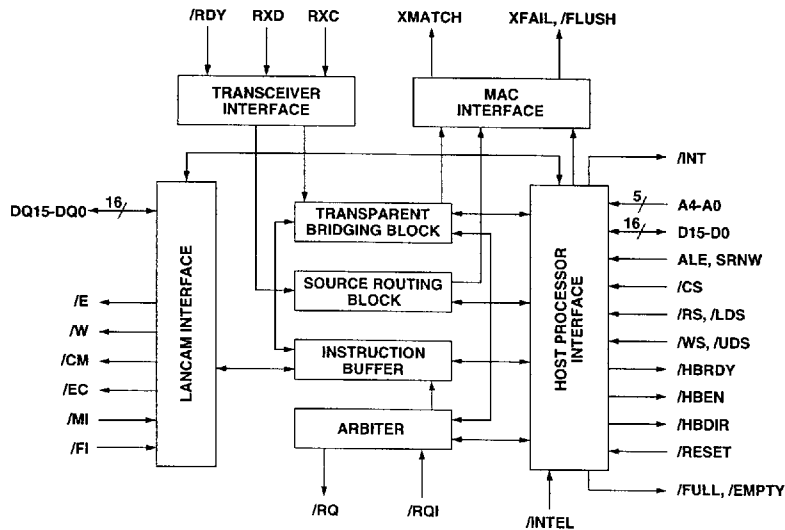

LANCAM, the MUSIC logo, and the phrase "MUSIC Semiconductors" are registered trademarks of MUSIC Semiconductors. MUSIC is a trademark of MUSIC Semiconductors. This device takes advantage of features in the LANCAM patented under U.S. Patent 5,383,146.

15 April 1997 Rev. 5.5 Draft Web

MU9C8148

PINOUT DIAGRAMS

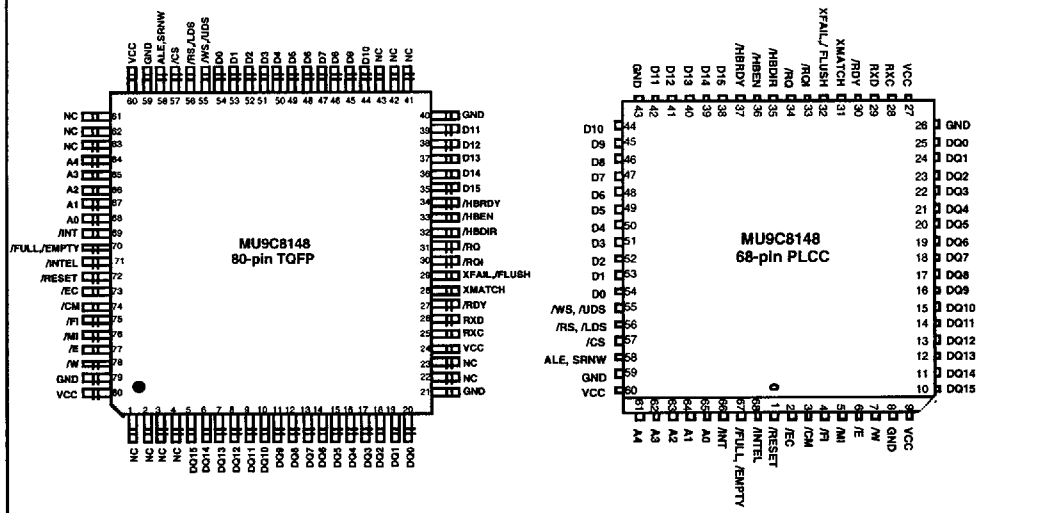

PIN DESCRIPTIONS

(/X indicates an active LOW function)

LANCAM Interface:

DQ15–DQ0 (Data Bus, Input/Output, TTL)

The DQ15–DQ0 lines transfer data, commands and status between the MU9C8148 and the LANCAM. The direction and nature of the information that flows between the devices is determined by the states of /CM and /W.

/E (Chip Enable, Output, Three-state TTL)

The /E output enables the LANCAM while LOW and registers /W, /CM, /EC and DQ15–DQ0 (if /W is LOW) on the falling edge of /E. If /W is HIGH, data on DQ15–DQ0 from the LANCAM is valid on the rising edge of /E.

/W (Write Enable, Output, Three-state TTL)

The /W output selects the direction of data flow during a LANCAM cycle. DQ15–DQ0 write to the LANCAM if /W is LOW at the falling edge of /E. Read data is output from the LANCAM to DQ15–DQ0 on the rising edge of /E if /W is HIGH at the falling edge of /E.

/CM (Data/Command Select, Output, Three-state TTL)

The /CM signal determines whether DQ15–DQ0 contain LANCAM data or commands. /CM is LOW at the falling edge of /E for Command cycles and HIGH for Data cycles.

/EC (Enable Comparison, Output, Three-state TTL)

The /EC signal enables the LANCAM /MF pin to output the results of a comparison. If /EC is LOW at the falling edge of /E for a given cycle, the LANCAM /MF output is enabled on the rising edge of /E. If /EC is HIGH, the LANCAM /MF output is held HIGH.

/MI (Match Flag, Input, TTL)

The LANCAM /MF pin takes the MU9C8148's /MI input LOW if a valid match occurs during a Comparison cycle, and /EC was also LOW at the start of that cycle. The state of the /MI pin controls branching in the MU9C8148's routines.

/FI (Full Flag, Input, TTL)

The /FI input will be driven LOW by the LANCAM /FF output pin if all the LANCAM memory locations have valid contents. The status of the /FI pin can be read by the Host processor from the MU9C8148's Control register.

Transceiver Interface:

RXD (Receive Data, Input, TTL)

The RXD pin monitors the data received by the TMS38053/4 from the Token Ring. RXD is clocked on the rising edge of /RXC.

MU9C8148

PIN DESCRIPTIONS (CONT'D)

RXC (Receive Clock, Input, TTL)

The rising edge of RXC clocks the RXD data received by the TMS38053/4 from the Token Ring. The RXC clock is also used to generate the control signals to the LANCAM, and controls the internal operation of the MU9C8148.

/RDY (Ring Interface Ready, Input, TTL)

The /RDY pin is taken LOW by the TMS38053/4 to indicate the presence of received data. /RDY must be HIGH if the RXD data is not valid.

MAC Interface:

XMATCH (Match, Output, Three-state TTL)

XMATCH goes HIGH in combination with XFAIL going LOW to indicate that the frame currently being received should be copied. If XFAIL is HIGH, XMATCH is forced LOW.

XFAIL, /FLUSH (FAIL/FLUSH, Output, Three-state TTL)

The function of this pin is defined by the Control register. If the MU9C8148 is connected to a TMS380CX6, this pin is defined as XFAIL, which goes HIGH when XMATCH goes LOW, to tell the TMS380CX6 to discard the frame and flush the receive buffer.

Host Processor Interface:

ALE, SRNW (Address Latch Enable/System Read Not Write, Input, TTL)

This pin is ALE when the MU9C8148 is used in the Intel mode. The falling edge of ALE latches the address on the address lines. If the MU9C8148 is in the Motorola mode, this pin becomes SRNW, and is HIGH for a Host Processor Read cycle and LOW for a Write cycle.

/CS (Chip Select, Input, TTL)

/CS going LOW enables the Host Processor interface of the MU9C8148 for a Host Processor read or write. When /CS is HIGH, /HBRDY goes three-state and the Host Processor interface is disabled.

A4-A0 (Address, Input, TTL)

The Address pins select the internal register for Host processor reads and writes. In the Intel mode, the Address pins are latched by the falling edge of ALE. In the Motorola mode, the Address pins must remain stable until the rising edge of /LD and /UDS, as shown in the Timing diagrams.

D15-D0 (Data, Common I/O, TTL)

The Data pins transfer data between the Host Processor and the internal registers of the MU9C8148. The data pins are registered on the falling edge of /HBRDY in the Write mode, and are valid on the falling edge of /HBRDY in the Read mode, as shown in the Timing diagrams.

/RS, /LDS (Read Strobe/Lower Data Strobe, Input, TTL)

In the Intel mode, this pin is /RS and is taken LOW to begin a read cycle to the Host Processor interface. Data on D(15-0) is valid when /HBRDY goes LOW. In the Motorola mode, this pin is /LDS for Host processor read and write cycles. The falling edge of /LDS or /UDS begins the cycle; data is strobed when /HBRDY goes LOW for a Write cycle, and is valid on D(15-0) when /HBRDY goes LOW for a Read cycle.

/WS, /UDS (Write Strobe/Upper Data Strobe, Input, TTL)

In the Intel mode, this pin is /WS, and is taken LOW to begin a write cycle from the Host Processor interface. Data on D(15-0) is strobed into the MU9C8148 when /HBRDY goes LOW. In the Motorola mode, this pin is /UDS for Host processor read and write cycles. The falling edge of /LDS or /UDS begins the Write cycle; data is strobed when /HBRDY goes LOW for a Write cycle, and is valid on D(15-0) when /HBRDY goes LOW for a Read cycle.

/HBRDY (Ready, Output, Three-state TTL)

/HBRDY goes LOW to indicate to the Host processor that a data transfer is completed for a Write cycle or that data is valid for a Read cycle. After the Host processor takes /RS, /WS, or /LDS and /UDS HIGH, the MU9C8148 takes /HBRDY HIGH. /HBRDY becomes three-state one RXC period after it goes HIGH, or when /CS goes HIGH.

/HBEN (Data Buffer Enable, Output, TTL)

/HBEN goes LOW to enable external bi-directional buffers, if are needed on the D15-D0 lines. /HBEN goes HIGH to disable the external buffers.

/HBDIR (Data Buffer Direction, Output, TTL)

/HBDIR controls the direction of data flow in external bi-directional buffers. /HBDIR goes LOW to enable data flowing to the MU9C8148 and HIGH to enable data coming from the MU9C8148 registers.

/INT (Interrupt, Output, Open Drain)

This pin goes LOW to notify the Host processor that the MU9C8148 is running an Instruction Buffer routine, therefore accessing the LANCAM. /INT will remain LOW as long the routine is running.

MU9C8148

PIN DESCRIPTIONS (CONT'D)

Arbitration Signals between two MU9C8148s:

/RQ (Request, Output, TTL)

The /RQ pin is used to arbitrate access to a shared LANCAM, and goes LOW when access is required to the LANCAM. /RQ of one MU9C8148 is connected to /RQI on the other MU9C8148 to provide notification that a LANCAM access is pending. One MU9C8148 is configured as Master, and the other as Slave, to resolve conflicts. /RQ goes HIGH after the LANCAM interface transactions are completed.

/RQI (Request Indication, Input, TTL)

If /RQI goes LOW, another MU9C8148 has a request pending for access to the LANCAM. The LANCAM interface on this chip is then disabled, and execution of routines is postponed until /RQI goes HIGH. This pin must be tied HIGH if it is not used.

Miscellaneous:

/RESET (Hardware Reset, Input, TTL)

Taking /RESET LOW for at least 2 RxC cycles sets the MU9C8148 to a predefined state. The contents of all registers

are 0000H after a Hardware reset (except for register 04H), all three-state pins are High-Z, and all TTL output pins will be HIGH.

/FULL, /EMPTY (Full/Empty, Output, Open Drain)

If part of the Instruction buffer in the MU9C8148 is configured as a FIFO, this active-LOW pin can be configured to signal whether the FIFO is full (all entries contain valid data) or empty (no entry contains data). The definition of this signal is programmed in the FIFO Control register.

/INTEL (HPI Selection, Input, TTL)

The /INTEL pin identifies which type of microcontroller is connected to the Host Processor interface. This pin is set LOW for Intel-type addressing modes and HIGH for Motorola-type addressing modes.

VCC, GND (Positive Power Supply and Ground)

These pins are the main power supply connections to the MU9C8148. VCC must be held at $+5V \pm 10\%$ relative to the GND pin, which is at 0V (system reference potential), for correct operation of the device.

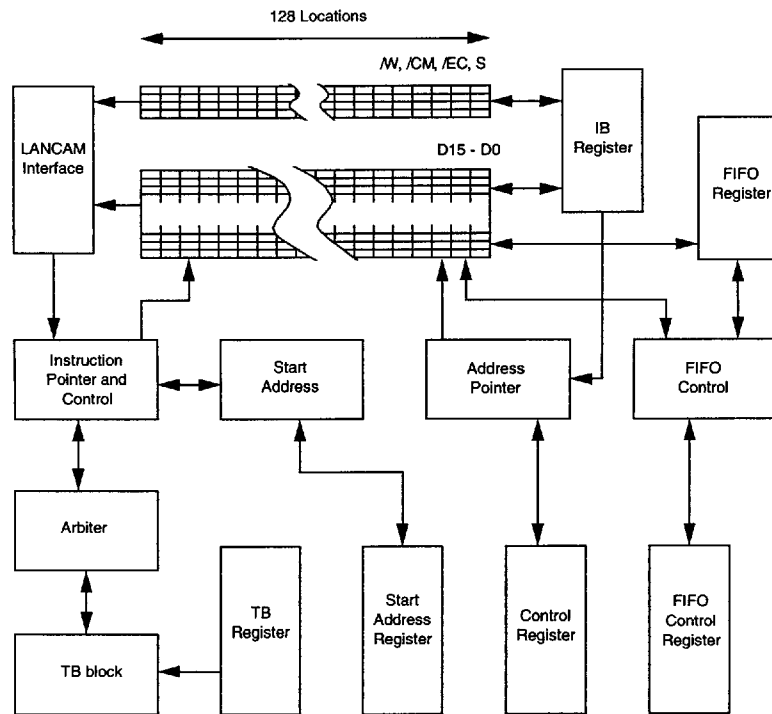

Figure 1: The Instruction Buffer

FUNCTIONAL DESCRIPTION

Referring to the Block diagram shown on Page 1, the MU9C8148 consists of four functional blocks: the Transparent Bridging (TB) block, the Source Routing Block (SRB), the Instruction Buffer (IB), and the Arbiter. Four interfaces connect the MU9C8148 to the Transceiver, the MAC controller, the Host processor, and the LANCAM. For a detailed description of Token Ring frames, refer to IEEE Standard 802.5, or the IBM Token-Ring Network Architecture Reference.

Transparent Bridging Block

If a frame does not contain an RIF, the TB block makes decisions whether to copy or discard a frame based on the Destination address (DA). If the bridge is set for Transparent bridging only (the TBO bit in the Control register is HIGH, disabling the SRB), the TB block also makes copy or discard decisions for frames which do contain an RIF. The TB block parses the data as received from the Transceiver off the Token Ring network, and indicates to the MAC whether to assert the XMATCH and/or XFAIL (/FLUSH) signals. For each frame, the TB block examines the Token bit, the Frame Type bits, the Destination address (DA), and the Source address (SA), which contains the Routing Information indicator (RII).

The Token bit signals whether the current frame is a Token or a regular frame. If the Token bit is LOW, a Token frame is being received, and the TB block discards the frame. For a regular frame, the Frame Type bits signify the type of frame (LLC, MAC, or Reserved) being received, and the TB block decides to copy or discard the frame, based on the settings in the Frame Type Selection register and the results of filtering on the Destination address (DA).

Positive or negative filtering on the DA can be done for frames without an RIF, or for all frames when the bridge is set for Transparent bridging only, based on the setting of the PONNE bit in the Transparent Bridging register. Positive filtering implies that a frame should be forwarded if its DA is found in the LANCAM address database. Routine 0 in the instruction buffer examines the DA field to determine whether a frame should be copied or not. The results of this comparison are used to notify the LAN controller to copy or discard the frame. Negative filtering implies that a frame should be forwarded if its DA is not found in the address database. In this case, the MU9C8148 checks the DA before routine 0 is started to differentiate between MAC, Broadcast, Functional and Group addresses. Based upon the settings of the Transparent Bridging register, the TB block discards a frame whose DA is a Broadcast, Functional and/or Group address before Routine 0 is started.

If the MU9C8148 is not used in a Transparent Bridging Only mode and a frame containing an RIF is received, Routine 2 in the Instruction buffer can be started. The results of this comparison are combined with the output of the SRB to instruct the LAN controller to copy or discard the frame. Routine 2 can only perform positive filtering.

The Source address (SA) of a frame can be used to update the database of addresses stored in the LANCAM. Routine 1 in the Instruction buffer checks the SA of a frame against all the entries in the database, and if the SA is not found, the address is new, and if the frame received is error free, the address can be learned by adding it to the LANCAM database. Learning can

be enabled on the four different frame types (MAC, LLC and two types of reserved frames) individually. For each frame type, a choice between two different learning routines can be made in the Transparent Bridging register. Note that learning can only take place when the RII bit of the frame is ZERO, or for every frame when the TBO bit is HIGH. Thus, Routine 0 or Routine 2 is started after the RII bit is received and evaluated. Routine 1 is started by the TB block after the Frame Status field has been received and the frame found to be error-free.

Source Routing Block

The Source Routing Block (SRB) only decides to copy or discard a frame if it contains an RIF, and the MU9C8148 is not in TBO mode. The SRB (in combination with the results of Routine 2 of the TB) notifies the MAC interface how to assert its output flags.

When a frame is received, the SRB checks whether the Token bit in the AC field is LOW, in which case a Token frame is being received and no further processing is necessary. If the Token bit is HIGH, a regular frame is being received and the SRB examines the Frame Type bits in the FC field, which give the type of frame being received. The frame types to be processed by the SRB (those with an RIF) are selectable in the Frame Type Selection register. If the RII bit is HIGH, the SRB signals the MAC interface, based on the frame type and the settings in the Frame Type Selection register, either to discard the frame and flush the buffer, or to continue to check the RIF of the frame, or to accept the frame. If the RII is LOW, the SRB is not allowed to process the frame any further and waits for the next frame to arrive.

If a copy/discard decision is to be made based on the RIF, the SRB examines the information contained in the RCF. If the length (LTH) bits of the RCF indicate a length equal to zero, or contain an odd length, or if the length of the RIF is longer than the allowed length stored in the RIF Length register, reception of the frame is stopped, and the SRB indicates that the frame is to be discarded. The D bit of the Routing Control Field (RCF) indicates which direction the Routing Descriptors (RDs) of the RIF should be interpreted.

The SRB provides for seven Ring(in)-Bridge-Ring(out) combinations (LIN-BN-LOUT) stored in the Source Ring Number register and Bridge/Destination Ring Number registers. LIN is the LAN ID of the ring connected to that specific port, while the BN(s) and LOUT(s) depend on the topology of the network and the bridge design. The SRB provides for checks between the LAN ring numbers and bridge numbers contained in every RD with every LIN-BN-LOUT stored, allowing the user to develop an SR(T) bridge with an internal virtual ring, or a bridge with a Full Mesh design (IEEE P802.5M).

If the Routing Type (RT) bits are equal to 0XXB, a Specifically-Routed Frame (SRF) is being received, and should be forwarded on the conditions shown in Table 1. If the RT bits are equal to 10XB, the frame is an All Routes Explorer (ARE) frame, and should be handled as shown in Table 1. If the RT bits are equal to 11XB, the frame is a Spanning Tree Explorer (STE) frame, and should be dealt with as shown in Table 1. Also described in Table 1 are the conditions on which the Error counters (Register 17H) are incremented.

MU9C8148

FUNCTIONAL DESCRIPTION (CONT'D)		
Type	Condition	Action
Specifically Routed Frame	A prestored LIN-BN-LOUT combination is found in the RIF & that LOUT has occurred only once in the RIF.	Copy frame. Signal MAC Interface.
	A prestored LIN-BN-LOUT combination is found in the RIF & that LOUT has occurred more than one time in the RIF.	Discard frame. Signal MAC Interface. Increment DUPLOUT counter.
	No prestored LIN-BN-LOUT combination is found in the RIF.	Discard frame. Signal MAC Interface.
	#RDS \geq SRRFRD	Discard frame. Signal MAC Interface.
	Prestored LIN is found more than once in the RIF.	Discard frame. Signal MAC interface.
All Routes Explorer Frame	LTH = 2	Copy frame. Signal MAC Interface.
	Last LOUT in RIF \neq LIN, LTH \neq 2	Discard frame. Signal MAC Interface. Increment LANIDMISMATCH counter.
	#RDS \geq ARERD	Discard frame. Signal MAC Interface. Increment ARERDLIMITEXCEEDED counter.
	Not all prestored LOUTs in RIF #RDS < ARERD	Copy frame. Signal MAC Interface.
	All prestored LOUTs in RIF, LTH \neq 2	Discard frame. Signal MAC Interface.
Spanning Tree Explorer Frames	LTH = 2	Copy frame. Signal MAC Interface.
	Last LOUT in RIF \neq LIN, LTH \neq 2	Discard frame. Signal MAC Interface. Increment LANIDMISMATCH counter.
	#RDS \geq STERD	Discard frame. Signal MAC Interface. Increment STERDLIMITEXCEEDED counter.
	Not all prestored LOUTs in RIF #RDS < STERD	Copy frame. Signal MAC Interface.
	All prestored LOUTs in RIF, LTH \neq 2	Discard frame. Signal MAC Interface. Increment DUPLANIDORTREEERROR counter.
	Bit DISSTE = ONE	Discard frame. Signal MAC Interface.
<p>Note: Signalling takes place at the end of the RIF. Discard actions overrule copy actions. The result of the SRB is OR'ed with the result of Routine 2, whereby the copy action overrules.</p> <p>Table 1: Source Routing Forwarding Conditions</p>		

Rev. 5.5 Draft web

FUNCTIONAL DESCRIPTION (CONT'D)

Instruction Buffer

The Instruction buffer (IB) shown in Figure 1 consists of the following: the 128-entry Instruction storage, the Instruction pointer (IP), the Address pointer, the Start address registers, the FIFO, and FIFO control registers.

The Instruction Storage (IS) can store up to seven down-loaded routines which contain instructions for the LANCAM to execute, plus room for data storage. The IS location accessed by the Host processor port is controlled by an auto-incrementing Address pointer, which is part of the Control register. Each instruction is a 16-bit LANCAM op-code or data word along with 3 bits that indicate the level of /W, /CM, /EC during the instruction. An additional S-bit is used to indicate whether this entry is a LANCAM instruction or a MU9C8148 instruction.

The Instruction pointer (IP) points to the instruction currently executing. At the start of a routine the IP is loaded with the appropriate Start address. The IP can also be loaded from Branch Routine addresses or addresses contained in an instruction itself. For example, when a "Wait for a match" instruction is executed and no match has occurred, the IP is loaded with the address of the next instruction to execute.

The Start Address registers contain the start addresses of all seven routines. When a routine is started, this address is copied into the IP and execution is started. In addition to the regular start addresses, two Branch Routine addresses are available in the IB Start I register and are selected based on the received frame type, as enabled in the Transparent Bridging register. If a "Wait for match then execute at Branch Routine address selected" instruction is executed and no match occurs, the IP is loaded with the Branch Routine address selected by the current frame type and execution continues.

Part of the IS may be used as a FIFO for data storage. Data from the routines can be moved either to or from the Host Processor interface through the FIFO. While routines are loaded into the IS from 00H up towards 7FH, the FIFO goes from 7FH down to the limit set in the FIFO control register. The functionality of the /FULL or /EMPTY flag is programmed in the FIFO Control register to prevent FIFO overflow or underflow situations.

Programming and Execution of Routines

The IS is loaded and read through the IB register in two 16-bit cycles. The first 16-bit cycle moves the data on the D15-D0 lines of the Host Processor interface into the data field of the location in the IB indicated by the Address pointer in the Control register, or vice-versa in case of a read from the IB register. The second 16-bit word is written to or read from the /W, /CM, /EC, and /S bits of that same location.

The Control register contains an Address pointer that selects the accessed location in the IS. The Address pointer can be read out or overwritten. It is incremented when the Host processor has completed the two write or read cycles to one location of the IB.

Routines in the instruction buffer can be started either by the Host processor (Routines 3-6 only) or the Transparent Bridging block. If a routine is started by the Host processor, it can be

either started directly, or after an RII has been received, or after the second C bit of the Frame Status field has been received. If the STDIR bit of a specific routine is set HIGH, the routine is started immediately. If the START bit of a specific routine is set to HIGH, the routine is started directly after an RII has been received (SA/DA is HIGH) or after the second C bit has been received (SA/DA is LOW). After execution has finished, the START and STDIR bits are set LOW. If the AUTOSTART bit for Routines 3, 4, 5 or 6 is set HIGH in the IB Start II register, that routine is started for every frame received directly after an RII has been received (when SA/DA is HIGH), or after the second C bit has been received (when SA/DA is LOW). If more than one routine should be started at the same time, the routine with the numerically lowest start address is started first.

The TB block starts Routine 0, 1 or 2 when the enable bit of that routine is set HIGH. Routines 0 and 2, used for DA comparison, are started directly after the RII while Routine 1, used for SA comparison, is started after the last C bit of the FS field has been received, and if the frame was error-free.

Arbiter

The Arbiter block has two primary tasks: 1) Arbitration between the execution of different routines stored in the Instruction Buffer; and, 2) Arbitration between two MU9C8148's when they are sharing the same LANCAM.

Routine Priorities

Of the seven routines stored in the Instruction buffer, execution of Routines 0-2 is time critical because there is a direct relation to the incoming data stream of the Token Ring; therefore, they have the highest priority and cannot be interrupted by other routines. The time length of Routines 0 or 2 plus Routine 1 must fit in the time interval of a minimum length frame. Routines 3-6 have a lower priority and they can be interrupted by routines having a lower number.

During execution of Routine 0-2, no lower priority routine can be started. When a second routine is programmed to be started and execution of the first routine has ended, this second routine is started immediately afterward. A currently running routine can be interrupted by a higher priority routine, and the lower priority routine will re-start from the beginning immediately after the interrupting routine is finished.

Host Processor Access

The Address bus, A(4-0), is used to select the Registers, Instruction Buffer, or LANCAM for access from the Host processor port. Direct access to the LANCAM through registers 18H to 1FH should only be used for LANCAM initialization and should be completed prior to enabling IB routines. After that, new addresses written to the LANCAM by the host processor should be first stored in the IB, and a routine started that transfers it to the LANCAM. Access to the IB is arbitrated if network activity triggers a pre-stored routine. The /INT pin goes LOW (the INT bit in the Control register goes HIGH) to notify the host processor that a routine is running. (If an access to the IB is attempted while /INT is LOW, the return of /HBRDY is delayed slightly until the routine instruction currently executing is completed.) /INT will stay LOW until all routines have completed. The processor can then re-issue its request.

MU9C8148

FUNCTIONAL DESCRIPTION (CONT'D)

For a non-arbitrated Write cycle, /HBEN and /HBDIR go LOW after the second rising edge of RXC past the falling edge of /WS (Intel mode) or /UDS and /LDS (Motorola mode). /HBRDY goes LOW after the second rising edge of RXC past the falling edge of /HBEN for Register and Instruction Buffer write cycles, and after the 8th rising edge of RXC past the falling edge of /HBEN for CAM write cycles. The write data on the D(15-0) bus is strobed by the rising edge of RXC that outputs /HBRDY.

For a non-arbitrated Read cycle, /HBEN goes LOW after the third rising edge of RXC past the falling edge of /RS (Intel mode) or /UDS and /LDS (Motorola mode). /HBRDY goes LOW after the first rising edge of RXC past the falling edge of /HBEN for a Register read cycle, the 4th rising edge of RXC past the falling edge of /HBEN for an Instruction Buffer read cycle, and the 7th rising edge of RXC past the falling edge of /HBEN for a CAM read cycle. Read data is output to the D(15-0) bus immediately prior to /HBRDY going LOW.

For both non-arbitrated Write and Read cycles, /HBRDY goes HIGH after the first rising edge of RXC past the rising edge of /WS or /RS in Intel mode or /UDS, /LDS in Motorola mode. /HBEN and /HBDIR return HIGH and /HBRDY will go three-state after the next rising edge of RXC.

On a FIFO write, /HBRDY goes LOW after the fifth rising edge of RXC past the falling edge of /HBEN. On a FIFO read, /HBRDY goes LOW after the fourth rising edge of RXC past the falling edge of /HBEN.

MAC Interface

The TB block and/or the SRB notify the MAC interface to copy or reject a frame through the XMATCH and the XFAIL pins for the TMS380CX6, or the /FLUSH pin for the 82C581, using the TEXAS bit in the Control register to select the operating mode. When Routine 2 is enabled, the results from the TB and the SRB are combined.

Transceiver Interface

The MU9C8148 connects to the received data bus between the TMS38053/4 and the TMS380CX6. The differential Manchester

encoded data received from the Token Ring transceiver is input to the RXD pin which clocked by the RXC clock. The /RDY signal indicates the presence of received data on the RXD pin. The Transceiver interface notifies the TB block and the SRB that it has detected a JK Start delimiter in the incoming data stream and to begin parsing the other fields of the frame. The Transceiver interface performs a number of error checks: whether the data contained any control characters before an ED was received; that no second SD is received before an ED is received; and, /RDY is still asserted. In any of these cases, both the TB and SRB are notified and reception of data is cancelled. Also checked are: the correctness of the FCS, the value of the E bit in the ED, and the values of both C bits and both A bits in the FS field. If there is an error situation detected in one of these items, the TB is notified not to start Routine 1.

Host Processor Interface

The Host Processor interface is configured for Intel or Motorola addressing modes using the /INTEL pin. In both modes the MU9C8148 is a slave on the processor bus and can be programmed using the registers described in this document. The MU9C8148 provides /HBEN and /HBDIR to enable the user to add external bi-directional buffers in the D15-D0 datalines. In Intel mode, ALE is used to latch the address lines. In Motorola mode, both /UDS and /LDS are used to load the upper and lower bytes to all of the registers including the Instruction buffer and FIFO.

Two MU9C8148s Sharing One LANCAM

Two MU9C8148s may share the same LANCAM string if they are operating at the same frequency, using /RQ and /RQI to arbitrate the LANCAM access by setting the ASSRQ bit in the Control register to HIGH. One MU9C8148 is set to be Master, and given Routines 0-2, and the other is set to be Slave and given the non-time-critical Routines 3-6 in addition to Routines 0-2. Routines 3-6 running on the Slave can be interrupted immediately by time-critical routines running on either the Master or Slave, but if both MU9C8148s try to run a high priority routine at the same time, the Master device will be given priority, and the Slave device will start its routine after the Master has finished.

INSTRUCTION SET DESCRIPTION

Instruction: LANCAM Instruction
Binary Op Code: `iiii iiiii iiiii wce0`
i Instruction Code (see The LANCAM Handbook)
w The state of /W
c The state of /CM
e The state of /EC

This instruction transfers data or commands to or from the LANCAM. Instructions from the LANCAM instruction set are described in the LANCAM Handbook. The state of the control outputs /W, /CM and /EC at the falling edge of /E for this cycle are defined by w,c, and e.

Instruction: Stop Execution
Binary Op Code: `0000 0000 0000 0000 xxx1`
x Don't Care

The "Stop Execution" instruction stops the execution of the routine currently running. Control is transferred to the arbiter.

Instruction: Wait for match for `yyyyB + 4` cycles, if no match then execute at Branch Routine Address selected.
Binary Op Code: `0001 yyyy rrr rrr xxx1`
y Wait period
r Reserved (set LOW)
x Don't Care

This instruction waits for a maximum period of `yyyyB + 4` clock cycles for the /MI input to become active, asserting XMATCH and XFAIL as appropriate. If no match condition occurs during that period, a branch is executed to the address stored in the Branch Routine address determined by the frame type. If a match condition is detected, execution proceeds to the instruction at the next address.

INSTRUCTION SET DESCRIPTION (CONT'D)

Instruction: Wait for match for yyyyB + 4 cycles, if no match then execute at address aaaaaaaB.

Binary Op Code: 0010 yyyy raaa aaaa xxx1

y Wait period
r Reserved (set LOW)
a Address
x Don't Care

This instruction waits for a maximum period of yyyyB + 4 clock cycles for the /MI input to become active, asserting XMATCH and XFAIL as appropriate. If no match condition occurs during that period, a branch is executed to the address which is stored in the "a" bits of the instruction. If a match condition is detected, execution proceeds to the instruction in the next address.

Instruction: Move DA part 0 to DQ15-DQ0.

Binary Op Code: 0011 0000 0000 0000 0ce1

c The state of /CM
e The state of /EC

The "Move DA part 0 to DQ15-DQ0" instruction places the least significant part of the DA address (bits 15-0) on the DQ15-DQ0 lines. The control outputs /CM and /EC at the falling edge of /E for this cycle are defined by c and e.

Instruction: Move DA part 1 to DQ15-DQ0.

Binary Op Code: 0011 0000 0000 0001 0ce1

c The state of /CM
e The state of /EC

The "Move DA part 1 to DQ15-DQ0" instruction places DA address bits 31-16 on the DQ15-DQ0 lines. The control outputs /CM and /EC at the falling edge of /E for this cycle are defined by c and e.

Instruction: Move DA part 2 to DQ15-DQ0.

Binary Op Code: 0011 0000 0000 0010 0ce1

c The state of /CM
e The state of /EC

This instruction places the most significant part of the DA address (bits 47-32) on the DQ15-DQ0 lines. The control outputs /CM and /EC at the falling edge of /E for this cycle are defined by c and e.

Instruction: Move SA part 0 to DQ15-DQ0.

Binary Op Code: 0011 0000 0000 0011 0ce1

c The state of /CM
e The state of /EC

The "Move SA part 0 to DQ15-DQ0" instruction places the least significant part of the SA address (bits 15-0) on the DQ15-DQ0 lines. The control outputs /CM and /EC at the falling edge of /E for this cycle are defined by c and e.

Instruction: Move SA part 1 to DQ15-DQ0.

Binary Op Code: 0011 0000 0000 0100 0ce1

c The state of /CM
e The state of /EC

The "Move SA part 1 to DQ15-DQ0" instruction places SA address bits 31-16 on the DQ15-DQ0 lines. The control

outputs /CM and /EC at the falling edge of /E for this cycle are defined by c and e.

Instruction: Move SA part 2 to DQ15-DQ0.

Binary Op Code: 0011 0000 0000 0101 0ce1

c The state of /CM
e The state of /EC

This instruction places the most significant part of the SA address (bits 47-32) on the DQ15-DQ0 lines. The control outputs /CM and /EC at the falling edge of /E for this cycle are defined by c and e.

Instruction: Move data from address aaaaaaaB to DQ15-DQ0.

Binary Op Code: 0100 rrrr raaa aaaa 0ce1

r Reserved
a Address
c The state of /CM
e The state of /EC

The "Move data from address aaaaaaaB to DQ15-DQ0" instruction places the contents of the address specified by the "a" bits on the DQ15-DQ0 lines. The control outputs /CM and /EC at the falling edge of /E for this cycle are defined by c and e.

Instruction: Move data from DQ15-DQ0 to address aaaaaaaB.

Binary Op Code: 0101 rrrr raaa aaaa 1ce1

r Reserved
a Address
c The state of /CM
e The state of /EC

This instruction places the values on the DQ15-DQ0 lines in the address specified by the "a" bits. The control outputs /CM and /EC at the falling edge of /E for this cycle are defined by c and e.

Instruction: Move data from the FIFO to DQ15-DQ0.

Binary Op Code: 0110 rrrr rrrr rrrr 0ce1

r Reserved
c The state of /CM
e The state of /EC

The "Move data from the FIFO to DQ15-DQ0" instruction places the contents of the next FIFO location on the DQ15-DQ0 lines. The control outputs /CM and /EC at the falling edge of /E for this cycle are defined by c and e.

Instruction: Move data from DQ15-DQ0 to the FIFO.

Binary Op Code: 0111 rrrr rrrr rrrr 1ce1

r Reserved
c The state of /CM
e The state of /EC

This instruction places the values on the DQ15-DQ0 lines into the FIFO. The control outputs /CM and /EC at the falling edge of /E for this cycle are defined by c and e.

MU9C8148

REGISTER SET DESCRIPTION

BIT	NAME	DESCRIPTION
00H: Control Register		
15	RESET	If RESET is HIGH, a reset of the MU9C8148 takes place.
14	TEXAS	If TEXAS is HIGH, the MU9C8148 is programmed for the Texas Instruments TMS380CX6 MAC controller.
13	ASSRQ	If ASSRQ is HIGH, the /RQ and /RQI mechanism become active, to permit sharing a LANCAM with another MU9C8148. If this bit is LOW, both lines are inactive, so no arbitration takes place.
12	M/S	If M/S is HIGH, this MU9C8148 is a Master while sharing a LANCAM with another MU9C8148. If this bit is ZERO, this MU9C8148 is a Slave. If bit ASSRQ is LOW, the M/S bit is "don't care".
11	TBO	If TBO is HIGH, all incoming frames are filtered by the Transparent Bridging block only. No SR bridging takes place.
10	DISSTE	If DISSTE is HIGH, all Spanning Tree Explorer frames are discarded. The MU9C8148 signals the MAC to flush these frames. If DISSTE is LOW, STE frames are accepted per the programmed filtering criteria.
9	FF	FF indicates the level of the /FI input.
8	RDFCP	If RDFCP is HIGH, access to the Error Counter 17H is reset to point to DUPL7-0 and IR17-0.
7	INT	INT indicates the inverse of the level of the /INT output.
6-0	APR6-0	APR6-0 point to the location in the IB which can be accessed through the IB Register.
01H: Frame Type Selection Register		
15	MSRENBL	If MSRENBL is LOW, every MAC frame containing an RIF is discarded. The MAC is signalled to flush the frame. If MSRENBL is HIGH, the MSRFILT bit determines if the frame is filtered or copied directly. MSRENBL is "don't care" if TBO is HIGH.
14	MSRFILT	If MSRFILT is LOW, the MU9C8148 signals the MAC chip to copy every MAC frame containing an RIF. If MSRFILT is HIGH, the MU9C8148 checks the RIF and forwards the frame if the programmed forwarding conditions are met. MSRFILT is "don't care" if TBO is HIGH.
13	LSRENBL	If LSRENBL is LOW, every LLC frame containing an RIF is discarded. The MAC is signalled to flush the frame. If LSRENBL is HIGH, the LSRFILT bit determines if the frame is filtered or copied directly. LSRENBL is "don't care" if TBO is HIGH.
12	LSRFILT	If LSRFILT is LOW, the MU9C8148 signals the MAC to copy every LLC frame containing an RIF. If LSRFILT is HIGH, the MU9C8148 checks the RIF and forwards the frame if the programmed forwarding conditions are met. LSRFILT is "don't care" if TBO is HIGH.
11	1SRENBL	If 1SRENBL is LOW, every reserved type 1 frame containing an RIF is discarded. The MAC is signalled to flush the frame. If 1SRENBL is HIGH, the 1SRFILT bit determines if the frame is filtered or copied directly. This bit is "don't care" if TBO is HIGH.
10	1SRFILT	If 1SRFILT is LOW, the MU9C8148 signals the MAC chip to copy every reserved type 1 frame containing an RIF. If 1SRFILT is HIGH, the MU9C8148 checks the RIF and forwards the frame if the programmed forwarding conditions are met. This bit is "don't care" if TBO is HIGH.
9	2SRENBL	If 2SRENBL is LOW, every reserved type 2 frame containing an RIF is discarded. The MAC is signalled to flush the frame. If 2SRENBL is HIGH, the 2SRFILT bit determines if the frame is filtered or copied directly. This bit is "don't care" if TBO is HIGH.
8	2SRFILT	If 2SRFILT is LOW, the MU9C8148 signals the MAC to copy every reserved type 2 frame containing an RIF. If 2SRFILT is HIGH, the MU9C8148 checks the RIF and forwards the frame if the programmed forwarding conditions are met. This bit is "don't care" if TBO is HIGH.
7	MTRENBL	If MTRENBL is LOW, every MAC frame not containing an RIF is discarded. The MAC chip is signalled to flush the frame. If MTRENBL is HIGH, the MTRFILT bit determines if the frame is filtered or copied directly. If TBO is HIGH, filtering is also done on MAC frames containing an RIF.
6	MTRFILT	If MTRFILT is LOW, the MU9C8148 signals the MAC to copy every MAC frame not containing an RIF. If MTRFILT is HIGH, the MU9C8148 checks the DA and forwards the frame if the forwarding conditions are met, whether or not the frame contains an RIF.
5	LTRENBL	If LTRENBL is LOW, every LLC frame not containing an RIF is discarded. The MAC chip is signalled to flush the frame. If LTRENBL is HIGH, the LTRFILT bit determines if the frame is filtered or copied directly. If TBO is HIGH, filtering is also done on LLC frames containing an RIF.
4	LTRFILT	If LTRFILT is LOW, the MU9C8148 signals the MAC to copy every LLC frame not containing an RIF. If LTRFILT is HIGH, the MU9C8148 checks the DA and forwards the frame if the forwarding conditions are met, whether or not the frame contains an RIF.
3	1TRENBL	If 1TRENBL is LOW, every reserved type 1 frame not containing an RIF is discarded. The MAC is signalled to flush the frame. If 1TRENBL is HIGH, the 1TRFILT bit determines if the frame is filtered or copied directly. If TBO is HIGH, filtering is also done on reserved type 1 frames with an RIF.
2	1TRFILT	If 1TRFILT is LOW, the MU9C8148 signals the MAC to copy every reserved type 1 frame not containing an RIF. If 1TRFILT is HIGH the MU9C8148 checks the DA and forwards the frame if the forwarding conditions are met, whether or not the frame contains an RIF.

REGISTER SET DESCRIPTION (CONT'D)

BIT	NAME	DESCRIPTION
1	2TRENBL	If 2TRENBL is LOW, every reserved type 2 frame not containing an RIF is discarded. The MAC is signalled to flush the frame. If 2TRENBL is HIGH, the 2TRFILT bit determines if the frame is filtered or copied directly. If TBO is HIGH, filtering is also done on reserved type 2 frames with an RIF.
0	2TRFILT	If 2TRFILT is LOW, the MU9C8148 signals the MAC chip to copy every reserved type 2 frame not containing an RIF. If 2TRFILT is HIGH, the MU9C8148 checks the DA and forwards the frame if the forwarding conditions are met, whether or not the frame contains an RIF.
02H: Transparent Bridging Register		
15	PONNE	If PONNE is LOW, the MU9C8148 performs negative filtering (Routine 0) for frames without an RIF, or for all frames when TBO is HIGH. If PONNE is HIGH positive filtering is performed.
14	DISGA	If DISGA is HIGH, all frames with a DA containing a group address and not containing an RIF (or all frames with a DA containing a group address when TBO = HIGH) are discarded if PONNE is LOW. If PONNE is HIGH, this bit becomes "don't care".
13	DISBA	If DISBA is HIGH, all frames with a DA containing a broadcast address and not containing an RIF (or all frames with a DA containing a broadcast address when TBO = HIGH) are discarded when PONNE is also programmed LOW. If PONNE is set HIGH, this bit becomes "don't care".
12	DISFA	If DISFA is HIGH, all frames with a DA containing a functional address and not containing an RIF (or all frames with a DA containing a functional address when TBO = HIGH) are discarded when PONNE is made LOW. If PONNE is HIGH, this bit becomes "don't care".
11	MLRN	If MLRN is LOW, no learning of addresses from MAC frames takes place. If this bit is set HIGH, learning of addresses from MAC frames take place by starting Routine 1 (if starting is enabled), when the frame doesn't contain an RIF (or for all MAC frames when TBO = HIGH).
10	LLRN	If LLRN is LOW, no learning of addresses from LLC frames takes place. If this bit is set HIGH, learning of addresses from LLC frames take place by starting Routine 1 (if starting is enabled), when the frame doesn't contain an RIF (or for all LLC frames when TBO = HIGH).
9	1LRN	If 1LRN is LOW, no learning of addresses from reserved type 1 frames takes place. If this bit is HIGH, learning of addresses from reserved type 1 frames take place by starting Routine 1 (if starting is enabled), when the frame doesn't contain an RIF (or for all reserved type 1 frames when TBO = HIGH).
8	2LRN	If 2LRN is LOW, no learning of addresses from reserved type 2 frames takes place. If 2LRN is set HIGH, learning of addresses from reserved type 2 frames takes place by starting Routine 1 (if starting is enabled), when the frame doesn't contain an RIF (or for all reserved type 2 frames when TBO = HIGH).
7	MROUT	If MROUT is LOW, the Branch Routine Address 0 defined in the BR0START6-0 bits in IB Start Register 1 is selected when a MAC frame is received. If MROUT is HIGH, Branch Routine Address 1 defined in BR1START6-0 is selected.
6	LROUT	If LROUT is LOW, the Branch Routine Address 0 defined in the BR0START6-0 bits in IB Start Register 1 is selected when a LLC frame is received. If LROUT is HIGH, Branch Routine Address 1 defined in BR1START6-0 is selected.
5	1ROUT	When 1ROUT is made LOW, the Branch Routine Address 0 defined in the BR0START6-0 bits in IB Start Register 1 is selected when a reserved type 1 frame is received. If 1ROUT is made HIGH, Branch Routine Address 1 defined in BR1START6-0 is selected.
4	2ROUT	If 2ROUT is LOW, the Branch Routine Address 0 defined in the BR0START6-0 bits in IB Start Register 1 is selected when a reserved type 2 frame is received. If 2ROUT is HIGH, Branch Routine Address 1 defined in BR1START6-0 is selected.
3	0ENBL	If 0ENBL is LOW, Routine 0 is disabled. If 0ENBL is HIGH, Routine 0 can be started.
2	1ENBL	If 1ENBL is set LOW, Routine 1 is disabled. If 1ENBL is HIGH, Routine 1 can be started.
1	2ENBL	If 2ENBL is LOW, Routine 2 is disabled. If 2ENBL is HIGH, Routine 2 can be started.
0	Reserved	
03H: RIF Length Register		
15	Reserved	
14-11	SRFRD3-0	Bits SRFRD3-0 contain the maximum number of RDs-1 for an SRF frame. SRF frames containing more RDs are not copied by the MU9C8148.
10	Reserved	
9-6	ARERD3-0	Bits ARERD3-0 contain the maximum number of RDs-1 for an ARE frame. ARE frames containing more RDs are rejected.
5	Reserved	
4-1	STERD3-0	Bits STERD3-0 contain the maximum number of RDs-1 an STE frame can contain. If an STE frame contains more RDs, it is rejected.
0	Zero	Must be set to "0" or LOW.

MU9C8148

REGISTER SET DESCRIPTION (CONT'D)

BIT	NAME	DESCRIPTION
-----	------	-------------

04H: Source Ring Number Register

15-12	ID3-0	ID3-0 contain the version number of the MU9C8148.
11-0	SR11-0	SR11-0 contain the 12-bit Ring Number for this port (Source Ring Number).

05H: Bridge/Destination Ring Number Register A

15-12	BNA3-0	BNA3-0 contain the Bridge Number for remote port A.
11-0	DRA11-0	DRA11-0 contain the Destination Ring Number for remote port A. If DRA11-0 are all LOW, Bridge/Destination Ring combination A is disabled and doesn't take part in SRB comparisons.

06H: Bridge/Destination Ring Number Register B

15-12	BNB3-0	BNB3-0 contain the Bridge Number for remote port B.
11-0	DRB11-0	DRB11-0 contain the Destination Ring Number for remote port B. If DRB11-0 are all LOW, Bridge/Destination Ring combination B is disabled and doesn't take part in SRB comparisons.

07H: Bridge/Destination Ring Number Register C

15-12	BNC3-0	BNC3-0 contain the Bridge Number for remote port C.
11-0	DRC11-0	DRC11-0 contain the Destination Ring Number for remote port C. If DRC11-0 are all LOW, Bridge/Destination Ring combination C is disabled and doesn't take part in SRB comparisons.

08H: Bridge/Destination Ring Number Register D

15-12	BND3-0	BND3-0 contain the Bridge Number for remote port D.
11-0	DRD11-0	DRD11-0 contain the Destination Ring Number for remote port D. If DRD11-0 are all LOW, Bridge/Destination Ring combination D is disabled and doesn't take part in SRB comparisons.

09H: Bridge/Destination Ring Number Register E

15-12	BNE3-0	BNE3-0 contain the Bridge Number for remote port E.
11-0	DRE11-0	DRE11-0 contain the Destination Ring Number for remote port E. If DRE11-0 are all LOW, Bridge/Destination Ring combination E is disabled and doesn't take part in SRB comparisons.

0AH: Bridge/Destination Ring Number Register F

15-12	BNF3-0	BNF3-0 contain the Bridge Number for remote port F.
11-0	DRF11-0	DRF11-0 contain the Destination Ring Number for remote port F. If DRF11-0 are all LOW, Bridge/Destination Ring combination F is disabled and doesn't take part in SRB comparisons.

0BH: Bridge/Destination Ring Number Register G

15-12	BNG3-0	BNG3-0 contain the Bridge Number for remote port G.
11-0	DRG11-0	DRG11-0 contain the Destination Ring Number for remote port G. If DRG11-0 are all LOW, Bridge/Destination Ring combination G is disabled and doesn't take part in SRB comparisons.

0CH: Instruction Buffer (IB)

First Access

15-0	IB15-IB0	IB15-0 contain the information that is written to or read from the D15-0 bits of the IB location (00H to 7FH) pointed to by the address pointer.
------	----------	--

Second Access

15	/W	If LOW, data is written to the LANCAM. If HIGH, data is read from the LANCAM.
14	/CM	If LOW, this instruction is a command. If HIGH, this instruction is data.
13	/EC	If LOW, the LANCAM will output /MF in the case of a match. If HIGH, /MF is held HIGH.
12	S	Special instruction bit. If S is HIGH, the instruction stored at the location pointed to by the address pointer is a MU9C8148 instruction. If S is LOW, the instruction is a LANCAM instruction.

11-0	Reserved	
------	----------	--

REGISTER SET DESCRIPTION (CONT'D)

BIT	NAME	DESCRIPTION
0DH: IB Start Register I		
15	Reserved	
14-8	BR0START6-0	BR0START6-0 contain the Branch Routine Address 0 of the branch routine that can be started by a Wait for match then execute at Branch Routine Address selected instruction.
7	Reserved	
6-0	BR1START6-0	BR1START6-0 contain the Branch Routine Address 1 of the branch routine that can be started by a Wait for match then execute at Branch Routine Address selected instruction.
0EH: IB Start Register II		
15	AUTOSTART3	AUTOSTART3 is used to make Routine 3 an auto starting routine. If this bit is made HIGH, the routine is auto starting at the point in time indicated by SA/DA3.
14	STDIR3	If STDIR3 is programmed HIGH, execution of Routine 3 is started directly. After execution has finished this bit is taken LOW by the MU9C8148.
13	START3	If START3 is made HIGH, execution of Routine 3 is started at the point in time indicated by SA/DA3. START3 is taken LOW by the MU9C8148 after execution has been completed.
12	SA/DA3	If SA/DA3 is made HIGH, execution of Routine 3 takes place directly after the RII has been received. If SA/DA3 is LOW, execution is started after the second C-bit in the FS field.
11	AUTOSTART4	AUTOSTART4 is used to make Routine 4 an auto starting routine. If AUTOSTART4 is programmed HIGH, the routine is auto-starting at the point in time indicated by SA/DA4.
10	STDIR4	If STDIR4 is made HIGH, execution of Routine 4 is started directly. After execution has finished STDIR4 is taken LOW by the MU9C8148.
9	START4	If START4 is HIGH, execution of Routine 4 is started at the point in time indicated by SA/DA4. START4 is taken LOW by the MU9C8148 after execution has been completed.
8	SA/DA4	If SA/DA4 is made HIGH, execution of Routine 4 takes place directly after the RII has been received. If SA/DA4 is LOW, execution is started after the second C-bit in the FS field.
7	AUTOSTART5	AUTOSTART5 is used to make Routine 5 an auto-starting routine. If AUTOSTART5 is set HIGH, the routine is auto starting at the point in time indicated by SA/DA5.
6	STDIR5	If STDIR5 is made HIGH, execution of Routine 5 is started directly. After execution has finished STDIR5 is taken LOW by the MU9C8148.
5	START5	If START5 is set HIGH, execution of Routine 5 is started at the point in time indicated by SA/DA5. START5 is taken LOW by the MU9C8148 after execution has been completed.
4	SA/DA5	If SA/DA5 is set HIGH, execution of Routine 5 takes place directly after the RII has been received. If SA/DA5 is LOW, execution is started after the second C-bit in the FS field.
3	AUTOSTART6	AUTOSTART6 is used to make Routine 6 an auto-starting routine. If AUTOSTART6 is set HIGH, the routine is auto-starting at the point in time indicated by SA/DA6.
2	STDIR6	If STDIR6 is set HIGH, execution of Routine 6 is started directly. After execution is finished, STDIR6 is taken LOW by the MU9C8148.
1	START6	If START6 is set HIGH, execution of Routine 6 is started at the point in time indicated by SA/DA6. START6 is taken LOW by the MU9C8148 after execution has been completed.
0	SA/DA6	If SA/DA6 is set HIGH, execution of Routine 6 takes place directly after the RII has been received. If SA/DA6 is LOW, execution is started after the second C-bit in the FS field.
0FH: Start Address Register I		
15	Reserved	
14-8	STARTI6-0	STARTI6-0 contain the start address of Routine 1.
7	Reserved	
6-0	STARTO6-0	STARTO6-0 contain the start address of Routine 0.
10H: Start Address Register II		
15	Reserved	
14-8	STARTIII6-0	STARTIII6-0 contain the start address of Routine 3.
7	Reserved	
6-0	STARTII6-0	STARTII6-0 contain the start address of Routine 2.

MU9C8148

REGISTER SET DESCRIPTION (CONT'D)

BIT	NAME	DESCRIPTION
11H: Start Address Register III		
15	Reserved	
14-8	STARTV6-0	STARTV6-0 contain the start address of Routine 5.
7	Reserved	
6-0	STARTIV6-0	STARTIV6-0 contain the start address of Routine 4.
12H: Start Address Register IV		
15-7	Reserved	
6-0	STARTVI6-0	STARTVI6-0 contain the start address of Routine 6.
13H: FIFO Control Register		
15-11	Reserved	
10	ENBLFIFO	ENBLFIFO enables/disables the FIFO function in the IB. If this ENBLFIFO is HIGH, the FIFO function is active. If ENBLFIFO is LOW the FIFO function is inactive and the /FULL, /EMPTY signal is set HIGH.
9	RESETFIFO	If RESETFIFO is made HIGH, the FIFO read and write pointer are reset to location 7FH. All data stored in the FIFO is lost after a reset.
8	F/E	If F/E is made HIGH the /FULL, /EMPTY output functions like a FIFO full flag. At the moment the FIFO is filled, the /FULL signal is made LOW. If F/E is LOW, the /FULL, /EMPTY output acts like a FIFO empty flag. It goes LOW when the FIFO is empty.
7	Reserved	
6-0	LIM6-0	LIM6-0 contain the lowest location in the IB the FIFO can use. The FIFO is located between LIM6-0 and 7FH.
14H: FIFO Register		
15-0	FF15-0	FF15-0 contain data that is written in, or read from the FIFO. This data is stored or read from in the location pointed to by the FIFO pointer. If the /FULL flag indicates that the FIFO is full, the data is lost. If the /EMPTY flag indicates that the FIFO is empty, no valid data is read.
15H: Frame Counter		
15-0	FC15-0	The frame counter bits FC15-0 contain the number of frames counted on the Token Ring. It is a 16-bit counter which is increased every time a frame (SD and Token bit set to ONE) is received on the Transceiver Interface. After overflow, this counter restarts at 0000H.
16H: Data Counter		
<i>First Access</i>		
15-0	DC31-16	DC31-16 contain the most significant part of the count of data bytes after the SA received on the Transceiver interface. It stops counting after the ED is received, or an SD in an error situation. If there are other Host Processor cycles between the two consecutive accesses, the result of the second read out will repeat most significant part of the counter. After overflow, this 32-bit counter starts over at zero.
<i>Second Access</i>		
15-0	DC15-0	DC15-0 contain the least significant part of the count of data bytes received from the Token Ring.
17H: Error Counter		
<i>First Access</i>		
15-8	DUPL7-0	DUPL7-0 contain the value of the DUPL0UT counter, which totals the number of frames that were discarded due to a duplicate LOUT on SRF frames. After readout this error counter is reset to 00H.
7-0	IRI7-0	IRI7-0 contain the value of the INVALIDRI counter, which totals the number of frames discarded due to various format errors. After readout this error counter is reset to 00H.

REGISTER SET DESCRIPTION (CONT'D)

BIT	NAME	DESCRIPTION
<i>Second Access</i>		
15-8	DTE7-0	DTE7-0 contain the value of the DUPLANIDORTREEERROR counter, which totals the number of STE frames that were discarded because the pre-stored LOUT already exists in the RIF. After readout this error counter is reset to 00H.
7-0	LIDM7-0	LIDM7-0 contain the value of the LAN ID MISMATCH counter, which totals the number of ARE and STE frames that were discarded because the last LAN ID in the RIF did not equal the preset LIN. After readout this error counter is reset to 00H.
<i>Third Access</i>		
15-8	ALIM7-0	ALIM7-0 contain the value of the ARERDLIMIT EXCEEDED counter, which totals the number of ARE frames discarded due to ARERD Limit exceeded. After readout this error counter is reset to 00H.
7-0	SLIM7-0	SLIM7-0 contain the value of the STERDLIMIT EXCEEDED counter, which totals the number of STE frames discarded due to STERD Limit exceeded. After readout this error counter is reset to 00H.
18H: LANCAM CWEC Register		
15-0	CWEC15-0	Writing to this register starts a direct LANCAM access whereby the data written to CWEC15-0 is placed on the DQ15-0 lines and /W, /CM and /EC are held LOW. This register should not be used while routines are enabled.
19H: LANCAM CREC Register		
15-0	CREC15-0	Reading from this register starts a direct LANCAM access whereby the data read from CREC15-0 is data placed on the DQ15-0 lines by the LANCAM. /CM and /EC are held LOW and /W is held HIGH for this LANCAM cycle. This register should not be used while routines are enabled.
1AH: LANCAM DWEC Register		
15-0	DWEC15-0	Writing to this register starts a direct LANCAM access whereby the data written to DWEC15-0 is placed on the DQ15-0 lines and /W and /EC are held LOW while /CM is held HIGH for this LANCAM cycle. This register should not be used while routines are enabled.
1BH: LANCAM DREC Register		
15-0	DREC15-0	Reading from this register starts a direct LANCAM access whereby the data read from DREC15-0 is data placed on the DQ15-0 lines by the LANCAM. /EC is held LOW and /W and /CM are held HIGH for this LANCAM cycle. This register should not be used while routines are enabled.
1CH: LANCAM CWNEC Register		
15-0	CWNEC15-0	Writing to this register starts a direct LANCAM access whereby the data written to CWNEC15-0 is placed on the DQ15-0 lines and /W and /CM are held LOW while /EC is held HIGH for this LANCAM cycle. This register should not be used while routines are enabled.
1DH: LANCAM CRNEC Register		
15-0	CRNEC15-0	Reading from this register starts a direct LANCAM access whereby the data read from CRNEC15-0 is data placed on the DQ15-0 lines by the LANCAM. /CM is held LOW and /W and /EC are held HIGH for this LANCAM cycle. This register should not be used while routines are enabled.
1EH: LANCAM DWNEC Register		
15-0	DWNEC15-0	Writing to this register starts a direct LANCAM access whereby the data written to DWNEC15-0 is placed on the DQ15-0 lines and /W is held LOW while /CM and /EC are held HIGH for this LANCAM cycle. This register should not be used while routines are enabled.
1FH: LANCAM DRNEC Register		
15-0	DRNEC15-0	Reading from this register starts a direct LANCAM access whereby the data read from DRNEC15-0 is data placed on the DQ15-0 lines by the LANCAM. /EC, /W and /CM are held HIGH for this LANCAM cycle. This register should not be used while routines are enabled.

MU9C8148

ABSOLUTE MAXIMUM RATINGS

Supply Voltage	-0.5 to 7.0 Volts
Voltage on all Other Pins	-0.5 to VCC+0.5 Volts (-2.0 Volts for 10 ns, measured at the 50% point)
Temperature Under Bias	-40°C to +80°C
Storage Temperature	-55°C to +125°C
DC Output Current	20 mA (per Output, one at a time, one second duration)

Stresses exceeding those listed under Absolute Maximum Ratings may induce failure. Exposure to absolute maximum ratings for extended periods may reduce reliability. Functionality at or above these conditions is not implied.

All voltages are referenced to GND.

OPERATING CONDITIONS (voltages referenced to GND at the device pin)

Symbol	Parameter	Min	Typical	Max	Units	Notes
VCC	Operating Supply Voltage	4.75	5.0	5.25	Volts	
VIH	Input Voltage Logic "1" (HIGH)	2.2		VCC+0.5	Volts	
VIL	Input Voltage Logic "0" (LOW)	-0.5		0.8	Volts	-1.0 Volts for 10 ns measured at 50% amplitude, Fig. 5
TA	Ambient Operating Temperature	0		70	°C	Still Air

ELECTRICAL CHARACTERISTICS

Symbol	Parameter	Min	Typical	Max	Units	Notes
ICC	Average Power Supply Current			150	mA	
VOH	Output Voltage Logic "1" (HIGH)	2.4			Volts	IOH = -2.0 mA (Excl. open-drain outputs)
VOL	Output Voltage Logic "0" (LOW)			0.4	Volts	IOL = 8.0 mA
IOH	Output Open-drain Off Current			5	µA	VOH ≤ VCC
IIZ	Input Leakage Current	-5		5	µA	VSS ≤ VIN ≤ VCC
IOZ	Output Leakage Current	-5		5	µA	VSS ≤ VOUT ≤ VCC; DQn = High Impedance

CAPACITANCE

Symbol	Parameter	Min	Typ	Max	Units	Notes
CIN	Input Capacitance			10	pF	f = 1 MHz, VIN = 0 Volts
COUT	Output Capacitance			10	pF	f = 1 MHz, VOUT = 0 Volts

AC TEST CONDITIONS

Input Signal Transitions	0.0 to 3.0 volts
Input Signal Rise and Fall Times	≤ 3 ns
Input Timing Reference Level	1.5 volts
Output Timing Reference Level	1.5 volts
Open-Drain Reference Level	1.5 volts
TTL Switching Test Load	Figure 2
Three-state Test Load	Figure 3
Open-Drain Test Load	Figure 4

SWITCHING CHARACTERISTICS

Arbitration Switching Characteristics

No.	Symbol	Parameter	Min	Typ.	Max	Units	Notes
1	tCHRQL	/RQ LOW from RXC HIGH			17	ns	
2	tCHRQH	/RQ HIGH from RXC HIGH			16	ns	
3	tRQLCH	/RQI to RXC Setup Time	3			ns	

MAC Interface Switching Characteristics

No.	Symbol	Parameter	Min	Typ.	Max	Units	Notes
4	tCHMFH	XMATCH,XFAIL HIGH from RXC HIGH			18	ns	
5	tCHMFL	XMATCH,XFAIL LOW from RXC HIGH			18	ns	
6	tCHFL	/FLUSH LOW from RXC HIGH			18	ns	
7	tCHFLH	/FLUSH HIGH from RXC HIGH			18	ns	

Transceiver Interface Switching Characteristics

No.	Symbol	Parameter	Min	Typ.	Max	Units	Notes
8	tRDCH	RXD to RXC Setup Time	3			ns	
9	tCLCL	RXC period	30	31.25 125		ns	16 Mbit/s TR 4 Mbit/s TR
10	tCLCH	RXC LOW Period	11			ns	
11	tCHCL	RXC HIGH Period	11			ns	
12	tCHRX	RXD from RXC Hold Time	3			ns	

SWITCHING TEST FIGURES

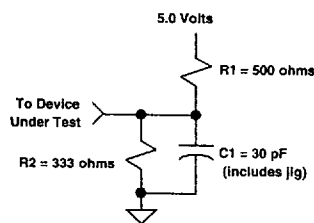

Fig. 2: TTL Switching Test Load

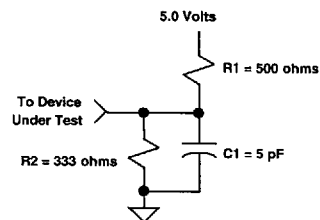

Fig. 3: Three-state Test Load

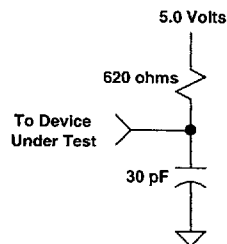

Fig. 4: Open-drain Test Load

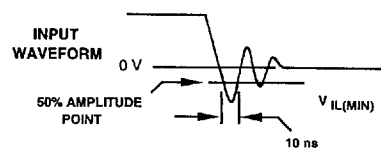

Fig. 5: Input Signal Waveform

MU9C8148

SWITCHING CHARACTERISTICS (CONT'D)						
Host Processor Interface Switching Characteristics						
Intel Mode Timing						
No.	Symbol	Parameter	Min	Max	Units	Notes
13	tSHSL	/CS HIGH Pulse Width	0		ns	
14	tSLKL	/CS LOW to ALE LOW Setup Time	2		ns	
15	tKHL	ALE HIGH Pulse Width	2		ns	
16	tAVKL	Address Bus Valid to ALE LOW Setup Time	2		ns	
17	tKLAX	Address Bus Invalid from ALE LOW Hold Time	5		ns	
18	tKLWRL	ALE LOW to /WS or /RS LOW Setup Time	0		ns	
19	tWBLDL	/WS LOW to /HBDIR LOW Delay Time	tCLCL + 3		ns	
20	tWBEL	/WS LOW to /HBEN LOW Delay Time	tCLCL + 3		ns	
21	tBDLBEL	/HBDIR LOW to /HBEN LOW Delay Time		10	ns	
22	tWLDV	/WS LOW to Data Input Valid Delay Time		3 • tCLCL	ns	
23	tWLRDL	/WS LOW to /HBRDY LOW Delay Time	3 • tCLCL + 3		ns	1, 2
24	tRDLX	/HBRDY LOW to Data Input Invalid Hold Time	tCLCL		ns	
25	tRDLWRH	/HBRDY LOW to /WS or /RS HIGH Setup Time	0		ns	
26	tRWHWRL	/WS or /RS HIGH Pulse Width	2 • tCLCL		ns	
27	tWHBDH	/WS HIGH to /HBDIR HIGH Delay Time	tCLCL + 3	2 • tCLCL + 20	ns	
28	tWHBEH	/WS HIGH to /HBEN HIGH Delay Time	tCLCL + 3	2 • tCLCL + 20	ns	
29	tRWHRDH	/WS or /RS HIGH to /HBRDY HIGH Delay Time	3	tCLCL + 20	ns	
30	tRWHRDZ	/WS or /RS HIGH to /HBRDY Hi-Z Delay Time	tCLCL + 3	2 • tCLCL + 20	ns	
31	tSHRDZ	/CS HIGH to /HBRDY Hi-Z Delay Time	tCLCL + 3	tCLCL + 20	ns	
32	tRLBEL	/RS LOW to /HBEN LOW Delay Time	2 • tCLCL + 3		ns	1
33	tRLRDL	/RS LOW to /HBRDY LOW Delay Time	3 • tCLCL + 3		ns	1, 3
34	tDVRDL	Data Output Valid to /HBRDY LOW Setup Time	2		ns	
35	tRHBEH	/RS HIGH to /HBEN HIGH Delay Time	tCLCL + 3	2 • tCLCL + 20	ns	
36	tRHDZ	/RS HIGH to Data Output Hi-Z Delay Time	tCLCL + 3	2 • tCLCL + 20	ns	
Motorola Mode Timing						
No.	Symbol	Parameter	Min	Max	Units	Notes
37	tSHSL	/CS HIGH Pulse Width	0		ns	
38	tSLDSL	/CS LOW to /UDS or /LDS LOW Setup Time	0		ns	
39	tSRVDSL	SRNW Valid to /UDS or /LDS LOW Setup Time	2		ns	
40	tAVDSL	Address Bus Valid to /UDS or /LDS LOW Setup	2		ns	
41	tDSLBDV	/UDS or /LDS LOW to /HBDIR LOW Delay Time	tCLCL + 3		ns	
42	tDSLBEL	/UDS or /LDS LOW to /HBEN LOW Delay Time	R • tCLCL + 3		ns	1, 4
43	tBDLBEL	/HBDIR LOW to HBEN LOW Delay Time		10	ns	
44	tDSL DV	/UDS or /LDS LOW to Data Input Valid Delay		3 • tCLCL	ns	
45	tDSL RDL	/UDS or /LDS LOW to /HBRDY LOW Delay Time	3 • tCLCL + 3		ns	1, 5
46	tRDLX	/HBRDY LOW to Data Input Invalid Hold Time	tCLCL		ns	
47	tRDLDSH	/HBRDY LOW to /UDS or /LDS HIGH Setup Time	0		ns	
48	tDSHDSL	/UDS or /LDS HIGH Pulse Width	2 • tCLCL		ns	
49	tDSHSRX	/UDS or /LDS HIGH to SRNW Invalid Hold Time	0		ns	
50	tDSHAX	/UDS or /LDS HIGH to Address Bus Invalid Hold	10		ns	
51	tDSHBDX	/UDS or /LDS HIGH to /HBDIR Invalid Delay	tCLCL + 3	2 • tCLCL + 20	ns	

Rev. 5.5 Draft web

MU9C8148

Motorola Mode Timing (con't)							
No.	Symbol	Parameter	Min	Max	Units	Notes	
52	tDSHBEH	/UDS or /LDS HIGH to /HBEN HIGH Delay	tCLCL + 3	2 • tCLCL + 20	ns		
53	tDSHRDH	/UDS or /LDS HIGH to /HBRDY HIGH Delay Time	3	tCLCL + 20	ns		
54	tDSHRDZ	/UDS or /LDS HIGH to /HBRDY Hi-Z Delay Time	tCLCL + 3	2 • tCLCL + 20	ns		
55	tSHRDZ	/CS HIGH to /HBRDY Hi-Z Delay Time	tCLCL + 3	tCLCL + 20	ns		
56	tDVRDL	Data Output Valid to /HBRDY LOW Setup Time	2		ns		
57	tDSDHZ	/UDS or /LDS HIGH to Data Output Hi-Z Delay	tCLCL + 3	2 • tCLCL + 20	ns		
LANCAM Interface Switching Characteristics							
No.	Symbol	Parameter	Min	Typ.	Max	Units	Notes
58	tELEH	/E LOW Period		4 • tCLCL		ns	
59	tEHEL	/E HIGH Period		R • tCLCL		ns	7
60	tCDVEL	Control/Data Setup Time to /E LOW	1			ns	
61	tELCDX	Control/Data Hold Time from /E LOW	120			ns	
62	tDVEH	Data Setup Time to /E HIGH	tCLCL			ns	
63	tEHDX	Data Hold Time to /E HIGH	0			ns	
Notes							
<ol style="list-style-type: none"> If there are routines running due to network activity, access to the device is arbitrated and these times will be extended by an integer number of RXC cycles, the duration of which will be indicated by /INT going LOW. For non-arbitrated accesses, tWLRDL is 3 RXC cycles for Register writes and for the first write to the Instruction Buffer, 6 RXC cycles for the second write to the Instruction Buffer or the FIFO, and 9 RXC cycles for LANCAM writes. For non-arbitrated accesses, tRLRDL is 3 RXC cycles for Register reads, 6 RXC cycles for Instruction Buffer and FIFO reads, and 9 RXC cycles for LANCAM reads. For non-arbitrated accesses, "R" is 1 for Write cycles and 2 for Read cycles. For non-arbitrated accesses, tDSLRDL is 3 RXC cycles for Register and Instruction Buffer writes, 9 RXC cycles for LANCAM writes, 3 RXC cycles for Register reads, 6 RXC cycles for Instruction Buffer reads, and 9 RXC cycles for CAM reads. Although the host interface is asynchronous, RXC is used internally to control operations. Therefore, for modeling purposes, /WS, /RS, /UDS and /LDS can be assumed to have a 10ns setup time with respect to the rising edge of RXC and /INT, /HBRDY and /FULL can be assumed to assert within 20ns of the rising edge of RXC. XMATCH and XFAIL assert four RXC cycles after the /MI input is valid. For a data move from DQ15-DQ0 to address, R is 3. For a data move from address to DQ15-DQ0, R is 4. For a LANCAM register write then read, R is 8. For a LANCAM register write then write, or read then read, R is 9. For a LANCAM register access read then write, R is 10. 							
TIMING DIAGRAMS							
<p>The diagram shows three signals: RXC, /RQ (SLAVE), and /RQI (SLAVE). RXC is a periodic square wave. /RQ (SLAVE) is active-low, with timing points 1 and 2 marked. /RQI (SLAVE) is active-low, with timing point 3 marked.</p>							
MU9C8148 ARBITRATION TIMING							

MU9C8148

TIMING DIAGRAMS (CONT'D)

MAC INTERFACE TIMING FOR THE TMS380CX6

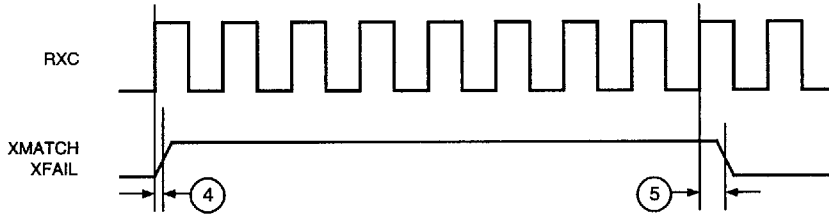

TRANSCEIVER INTERFACE TIMING

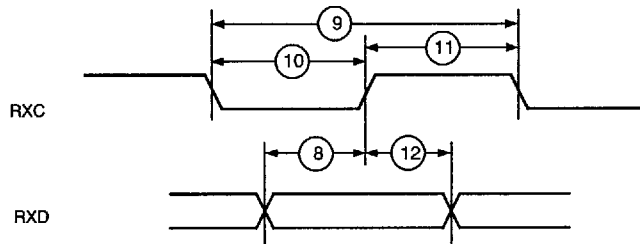

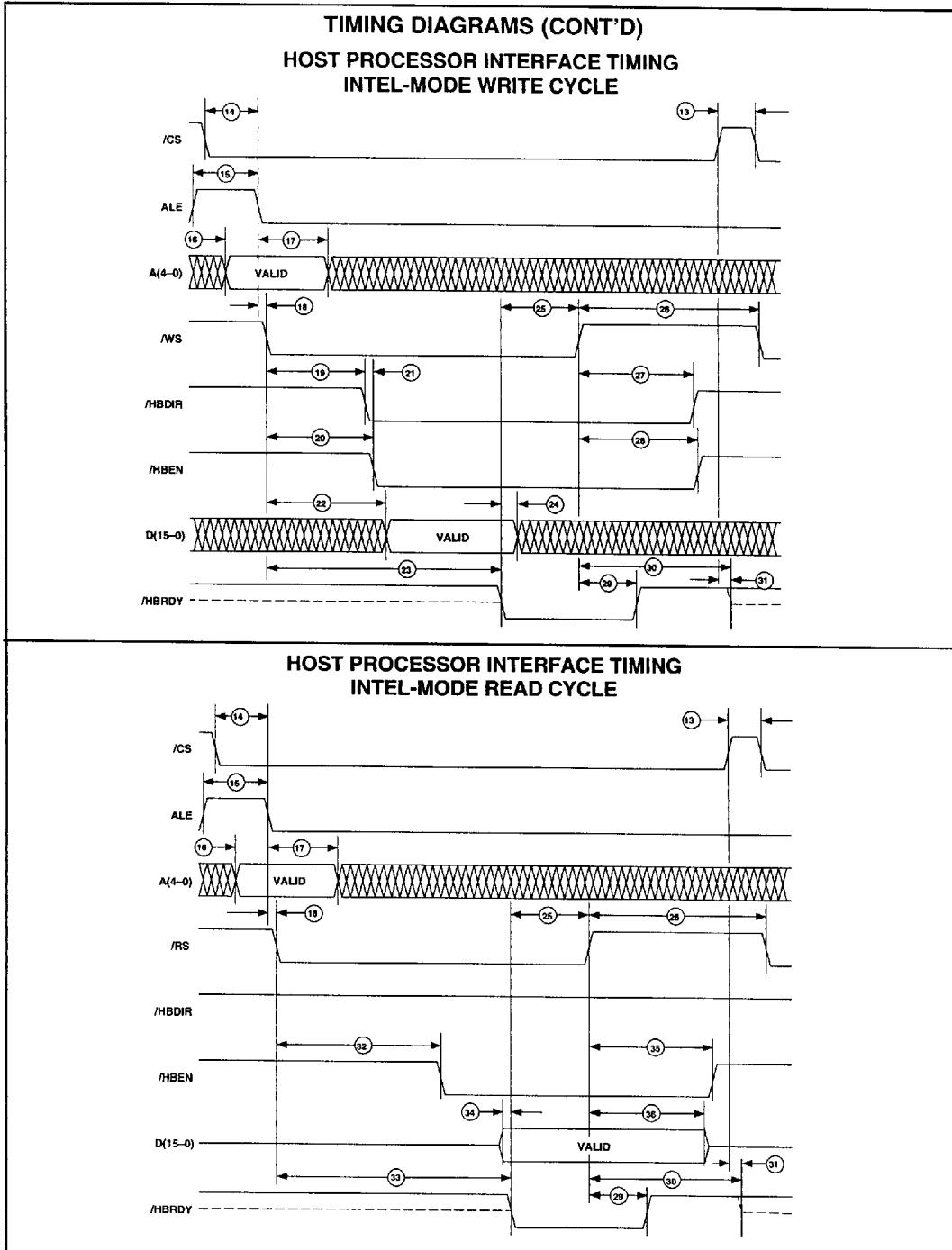

MU9C8148

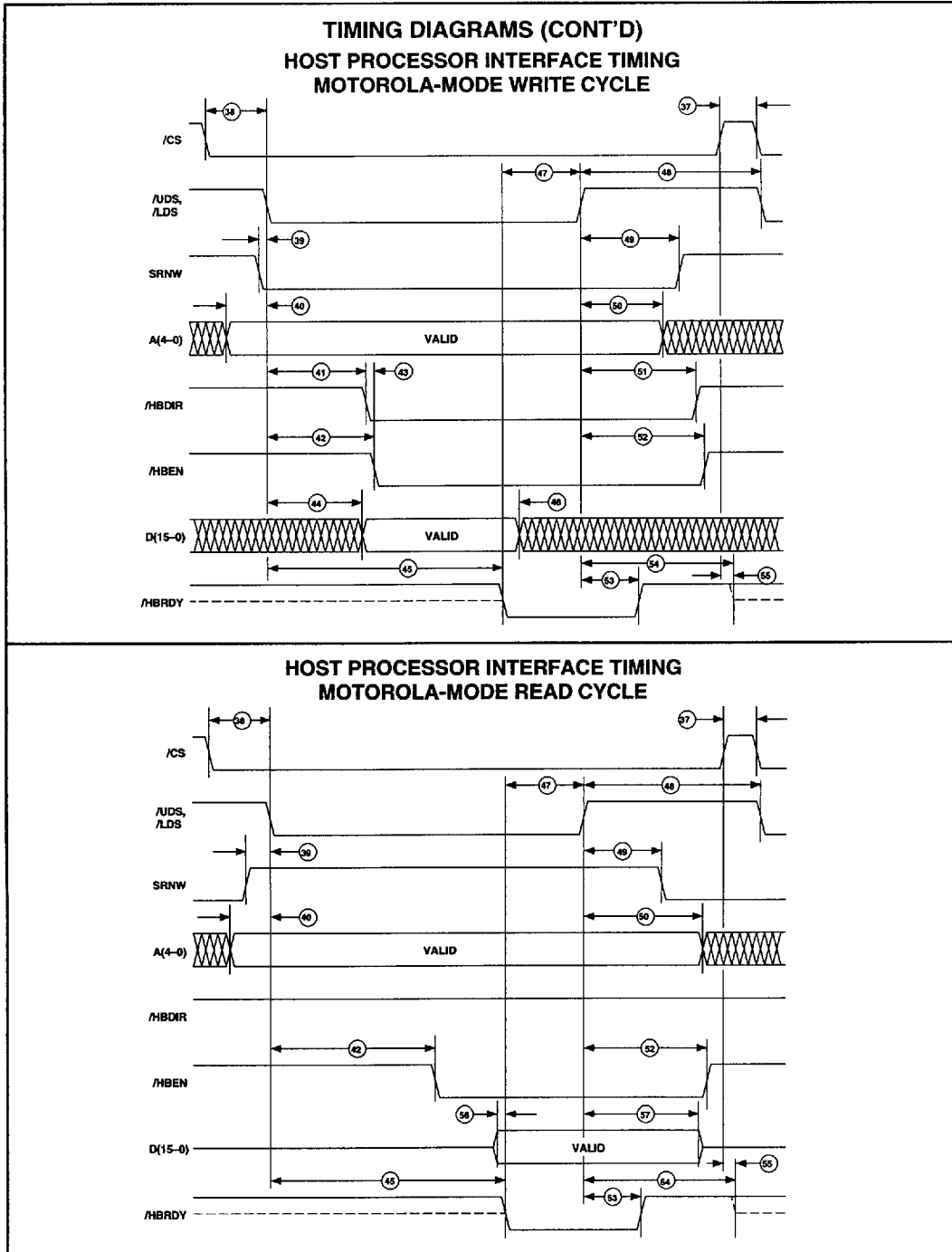

Rev. 5.5 Draft web

TIMING DIAGRAMS (CONT'D)
LANCAM WRITE CYCLE TIMING

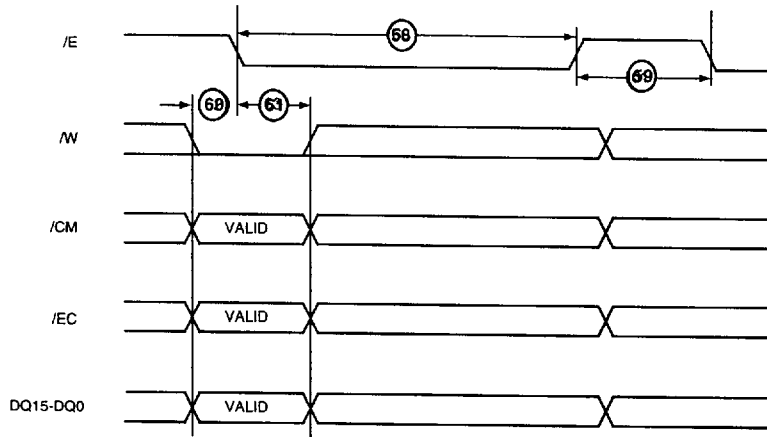

LANCAM READ CYCLE TIMING

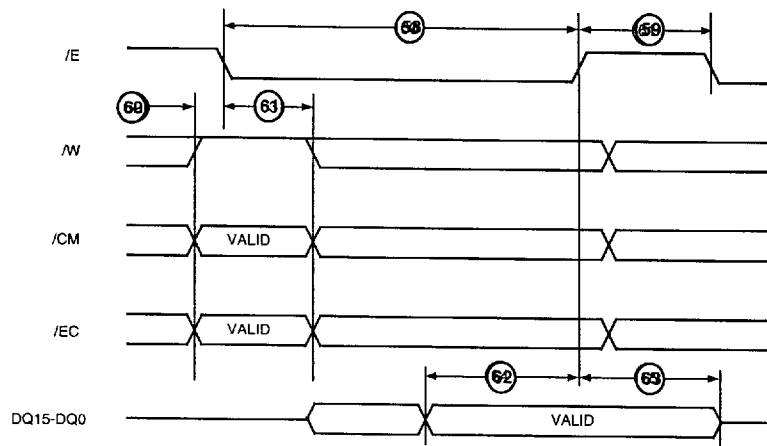

MU9C8148

ORDERING INFORMATION

PART NUMBER	PACKAGE	TEMPERATURE RANGE
MU9C8148-FC	68-PIN PLCC	0-70°C
MU9C8148-TCC	80-PIN TQFP	0-70°C

PACKAGE OUTLINES

Dimensions are in mm.

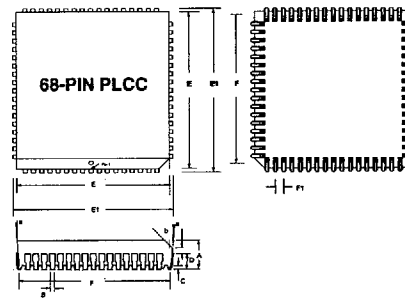
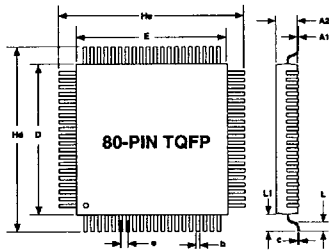

Lead Count	Dim. A1	Dim. A2	Dim. b	Dim. c	Dim. D	Dim. E	Dim. e	Dim. Hd	Dim. He	Dim. L	Dim. L1
80	0.10 ±0.05	1.40 ±0.05	0.32 +0.06 -0.10	0.090 0.200	14.00 ±0.10	14.00 ±0.10	0.65	16.00 ±0.10	16.00 ±0.10	0.60 ±0.15	1.00

Lead Count	Dim. A	Dim. B	Dim. C	Dim. D	Dim. E	Dim. E1	Dim. F	Dim. F1	Dim. a	Dim. b
68	.165 .200	.013 .021	.020 TYP	.070 .110	.950 .958	.985 .995	.890 .930	.050 TYP	3° 6°	45° TYP

MUSIC Semiconductors®

USA Headquarters
MUSIC Semiconductors
254 B Mountain Avenue
Hackettstown, NJ 07840
USA
Tel: (908) 979-1010
Fax: (908) 979-1035

Asian Headquarters
MUSIC Semiconductors
Special Export Processing Zone 1
Carmelray Industrial Park
Canlubang, Calamba, Laguna
The Philippines
Tel: +63 49 549 1480
Fax: +63 49 549 1023/1024
Sales Tel/Fax: +632 723 62 15

European Headquarters
MUSIC Semiconductors
Torenstraat 28
6471 JX Eygelshoven
The Netherlands
Tel: +31-45-5462177
Fax: +31-45-5463663

Visit our Web Site at <http://www.music.com>

MUSIC Semiconductors agent or distributor:

MUSIC Semiconductors reserves the right to make changes to its products and specifications at any time in order to improve on performance, manufacturability, or reliability. Information furnished by MUSIC is believed to be accurate, but no responsibility is assumed by MUSIC Semiconductors for the use of said information, nor for any infringements of patents or of other third-party rights which may result from said use. No license is granted by implication or otherwise under any patent or patent rights of any MUSIC company.

© Copyright 1997, MUSIC Semiconductors