

# GD54/74HC42, GD54/74HCT42

## 1-OF-10 DECODER

### General Description

These devices are identical in pinout to the 54/74LS42. Data on the 4 input pins select one of the 10 outputs corresponding to the value of the BCD number on the inputs. An output will go low when selected, otherwise it remains high. If the input data is not a valid BCD number, i.e., a hexadecimal equivalent greater than 9, all outputs will remain high. These devices are characterized for operation over wide temperature ranges to meet industry and military specifications

### Features

- Low Power consumption characteristic of CMOS devices
- Output drive capability: 10 LS TTL Loads Min.
- Operating speed superior to LS TTL
- Wide operating voltage range: for HC 2 to 6 volts for HCT 4.5 to 5.5 volts
- Low input current: 1 $\mu$ A Max.
- Low quiescent current: 80 $\mu$ A Max. (74HC)
- High noise immunity characteristic of CMOS
- Diode protection on all inputs

### Pin Configuration

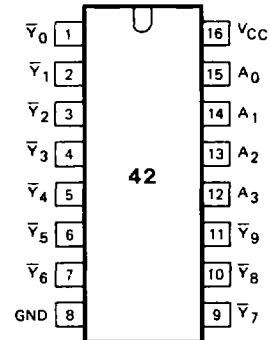

Suffix-Blank Plastic Dual In Line Package  
 Suffix-J Ceramic Dual In Line Package  
 Suffix-D Small Outline Package

### Function Table

INPUTS				OUTPUTS									
A <sub>3</sub>	A <sub>2</sub>	A <sub>1</sub>	A <sub>0</sub>	$\bar{Y}_0$	$\bar{Y}_1$	$\bar{Y}_2$	$\bar{Y}_3$	$\bar{Y}_4$	$\bar{Y}_5$	$\bar{Y}_6$	$\bar{Y}_7$	$\bar{Y}_8$	$\bar{Y}_9$
L	L	L	L	L	H	H	H	H	H	H	H	H	H
L	L	L	H	H	L	H	H	H	H	H	H	H	H
L	L	H	L	H	H	L	H	H	H	H	H	H	H
L	L	H	H	H	H	H	L	H	H	H	H	H	H
L	H	L	L	H	H	H	H	L	H	H	H	H	H
L	H	L	H	H	H	H	H	H	L	H	H	H	H
L	H	H	L	H	H	H	H	H	H	L	H	H	H
L	H	H	H	H	H	H	H	H	H	H	L	H	H
H	L	L	L	H	H	H	H	H	H	H	H	L	H
H	L	L	H	H	H	H	H	H	H	H	H	H	L
H	L	H	L	H	H	H	H	H	H	H	H	H	H
H	H	L	L	H	H	H	H	H	H	H	H	H	H
H	H	L	H	H	H	H	H	H	H	H	H	H	H
H	H	H	L	H	H	H	H	H	H	H	H	H	H
H	H	H	H	H	H	H	H	H	H	H	H	H	H

H=HIGH voltage level  
 L=LOW voltage level

**Absolute Maximum Ratings**

SYMBOL	PARAMETER	CONDITIONS	MIN	MAX	UNIT
$V_{CC}$	DC Supply voltage		-0.5	+7	V
$I_{IK}, I_{OK}$	DC input or output diode current	for $V_i < -0.5$ or $V_i > V_{CC} + 0.5$ V		20	mA
$I_O$	DC output source or sink current	for $-0.5$ V $< V_O < V_{CC} + 0.5$ V		35	mA
$I_{CC}$	DC $V_{CC}$ or GND current			70	mA
$T_{stg}$	Storage temperature range		-65	150	°C
$P_D$	Power dissipation per package	above +70°C derate linearly with 8mW/K		500	mW
$T_L$	Lead temperature	At distance 1.16±1/32 in from case for 60 sec(CERAMIC) 10 sec(PLASTIC)		300 260	°C

**Recommended Operating Conditions**

CHARACTERISTIC	LIMITS		UNITS
	MIN.	MAX.	
Supply-Voltage Range $V_{CC}$ GD54:74HC Types GD54:74HCT Types	2 4.5	6 5.5	V
DC Input or Output Voltage $V_i, V_O$	0	$V_{CC}$	V
Operating Temperature $T_A$ , GD74 Types GD54 Types	-40 -55	+85 +125	°C
Input Rise and Fall times $t_r, t_f$ GD54:74HC Types at 2V at 4.5V at 6V GD54:74HCT Types at 4.5V		1000 500 400 500	ns

**Logic Diagram**

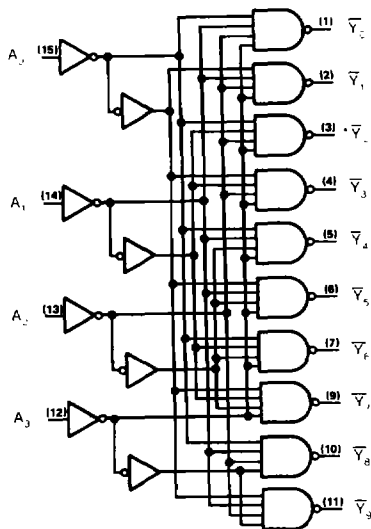

Fig. 1 Logic diagram

DC Electrical Characteristics for HC

SYMBOL	PARAMETER	TEST CONDITION	V <sub>CC</sub> (V)	T <sub>A</sub> =25°C			GD74HC42		GD54HC42		UNIT
				MIN.	TYP.	MAX.	MIN.	MAX.	MIN.	MAX.	
V <sub>IH</sub>	HIGH level input Voltage		2.0	1.5			1.5		1.5		V
			4.5	3.15			3.15		3.15		
			6.0	4.2			4.2		4.2		
V <sub>IL</sub>	LOW level input voltage		2.0			0.3		0.3		0.3	V
			4.5			0.9		0.9		0.9	
			6.0			1.2		1.2		1.2	
V <sub>OH</sub>	HIGH level output voltage	V <sub>IN</sub> =V <sub>IH</sub>	I <sub>OH</sub> =-20μA	2.0	1.9	2.0		1.9		1.9	V
				4.5	4.4	4.5		4.4		4.4	
				6.0	5.9	6.0		5.9		5.9	
	or V <sub>IL</sub>	I <sub>OH</sub> =-4mA	4.5	3.98	4.3		3.84		3.7		
			6.0	5.48	5.2		5.34		5.2		
		I <sub>OH</sub> =-5.2mA									
V <sub>OL</sub>	LOW level output voltage	V <sub>IN</sub> =V <sub>IH</sub>	I <sub>OL</sub> =20μA	2.0			0.1		0.1	V	
				4.5			0.1		0.1		
				6.0			0.1		0.1		
	or V <sub>IL</sub>	I <sub>OL</sub> =4mA	4.5		0.17	0.26		0.33	0.4		
			6.0		0.15	0.26		0.33	0.4		
		I <sub>OL</sub> =5.2mA									
I <sub>IN</sub>	Input leakage Current	V <sub>IN</sub> =V <sub>CC</sub> or GND	6.0			0.1		1.0	1.0	μA	
I <sub>CC</sub>	Quiescent Supply Current	V <sub>IN</sub> =V <sub>CC</sub> or GND I <sub>out</sub> =0μA	6.0			8		80	160	μA	

DC Electrical Characteristics for HCT

SYMBOL	PARAMETER	TEST CONDITION	V <sub>CC</sub> (V)	T <sub>A</sub> =25°C			GD74HCT42		GD54HCT42		UNIT
				MIN.	TYP.	MAX.	MIN.	MAX.	MIN.	MAX.	
V <sub>IH</sub>	HIGH level input Voltage		4.5 to 5.5	2.0			2.0		2.0		V
V <sub>IL</sub>	LOW level input voltage		4.5 to 5.5			0.8		0.8		0.8	V
V <sub>OH</sub>	HIGH level output voltage	V <sub>IN</sub> =V <sub>IH</sub>	I <sub>OH</sub> =-20μA	4.5	4.4	4.5		4.4		4.4	V
				4.5	3.98	4.3		3.84		3.7	
	or V <sub>IL</sub>	I <sub>OH</sub> =-4mA	4.5	3.98	4.3		3.84		3.7		
		I <sub>OH</sub> =-5.2mA									
V <sub>OL</sub>	LOW level output voltage	V <sub>IN</sub> =V <sub>IH</sub>	I <sub>OL</sub> =20μA	4.5			0.1		0.1	V	
				4.5			0.1		0.1		
	or V <sub>IL</sub>	I <sub>OL</sub> =4mA	4.5		0.17	0.26		0.33	0.4		
		I <sub>OL</sub> =5.2mA									
I <sub>IN</sub>	Input leakage Current	V <sub>IN</sub> =V <sub>CC</sub> or GND	5.5			0.1		1.0	1.0	μA	
I <sub>CC</sub>	Quiescent Supply Current	V <sub>IN</sub> =V <sub>CC</sub> or GND I <sub>out</sub> =0μA	5.5			8		80	160	μA	

**AC Characteristics for HC:**  $t_r=t_f=6\text{ns}$   $CL=50\text{pF}$

SYMBOL	PARAMETER	$V_{CC}$ (V)	$T_A=25^\circ\text{C}$			GD74HC42		GD54HC42		UNIT
			MIN.	TYP.	MAX.	MIN.	MAX.	MIN.	MAX.	
$t_{PLH}/$ $t_{PHL}$	Propagation delay time An to $\bar{Y}_n$	2.0		65	150		190		225	ns
		4.5		17	30		38		45	
		6.0		14	26		32		38	
$t_{TLH}/$ $t_{THL}$	Output transition time	2.0		28	75		95		110	ns
		4.5		7	15		19		22	
		6.0		6	13		16		19	

**AC Characteristics for HCT:**  $t_r=t_f=6\text{ns}$   $CL=50\text{pF}$

SYMBOL	PARAMETER	$V_{CC}$ (V)	$T_A=25^\circ\text{C}$			GD74HCT42		GD54HCT42		UNIT
			MIN.	TYP.	MAX.	MIN.	MAX.	MIN.	MAX.	
$t_{PLH}/$ $t_{PHL}$	Propagation delay time An to $\bar{Y}_n$	4.5		19	35		44		53	ns
$t_{TLH}/$ $t_{THL}$	Output transition time	4.5		7	15		19		22	ns

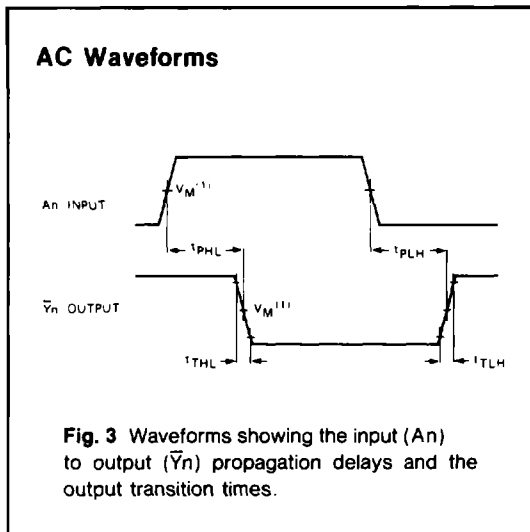

**Note to AC waveforms**

- (1) HC  $V_M=50\%$   $V_L=GND$  to  $V_{CC}$
- HCT  $V_M=1.3V$   $V_L=GND$  to  $3V$