

Helping Customers Innovate, Improve & Grow



The OX-208 is a high stability ovenized crystal oscillator in a 25 x 25 mm package, capable of aging rates of 0.15 ppb/day and temperature stabilities of 0.8 ppb over an industrial temperature range. The Vectron design team will also help develop custom solutions where performance optimization is required for specific applications. Please contact the factory for customization options.

Features

- Reflow Process Compatible
- SC-Cut resonator
- Temperature stability to 0.4 ppb
- Aging rate 0.15 ppb/day
- Frequency Range 5 to 20 MHz
- Standard Frequencies: 5, 10, 20 MHz

Applications

- Holdover reference
- Test equipment
- Synthesizers
- Military communication equipment
- Digital Switching

Performance Specifications

Frequency Stabilities ¹ (Stabilities listed for 10 MHz unless otherwise noted, for stabilities above 10 MHz values may degrade, please contact factory)					
Parameter	Min	Typical	Max	Units	Condition
vs. operating temperature range (referenced to +25°C)	-0.4		+0.4	ppb	0 to +70°C (f=< 10 MHz)
	-0.6		+0.6	ppb	-20 to +70°C (f=< 10 MHz)
	-0.8		+0.8	ppb	-40 to +85°C (f=< 10 MHz)
	-1		1	ppb	0 to +70°C (f>10 MHz)
	-2		2	ppb	-40 to +85°C (f>10 MHz)
For better stability refer to the MX-060 or MX-041 datasheets					
Initial tolerance	-25		+25	ppb	at time of shipment, nominal EFC
vs. supply voltage change	-0.5		+0.5	ppb	V _s ±5%
vs. load change	-0.5		+0.5	ppb	Load ±5%
vs. aging / day	-0.15		+0.15	ppb	after 72 hours operation (f=< 10 MHz)
vs. aging / year	-20		+20	ppb	after 72 hours operation (f=< 10 MHz)
vs. aging / year (following year)	-15		+15	ppb	
vs. aging/ 10 years	-100		+100	ppb	after 72 hours operation (f=< 10 MHz)
vs. aging / day	-0.3		+0.3		after 72 hours operation (f> 10 MHz)
vs. aging / year	-40		+40		after 72 hours operation (f>10 MHz)
vs. aging / year (following year)	-30		+30		after 72 hours operation (f> 10 MHz)
vs. aging / day	-200		+200		
retrace ²	-5		+5	ppb	
Warm-up time			5	minutes	to ±10 ppb of final frequency (1 hour reading) @ +25°C

Performance Specifications

Supply Voltage (Vs)

Parameter	Min	Typical	Max	Units	Condition
Supply Voltage (Vs)	3.135	3.3	3.465	VDC	Ordering Code E
	4.75	5.0	5.25	VDC	Ordering Code D
Power Consumption			4.5	Watts	during warm-up, all temperatures
			2	Watts	steady state @ +25°C
		4.5		Watts	steady state @ -40°C
		1		Watt	steady state @ +85°C

RF Output

start time		1	2	s	time required to achieve 90% of amplitude
Signal [standard]	HCMOS				
Load		15		pF	
Signal Level (Vol)			0.3	VDC	with Vs=3.3V and 15pF Load
			0.4	VDC	with Vs=5.0V and 15pF Load
Signal Level (Voh)	2.5			VDC	with Vs=3.3V and 15pF Load
	3.6				with Vs=5.0V and 15pF Load
Duty Cycle	45		55	%	@ (Voh-Vol)/2
Signal	Sine Wave				
Load		50		Ω	
Output Power @3.3V	2	5	8	dBm	
Output Power @ 5.0V	5	8	11	dBm	
Harmonics			-40	dBc	

Frequency Tuning (EFC)

Tuning Range	±250		±500	ppb	(fixed frequency option available)
Linearity		10		%	
Tuning Slope	Positive				
Input Impedance		100		kOhm	
Bandwidth Modulation	150			Hz	
Control Voltage Range	0.0	1.4	2.8	VDC	with Vs=3.3V
	0.0	2.0	4.0	VDC	with Vs=5.0V

Reference Voltage Output (Vref)

The OX-2080 can be configured with a reference voltage. This configuration requires a custom part number. Please contact the factory for ordering information.

Reference Voltage	2.75	2.8	2.85	VDC	with Vs = 3.3 VDC
	3.92	4.0	4.08	VDC	with Vs = 5.0 VDC

Phase Noise

Parameter	Min	Typical	Max	Units	Condition
Phase Noise ³			-95	dBc/Hz	1 Hz
			-125	dBc/Hz	10 Hz
			-140	dBc/Hz	100 Hz
			-155	dBc/Hz	1 kHz
			-155	dBc/Hz	10 kHz

For lower phase please review the OX-174 datasheet.

Phase Noise			-89	dBc/Hz	1 Hz
			-119	dBc/Hz	10 Hz
			-134	dBc/Hz	100 Hz
			-149	dBc/Hz	1 kHz
			-155	dBc/Hz	10 kHz

Additional Parameters						
Parameter	Min	Typical	Max	Units	Condition	
Allan deviation			5	E-12	1 s tau	
			8	E-12	10 s tau	
			1	E-11	100 s tau	
			5	E-11	1000 s tau	
g-sensitivity		1			ppb/g	
g-sensitivity of 0.5 ppb/g available in this package size. Please contact factory for ordering information. For g sensitivity <0.1 ppb/g please review the OX-043 series.						
Weight			15	g		
Absolute Maximum Ratings						
Supply Voltage (Vs)			6.5	V	with Vs=3.3 & 5.0 VDC	
Output Load			50	pF		
Operable Temperature Range	-55		+95	°C	operable temperature range implies the device will continue to operate with no long-term damage to unit however it will not be specification compliant outside the operating temperature range	
Environmental and Product Classification						
Shock (Endurance)	MIL-STD-202, Method 213, Condition J, 30g 11 ms					
Sine Vibration (Endurance)	MIL-STD-202, Method 201 and 204, Condition A, except 5g to 500 Hz, 1 sweep each axis					
Random Vibration (Endurance)	MIL-STD-202, Method 214, Condition I-D					
Humidity	MIL-STD-202, Method 103, Condition B, 100% rh					
Seal	MIL-STD-202, Method 112, Condition D, hermetic, washable					
Altitude	MIL-STD-202, Method 105, sea level to space					
Resistance to Soldering Heat	MIL-STD-202, Method 210, Condition A,B,C					
Terminal Strength	MIL-STD-202, Method 211, Condition C (5 bends at 45°, 2 lbs)					
Moisture Sensitive Level	1					
RoHS	compliant with exemption 7c-i					
Storage Temperature Range	-55		+125	°C		

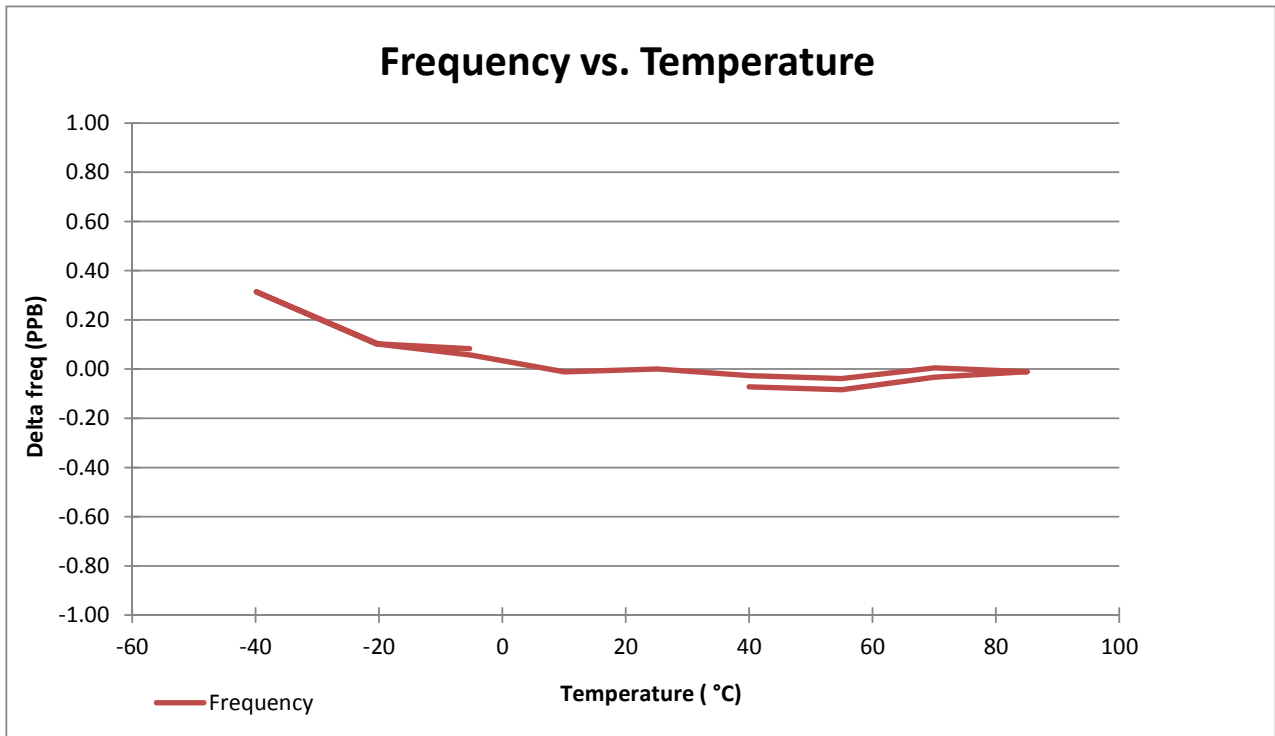

Outline Drawing / Enclosure

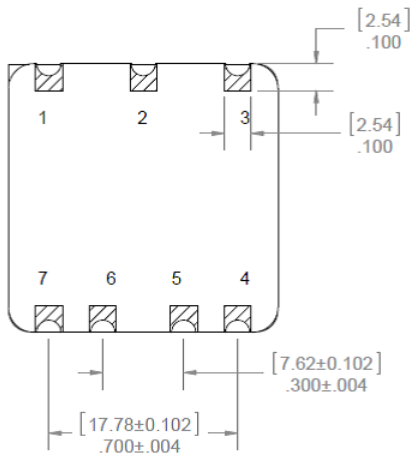
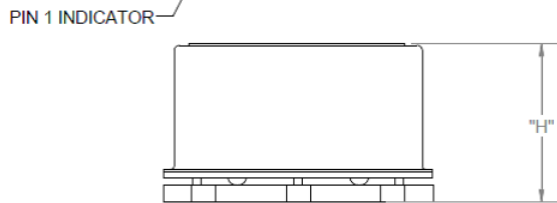
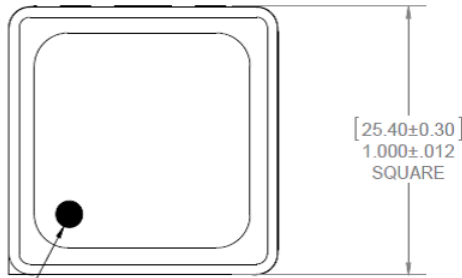
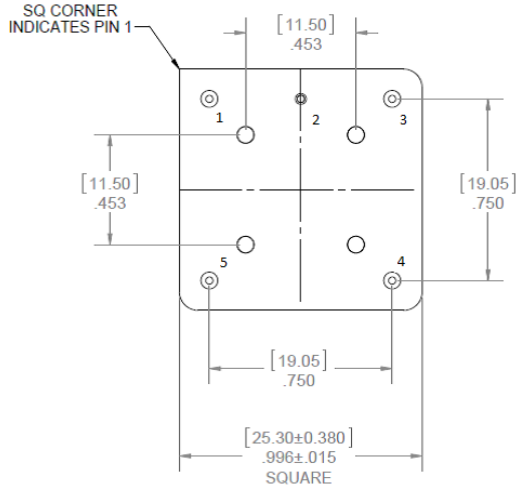
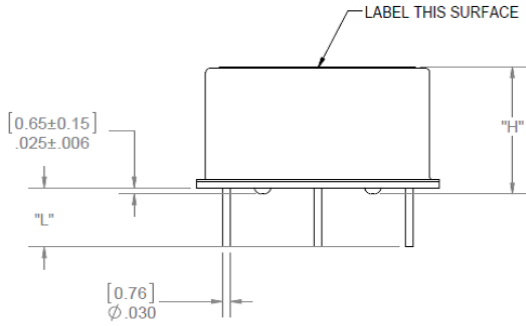

Through hole Package configuration A		
	Height "H"	Pin Length "L"
0	12.7	4.5 mm min

Pin Connections	
1	RF output
2	Ground (Case)
3	Electronic Frequency Control (EFC)
4	Reference Voltage option (requires custom part number)
5	Supply Voltage (Vs)

Dimensions in mm

SMD Package configuration 1	
	Height "H"
1	15.7

Pin Connections	
1	Electronic Frequency Control Input (EFC) No Connect for Fixed frequency Oscillators
2,5,6	No Connect
3	Supply Voltage Input (Vs)
4	RF Output
7	Ground (Case)

Ordering Information⁴

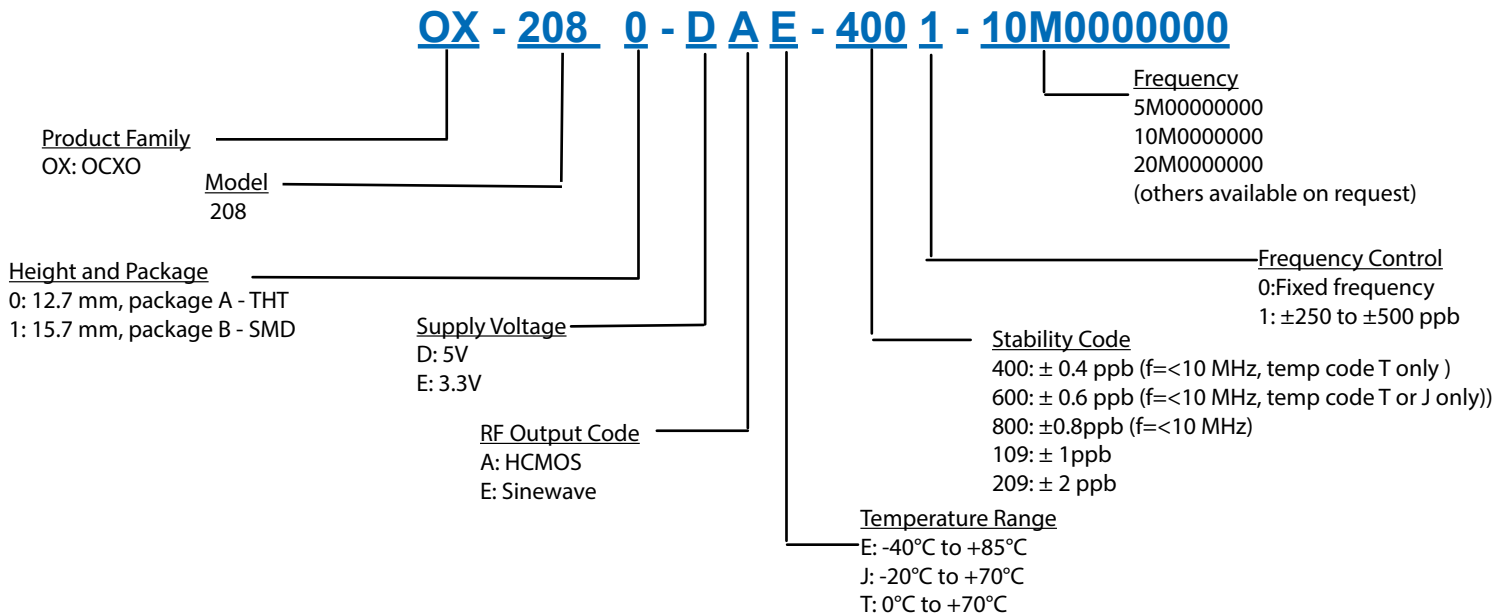

Additional Ordering Options

Additional ordering options available include custom heights, custom aging rates, custom temperature ranges, custom temperature stabilities, custom phase noise requirements, improved g-sensitivity, and oscillators with voltage reference output. on pin 4. These modifications require a custom dash number - please contact the factory for additional information.

Design Tools

Vectron stocks the following items for small orders and prototype development:
OX-2080-DEE-8001-10M00000000
Vectron stocks the following evaluation board for this product:
OCXO Evaluation Board
Application Notes:
None

Notes:

1. Unless otherwise stated, all values are valid after warm-up time and refer to typical conditions for supply voltage, frequency control voltage, load, and temperature (25°C).
2. Retrace defined as f1-fo where fo is the reading after the unit has been on power for 24 hours, and f1 is the frequency after 24 hours off followed by 60 minutes on.
3. Phase noise degrades with increasing output frequency.
4. Not all options and codes available at all frequencies.

Contact Information

USA:

100 Watts Street
Mt Holly Springs, PA 17065
Tel: 1.717.486.3411
Fax: 1.717.486.5920

Europe:

Landstrasse
74924 Neckarbischofsheim
Germany
Tel: +49 (0) 7268.801.0
Fax: +49 (0) 7268.801.281



Information contained in this publication regarding device applications and the like is provided only for your convenience and may be superseded by updates. It is your responsibility to ensure that your application meets with your specifications. MICROCHIP MAKES NO REPRESENTATION OR WARRANTIES OF ANY KIND WHETHER EXPRESS OR IMPLIED, WRITTEN OR ORAL, STATUTORY OR OTHERWISE, RELATED TO THE INFORMATION INCLUDING, BUT NOT LIMITED TO ITS CONDITION, QUALITY, PERFORMANCE, MERCHANTABILITY OR FITNESS FOR PURPOSE. Microchip disclaims all liability arising from this information and its use. Use of Microchip devices in life support and/or safety applications is entirely at the buyer's risk, and the buyer agrees to defend, indemnify and hold harmless Microchip from any and all damages, claims, suits, or expenses resulting from such use. No licenses are conveyed, implicitly, or otherwise, under any Microchip intellectual property rights unless otherwise stated.

Trademarks

The Microchip and Vectron names and logos are registered trademarks of Microchip Technology Incorporated in the U.S.A. and other countries.