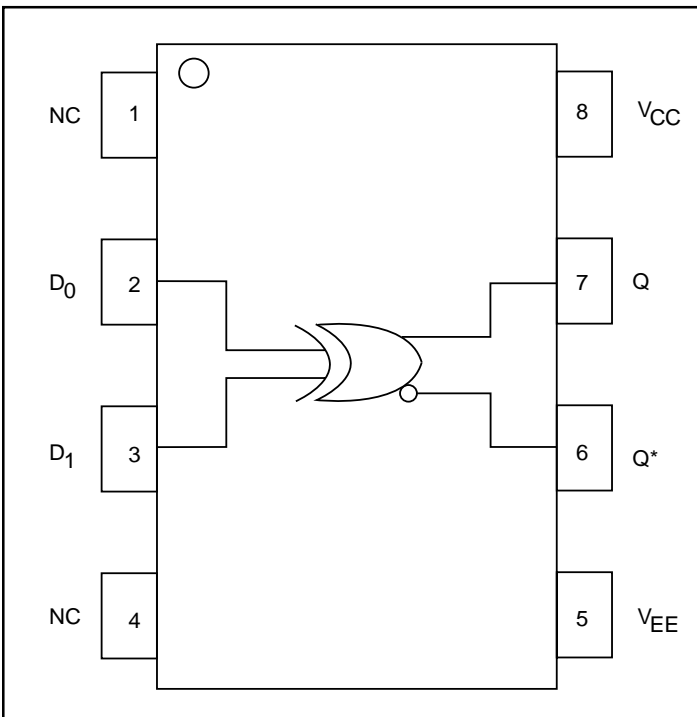

HIGH-PERFORMANCE PRODUCTS
Description

The SK10/100EL07 is a 2-Input XOR / XNOR gate. This device is fully compatible with MC10/100EL07. With propagation delay and output transition time significantly faster than the E107, the EL07 is ideally suited for those applications which require the ultimate in AC performance.

Features

- Extended Supply Voltage Range: (VEE = -5.5V to -4.2V, VCC = 0V) or (VCC = +4.2V to +5.5V, VEE = 0V)
- High Bandwidth Output Transition
- 260ps Propagation Delay
- Internal 75K Ω Input Pulldown Resistors
- Fully Compatible with MC10/100EL07
- ESD Protection >4000V
- Industrial Temperature Range: -40°C to +85°C
- Available in 8 Lead SOIC (150 mils) Package

Functional Block Diagram

PIN Names

Pin	Function
D ₀ , D ₁	Data Inputs
Q, Q*	Differential Data Outputs

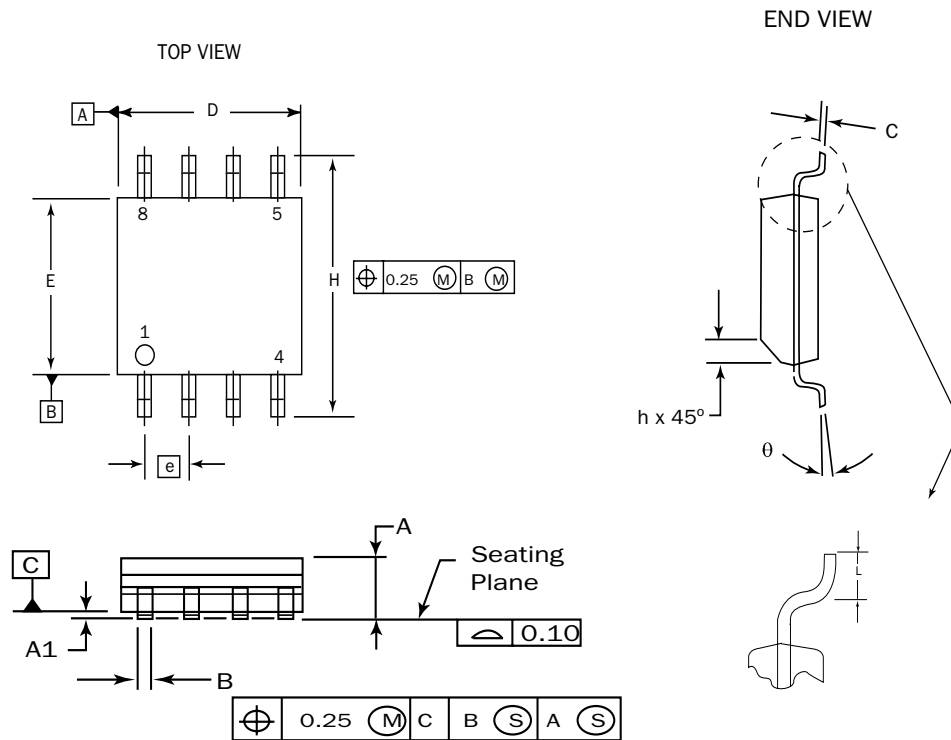
8 Pin SOIC Package



DIM	MILLIMETERS	
	MIN	MAX
A	1.35	1.75
A1	0.10	0.25
B	0.33	0.51
C	0.19	0.25
D	4.80	5.00
E	3.80	4.00
e	1.27 BSC	
H	5.80	6.20
h	0.25	0.50
L	0.40	1.27
θ	0°	8°

NOTES:

1. Dimensions are in millimeters.
2. Dimensions D and E do not include mold protrusion.
3. Maximum mold protrusion 0.15 per side.
4. Dimension B does not include Dambar protrusion. Allowable Dambar protrusion shall be 0.127 total in excess of the B dimension at maximum material condition.

HIGH-PERFORMANCE PRODUCTS
DC Characteristics
SK10/100EL07 DC Electrical Characteristics (Notes 1, 2, 3)

 ($V_{CC} - V_{EE} = 4.2V$ to $5.5V$; V_{OUT} Loaded 50Ω to $V_{CC} - 2.0V$)

Symbol	Characteristic	TA = -40°C			TA = 0°C			TA = + 25°C			TA = +85°C			Unit
		Min	Typ	Max	Min	Typ	Max	Min	Typ	Max	Min	Typ	Max	
I_{IH}	Input HIGH Current D ₀ D ₁			250 150			250 150			250 150			250 150	μA μA
I_{EE}	Power Supply Current 10EL 100EL			14 20			14 20			14 20			14 20	mA mA
$V_{CC} - V_{EE}$	Power Supply Voltage	4.2		5.5	4.2		5.5	4.2		5.5	4.2		5.5	V

AC Characteristics
SK10/100EL07 AC Electrical Characteristics

 ($V_{CC} - V_{EE} = 4.2V$ to $5.5V$; V_{OUT} Loaded 50Ω to $V_{CC} - 2.0V$)

Symbol	Characteristic	TA = -40°C			TA = 0°C			TA = + 25°C			TA = +85°C			Unit
		Min	Typ	Max	Min	Typ	Max	Min	Typ	Max	Min	Typ	Max	
t_{RH} t_{RL}	Propagation Delay Q, Q* (Diff)	160		395	160		380	165		375	165		70	ps
t_r t_f	Output Rise/Fall Times (20% – 80%) Q, Q*	135		275	135		285	135		285	135		290	ps

Notes:

- 10EL circuits are designed to meet the DC specifications shown in the table after thermal equilibrium has been established. The circuit is in a test socket or mounted on a printed circuit board, and transverse airflow than 500 lfm is maintained. Outputs are terminated through a 50Ω resistor to $V_{CC} - 2.0V$.
- 100K circuits are designed to meet the DC specification shown in the table where transverse airflow greater than 500 lfm is maintained.
- For standard ECL DC specifications, refer to the ECL Logic Family Standard DC Specifications Data Sheet.
- For part ordering description, see HPP Part Ordering Information Data Sheet.

HIGH-PERFORMANCE PRODUCTS
Ordering Information

Ordering Code	Package ID	Temperature Range
SK10EL07D	8-SOIC	Industrial
SK10EL07DT	8-SOIC	Industrial
SK100EL07D	8-SOIC	Industrial
SK100EL07DT	8-SOIC	Industrial
SK10EL07U	Die	
SK100EL07U	Die	

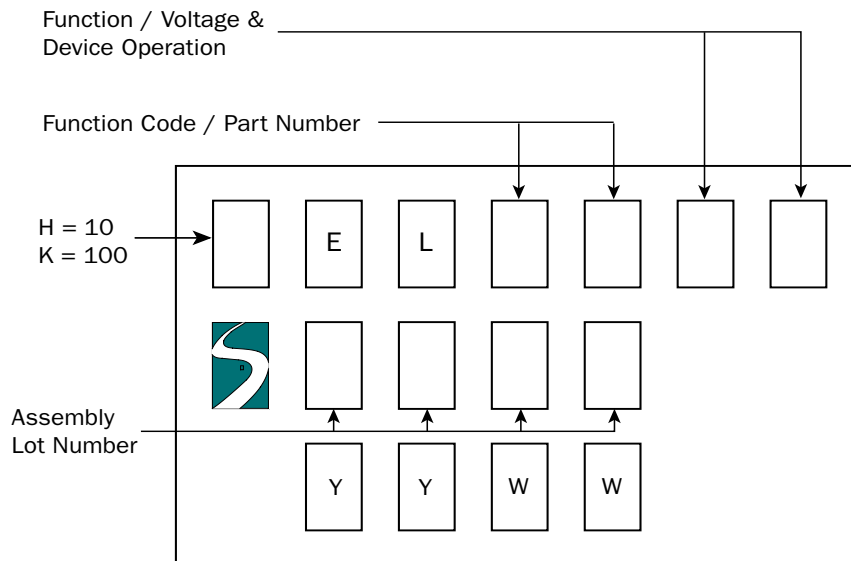
Marking Information
8 PIN SOIC PACKAGE

YY: Last two digits of the Year
 WW: Working Week

Contact Information

Division Headquarters
 10021 Willow Creek Road
 San Diego, CA 92131
 Phone: (858) 695-1808
 FAX: (858) 695-2633

Semtech Corporation
High-Performance Products Division

Marketing Group
 1111 Comstock Street
 Santa Clara, CA 95054
 Phone: (408) 566-8776
 FAX: (408) 727-8994