

DS3875 Futurebus+ Arbitration Controller

General Description

The DS3875 Futurebus+ Arbitration Controller is a member of National Semiconductor's Futurebus+ chip set designed specifically for the IEEE 896.1 Futurebus+ standard. The DS3875 implements Distributed Arbitration and Distributed Arbitration messages in a single chip.

The DS3875 interfaces with Futurebus+ through the DS3885 BTL Arbitration Transceiver and the DS3884A BTL Handshake Transceiver. The DS3885 BTL Arbitration Transceiver incorporates the competition logic needed for the Arbitration Number signal lines. The DS3884A BTL Handshake Transceiver has selectable Wired-OR receiver glitch filtering. The DS3884A is used for the Arbitration Sequencing and Arbitration Condition signal lines.

Additional transceivers included in the Futurebus+ chip set are the DS3883A BTL 9-bit Data Transceiver and the DS3886A BTL 9-bit Latching Data Transceiver. The DS3886A transceiver features edge-triggered latches in the driver which may be bypassed during a fall-through mode and a transparent latch in the receiver. The DS3883A transceiver has no latches in either direction.

The Logical Interface Futurebus+ Engine (LIFE) I/O Protocol Controller with 64-bit Data Path incorporates the Compelled Mode Futurebus+ Parallel Protocol. The Protocol Controller handles all the handshaking signals between the Futurebus+ and the local bus interfaces, and incorporates a DMA Controller with built-in FIFOs for fast queuing.

Features

- The controller implements the complete requirements of the IEEE 896.1 specification as a subset of its features
- Supports Arbitration message sending and receiving
- Supports the two modes of operation (RESTRICTED/UNRESTRICTED)
- Software configurable double/single pass operation, slow/fast, IBA/Parking and restricted/unrestricted modes of arbitration
- Built-in 1 μ s timer for use in the arbitration cycle

- User programmable 16 arbitration delays (8 slow and 8 fast)
- Built-in PLL for accurate delays. The PLL accepts clocks from 2 MHz to 40 MHz in steps of 1 MHz
- Signal to unlock slave modules on transfer of tenure. Auto unlock through a dummy cycle if the current master locked resources
- Programmable delay for releasing ar* after issuing COMPETE/IBA_CMPT. This is to ensure the assertion of the arbitration number during competition, before the release of ar*. Also this delay ensures there is sufficient time to assert the AD/DATA lines during Idle Bus Arbitration before the release of ar*
- Read/Write facility with data acknowledge for the host to load arbitration numbers, an arbitration message, and control registers
- On chip parity generator unloads the host of the additional parity generation function
- Separate interrupts to indicate error occurrence and arbitration message received. Interrupts cleared on a register write. Error status is available in a separate status register
- A special output pin to indicate that a POWERFAIL message was received
- Hardwired register to hold the first word of the arbitration message
- FIFO strobe provided to store more than one arbitration message externally to prevent overrun
- Idle Bus Arbitration (IBA) supported
- Parking implemented
- Bus initialization, system reset and Live-insertion supported. (The logic to detect these conditions must be implemented externally.)
- Testability in the form of reading from key registers which include the STATE, MCW, 1 μ s timer and programmable input clock divider

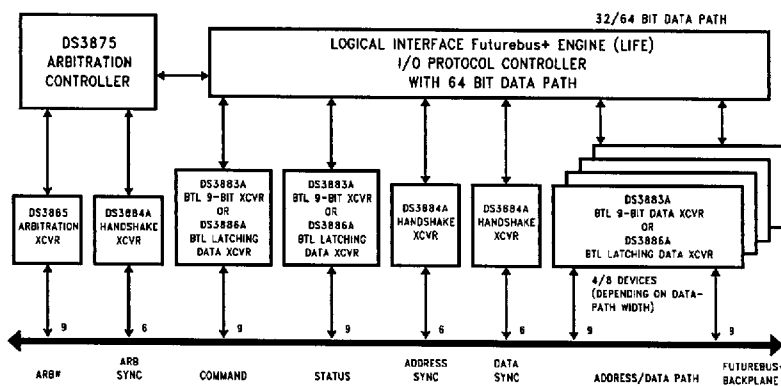

National's Futurebus+ Chip Set Diagram

TL/H/10747-1

Table of Contents

1.0 INTRODUCTION TO FUTUREBUS+	6
2.0 INTRODUCTION TO FUTUREBUS+ ARBITRATION	6
2.1 The Arbitration States	7
3.0 INTRODUCTION TO DS3875 ARBITRATION CONTROLLER	7
3.1 Using the DS3875 in 896.1 Compliant Mode	7
4.0 DS3875 INTERFACES	10
5.0 ARBITRATING FOR FUTUREBUS+	12
5.1 Unrestricted/Restricted Modes of Operation	12
5.2 The Arbitration Number and Arbitration Circuit	12
5.2.1 Priority Field (PR)	14
5.2.2 Round Robin Field (RR)	14
5.2.3 Unique Field (U)	14
5.3 Arbitration Categories	14
5.3.1 Competitor for the Parallel Bus	14
5.3.2 Competitor to Send a Message	15
5.3.2.1 Using an External FIFO to Store Messages	15
5.3.3 By-Stander	15
5.3.4 By-Stander who decides to invoke Preemption	15
5.3.5 Master	15
5.3.6 Master Elect	15
5.4 Futurebus+ Optional Means of Arbitration	17
5.4.1 Idle Bus Arbitration (IBA)	17
5.4.1.1 Masters Support Circuitry to Enable IBA	17
5.4.1.2 Modules Support Circuitry to Participate in IBA	17
5.4.2 Parking	18
5.5 The Arbitration Phases	18
5.5.1 Phase 0, Idle Phase	20
5.5.1.1 Phase 0, Normal Arbitration Events That Cause a Transition to Phase 1	20
5.5.1.2 Phase 0, Idle Bus Arbitration Events That Cause a Transition to Phase 1	21
5.5.1.3 Phase 0, Parking	21
5.5.2 Phase 1, Decision Phase	21
5.5.2.1 Phase 1, Idle Bus Arbitration Events That Cause a Transition to Phase 2	21
5.5.3 Phase 2, Competition Phase	21
5.5.3.1 Phase 2, Idle Bus Arbitration Events That Cause a Transition to Phase 3	21
5.5.4 Phase 3, Error Check Phase	21
5.5.4.1 Phase 3, Idle Bus Arbitration Events That Cause a Transition to Phase 4	22
5.5.5 Phase 4, Master Release Phase	22
5.5.6 Phase 5, Tenure Transfer Phase	22
6.0 THE DS3875 ARBITRATION CONTROLLER SUPPORT OF LOCKING AND UNLOCKING	31
7.0 REGISTER DESCRIPTION	33
7.1 ALL1S	34
7.2 TCXN0	34
7.3 TCXN1	34
7.4 TXMSG	35
7.5 CTRL1	35

Table of Contents (Continued)

7.0 REGISTER DESCRIPTION (Continued)	
7.6 CTRL2	36
7.7 CTRL3	36
7.8 STATE	37
7.9 STATUS	37
7.10 RXCNO	37
7.11 RXCN1	38
7.12 RXMSG	38
7.13 CLRERI	38
7.14 CLRMGI	38
7.15 CLRPMI	38
7.16 REV NO	39
8.0 PROGRAMMING REGISTERS	39
8.1 Host Write Cycle Using Falling Edge of DSACK* (Figure T2a)	39
8.2 Host Write Cycle Using Rising Edge of CS* (Figure T2b)	39
8.3 Host Read Cycle (Figure T2c)	39
9.0 CLOCK/TIMER/DELAY LINES	39
10.0 RESET/INITIALIZATION/POWER UP	40
11.0 LIVE INSERTION	41
12.0 LIVE WITHDRAWAL	42
13.0 TESTING THE DS3875	42
14.0 ELECTRICAL CHARACTERISTICS	43
15.0 AC PARAMETERS	43

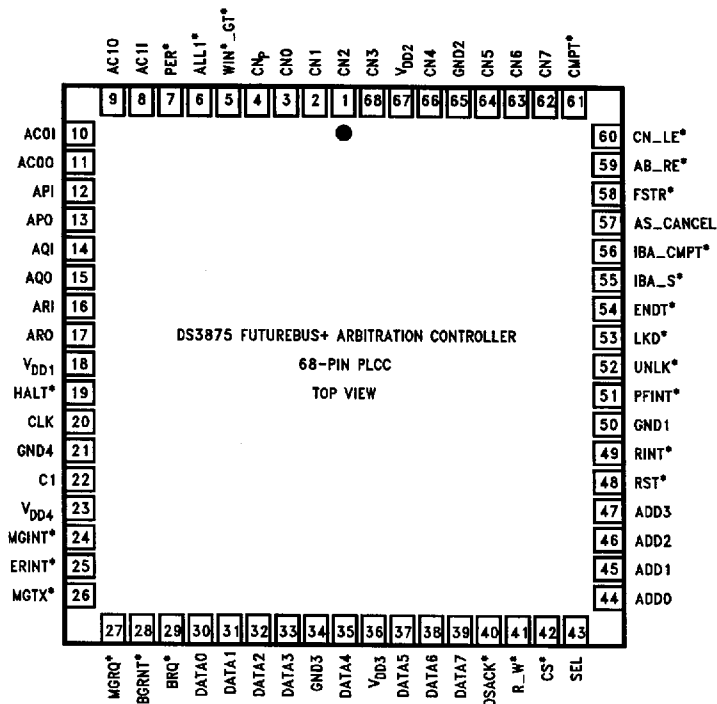

TL/H/10747-2

Pin Definition

Pin	# of Pins	Type	Description
SIGNAL TO/FROM THE HANDSHAKE TRANSCEIVER			
APO	1	O	Arbitration handshake signal from the controller.
AQO	1	O	Arbitration handshake signal from the controller.
ARO	1	O	Arbitration handshake signal from the controller.
AC0O	1	O	Arbitration condition signal from the controller.
AC1O	1	O	Arbitration condition signal from the controller.
API	1	I	Arbitration handshake signal from Futurebus+. This signal is the filtered and inverted version of the Futurebus+ backplane signal AP*.
AQI	1	I	Arbitration handshake signal from Futurebus+. This signal is the filtered and inverted version of the Futurebus+ backplane signal AQ*.
ARI	1	I	Arbitration handshake signal from Futurebus+. This signal is the filtered and inverted version of the Futurebus+ backplane signal AR*.
AC0I	1	I	Arbitration condition signal from Futurebus+.
AC1I	1	I	Arbitration condition signal from Futurebus+.
SIGNAL TO/FROM THE ARBITRATION TRANSCEIVER (Note: These pins are mapped to/from the DS3885 Futurebus+ Arbitration Transceiver.)			
CN(7:0)	8	I/O	The bus to carry competition number to/from the arbitration transceiver.
CNp	1	O	Parity bit of the competition number.
CMPT*	1	O	Enables the Arbitration number onto Futurebus+.
AB_RE*	1	O	Direction control for the competition number bus to/from the transceiver.
CN_LE*	1	O	Latch enable for latching the Arbitration number from the controller into the transceiver.
PER*	1	I	PARITY ERROR: Indicates that a parity error was detected on the winner's arbitration number.
WIN*_GT*	1	I	Win signal when competing/greater than signal when not competing (used to preempt).
ALL1*	1	I	Indicates that all the arbitration number lines on the bus are asserted (used for messages).
SIGNALS TO/FROM THE PARALLEL PROTOCOL CONTROLLER			
BRQ*	1	I	BUS REQUEST: Indicates to the controller to acquire the bus for the module's use.
BGRNT*	1	O	BUS GRANT: Signal asserted by the controller after the detection of a bus request. The module can start using the bus.
RINT*	1	I	Will put the arbitration controller in phase 0 and release all the bus lines except AR*. A selective reset is performed. The rising edge will release controller from phase 0. This reset is to be used for bus initialization.
RST*	1	I	Reset signal from the host. An internal reset is performed. All bus signals are released. The rising edge will put the controller in phase 0 (same as power-up reset).
HALT*	1	I	Will halt the arbitration controller in phase 0. This signal is for use during live insertion.
ENDT*	1	I	END OF TENURE: Indicates the true end of bus tenure of the current master. This line may be asserted only after all the parallel protocol lines are released. (Generated via external logic from BRQ* released.)

Pin Definition (Continued)

Pin	# of Pins	Type	Description
SIGNALS TO/FROM THE HOST (CPU Plus External Interface Logic)			
DATA(7:0)	8	I/O	Data bus for the host to access the register bank of the controller.
ADD(3:0)	4	I	Address bits for the register bank of the controller.
CS*	1	I	CHIP SELECT: The host can read or write to/from the controller.
R_W*	1	I	Read/write signal from the host.
DSACK*	1	O	Data acknowledge pin for host read/write.
SEL	1	I	SELECT: Determines how the controller latches in data. A "1" on the pin uses the rising edge of CS*. A "0" on the pin uses the falling edge of DSACK*.
MGRQ*	1	I	MESSAGE REQUEST: Indicates to the controller to send an arbitration message.
MGTX*	1	O	MESSAGE TRANSMIT: Indicates the successful transmission of an arbitration message.
ERINT*	1	O	ERROR INTERRUPT: Indicates that an error occurred during the arbitration cycle.
MGINT*	1	O	MESSAGE INTERRUPT: Indicates the reception of an arbitration message.
PFINT*	1	O	POWER FAIL INTERRUPT: Indicates that a powerfail message was received.
EXTERNAL LOGIC			
IBA_CMPT*	1	O	Signal to indicate that the Parallel Protocol controller may assert its bit on the ADDRESS/DATA bus if it is participating in an Idle Bus Arbitration.
IBA_S*	1	I	This signal indicates that IBA was successful. If this module was a competitor in the IBA competition (IBRQ*), then this module is the winner and now the bus master. If this module was the master, but did not compete in the IBA competition and IBA was successful, then the M bit (Status register) is negated.
AS_CANCEL	1	I	Indicates the start of the disconnection phase of the current master or cancel the current arbitration cycle.
LKD*	1	I	LOCKED: Signal to indicate that resources have been locked in the current tenure and hence generate either a dummy cycle if current master or UNLK* otherwise. (Decoded from Futurebus+ Command port output from Data Path Unit.)
UNLK*	1	O	UNLOCK: Transfer of tenure indication to the parallel protocol controller for unlocking its resources. Generated only if the LKD* signal is asserted. (To external logic.)
FSTR*	1	O	FIFO STROBE: Signal generated to load an external FIFO for received arbitration messages.
CLK	1	I	Clock input to the internal PLL.
C1	1	I	External capacitor input for PLL—0.1 μ F.

1.0 Introduction to Futurebus+

Futurebus+ is a high-performance asynchronous multiplexed address/data backplane bus designed by the IEEE 896.1 committee for use in a wide variety of multiprocessor architectures. The Futurebus+ standard is a next generation backplane bus standard developed to a set of requirements including openness, performance, and system facilities and flexibilities so as not to hinder systems using this bus for many generations of computer systems. Futurebus+ is a single cache coherent backplane architecture featuring scalability, technology independent protocols, and explicit provisions to extend to future applications. Requirements set for the Futurebus+ architecture by the IEEE 896.1 Futurebus+ Working Group include:

1. Architecture, processor, and technology independent
2. A basic asynchronous (compelled) transfer protocol
3. An optional extended source-synchronized protocol
4. No technology-based upper limit to bus performance
5. Fully distributed parallel and arbitration protocols
6. Support for fault-tolerant and high-availability systems
7. Support for cache-based shared memory
8. Compatible message transport definition.

Compatibility of varying speed and technology boards connected to the same Futurebus+ backplane is dependent upon broadcast capability, or a snooping cache coherence scheme. The performance of a Futurebus+ backplane is scalable over time to allow a low-end 32-bit system operating at 100 Mbytes/sec to be expanded to a 256-bit system operating at 3.2 Gbytes/sec in the future. This performance is attainable by the use of source-synchronized protocols which eliminate spatial skews and receivers which are triggered by the incident wave from the driver. The synchronization protocol of the Futurebus+ backplane allows the synchronization domain of the sender to extend along the backplane, presenting only one synchronization interface between the bus and the receiver.

The Futurebus+ backplane uses "Backplane Transceiver Logic" (BTL). BTL is a signaling standard that has been developed to enhance the performance of backplane buses. This standard eliminates the settling time delays, that severely limit the TTL bus performance, to provide significantly higher bus transfer rates. BTL compatible transceivers feature low output capacitance drivers to minimize bus loading, a 1V nominal signal swing for reduced power consumption, and receivers with precision thresholds for maximum noise immunity. For example, all Futurebus+ signals are open collector with termination resistors (selected to match the bus impedance) connected to 2V at both ends. The low voltage is typically 1V. All Futurebus+ signals are active low, indicated by an * after the signal name. (Refer to Table I.) Further, signals can be driven simultaneously by several modules. This requires that glitch filtering will be needed for those times to filter out the transmission line effect called the wire-or glitch. Refer to the Futurebus+ specifications for details.

TABLE I. Signal Definitions

Signal Type, Example Signal	Terminology	Logic Level	TTL	BTL
Active High Signal_Name	Asserted	Logic 1	5V	—
	Negated	Logic 0	0V	—
Active Low Signal_Name*	Asserted	Logic 1	0V	1V
	Negated	Logic 0	5V	—
	Released (Open Collector)	Logic 0	—	2V

2.0 Introduction to Futurebus+ Arbitration

Futurebus+ uses an evolved version of the Parallel Contention Arbiter (see *Figure 4*). Through the application of a unique arbitration vector to this logic, only one contender will be uniquely selected as the winner. This implementation requires no central logic on the backplane and gains the following advantages:

1. The current master can see any requests and their priority to determine whether it should give up the bus.
2. Multiple priority levels can be implemented to allow systems to allocate bus bandwidth to modules running the most critical tasks.
3. A Round Robin (fairness) protocol is implemented within each priority level to ensure fair and equitable allocation of bus tenure to all modules.
4. A master elect can be preempted by a higher-priority contender. This allows the higher priority contender to access the bus with minimum latency (with some sacrifice to the system performance).
5. Arbitration Messages or events can be broadcast on the arbitration bus without disturbing the current transaction on the parallel bus. Important system control functions and interrupts can be sent using this mechanism without the need of dedicated bus lines.
6. A Module may support either Idle Bus Arbitration or Parking. Idle Bus Arbitration can be enabled by the current master to decrease the arbitration latency when any one competitor is requesting the bus. If Idle Bus Arbitration is not selected then Parking may be enabled by the master. Parking allows the current master to regain bus tenure (during Phase 0) to perform new bus transactions.

2.0 Introduction to Futurebus + Arbitration (Continued)

2.1 THE ARBITRATION STATES

Figure 1 is an Arbitration State Diagram showing four states that a module may enter as well as the events that cause the module to change states during the arbitration process. Transitions from one state to another occur only when certain conditions are met, based on the arbitration phase and the arbitration bus lines. Once a control acquisition cycle has started, all modules must participate in the arbitration to remain synchronized within the system.

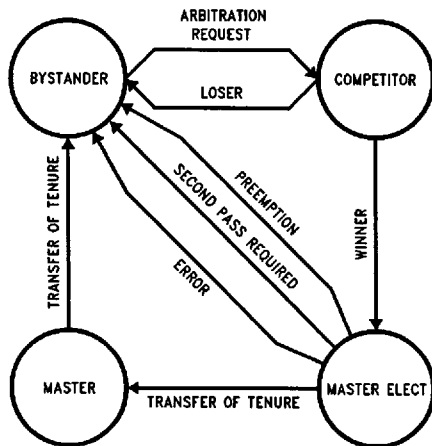

FIGURE 1

TL/H/10747-3

3.0 Introduction to DS3875 Arbitration Controller

The DS3875 Arbitration Controller implements the complete requirements to the IEEE 896.1 specifications. For example, both arbitration modes of operation (Unrestricted and Restricted) are supported. Also, either Idle Bus Arbitration or Parking may be selected for cases when only one request or no request for bus competition exist. The controller is software configurable to operate as a slow/fast module. This selects the minimum time the arbitration controller must wait during the arbitration competition before it can read the resulting competition status. This delay allows arbitration competition lines (AB[7...0]*, ABP*) to settle due to several arbitration numbers being applied to them (Wired bus lines). Further, a built-in PLL, which accepts a clock signal from 2 MHz to 40 MHz, in steps of 1 MHz, controls several programmable delay lines used for releasing ar* after issuing CMPT*/BA_CMPT* (PS(1:0)). This delay compensates for the chip to chip skew to ensure sufficient time to drive the arbitration competition number onto the arbitration competition lines during normal arbitration; or to assert the AD/DATA lines during Idle Bus Arbitration before releasing ar*. Internally, the PLL also generates the 1 µs timer used during arbitration phase 2 and phase 4.

The Arbitration Controller supports Arbitration message sending. A FIFO strobe, FSTR*, is provided to store more

than one arbitration message externally to prevent overrun. Also a hardwired register contains the first word of the arbitration message (h'1ff). Additional registers which hold arbitration numbers, status information, controller configuration information, and an arbitration message can be accessed by the host through Read/Write operations. For outgoing arbitration numbers, the on chip parity generator unloads the host of the parity generation function. For incoming arbitration numbers, the DS3885 Arbitration Transceiver performs the parity check function and drives the PER* input signal to the Controller. Separate interrupt pins for error occurrence, reception of an arbitration message, and reception of Powerfail message are available. These interrupts are cleared by performing a dummy write cycle to these registers.

3.1 DS3875 Futurebus + Arbitration Controller (Distributed) Configuration for IEEE 896.1 Compliance

The DS3875 Futurebus + Arbitration Controller implements the complete requirements of the IEEE 896.1 specification. On chip reset (RST*), the arbiter defaults to the 896.1 compliance configuration features.

The D53875 Distributed Arbiter was designed before the 896.1 specification was finalized. Thus, it contains additional options that can be selected in proprietary bus applications or 896.1 compatible bus applications. There are three features in total that can be chosen through register programming.

First an explanation of each feature will be given, so that if an application can take advantage of the option, it can be programmed. Then, the 896.1 compliance configuration is given so the arbiter will operate in complete accordance with the specification.

Arbitration Number: Unrestricted/Restricted Mode

In Distributed Arbitration, both priority and fairness protocols are implemented. Applications requiring quick access to the Futurebus + backplane can be assigned high priority to reduce bus latency times. Applications with the same (equal) need of the backplane bus, a fairness protocol is guaranteed. Thus, distributed arbitration implements a fairness protocol for modules assigned the same priority classification.

The arbitration competition number encodes this information onto eight lines: AB[7:0] and arbitration number line: ABP. The Arbitration competition number consists of three fields: priority, round robin, and geographical address. Distributed Arbitration protocol allows from 1 to 256 priority levels. Systems not requiring more than two priority levels, a single pass competition number will suffice, one bit for priority. Systems with greater than two priority levels implemented will need a two pass competition number, where eight bits are allocated for priority representation. Now, the competition number exactly contains: 5 bits for geographical address (this guarantees uniqueness), 1 bit for round robin, either 1 bit for priority (single pass), or 8 bits for priority (two pass), and 1 bit to designate if the number is single pass or two pass. (Refer to Table II on page 14.)

When the DS3875 was designed, two modes of operation were defined: Unrestricted and Restricted. The Unrestricted mode allowed one and two pass competition numbers to coexist in a system. The Restricted mode allowed only one pass competition numbers. Now, the 896.1 specification

3.0 Introduction to DS3875

Arbitration Controller (Continued)

only describes one method of operation. This method completely corresponds to the Unrestricted mode. In the DS3875, the R-U* bit in the CTRL2 register, configures the operation mode of the arbiter. On reset, the arbiter is placed in the unrestricted mode, in accordance to the 896.1 specification.

Arbitration Competition Settling Time

Distributed Arbitration uses contention logic to select the winner of the competition cycle. The Arbitration competition begins with all competing modules asserting the most significant bit AB[7], of the competition number onto the backplane lines. A bit wise comparison is performed where modules are allowed to assert the subsequent bits only as long as that module's competition number bits thus far asserted are greater than or equal to the bits seen on the backplane lines. Thus, all competing modules begin asserting their competition numbers onto the backplane lines, but at the end, only the winning module will be allowed to assert its competition number onto the backplane lines.

When the DS3875 was designed, two speeds were allowed in the FBUS+ backplane system for the arbitration competition settling time: Slow or fast. During the arbitration cycle, modules would indicate if they had a fast or slow competition settling time. If any module indicated that it had a slow competition settling time, then all modules would compete using the slow competition settling time, else, the fast settling time would be used during the competition cycle. The DS3875 allows the user to program a fast or a slow competition settling time. One of eight settling times can be selected for each mode with 16 total possible delay times.

The IEEE 896.1 specification now allows each module to use its worst case arbitration settling time, t_A , as the module's delay time to determine its win/lose status for the arbitration competition. The ones and zeros combination in the competition number plays a significant role in determining the numbers settling time. Several factors are incorporated into the t_A calculation:

tpd: Maximum end to end signal propagation delay along the transmission line (backplane). This is a function of the maximum length of the transmission line.

tint: Delay between a change on any arbitration line, ABx*, on the input to a module and the corresponding change on that module's adjacent arbitration output, ab[x-1]*, or abp*, as its competition number is applied to or withdrawn from those bits.

text: Delay between a change on any arbitration line, ABx*, on the input of any other competing module and the corresponding changes on that module's arbitration outputs, ab[x-1]*, or abp*, as its competition number is applied to or withdrawn from those bits.

twin: Maximum delay between the time when the arbitration bus, AB [7..0]*, becomes stable and equivalent to cn[7..0] on the input to a module and the indication within that module that it is the winner.

(Refer to 896.1 for more details).

Thus, now each module can evaluate its win/lose condition when its t_A time has elapsed. During a particular competition, the winning module's competition number will have the longest worst case settling time since this is the module that has placed all of its competition number bits onto the FBUS+.

To use the DS3875 in the 896.1 compliant mode, the user programs two delay values in the CTRL2 register that are closest to the calculated worst case settling time for the particular competition number. The F_S* bit should correspond to the table (fast or slow) that the most desired delay resides. The CTRL2 register bits PD3 to PD5 program the delay number that corresponds to the fast mode operation, and PD0 to PD2 program the delay number that corresponds to the slow mode operation. Thus, a delay that is closest to the desired delay time should be selected both from the fast (PD3 to PD5) table and the slow (PD0 to PD2) table. The F_S* bit will configure this arbiter in the fast or slow mode of operation.

3.0 Introduction to DS3875 Arbitration Controller (Continued)

CTRL2

7	6	5	4	3	2	1	0
F_S*	R_U*	PD5	PD4	PD3	PD2	PDI	PD0

During the competition cycle, if any module has selected the slow mode of operation, AC0* is asserted during phase 1 for indication to all modules to operate in the slow mode. Thus, each arbitration cycle will determine whether the programmed fast delay value or the programmed slow delay value is used for the arbitration number settling time delay. The range of values in the fast and slow delay tables are very close to each other and in some cases are exactly the same that the desired delay value can be easily chosen. The DS3875 is in complete accordance with 896.1 since AC0* signal now only is evaluated in phase 3, 4, and 5, and the t_A number is individually determined for each number.

Idle Bus Arbitration

Previously, the Futurebus+ specification allowed idle bus arbitration. Idle Bus Arbitration (IBA) gives a module quick access to Futurebus+ when the current master has completed it's transfers. IBA occurs on the parallel highway, AD[31:0] lines. When the arbitration cycle is in phase 0 and the master module is not carrying out transactions, another module initiates normal arbitration and IBA simultaneously. In IBA, each module is assigned a particular AD[31:0] bit to assert if a module wishes to get tenure of the bus. If more than one module asserts a bit onto the address/data lines then normal arbitration on the arbitration bus lines will determine the new master. If only one module asserted a bit on the address/data line, then during phase 2 of the normal arbitration cycle that module will be given a bus grant signal. Thus, IBA was specified to speed up the arbitration process when there are not multiple contenders for the bus.

IEEE 896.1 no longer allows IBA. Now, only Parking is allowed. It lets the current Futurebus+ master quickly access the bus to perform other transfers when no other modules want to use it. Parking issues the BGRNT* signal to the current bus master during Phase 0.

For IEEE 896.1 compliance in the DS3875, the IBA_PK* bit of the CTRL3 register should disable IBA and enable Parking. On chip reset, Parking is selected. The IBA_CMPT* output signal of the DS3875 should not be connected and IBA_S* input signal should be connected to V_{CC}.

Concluding Remarks

In retrospect, features which are no longer part of IEEE 896.1 specification were discussed. All of these features are user selectable. The DS3875 can be easily configured to operate in the 896.1 compliance mode. As a matter of fact, on power up reset, the DS3875 is configured in the compliance mode. Briefly:

1. Arbitration Number:

CTRL2 register: R_U* bit

Unrestricted mode now corresponds with the 896.1 arbitration number representation scheme.

2. Arbitration Settling Time Delay:

CTRL2 register: Program as desired.

Select a delay from the fast table and slow table that closely matches the worst case arbitration settling time number, t_A.

3. IBA:

CTRL3 register: IBA_PK* bit

Enable Parking for 896.1 compliance which simutanously disables IBA.

4.0 DS3875 Interfaces

The Arbitration Controller interfaces with the DS3884A Handshake Transceiver, DS3885 Arbitration Transceiver, host with other support chips, Protocol Controller, and Reset and Initialization logic.

Figure 2 depicts an internal block diagram of the DS3875 Arbitration Controller. Figure 3 shows the interface between the DS3875 Arbitration Controller and the other logic on the module.

The DS3884A Handshake Transceiver drives the arbitration handshake and condition signals to the arbitration controller (API, AQI, ARI, ACOI, AC1I). The Arbitration Controller continuously monitors the Futurebus+ backplane through these signals. Whether the Arbitration Controller is competing in the current control acquisition cycle or not, it drives the arbitration handshake and condition signals (APO, AQO, ARO, ACOO, AC1O) which the handshake transceiver drives onto the Futurebus+ backplane.

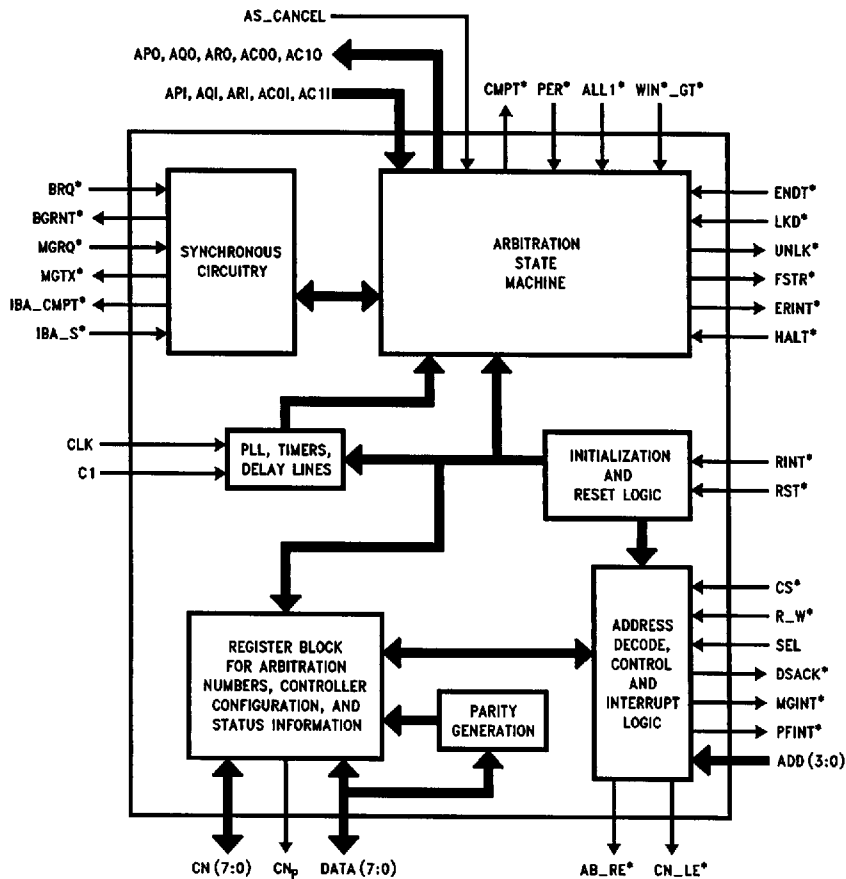

FIGURE 2

TL/H/10747-4

4.0 DS3875 Interfaces (Continued)

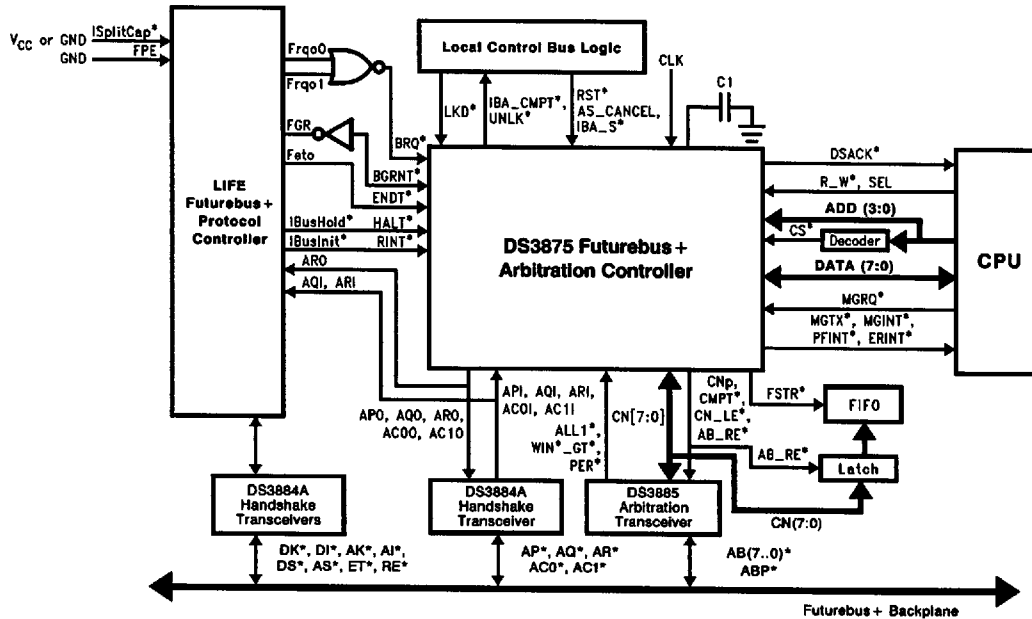

FIGURE 3

TL/H/10747-5

When competing the DS3885 Arbitration Transceiver is enabled to place the competition numbers CN(7...0) and its associated parity bit, CNp, onto the Futurebus+ backplane. During every cycle, whether or not competing, the winning module's arbitration number is read, the value of WIN__GT* signal and PER* signal is determined and updated in the appropriate internal registers.

The host can read or write (R/W) into the Arbitration Controller registers to change the controller configuration, check status, or R/W a new arbitration number/message. The host can select to latch data either on the falling edge of DSACK* or on the rising edge of CS* by releasing or asserting the SEL pin.

The Module may become bus master during Phase 5 if the normal arbitration cycle was successful, Phase 0 if Parking was successful, or Phase 2 if IBA was successful. Upon becoming bus master, the Arbitration Controller will issue BGRNT*. This signal indicates to the Protocol Controller

that it can now perform the desired transactions on the Parallel address/data bus.

The Protocol Controller will let the Arbitration Controller know if it has locked resources by asserting the LKD* signal. If resources were locked, then at transfer of tenure, the Arbitration Controller will issue UNLK* to the Protocol Controller to unlock resources.

A dummy cycle will be initiated by the Arbitration Controller to perform the unlocking function if lock (LKD*) is still asserted after end of tenure (ENDT*) is asserted and no other modules are competing. Unlock will be asserted at the transfer of bus tenure (even if this module wins the competition). If another module initiates arbitration competition this module will participate in the competition and will issue the unlock (UNLK*) signal upon transfer of bus tenure. When the bus transaction is complete and no resources are locked, the Protocol Controller has the option of enabling either Idle Bus Arbitration or parking (IBA_PK* in CTRL3).

4.0 DS3875 Interfaces (Continued)

The input signal ALL1* (AB[7 . . . 0]* and ABp* all asserted) is used to determine if any module is sending an arbitration message during pass 1. For convenience, the Arbitration Controller outputs FSTR* (to an external FIFO) during message reception so more than one arbitration message may be stored by the module.

The Arbitration Controller has dedicated interrupt pins (ERINT*, MGINT*, PFINT*) that interface with the Protocol Controller so that important messages and error indications can be quickly detected.

The Protocol Controller will issue the message request or bus request signals to the DS3875. When a message has been transmitted (Second Pass of arbitration, Phase 5), the Arbitration Controller will assert MGTX*.

On board reset, initialization, power-up, and live insertion logic will inform the Arbitration Controller which type of reset operation to perform: Power-Up Reset (RST*), Initialization (RINT*), or live insertion (HALT*). See Sections 10.0 and 11.0 for more information.

5.0 Arbitrating for Futurebus +

The arbitration process allows a module to seek and gain tenure of Futurebus+ to transfer data to or from another module. The arbitration process is independent of the data transfer process and may take place concurrently with data transactions on Futurebus+. If a module (or several modules) want to use the bus, an arbitration competition takes place. The module with the highest arbitration number gets tenure of the bus.

The National Semiconductor solution to Futurebus+ arbitration includes the DS3875 Arbitration Controller, the DS3885 Arbitration Transceiver and the DS3884 Handshake Transceiver (see front page system block diagram). More information on Arbitration as it applies to the Futurebus+ IEEE standard is available in Section 5 of the "Futurebus+ P896.1 Logical Layer Specification".

5.1 UNRESTRICTED/RESTRICTED MODES OF OPERATION

The Arbitration Controller supports either the Unrestricted or the Restricted mode of arbitration. In the system environment, all modules must be configured to operate in the same mode at any given time.

During initialization, the Unrestricted mode is set since it must be supported by all modules. The Unrestricted mode allows a single pass of an 8-bit arbitration number or a two pass of a 16-bit arbitration number to be used.

Futurebus+ allows arbitration numbers requiring a single pass control acquisition cycle to be mixed with those requir-

ing a two pass control acquisition cycle. During the first pass of a two pass cycle, more than one module may have the same number; however, during the second pass only one winner results where the competition numbers must be unique. A logic zero in the RU__ bit of the CTRL2 register selects the unrestricted mode.

The Restricted mode of operation is optional and is selected by setting the RU__ bit to a logic one in the CTRL2 register. This mode limits arbitration numbers to 8 bits. Thus, only a single control acquisition cycle occurs where all numbers are unique. The arbitration numbers are assigned by the module and can be dynamically changed.

5.2 THE ARBITRATION NUMBER AND ARBITRATION CIRCUIT

Each module has a unique arbitration number. When two or more modules compete for the bus, the module with the highest arbitration number will win the competition.

The DS3885 Arbitration Transceiver contains the arbitration circuit. See *Figure 4* for a functional model of the arbitration circuit. A Parallel Contention Arbitration Protocol controls how modules assert and release the AB[7 . . . 0]* and ABp*. After a period of time (ta) the protocol ensures that only the winners arbitration number will remain on the AB[7 . . . 0]* and ABp*.

The arbitration number consists of one or two competition numbers, CN(7 . . . 0). The Arbitration Controller Transmits/Receives the competition number to/from the Arbitration Transceiver. The CN__LE* signal latches the competition number into the transceiver while the AB__RE* signal allows the controller to read in the winner's competition number. Along with the competition number, the Arbitration Controller transmits the CNp bit, the generated parity bit of the competition number, to the Arbitration Transceiver. Odd parity, as specified in the Futurebus+ specifications, is implemented. Thus, CNp is set when even number of ones are present in the competition number. When CN(7 . . . 0) is received from the Arbitration Transceiver, the PER* bit is checked for error detection.

Referring to Table II, in the Unrestricted mode, the CN7 bit indicates if the module requires another arbitration pass. When a one pass and a two pass arbitration number occur in the same control acquisition cycle, the one pass arbitration number will win.

The DS3875 allows the module to dynamically change the arbitration number by writing into the TXCN0 and/or the TXCN1 registers (see Section 7). If the arbitration number is changed during an arbitration cycle it will be used in the next arbitration competition.

The arbitration number is composed of three fields: Priority Field, Round Robin Field, and a Unique Field.

5.0 Arbitrating for Futurebus+ (Continued)

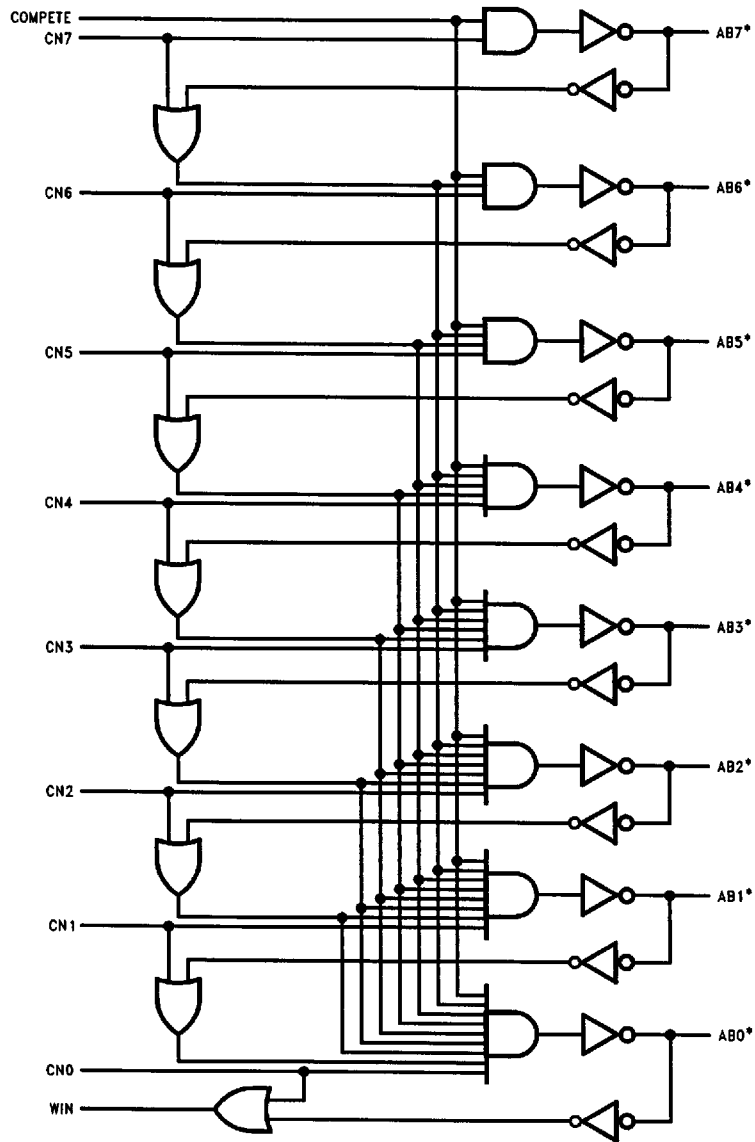

FIGURE 4. Futurebus+ Functional Model of the Arbitration Circuit

TL/H/10747-6

5.0 Arbitrating for Futurebus + (Continued)

5.2.1 Priority Field (PR)

The priority field represents a module's priority class which is determined by the system designer. In the unrestricted mode, the length of this field is a maximum of eight bits while in the restricted mode it is two bits.

5.2.2 Round Robin Field (RR)

This field is represented by a single bit, CN5, in both modes of operation. The round robin protocol ensures that all modules in the same priority class have fair and equal access of the bus. A module is allowed to get tenure of the bus in a sequence defined by its value in the unique field.

The round robin bit is adjusted by the Arbitration Controller each time a transfer of tenure occurs in the module's same priority class whether or not the module is competing in the control acquisition cycle. In the module's same priority class, the round robin bit is set when tenure of the bus is transferred to a module with a larger unique field value or the round robin bit is cleared when tenure of the bus is transferred to a module with a lesser unique field value.

In the event, where the module's arbitration number is changed, after the next control acquisition cycle, the round robin bit is adjusted accordingly.

5.2.3 Unique Field (U)

The five bit unique field, CN(4 . . . 0), guarantees the uniqueness of the module's arbitration number. The unique number may correspond to the module's geographical address or may be allocated by the system designer as he chooses

while also in such a way that minimizes the arbitration settling time. The value "11111" is not allowed in systems using arbitration messages.

5.3 ARBITRATION CATEGORIES

A module can be in one of six categories when a control acquisition cycle is in progress;

- Competitor for the Parallel bus
- Competitor to send a message
- By-Stander
- By-Stander who decides to invoke Pre-emption
- Master
- Master Elect

5.3.1 Competitor for the Parallel Bus

A Module may become a competitor for the parallel bus if it issues a Bus Request (! BRQ*) to the arbitration controller before the arbitration cycle Phase 1 starts, see *Figure 5a*.

If the module issues a bus request and the arbitration cycle is in phase 0, the controller will assert APO to start an arbitration competition. If an arbitration competition has already started, and the module's bus request comes prior to AP* being asserted on the arbitration bus, the module may enter this arbitration cycle. If an arbitration competition has already started, and the module's bus request comes after AP* being asserted on the arbitration bus, the module will have to wait until the next arbitration cycle to compete (or pre-empt the current arbitration cycle in Phase 3).

TABLE II. Arbitration Number

Bit	CN7	CN6	CN5	CN4	CN3	CN2	CN1	CN0
Unrestricted Mode—Single Pass								
Pass 1	1	PR0	RR	U4	U3	U2	U1	U0
Unrestricted Mode—Two Pass								
Pass 1	0	PR7	PR6	PR5	PR4	PR3	PR2	PR1
Pass 2	1	PR0	RR	U4	U3	U2	U1	U0
Restricted Mode								
Pass 1	PR1	PR0	RR	U4	U3	U2	U1	U0
Arbitration Message								
Pass 1	1	1	1	1	1	1	1	1
Pass 2	a7	a6	a5	a4	a3	a2	a1	a0

5.0 Arbitrating for Futurebus+ (Continued)

5.3.2 Competitor to Send a Message

The Arbitration Controller supports message sending. Message sending is implemented in the unrestricted mode in a two pass arbitration cycle. The first pass of all ones (1FF H) in the competition number identifies the transaction as a message. The ALL1* input signal is asserted by the Arbitration Transceiver when it detects 1FF H on the AB[7...0]* and ABp* lines. The arbitration controller has a hardwired register that holds the first pass word. Further, a dedicated pin MGRQ* (message request) places the Arbitration Controller in the message sending mode.

The message that is to be transmitted is loaded into the TXMSG register. The message of 1FF H is reserved as the powerfail message. Other messages are to be coded by the system designer with the greater priority messages having a higher arbitration number. Obviously, if more than one module simultaneously desires to send a message, the message with the highest arbitration number will be transmitted.

When a message is sent, no transfer of tenure takes place. Thus, the master (M) or the round robin (RR) bits are not updated. Upon successfully transmitting the message, MGTX** signal is asserted.

When a message is received by the Arbitration Controller (Phase 5), message interrupt (MGINT*) is asserted and FIFO Strobe (FSTR*) is negated. In the case of a Powerfail message being received; the PFINT* signal is asserted. When the PFINT* signal is asserted, the MGINT* and FSTR* signals are not generated. See *Figure 5d*.

When sending a message, once the MGRQ* signal is asserted, until the message has been transmitted, all other requests are blocked. Upon the MGTX* signal being released, the message request signal will be reevaluated to see if another message needs to be sent.

If this module is the module sending the arbitration message, then the message interrupt (MGINT*) or the Powerfail interrupt (PFINT*) will not be generated on this module. These interrupts are generated only upon the reception of a message from another module. Refer to *Figure 5e*.

5.3.2.1 Using an External FIFO to Store Messages

The Arbitration Controller provides a FIFO strobe (FSTR*) signal to store more than one arbitration message in an external FIFO. A rising edge on FSTR* is generated upon the reception of an arbitration message.

See *Figure 3* and Timing Diagrams: T6, Phase 2 and Phase 5.

1. FSTR* is always asserted (! FSTR*) during phase 2.

2. FSTR* is negated (FSTR*) during phase 5 given the following conditions.

1. The message is not being sent by this module.
2. This is the second pass of an arbitration message.
3. No errors occurred during this arbitration cycle.
4. This is not a powerfail interrupt message (! PFINT*).

The external latch shown in *Figure 3* is enabled by AB_RE* to temporarily hold the message. While AB_RE* is low (see timing diagrams phase 2 and 5), the latch is fall through. Then, during phase 5 on the rising edge of FSTR*, the message held in the latch will be strobed into the FIFO.

5.3.3 By-Stander

A Module is considered a by-stander in the arbitration competition if it does not issue a Bus Request (! BRQ*) to the arbitration controller before arbitration cycle Phase 1 starts.

5.3.4 By-Stander Who Decides to Invoke Pre-emption

A module with a higher arbitration number than the master elect may initiate a new arbitration cycle to establish a new master. This process, referred to as pre-emption, allows a high priority to acquire tenure of the bus with minimum latency.

Pre-emption is allowed in phase 3 when all of the following conditions are met:

1. the arbitration number is greater than the arbitration number on the bus
2. a bus request signal was recently received
3. did not participate in the arbitration competition phase 2.

The master elect may be preempted by asserting AC10.

Pre-emption is not allowed during:

- the first pass of a two pass cycle
- message sending

These two events are given higher precedence.

If a module decides to preempt and changes its competition number during phase 2 or phase 3 in the Arbitration Controller, the Arbitration Transceiver will still use the current latched competition number to make the greater than comparison. When the next arbitration cycle occurs, the new competition number will be used.

5.3.5 Master

The Master is the module that currently has tenure of the parallel bus.

5.3.6 Master Elect

The Master Elect is the module that won the current arbitration cycle. The Master Elect will become master upon transfer of tenure.

5.0 Arbitrating for Futurebus+ (Continued)

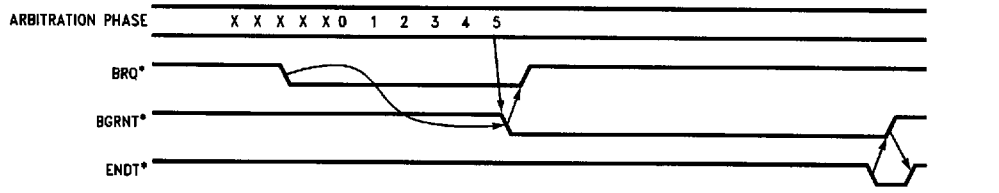

a. Normal Bus Request Timing

TL/H/10747-7

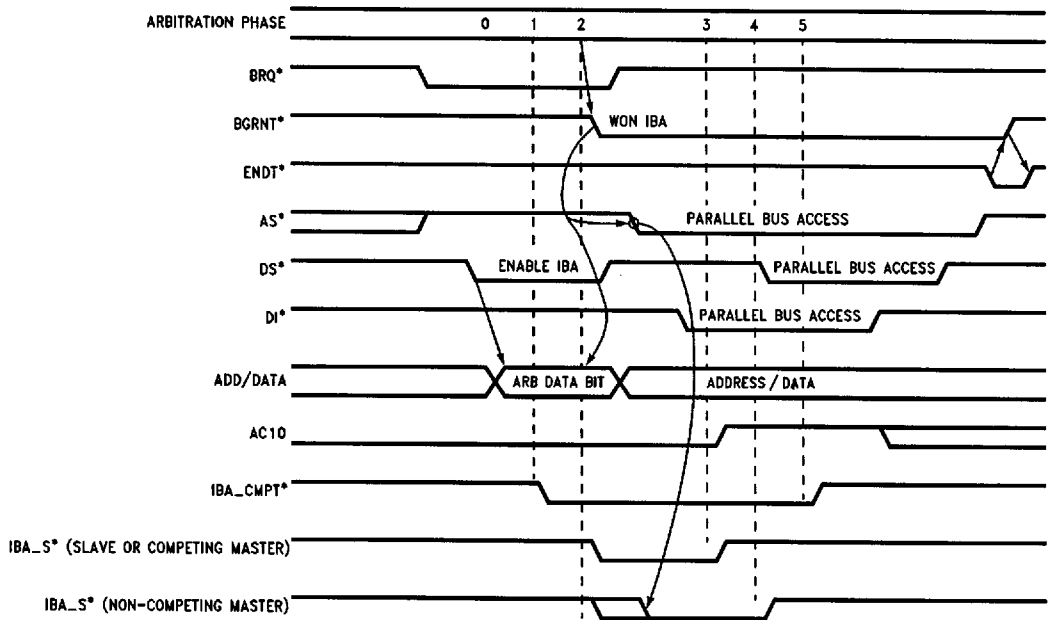

b. Idle Bus Arbitration Timing

TL/H/10747-8

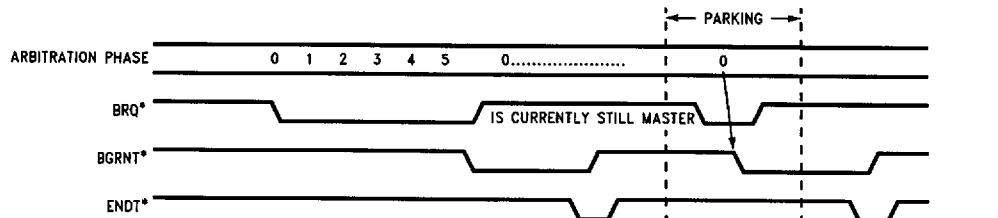

c. Parking

TL/H/10747-9

FIGURE 5. Bus Request Timing (Normal Arbitration, Idle Bus Arbitration and Parking)

5.0 Arbitrating for Futurebus+ (Continued)

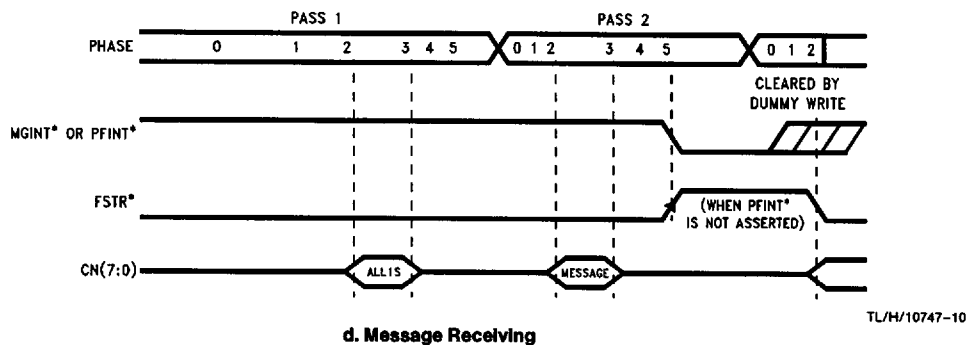

d. Message Receiving

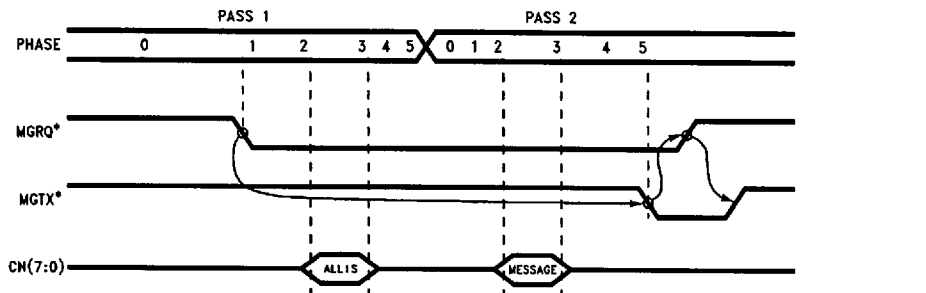

e. Message Sending

FIGURE 5. Bus Request Timing (Normal Arbitration, Idle Bus Arbitration and Parking) (Continued)

5.4 FUTUREBUS+ OPTIONAL MEANS OF ARBITRATION

Besides the normal Futurebus+ Parallel Contention Arbitration, the Futurebus+ Specification allows two other optional arbitration methods to acquire the parallel bus quickly:

- Idle Bus Arbitration
- Parking

Both of these arbitration methods are supported by the National Semiconductor DS3875 Arbitration Controller.

5.4.1 Idle Bus Arbitration (IBA)

Idle Bus Arbitration (IBA) is selected by setting the IBAPK* bit in CTRL3 register. The aim of IBA is to give a module quick access to Futurebus+ when the current master has completed its transfers.

IBA is invoked the same as a normal arbitration bus request (! BRQ*) but uses the parallel bus (AS* negated, DS* asserted, and the parallel address/data bus) to determine the winner of the arbitration cycle, see Figure 5a, b.

During normal arbitration the transfer of Futurebus+ tenure occurs during phase 5. During IBA the transfer of Futurebus+ tenure occurs during phase 2. During IBA the AC10 arbitration condition signal will be asserted by the new master. This will cancel the transfer of tenure during the normal arbitration cycle. Note that Futurebus+ tenure was transferred but only the two modules involved in the IBA (the master and the master elect) know that the transfer of ten-

ure has taken place. All the other modules involved in the normal arbitration cycle see that the transfer of tenure during the normal arbitration cycle was canceled.

If two or more modules have a request, then normal arbitration will determine which module will gain access. IBA takes place on the parallel highway, AD/DATA (31...0). Each module is assigned a bit which is to be asserted during IBA. If only one bit is asserted during the IBA competition, then IBA issues the bus grant signal to that module. Concurrently with IBA, normal arbitration takes place. If a module does not want IBA to issue a bus grant, IBA may be inhibited by asserting DI*. During phase 5, normal arbitration will determine appropriate actions.

5.4.1.1 Masters Support Circuitry to Enable IBA

If IBA is allowed, it is invoked during phase 0. In order to support IBA external logic is needed in addition to the arbitration controller. The Masters external logic must monitor the arbitration control acquisition synchronization signals (AP*, AQ*, AR*) and the parallel bus address handshake signals (AS*, AK*, AI*). If the master supports IBA it should wait until it is ready to end its bus tenure (ENDT* asserted). Then when it releases AS* it should assert ds* to enable modules to participate in IBA competition.

5.4.1.2 Modules Support Circuitry to Participate in IBA

If a module wants to use IBA to gain tenure of Futurebus+ it must use external logic to monitor the arbitration control

5.0 Arbitrating for Futurebus+ (Continued)

acquisition synchronization signals (AP*, AQ*, AR*), the parallel bus address handshake signals (AS*, AK*, AI*), the parallel bus data sync signal (DS*) and data acknowledge inverse (DI*), and the IBA_CPT* output from the arbitration controller.

5.4.2 Parking

During Power Up, the Arbitration Controller is programmed to perform either Idle Bus Arbitration or Parking by setting or clearing the IBAPK* bit in the CTLR3 register. Parking is selected by clearing the IBAPK* bit. The aim of Parking is to give the Futurebus+ bus Master quick access to the bus to perform other transfers when no one else desires to use it. Thus, it is not necessary for the master to go through the entire arbitration cycle to get the BGNT* signal. Parking issues BGNT* in Phase 0, see *Figure 5c*. If another module gets a message request or bus request, the arbitration competition cycle begins like it normally does to handle the request.

All of the following conditions should be met to take advantage of Parking:

1. Parking in selected
2. module must be the current Master
3. ENDT* signal is high
4. BGRNT* signal is high
5. BRQ* signal is asserted low while in phase 0
6. LKD* signal is high (Resources are not locked)

When these conditions are true, the Arbitration Controller issues the BGRNT* signal (asserted low) in phase 0. Upon end of tenure, BGRNT* signal will be released. The Master may continue to use Parking to perform transactions until after the arbitration competition cycle selects a new master (see *Figures 5c* and *7*).

Parking is allowed only when the Master has all resources unlocked (indicated by LKD* signal being high). During phase 0, if the master still has resources locked (ENDT* and BGRNT* signals are high), the Arbitration Controller will immediately initiate a dummy cycle to unlock resources. The UNLK* signal is generated during phase 5 upon the successful transfer of tenure. The transfer of tenure may be with itself or another module.

5.5 THE ARBITRATION PHASES

The arbitration process consists of transitioning through six phases (Phase 0 thru Phase 5) of the three arbitration synchronization signals (AP*, AQ*, AR*). To transition between control acquisition phases only one of the three arbitration synchronization signals will transition.

The Arbitration process is asynchronous and occurs as fast as all the modules that contain arbitration logic can transition through the arbitration phases. If a two-pass arbitration competition has been selected the entire control acquisition cycle is repeated twice.

Each arbitration synchronization signal (AP*, AQ*, AR*) represents the wire-OR of each of the individual synchronization signals from each of the modules. For any of the synchronization signals on the bus to be released, all the modules must release their individual synchronization signals (ap*, aq*, ar*). Therefore, the release of a synchronization signal forms a global synchronization point for all the modules. Likewise, during the assertion of a synchronization signal all modules must remain synchronized by asserting their own signals in response.

Each module must participate in the control acquisition cycle, whether or not the module is competing, to remain synchronized with the other modules. *Figure 6* is a timing diagram of the Control Acquisition Sequence. *Figures 7a-f* are state transition diagrams of the DS3875 Arbitration Controller. Tables III and IV represent the internal register bits that are affected by the arbitration states and their transitions.

The DS3875 Arbitration Controller transitions to the next arbitration phase upon (see *Figure 6*):

1. APO output signal being asserted to phase 1
2. ARI input signal being negated to phase 2. (This input is filtered and indicates all modules have released the AR* synchronization signal on the Futurebus+ backplane.)
3. AQO output signal being asserted to phase 3
4. API input signal being negated to phase 4. (This input is filtered and indicates all modules have released the AP* synchronization signal on the Futurebus+ backplane.)
5. ARO output signal being asserted to phase 5
6. AQL input signal being negated to phase 0. (This input is filtered and indicates all modules have released the AQ* synchronization signal on the Futurebus+ backplane.)

5.0 Arbitrating for Futurebus+ (Continued)

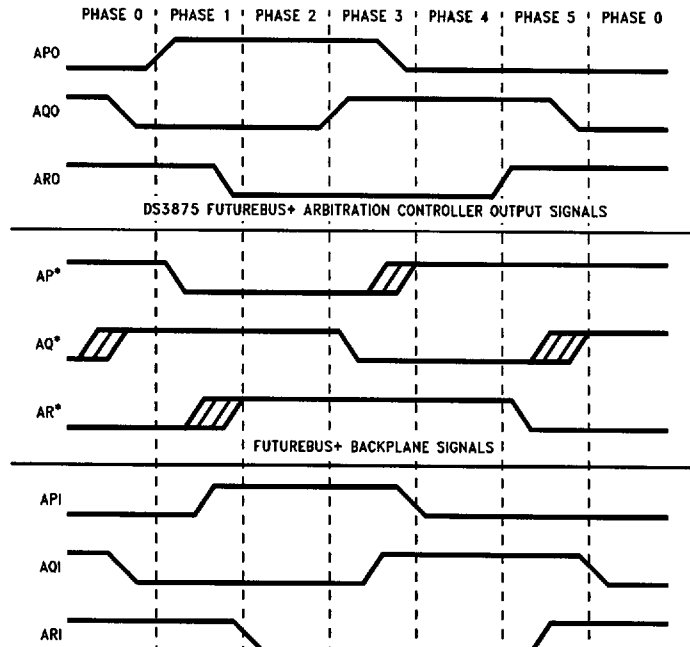

TL/H/10747-12

DS3875 FUTUREBUS+ Arbitration Controller Input Signals
FIGURE 6a. Arbitration Phases

B. Single Access, AS_CANCEL Timing Diagram (AS is tied directly to the AS_CANCEL Input of the Arbitration Controller)

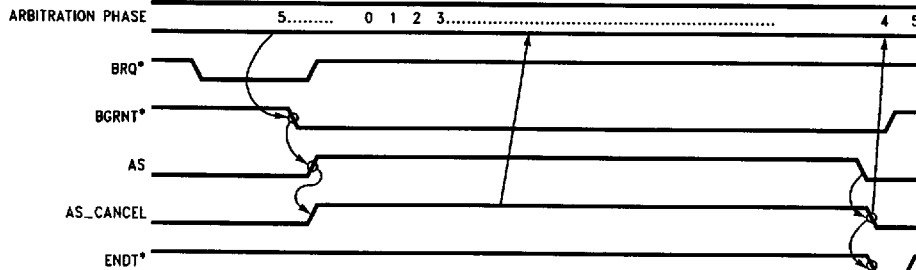

TL/H/10747-13

FIGURE 6b. Timing of the AS_CANCEL Signal

5.0 Arbitrating for Futurebus+ (Continued)

C. Multiple Accesses, AS_CANCEL Timing Diagram (AS is latched before being input to the AS_CANCEL input of the Arbitration Controller. At the end of the last transfer the latch is reset)

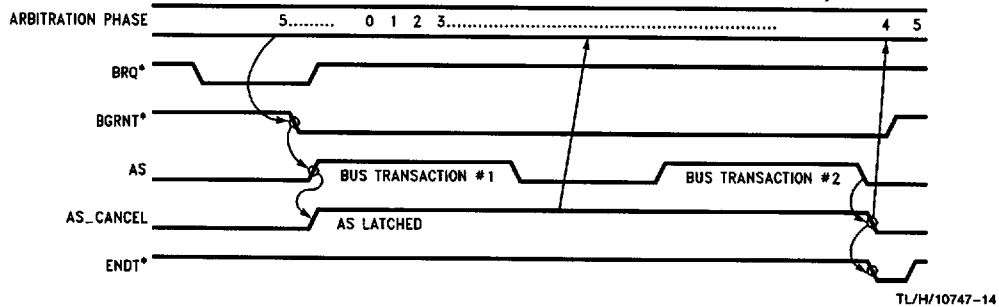

D. Multiple Accesses, AS_CANCEL Timing Diagram (AS is tied directly to the AS_CANCEL input of the Arbitration Controller. The Master must guarantee that the second transfer, or ENDT*, will come within 1 μs of the falling edge of the initial transfer AS signal).

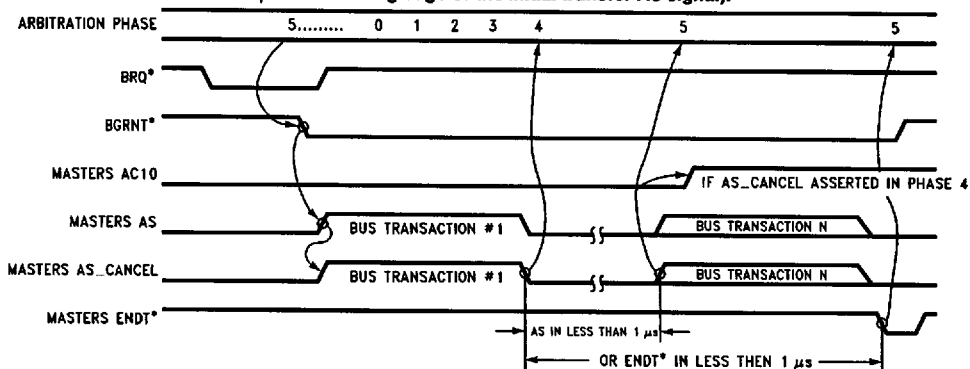

FIGURES 6c, 6d. Timing of the AS_CANCEL Signal

5.5.1 Phase 0, Idle Phase

This Phase is characterized by AP* released and AR* asserted on Futurebus+ and AQf negated on the module board. See *Figure 7a* for the DS3875 Arbitration Controller Phase 0 state diagram.

The arbitration controller will be negating APO, asserting ARO and be receiving AQl negated. This is the state of the arbitration synchronization lines when no control acquisition cycle is in progress or between the two control acquisition cycles of a two-pass arbitration sequence.

While in Phase 0 the following actions are performed:

1. If !HALT* is asserted the arbitration controller will not transition to Phase 1 until HALT* is negated.
2. If any of the "New Bits" are set (NCN, NGO, NDS) the corresponding internal arbitration controller registers will be updated and then the "New Bits" will be reset.
3. The arbitration condition lines (AC1*, AC0*) will be negated.

One of the following three types of arbitration may occur during Phase 0:

1. Normal arbitration
2. Idle Bus Arbitration (IBA)
3. Parking

5.5.1.1 Phase 0, Normal Arbitration Events That Cause a Transition to Phase 1

There are five conditions during normal arbitration where APO will be asserted causing a transition to Phase 1:

1. If Two-Pass Arbitration is selected, a bus request has been received (!BRQ* + !MGRQ* + Dummy Cycle) and this module was a winner during the first pass of arbitration, then APO will be asserted.
2. Though this module may not be requesting Futurebus+ and another module may want to arbitrate for Futurebus+ and assert AP*. This action will cause the AP input (API) on this module to be asserted. API asserted will cause this modules arbitration controller to assert APO.
3. If this module is currently the master and !LK* is asserted, BGRNT* is negated, !ENDT* has been received, no other requests have been received and API is negated, the module will initiate a dummy cycle to unlock its resources by asserting APO (if it is doing Single Pass or the First Pass of Two-Pass Arbitration).
4. A message request (!MGRQ*) will cause APO to be asserted (if it is doing Single Pass or the First Pass of Two-Pass Arbitration). Note that if both a bus request (!BRQ*) and !MGRQ* are received during phase 0,

5.0 Arbitrating for Futurebus+ (Continued)

! MGRQ* will be given a higher priority and will be acted upon during this arbitration cycle. ! BRQ* will wait to arbitrate during the next arbitration cycle.

5. A Bus Request (! BRQ*) will cause APO to be asserted (if it is doing Single Pass or the First Pass of Two-Pass Arbitration). This will cause the Futurebus+ AP* to be asserted and will indicate to the other modules that an arbitration competition is beginning.

Note that the user will violate the Futurebus+ specification if he leaves the local modules resources locked (! LKD*) and has IBA enabled in the arbitration controller. This incident is dangerous because it could lead to another module winning IBA with the local modules resources being locked. If the other module tried to access the local modules resources it would result in deadlock.

5.5.1.2 Phase 0, Idle Bus Arbitration Events That Cause a Transition to Phase 1

If IBA is desired and the arbitration cycle is in Phase 0 (! APO, ! AQI, ARO), the parallel bus is Idle (AS*, AK*, ! AI*), and DS* has been released for a minimum period of time (Futurebus+ spec.) the Masters external logic may assert ! DS*. This will alert any module capable of doing IBA that IBA has been enabled.

5.5.1.3 Phase 0, Parking

The aim of Parking is to give the Futurebus+ bus master quick access to the bus to perform other transfers when no one else desires to use it. If Parking is enabled (! IBA_PK*) and is successful the arbitration controller will issue BGNT* in Phase 0. If another module gets a message request or bus request, the arbitration competition cycle begins like it normally does to handle the request (see Section 5.5.4 for more information).

5.5.2 Phase 1, Decision Phase

This Phase is characterized by AP* and AR* asserted and AQ* released on Futurebus+. See Figure 7b for the DS3875 Arbitration Controller Phase 1 state diagram.

The arbitration controller will be asserting APO and ARO and negating AQO. This is the state of the arbitration synchronization lines when the decision phase (1) is in progress.

During Phase 1 the individual modules must make the decision whether they want to compete. This decision will be based upon the state of the modules bus request, message request or locked status (! BRQ* or ! MSGRQ* or ! LKD*) at the time APO is asserted. Since this condition is subject to metastability a metastable hardened latch is used internal to the DS3875 to resolve this potential condition.

If the module is going to compete the arbitration competition number (CN(7:0)) and its parity bit (CNp) will be asserted to the arbitration transceiver. Latch enable of the arbitration transceiver will be asserted and negated (! CN_LE* asserted for 20 ns) to latch in the arbitration number, and compete will be asserted (! CMPT*) to enable the arbitration competition number onto Futurebus+.

If the module is a slow module (! FS*, see Section 7.6) the arbitration handshake signal ACOO will be asserted.

Once the decision to compete has been made, the arbitration handshake signal (! AC1O) that cancels the arbitration cycle will be negated. The Programmable Skew (PS(1:0)) gives time for the arbitration number to become valid on Futurebus+ before ARO is negated. Once the Programma-

ble Skew has timed out ARO will be negated. Once all modules have negated AR* the arbitration cycle will transition to Phase 2.

Once all modules have negated AR* a 1 μ s timer is started. This timer is used to guarantee that the competition cycle does not get stuck in phase 2. During Phase 2, the winner of the competition cycle, after waiting its t_A (arbitration settling time) time, transitions the cycle to Phase 3. The timer is used to prevent livelock where the winning module may not transition the cycle to Phase 3.

5.5.2.1 Phase 1, Idle Bus Arbitration Events That Cause a Transition to Phase 2

During phase 1 the arbitration controller will output ! IBA_CPT*. When the external logic sees ! IBA_CPT* and the parallel bus is inactive (AS*, AK*, ! AI*) it should drive one of the data bits of the parallel address/data bus.

5.5.3 Phase 2, Competition Phase

This Phase is characterized by AP* asserted and AQ* and AR* released on Futurebus+. See Figure 7c for the DS3875 Arbitration Controller Phase 2 state diagram.

The arbitration controller will be asserting APO, negating AQO and receiving ARI negated. This is the state of the arbitration synchronization lines when the competition phase (2) is in progress.

While in Phase 2 the following actions are performed:

1. AB__RE* is asserted after 30 ns. This allows the arbitration controller to monitor the winning competition number.
2. The FIFO STRobe is now asserted (! FSTR*).

There are two conditions that can cause AQO to be asserted causing a transition to Phase 3:

1. The AQI input being asserted.
2. Competing, arbitration competition settling time (t_a) expired, one μ s Phase 2 arbitration error timer not expired, and the WIN*_GT* input being asserted.

5.5.3.1 Phase 2, Idle Bus Arbitration Events That Cause a Transition to Phase 3

The external logic should drive the IBA Success signal (! IBA_S*) during phase 2 if DI* is released, only this modules data bit is driven on the data bus, and the arbitration settling Time (t_a) has not expired.

When the arbitration controller sees ! IBA_S* asserted it will issue bus grant (! BGRNT*) to give access of the bus to the module that won the IBA. If two or more modules have a request, then normal arbitration will determine which module will gain access.

5.5.4 Phase 3, Error Check Phase

This Phase is characterized by AP* and AQ* asserted AR* released on Futurebus+. See Figure 7d for the DS3875 Arbitration Controller Phase 3 state diagram. Also see Figures 6b, c, d for how AS_CANCEL relates to Phase 3.

The arbitration controller will be asserting APO and AQO, and negating ARO. This is the state of the arbitration synchronization lines when the error check phase (3) is in progress.

While in Phase 3 the following actions are performed:

1. If the module is a competitor and winner of the arbitration, the W(winner) bit in the STATUS register is set.
2. Upon entering phase 3, after 20 ns, AB__RE* is negated.

5.0 Arbitrating for Futurebus+ (Continued)

There are seven conditions that will cause the arbitration controller to negate APO:

1. This module has had a Bus ReQuest (! BRQ*), won IBA, and asserted AC1O and AS.
2. The current master releases AS (! AS_CANCEL). The master has completed its transactions on the parallel bus, see *Figures 6b, c, d*.
3. This module detected the 1 μ s timeout or a parity error occurred during the arbitration cycle. This error condition will cause the assertion of AC0O and AC1O and ERINT* signals which will inhibit the transfer of tenure during this arbitration cycle.
4. Another module has detected that transfer of tenure is to be inhibited (AC1I).
5. This module was competing and won the competition where this is the first pass of a two pass arbitration cycle.
6. This module did not compete (CMPT*) but now has a bus request (! BRQ*) and its competition number is greater than (! WIN*_GT*) the modules competition number that won the current arbitration competition. This module preempts the current arbitration competition by asserting AC1O. This inhibits the transfer of tenure during this arbitration cycle and allows a new arbitration cycle to be initiated in which this module can compete.
7. This module was competing (! CMPT*) and won the competition (W bit of Status register set) but the bus request or message request has been negated (BRQ* or MGRQ*). This error condition will cause the assertion of AC0O, AC1O and ERINT* signals which will inhibit the transfer of tenure during this arbitration cycle.

After all the modules have negated AP*, upon receiving IAPI, the arbitration cycle will transition to **Phase 4**.

5.5.4.1 Phase 3, Idle Bus Arbitration Events That Cause a Transition to Phase 4

During phase 3 of the arbitration cycle, when the current master has not yet released the bus (AS), the new master (a module that was competing (!IBA_CMPT*) and won (!IBA_S*)) will drive AC1O to inhibit the transfer of tenure during the normal bus arbitration cycle (tenure was transferred during the IBA cycle).

Note: The new master will now continue the normal arbitration process to completion but may begin conducting transactions on the bus.

5.5.5 Phase 4, Master Release Phase

This Phase is characterized by AP* released, AQ* asserted, and AR* released on Futurebus+. See *Figure 7e* for the DS3875 Arbitration Controller Phase 4 state diagram and *Figures 6b, c, d* for how AS_CANCEL relates to phase 4.

The arbitration controller will be receiving API negated, asserting AQO and negating ARO. This is the state of the arbitration synchronization lines when the master release phase (4) is in progress.

While in Phase 4 the following actions are performed:

1. All modules, other than the bus master, start a 1 μ s timer. This is referred to as the Master release timer. The master has 1 μ s to complete its transactions or to inhibit the transfer of tenure and proceed to phase 5. This timer is specified in the Futurebus+ specification so in the

event where the current master does not respond, the master elect may assume mastership during phase 5.

2. The CMPT* signal is negated (CMPT*).

There are six conditions that can cause ARO to be asserted causing a transition to **Phase 5**:

1. Transfer of tenure is inhibited indicated by the assertion of AC1I.
2. Was not Master and the ARI input was asserted.
3. Was Master and did not cancel (! AS_CANCEL) the arbitration competition, see *Figures 6b, c, d*.
4. There is no current master (immediately following power up) so the master elect may assert ARO.
5. Was Master and did cancel (! AS_CANCEL) the arbitration competition, see *Figure 6d*. In this case the current master will assert AC1O to inhibit the transfer of tenure during this arbitration cycle.
6. All modules other than the current master detect the Master Release Timeout.

5.5.6 Phase 5, Tenure Transfer Phase

This Phase is characterized by AP* released, AQ* asserted, and AR* asserted on Futurebus+. See *Figure 7f* for the DS3875 Arbitration Controller Phase 5 state diagram.

The arbitration controller will be negating API and asserting AQO and ARO. This is the state of the arbitration synchronization lines when the tenure transfer phase (5) is in progress.

While in Phase 5 the following actions are performed:

1. If IBA_CMPT* signal was asserted, it is now negated (IBA_CMPT*).
2. The unlock signal (! UNLK*) will be asserted if locked (! LKD*) is asserted and the arbitration condition signals (AC0I, AC1I) are negated.
3. This phase will update the following status bits:
 1. The Master status bit (bit 5) in the status register.
 2. The Competitor status bit (bit 4) in the status register.
 3. The WIN status bit (bit 3) in the status register.
 4. The Uniqueness, round robin and priority fields of the RXCN1 register.
 5. The Priority field of the RXCN0 register.

There are four conditions that can cause AQO to be negated:

1. Had a message request (! MGRQ*) and won the competition (! WIN*_GT*). In this case the message transmitted output will also be asserted (! MSGTX*).
2. Competed for the bus (! CMPT*), there were no errors (! AC0I, ! AC1I), and won the competition (! WIN*_GT*). In this case the bus grant output will be asserted (! BGRNT*) and the internal master bit will be set (M, bit 5 in the status register).
3. There were no errors (! AC0I, ! AC1I) and the module is not the winner. Resets the M bit in the status register.
4. A Message was received. In this case either message interrupt will be asserted (! MGINT*) or the powerfail interrupt (! PFINT*) will be asserted.

5.0 Arbitrating for Futurebus+ (Continued)

When a message is received the FIFO strobe (FSTR*) will be negated, strobing a new message into the external FIFO, given the following conditions:

1. The message is not being sent by this module.

2. This is the second pass of an arbitration message.

3. No errors occurred during this arbitration cycle.

4. This is not a powerfail interrupt message (!PFINT*).

Once all the modules have negated AQ*, upon receiving !AQI, the arbitration cycle will transition to Phase 0.

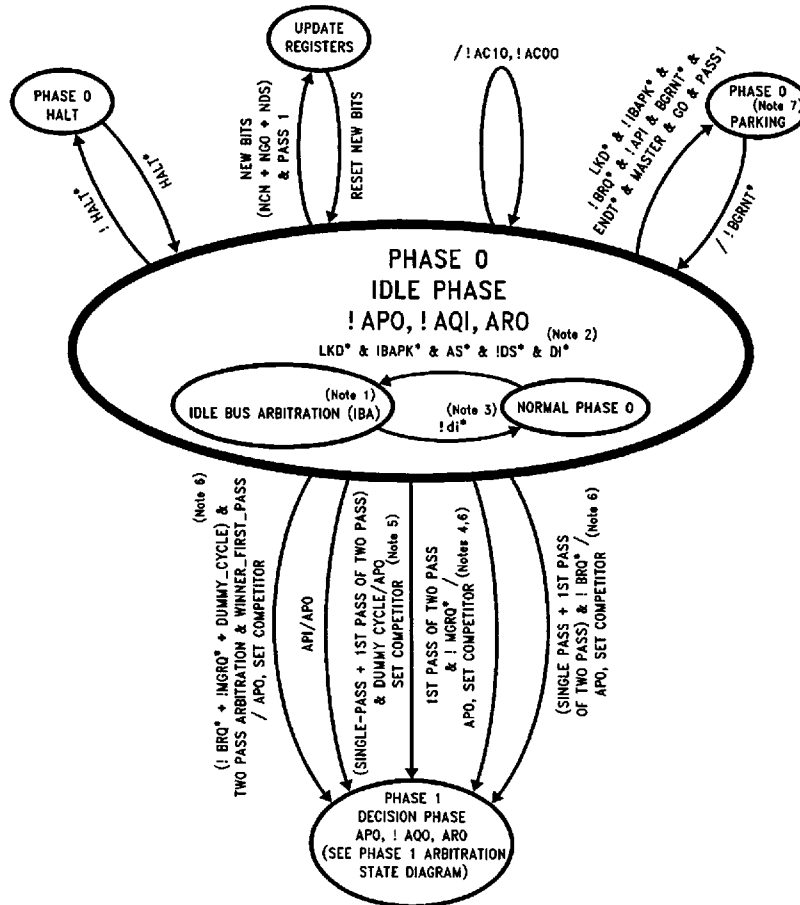

FIGURE 7a. DS3875 Phase 0 Arbitration State Diagram

TL/H/10747-16

Note: **HALT* is assumed to be negated in this state diagram. Also, the arbitration Controller GO bit in CTRL3 register must be asserted for the controller to accept requests. Otherwise this module may not compete but will be a by-stander.

Note 1: Idle Bus Arbitration during Phase 0 is not an internal state of the Arbitration Controller. It is shown in this state diagram only to give a better understanding of Phase 0 arbitration.

Note 2: The Arbitration Controller does not check for LKD*, but it should not be asserted during IBA to be in compliance with the Futurebus+ specification. If lock was asserted during IBA another module could win IBA and try to access this modules locked resources, this would result in deadlock. Also, the Arbitration controller does not check AS* & !DS* & !DI*, this is left up to external logic and this must be the first pass if two pass arbitration has been selected.

Note 3: The output !di* from this module is driven from external control logic, it is only shown in this diagram to allow a clearer understanding of how IBA relates to normal arbitration.

Note 4: Note that message request (MGRQ*) has a higher priority inside the arbitration controller then does bus request (BRQ*).

Note 5: This is a dummy arbitration cycle initiated to unlock (UNLK*) the modules resources. The dummy cycle is initiated, by the current master, if the modules resources are still locked (!LKD*) after end of tenure (ENDT*) has been issued (*BGRNT* & Master & !LKD* & ENDT*) and the arbitration bus is idle.

Note 6: If this is the second pass of a two-pass arbitration cycle and a new request (!BRQ* or !MGRQ*) is generated, that request will not be allowed to compete until the next arbitration cycle. Note that pre-emption is allowed.

Note 7: If Two-Pass arbitration has been selected, Parking is only possible during Phase 0 of the first pass.

5.0 Arbitrating for Futurebus+ (Continued)

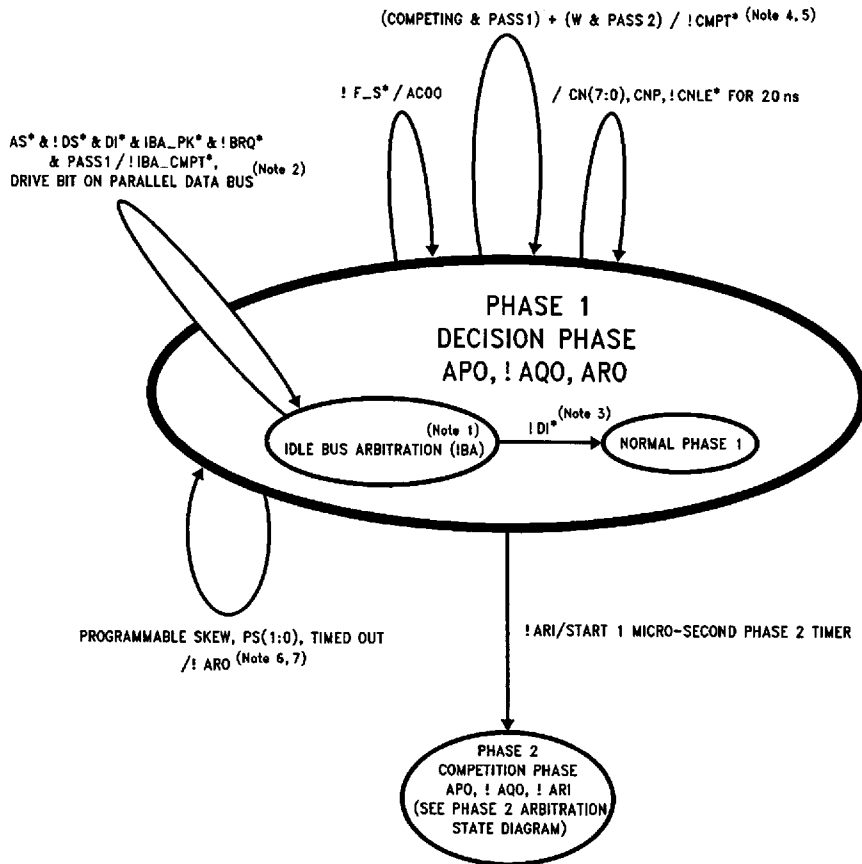

FIGURE 7b. Phase 1 Arbitration State Diagram

TL/H/10747-17

Note 1: Idle Bus Arbitration during Phase 1 is not an internal state of the Arbitration Controller. It is shown in this state diagram only to give a better understanding of Phase 1 arbitration.

Note 2: One bit on the parallel data bus is driven by external logic (the arbitration controller only drives the !IBA_CMPT output) only if IBA is supported by the module. Note that the arbitration controller does not require AS* & !DS* & DI*, external logic will require these conditions (from the Futurebus+ specification).

Note 3: If a module does not want IBA to select a new master external logic around the arbitration controller will drive !di*. This transition is shown in this diagram to allow a clearer understanding of how IBA relates to normal arbitration.

Note 4: Competing = "!BRQ* + !MGRQ* + Dummy Cycle", W = W bit of STATUS register.

Note 5: These Requests must have occurred before APO was asserted or they will not compete until the next arbitration cycle.

Note 6: The possible metastable condition of "!BRQ* + !MGRQ* + Dummy Cycle" occurring at the same time as API* must be resolved before driving !ARO.

Note 7: All conditions shown above the Phase 1 state must be completed before driving !ARO.

5.0 Arbitrating for Futurebus+ (Continued)

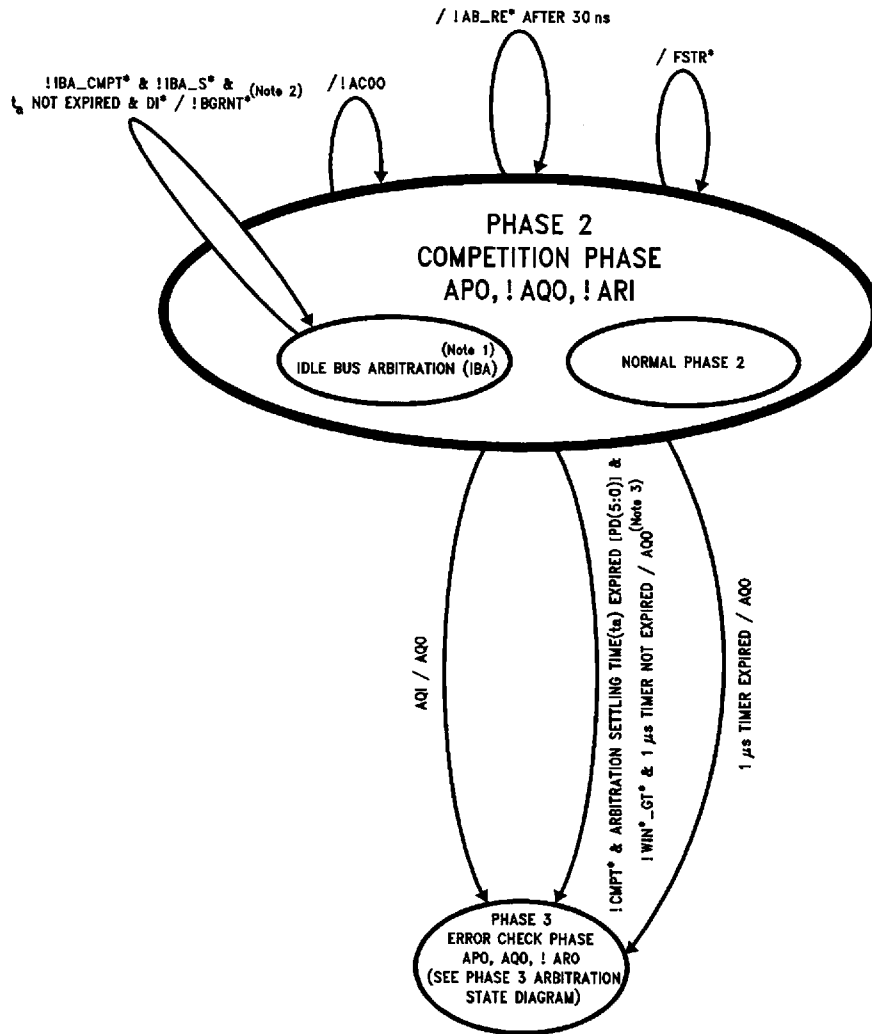

FIGURE 7c. Phase 2 Arbitration State Diagram

TL/H/10747-18

Note 1: Idle Bus Arbitration during Phase 2 is not an internal state of the Arbitration Controller. It is shown in this state diagram only to give a better understanding of Phase 2 arbitration.

Note 2: Bus Grant ($\overline{\text{BGRNT}}^*$) is driven by the arbitration controller during Phase 2 only if IBA was successful for this module and the Arbitration settling time (t_a) has not expired. Also, $\overline{\text{DI}}^*$ is shown here to indicate that IBA is allowed to select a new Master. $\overline{\text{DI}}^*$ is not an Arbitration Controller signal. $\overline{\text{DI}}^*$ is represented here for completeness sake only to give a better understanding. Also, external logic will release the bit on the Parallel data bus.

Note 3: This transition to Phase 3 occurs when this module was competing, its arbitration settling time expired, and the one micro-second Phase 2 error timer has not expired.

5.0 Arbitrating for Futurebus + (Continued)

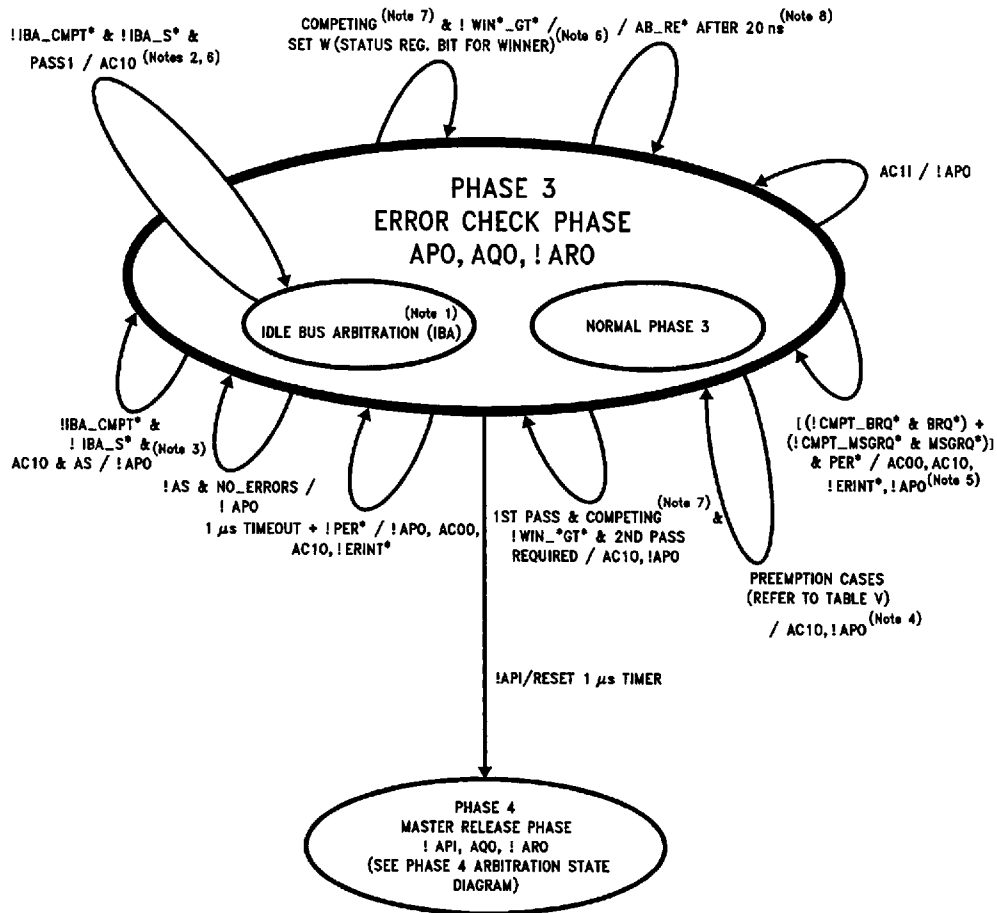

FIGURE 7d. Phase 3 Arbitration State Diagram

TL/H/10747-19

Note 1: Idle Bus Arbitration during Phase 3 is not an internal state of the Arbitration Controller. It is shown in this state diagram only to give a better understanding of Phase 3 arbitration.

Note 2: AC10 is asserted to cancel the transfer of bus tenure if IBA was successful.

Note 3: AS is asserted if IBA was successful for this module.

Note 4: A Module will pre-empt another module if it did not compete in the present competition yet its arbitration number is higher than the current winner. In this instance the pre-emption module will assert AC10 to cancel the transfer of tenure and allow a new competition to take place. Preemption is not allowed in the 1st pass when the arbitration cycle consists of two pass.

Note 5: If a module that competed and won no longer is issuing a bus or message request, AC10 will be driven to cancel the transfer of tenure and !ERINT* will be driven to indicate an error has occurred.

Note 6: AC10 (if IBA was successful) and the W STATUS bit (if competing and won) must be asserted before driving !APO.

Note 7: Competing = !BRQ* + !MGRQ* + Dummy Cycle.

Note 8: All actions in this phase are performed after the arbitration number is latched.

5.0 Arbitrating for Futurebus+ (Continued)

!MASTER/START 1 μ s MASTER RELEASE TIMER

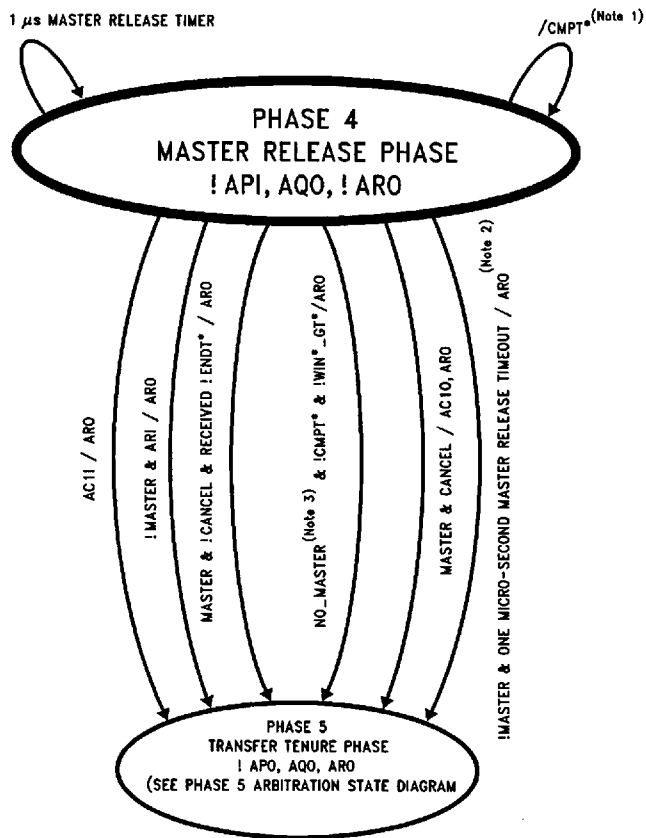

FIGURE 7e. Phase 4 Arbitration State Diagram

TL/H/10747-20

Note 1: The Arbitration controller releases its arbitration number on Futurebus+ by negating CMPT* to the arbitration transceiver.

Note 2: If no master or master error occurred, on timeout, assert ARO so the master elect may take over the bus.

Note 3: No_Master = No Current Master of Futurebus+ during Powerup or Initialization.

5.0 Arbitrating for Futurebus + (Continued)

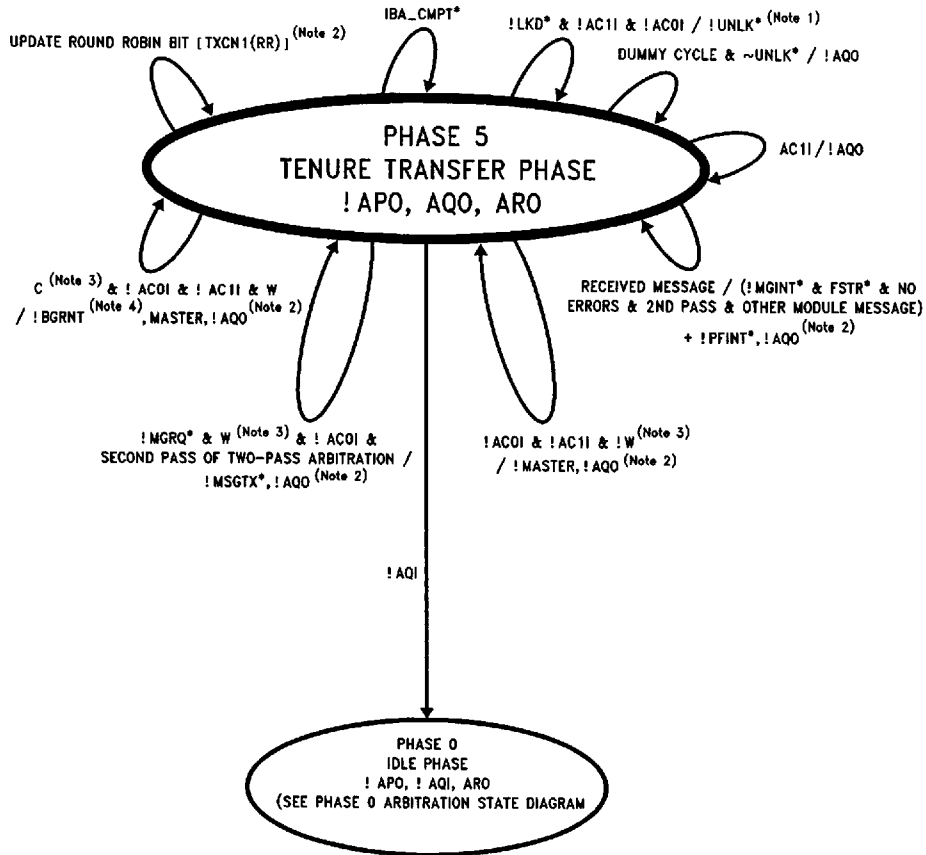

FIGURE 7f. Phase 5 Arbitration State Diagram

TL/H/10747-21

Note 1: Unlock this modules resources if its resources were locked and this is restricted mode, one pass arbitration, or the second pass of a two-pass arbitration cycle.

Note 2: Only update Master status bit, TXCN1 (RR), $!MGINT^*$, $FSTR^*$, $!PFINT^*$, $!BGRNT^*$, or $!MSGTX^*$ given that this is restricted mode, one pass arbitration, or the second pass of a two-pass arbitration cycle.

Note 3: $W = W$ bit in the STATUS register, $C = C$ bit in the STATUS register.

Note 4: $!BGRNT^*$ is not issued if this is a dummy arbitration cycle, initiated by the arbitration controller to unlock resources.

Arbitration Controller Internal Register Bit Changes

**TABLE III. Restricted Mode Arbitration or Unrestricted Mode Arbitration
(One Pass, or Second Pass of Two Pass)**

Modules Category during Arbitration	TXCN1 RR	STATE All Bits (Note 1)	STATUS			RXCN0 All Bits	RXCN1 (Note 2)				RXMSG A(0:7)	CLRERI Reset, Set	CLRMGI CLRPF1 Reset, Set
			W	C	M		U(0:4)	RR	PO	P1			
Competitor	5	X	1, 2	0, 1	5		3	3	3	3	3	X, 4	X, 5
By-Stander	5	X	1	0	5		3	3	3	3	3	X, 4	X, 5
Sending Message		X	1, 2	0, 1							3	X, 4	X, 5
Receiving Message		X	1	0, 1							3	X, 4	X, 5
Pre-Emption		X					3	3	3	3			
IBA	5 (Note 4)	X			5 (Note 5)		3	3	3	3	3	X, 4	X, 5
Parking (Note 3)													

Note: The number shown within the box defines the arbitration phase where the particular bit may change state.

Note 1: Note that the STATE Register is updated in each Phase of Arbitration.

Note 2: This is the new Masters Competition Number.

Note 3: Parking is only a Phase 0 event.

Note 4: The RR bit is only updated on the New Master.

Note 5: The M bit is updated if IBA succeeded during Restricted Mode, or Unrestricted Mode (One Pass or the First Pass of Two Pass Arbitration).

"X" means that any Phase can update this bit (or bits).

"." is used in the table to depict the condition where a particular Status bit is Reset and where it is Set (Ex. 0, 1 means that this Status bit is Reset in Phase 0 and Set in Phase 1).

"-" is used in the table to depict the condition where a particular Status bit may change within several sequential phases (Ex. 2-4 means that this Status bit can change in Phases 2, 3, or 4).

TABLE IV. Unrestricted Mode, First Pass of Two Pass Arbitration

Modules Category during Arbitration	TXCN1 RR	State All Bits (Note 1)	Status			RXCN0 All Bits (Note 2)	RXCN1				RXMSG A(0:7)	CLRERI Reset, Set	CLRMGI CLRPF1 Reset, Set
			W	C	M		U(0:4)	RR	PO	P1			
Competitor		X	1, 2	0, 1		3						X, 4	X, 5
By-Stander		X	1	0		3						X, 4	X, 5
Sending Message		X	1, 2	0, 1								X, 4	X, 5
Receiving Message		X	1	0, 1								X, 4	X, 5
Pre-emption		X				3							
IBA		X			5	3						X, 4	X, 5
Parking (Note 3)													

Note: The Number shown within the box defines the arbitration phase where the particular bit may change state.

Note 1: Note that the STATE Register is updated in each Phase of Arbitration.

Note 2: This is the new Masters Competition Number.

Note 3: Parking is only a Phase 0 event.

Note: "X" means that any Phase can update this bit (or bits).

Note: "." is used in the table to depict the condition where a particular Status bit is Reset and where it is Set (Ex. 0, 1 means that this Status bit is Reset in Phase 0 and Set in Phase 1).

Note: "-" is used in the table to depict the condition where a particular Status bit may change within several sequential phases (Ex. 2-4 means that this Status bit can change in Phases 2, 3, or 4).

TABLE V. Pre-emption

Category	Pre-emption Case	Result
Messages	message vs message	no pre-emption
	message vs anything else	pre-empt: no number comparison
	anything vs message	no pre-emption
Restricted Mode	restricted vs restricted	pre-empt if: TXCN1 > RXCN1
	restricted vs message	no pre-emption
Unrestricted Mode	1 pass vs 2 pass	pre-empt: no number comparison
	1 pass vs 1 pass	pre-empt if: TXCN1 > RXCN1
	2 pass vs 2 pass	pre-empt if: TXCN0 > RXCN0 and TXCN1 > RXCN1

Note: All pre-emptons take place in the second pass of arbitration or the only pass of arbitration.

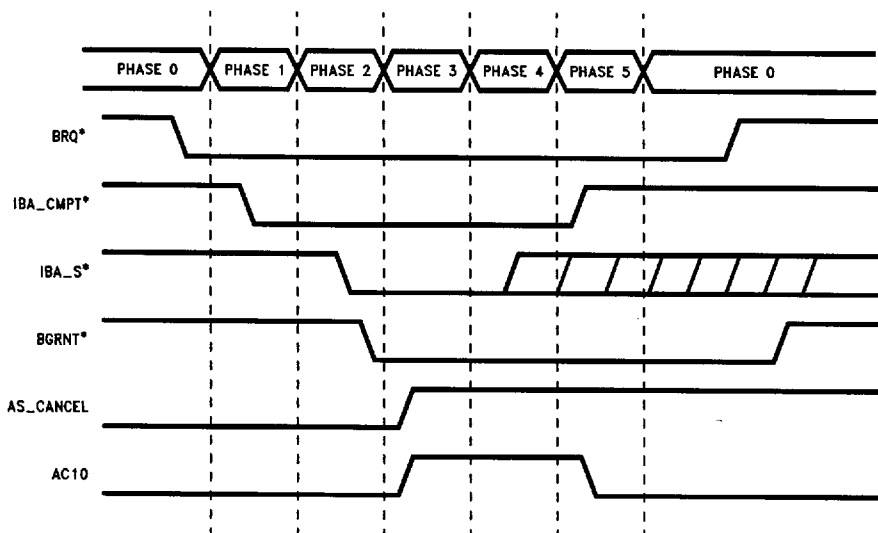

FIGURE 12a. IBA—Restricted or Unrestricted Single Pass

TL/H/10747-29

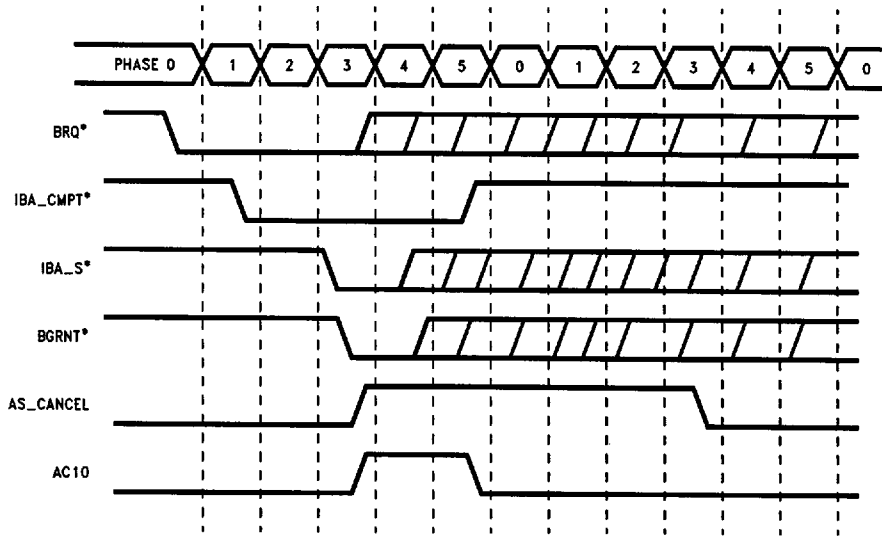

FIGURE 12b. IBA—Unrestricted Two Pass

TL/H/10747-30

6.0 The DS3875 Arbitration Controller Support of Locking and Unlocking

The DS3875 Arbitration Controller supports locking and unlocking of the modules resources whether it is a master or a slave (see *Figure 8*).

If the Module becomes master and wishes to lock the slave's resources, it should assert LKD* (! LKD*) after receiving bus grant (! BGRNT* from the arbitration controller), and drive the appropriate lock command during the parallel bus connection phase. This lock command (during the connection phase of the parallel bus) will cause the selected slave module(s) to assert lock (! LKD*) to their arbitration controller. Once the module has finished its parallel bus transactions it will assert end of tenure (! ENDT*).

If the Master is in, or enters, Phase 0:

1. with end of tenure issued,
2. no other module has started an arbitration competition,
3. LKD* is still asserted,
4. a new bus request (! BRQ*) has not been issued

it will start a dummy arbitration competition cycle to unlock all resources on the bus that were locked. The dummy cycle will proceed through the normal arbitration competition except that no bus grant will be asserted if the module wins the arbitration competition.

If another module has initiated an arbitration competition the master will participate in the competition and no dummy cycle will be initiated.

During Phase 5, upon successful completion of the arbitration cycle unlock will be asserted (! UNLK*) until the lock input is negated.

A. Master Module Lock and Unlock Timing Diagram

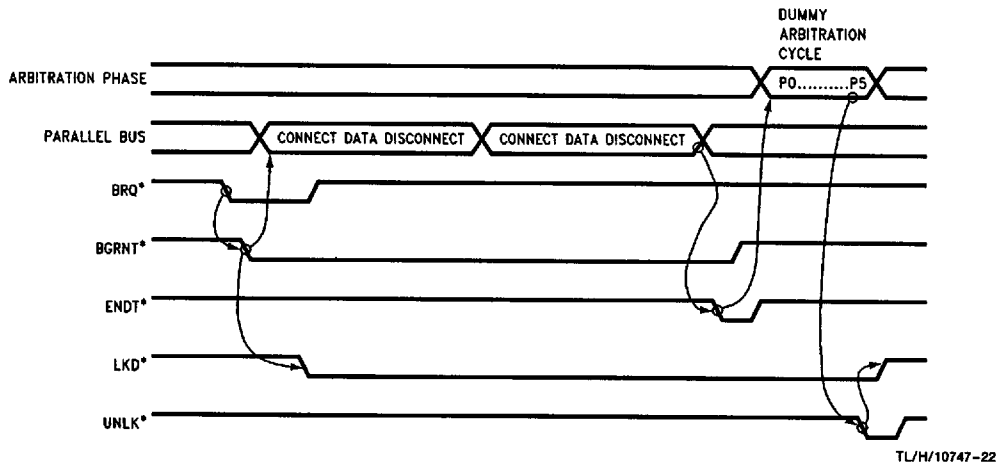

B. Slave Module Lock and Unlock Timing Diagram

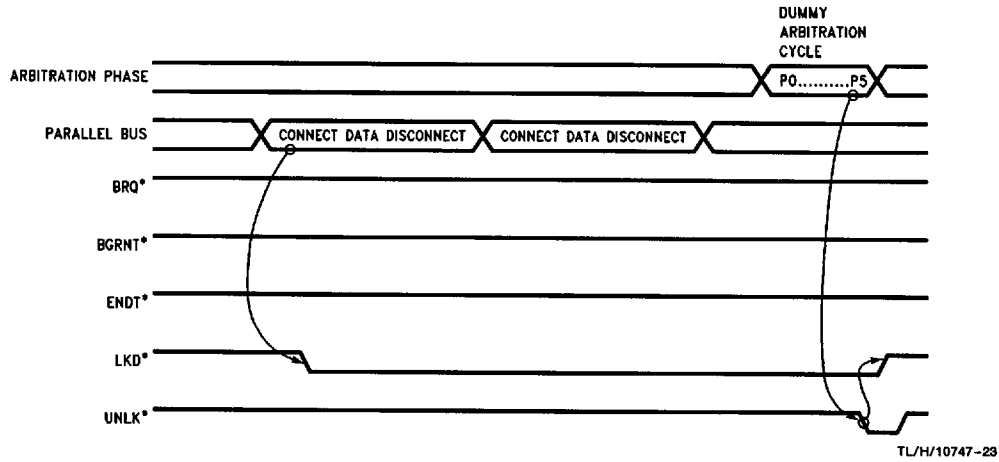

FIGURE 8. Master and Slave Lock and Unlock Timing Diagrams

7.0 Register Description

TOTAL MEMORY MAP

ADDRESSABLE REGISTERS

0000	TXCNO 7	(R/W) 0
0001	TXCN1 7	(R/W) 0
0010	TXMSG 7	(R/W) 0
0011	CTRL1 7	(R/W) 0
0100	CTRL2 7	(R/W) 0
0101	CTRL3 7	(R/W) 0
0110	STATE 7	(R) 0
0111	STATUS 7	(R) 0
1000	RXCNO 7	(R/W) 0
1001	RXCN1 7	(R/W) 0
1010	RXMSG 7	(R/W) 0
1011	CLRERI 7	(R/W) 0
1100	CLRMGI 7	(R/W) 0
1101	CLRPFI 7	(R/W) 0
1110	Reserved	
1111	REV NO. 7	(R) 0

HARDWIRED REGISTER

ALL 1s	0
8	0

Legend:

Register Type	
Register Address	Register_Name (Read/Write)
ADD(3:0)	MSB LSB

7.0 Register Description (Continued)

This section describes the addressable registers and the ALL1s hardwired register.

7.1 ALL1S

This register carries the first word of an arbitration message (h'1ff).

7.2 TXCN0 (ADD(3:0) = 0000)

For the Unrestricted Mode, this register stores the pass 1 arbitration number of a two pass arbitration. (CN7 = 0). Defaults to h'00.

7	6	5	4	3	2	1	0
0	P7	P6	P5	P4	P3	P2	P1

Bit	Symbol	Description
0-6	P(1:7)	Priority field of the arbitration number.
7	0	This bit is fixed at zero as specified in the Futurebus+ specification for the pass 1 number of a two pass arbitration.

Note: The Parity bit CNp for the arbitration number is internally generated during the time the host writes the numbers into the controller. The odd parity as specified in the Futurebus+ specifications is generated. CNp is set to one when even number of ones are present in the arbitration number.

7.3 TXCN1 (ADD(3:0) = 0001)

For the Unrestricted Mode, this register stores the pass 2 arbitration number of a two pass arbitration, or stores the single pass arbitration number (CN7 = 1). This register also stores the arbitration number used in the Restricted Mode. Defaults to h'80.

7	6	5	4	3	2	1	0
1/P1	P0	RR	U4	U3	U2	U1	U0

Bit	Symbol	Description
0-4	U(0:4)	Uniqueness field of the arbitration number.
5	RR	Round Robin bit of the arbitration number. Note: This bit is updated during phase 5, upon the successful transfer of tenure. See Table III.
6	P0	Priority field of the arbitration number. If configured as a two pass arbitor, P0 is part of P(0:7). If configured as a single pass arbitor, P0 is the priority field. If configured to arbitrate in restricted mode then P0 is part of P(0:1).
7	1/P1	This bit is fixed at one as specified in the spec for the pass 2 number of a two pass arbitration, and for the single pass arbitration number. This bit is P1 for the restricted mode arbitration number.

Note: The Parity bit CNp for the arbitration number is internally generated during the time the host writes the numbers into the controller. The odd parity as specified in the Futurebus+ specifications is generated. CNp is set to one when even number of ones are present in the arbitration number.

7.0 Register Description (Continued)

7.4 TXMSG (ADD(3:0) = 0010)

This register holds the arbitration message to be transmitted. Defaults to h'ff (Powerfail).

7	6	5	4	3	2	1	0
A7	A6	A5	A4	A3	A2	A1	A0

Bit	Symbol	Description
0-7	A(0:7)	Arbitration message to be sent.

Note: The Parity bit CNp for the arbitration number is internally generated during the time the host writes the numbers into the controller. The odd parity as specified in the Futurebus+ specifications is generated. CNp is set to one when even number of ones are present in the arbitration number.

7.5 CTRL1 (ADD(3:0) = 0011)

Control register 1. PS(1:0) programs the delay needed to ensure the assertion of the most significant 1 in CN(7:0) after compete is issued before the release of ar*, or, during IBA, this delay ensures there is sufficient time to assert the AD/DATA lines before the release of ar*. PC(5:0) programs the internal divider to receive a clock input from 2 MHz to 40 MHz in steps of 1 Mz. During chip reset, (RST*) the divider is set to receive a clock of 20 MHz. This input clock divider should be programmed during initialization for the desired frequency. Defaults to h'14.

7	6	5	4	3	2	1	0
PS1	PS0	PC5	PC4	PC3	PC2	PC1	PC0

Bit	Symbol	Description															
0-5	PC0-PC5	<p>Programs the internal input clock divider to receive a clock from 2 MHz to 40 MHz, in steps of 1 MHz.</p> <p>The binary value of the clock frequency is coded with PC5 being the MSB. For example, to program the divider to receive a 25 MHz signal PC5:PC0 bits are: 011001. To program the divider to receive a 10 MHz signal PC5:PC0 bits are: 001010.</p>															
6-7	PS0-PS1	<p>Programs the chip to chip skew when releasing AR* in phase 1.</p> <table border="1"> <thead> <tr> <th>PS0</th> <th>PS1</th> <th>DELAY</th> </tr> </thead> <tbody> <tr> <td>0</td> <td>0</td> <td>0 ns</td> </tr> <tr> <td>0</td> <td>1</td> <td>5 ns</td> </tr> <tr> <td>1</td> <td>0</td> <td>15 ns</td> </tr> <tr> <td>1</td> <td>1</td> <td>25 ns</td> </tr> </tbody> </table> <p>This delay ensures that after compete is issued to the transceiver sufficient time is allowed for the number to be put on the bus before releasing AR*. It also provides a means to provide sufficient time for asserting AD/DATA lines during IBA before the release of ar*.</p>	PS0	PS1	DELAY	0	0	0 ns	0	1	5 ns	1	0	15 ns	1	1	25 ns
PS0	PS1	DELAY															
0	0	0 ns															
0	1	5 ns															
1	0	15 ns															
1	1	25 ns															

7.0 Register Description (Continued)

7.6 CTRL2 (ADD(3:0) = 0100)

Control register 2. This register stores two parameters FS_(Fast/Slow) and DS_(Restricted/Unrestricted) that configure the controller to operate in the chosen mode. PD(5:3) selects one of eight delays for the fast module and PD(2:0) selects one of eight delays for the slow module. Defaults to h'00.

	7	6	5	4	3	2	1	0
	F_S*	R_U*	PD5	PD4	PD3	PD2	PD1	PD0

Bit	Symbol	Description																																				
0-5	PD0-PD5	<p>Programs the arbitration delay that is timed in a competition. These bits give a total of 16 selectable delays, 8 fast and 8 slow. PD0-PD2 select the slow module's delay and PD3-PD5 select the fast module's delay.</p> <table style="margin-left: auto; margin-right: auto; border-collapse: collapse;"> <tr> <td style="text-align: center;">(PD5 PD4 PD3)</td> <td style="text-align: center;">Fast</td> <td style="text-align: center;">(PD2 PD1 PD0)</td> <td style="text-align: center;">Slow</td> </tr> <tr> <td style="text-align: center;">000</td> <td style="text-align: center;">100</td> <td style="text-align: center;">000</td> <td style="text-align: center;">125</td> </tr> <tr> <td style="text-align: center;">001</td> <td style="text-align: center;">120</td> <td style="text-align: center;">001</td> <td style="text-align: center;">165</td> </tr> <tr> <td style="text-align: center;">010</td> <td style="text-align: center;">145</td> <td style="text-align: center;">010</td> <td style="text-align: center;">210</td> </tr> <tr> <td style="text-align: center;">011</td> <td style="text-align: center;">165</td> <td style="text-align: center;">011</td> <td style="text-align: center;">255</td> </tr> <tr> <td style="text-align: center;">100</td> <td style="text-align: center;">190</td> <td style="text-align: center;">100</td> <td style="text-align: center;">300</td> </tr> <tr> <td style="text-align: center;">101</td> <td style="text-align: center;">210</td> <td style="text-align: center;">101</td> <td style="text-align: center;">345</td> </tr> <tr> <td style="text-align: center;">110</td> <td style="text-align: center;">235</td> <td style="text-align: center;">110</td> <td style="text-align: center;">385</td> </tr> <tr> <td style="text-align: center;">111</td> <td style="text-align: center;">255</td> <td style="text-align: center;">111</td> <td style="text-align: center;">430</td> </tr> </table>	(PD5 PD4 PD3)	Fast	(PD2 PD1 PD0)	Slow	000	100	000	125	001	120	001	165	010	145	010	210	011	165	011	255	100	190	100	300	101	210	101	345	110	235	110	385	111	255	111	430
(PD5 PD4 PD3)	Fast	(PD2 PD1 PD0)	Slow																																			
000	100	000	125																																			
001	120	001	165																																			
010	145	010	210																																			
011	165	011	255																																			
100	190	100	300																																			
101	210	101	345																																			
110	235	110	385																																			
111	255	111	430																																			
6	R_U*	<p>R_U* Restricted/Unrestricted:</p> <p>0 Configures the controller to arbitrate in unrestricted mode.</p> <p>1 Configures the controller to arbitrate in restricted mode.</p>																																				
7	F_S*	<p>F_S* Fast/Slow:</p> <p>0 Configures the controller as a slow module.</p> <p>1 Configures the controller as a fast module.</p>																																				

7.7 CTRL3 (ADD(3:0) = 0101)

Defaults to h'00.

	7	6	5	4	3	2	1	0
		TCSEL	IBA_PK*	NCN	ND_S*	NGO	D_S*	GO

Bit	Symbol	Description
0	GO	<p>GO Bit:</p> <p>1 indicates that all the required initialization is complete and the controller may accept requests.</p> <p>0 the controller will follow the normal flow of arbitration along with other modules (bystander).</p>
1	D_S*	<p>D_S* Double/Single</p> <p>0 Configures the controller to arbitrate in a single pass arbitration mode.</p> <p>1 Configures the controller to arbitrate in a two pass arbitration mode.</p>
2	NGO	A "one" indicates that a new GO bit has been loaded. This bit is reset automatically when the new GO bit takes effect. To be set by the user when the GO bit is changed.
3	ND_S*	A "one" indicates that a new D_S* bit has been loaded. This bit is reset automatically when the new D_S* bit takes effect. To be set by the user when the D_S* bit is changed.
4	NCN	A "one" indicates that a new CN has been loaded. This bit is reset automatically when the new CN takes effect. This bit is set internally when TXCN1 is accessed while the GO bit is set.
5	IBA_PK*	<p>Idle Bus Arbitration/Parking:</p> <p>1 Configures the controller to do Idle Bus Arbitration.</p> <p>0 Configures the controller to do Parking.</p>
6	TCSEL	A "one" indicates that a test clock is being fed through the CLK pin to test the timers and counters in the controller.

7.0 Register Description (Continued)

7.8 STATE (ADD(3:0) = 0110)

This register contains the present state of the arbitration controller. This information may be used for testing and debugging purposes. Defaults to h'01.

7	6	5	4	3	2	1	0
		ST5	ST4	ST3	ST2	ST1	ST0

Bit	Symbol	Description
0-5	ST(0:5)	These bits indicate the current phase of the arbitration controller.

7.9 STATUS (ADD(3:0) = 0111)

This register contains status information and internal counter/divider test bits. The M, C, W bits default to zero. The counter test bits may be evaluated when feeding in a test clock.

7	6	5	4	3	2	1	0
M	C	W	CT2	CT1	CT0		

Bit	Symbol	Description
2-4	CT(0:2)	Counter test bits: CT2—set to one when 1 μ s timeout occurs. CT1—set to one when divide by 40 divider has divided 40 times. CT0—set to one when divide by n divider has divided n times.
5	W	Win attribute of the module. A "one" indicates that the module is the winner of the current arbitration cycle/pass.
6	C	Competitor attribute of the module. A "one" indicates that the module is competing for the bus.
7	M	Master attribute of the module. A "one" indicates that the module is the current master of the bus.

7.10 RXCNO (ADD(3:0) = 1000)

This register stores the received pass 1 arbitration number of a two pass number (CN = 0). Defaults to h'00.

7	6	5	4	3	2	1	0
0	P7	P6	P5	P4	P3	P2	P1

Bit	Symbol	Description
0-6	P(1:7)	Priority field of the current master/master elect arbitration number. This register is used only if the controller is configured to arbitrate in Unrestricted two pass mode.
7	0	This field is fixed at zero as specified in the Futurebus+ spec for the pass 1 number of a two pass arbitration.

7.0 Register Description (Continued)

7.11 RXCN1 (ADD(3:0) = 1001)

This register stores the received pass 2 arbitration number of a two pass arbitration number, or the single pass arbitration number, (CN7 = 1) in the Unrestricted mode. Also this register stores the Restricted Mode arbitration number. Defaults to h'80.

7	6	5	4	3	2	1	0
1/P1	P0	RR	U4	U3	U2	U1	U0

Bit	Symbol	Description
0-4	U(0:4)	Uniqueness field of the current master/master elect.
5	RR	Round Robin bit of the current master/master elect.
6	P0	Priority field of the current master/master elect. If configured as a two pass arbitor, P0 is part of P(0:7). If configured as a single pass arbitor, P0 is the priority field. If configured to arbitrate in restricted mode then P0 is part of P(0:1).
7	1/P1	This field is fixed at one as specified in the spec for the pass 2 number of a two pass arbitration, and for the single pass arbitration number. This bit is P1 for the restricted mode arbitration number of the current master/master elect.

7.12 RXMSG (ADD(3:0) = 1010)

This register stores the received non-powerfail arbitration message. Defaults to h'00.

7	6	5	4	3	2	1	0
A7	A6	A5	A4	A3	A2	A1	A0

Bit	Symbol	Description
0-7	A(0:7)	Non-powerfail arbitration message received from another module.

7.13 CLRERI (ADD(3:0) = 1011)

Error bits to indicate Parity, no BRQ/MGRQ or a timeout error. A dummy write into this register clears the error interrupt and all the error bits. Defaults to h'00.

7	6	5	4	3	2	1	0
ER3	ER2	ER1					

Bit	Symbol	Description
7	ER3	Error bit 3: indicates to the winner of the arbitration cycle that BRQ/MGRQ signal is no longer present.
6	ER2	Error bit 2: indicates a timeout error.
5	ER1	Error bit 1: indicates a Parity error.

7.14 CLRMGI (ADD(3:0) = 1100)

7.15 CLRPMI (ADD(3:0) = 1101)

A dummy write into these registers clears the respective interrupt.

7	6	5	4	3	2	1	0

Bit	Symbol	Description
0-7		

7.0 Register Description (Continued)

7.16 REV NO. (ADD(3:0) = 1111)

Revision number of the controller.

7	6	5	4	3	2	1	0
R7	R6	R5	R4	R3	R2	R1	R0
Bit	Symbol	Description					
0-7	R(0:7)	REV NO.					

8.0 Programming Registers

During power up, the registers should be initially programmed. The host may read/write to/from the register block at any time. The host may select to write data into the register either on the falling edge of DSACK* or on the rising edge of CS*. A zero on the SEL input pin configures the controller to latch in data on the falling edge of DSACK* while a one sets the controller to latch in data on the rising edge of CS*. Refer to the timing diagrams (see Figures T2a, b, c).

8.1 HOST WRITE CYCLE USING FALLING EDGE OF DSACK* (Figure T2A)

1. R_W* signal is negated.
ADD(3:0) contains the address of the register to be accessed. (Note: The setup time with respect to CS* must be satisfied.)
2. CS* is asserted (! CS*).
3. When the proper setup time of CS* to the rising edge of clock is met and CS* is low for at least 3 clock cycles, then DATA(7:0) will be latched into the register, by the falling edge of DSACK*, on the 3rd rising clock edge after the assertion of CS*. If the CS* setup time is not met and CS* is low for at least 3 clock cycles, then DSACK* is asserted and the data (DATA(7:0)) is latched into the arbitration register on the following 3rd or 4th rising clock edge after the assertion of CS*. If CS* is negated (CS*) before 3 clock cycles, then DSACK* is not generated and as a default, DATA (7:0) is latched into the arbitration controller register on the rising edge of CS*.
4. Host negates CS*.
5. Arbitration Controller negates DSACK* (DSACK*) if it was asserted.

8.2 HOST WRITE CYCLE USING RISING EDGE OF CS* (Figure T2b)

1. R_W* signal is negated.
ADD(3:0) contains the address of the register to be accessed. (Note: The setup time with respect to CS* must be satisfied.)
2. CS* is asserted (! CS*).
3. DSACK* is asserted (! DSACK*) by the Arbitration Controller when CS* is asserted for at least three clock cycles. If CS* is negated (CS*) before three clock cycles, DSACK* is not asserted. The DSACK* signal may be used or ignored by the system designer, in this case.
4. Host negates CS*. DATA (7:0) which satisfied the setup time to the rising edge of CS* is latched into the arbitration controller register.
5. Arbitration Controller negates DSACK* (DSACK*) if it was asserted.

8.3 HOST READ CYCLE (Figure T2c)

1. R_W* signal is set high.
ADD (3:0) contains the address of the register to be accessed. (Note: The setup time with respect to CS* must be satisfied.)
2. CS* is asserted (! CS*).
3. The data will be available on the DATA (7:0) bus within the access time specified in the AC timing section.
4. The Data Strobe ACKnowledge (DSACK*) signal is generated as an acknowledge to the host signifying the validity of the accessed data. DSACK* may be used to insert WAIT states to the host during a host read cycle. When the proper setup time of CS* to the rising edge of clock is met and CS* is low for at least three clock cycles, DSACK* is asserted (! DSACK*) on the 3rd rising clock edge after the assertion of CS*. If the CS* setup time was not met and CS* is low for at least three clock cycles, then DSACK* is asserted on the following 3rd or 4th rising clock edge after the assertion of CS*. If CS* is not low for at least 3 clock cycles, DSACK* is not generated.
5. Host reads data and negates CS* (CS*).
6. Arbitration Controller negates DSACK* (DSACK*) if it was asserted.

9.0 Clock/Timer/Delay Lines

(See Figure 9.) The input clock signal (CLK) to the arbitration controller is assumed to be a clock from 2 MHz to 40 MHz, in steps of 1 MHz.

The clock signal is also used for synchronization purposes during read or write transfers. This is accomplished by synchronizing the DSACK* (Data Strobe Acknowledge) output from the Arbitration Controller to the clock during arbitration controller register reads or writes.

The binary value of the input clock (CLK) frequency is loaded into the CTRL1 [5:0] register. This value is used to program the divide by n counter to scale the input clock down to a 1 MHz clock internally. The PLL ring oscillator also has a clock divider (divide by 40) to scale it down to a 1 MHz clock. These two clocks are compared and the difference between the two clocks is fed back to the ring oscillator to cause it to lock onto the appropriate frequency.

The PLL is used to generate several programmable delay lines and the 1 μs Timer used during phase 2 and phase 4. The 1 μs timer, divide by 40 divider and divide by n divider can be tested to determine proper functionality. Refer to Testing the Arbitration Controller and Register Description sections for details.

9.0 Clock/Timer/Delay Lines (Continued)

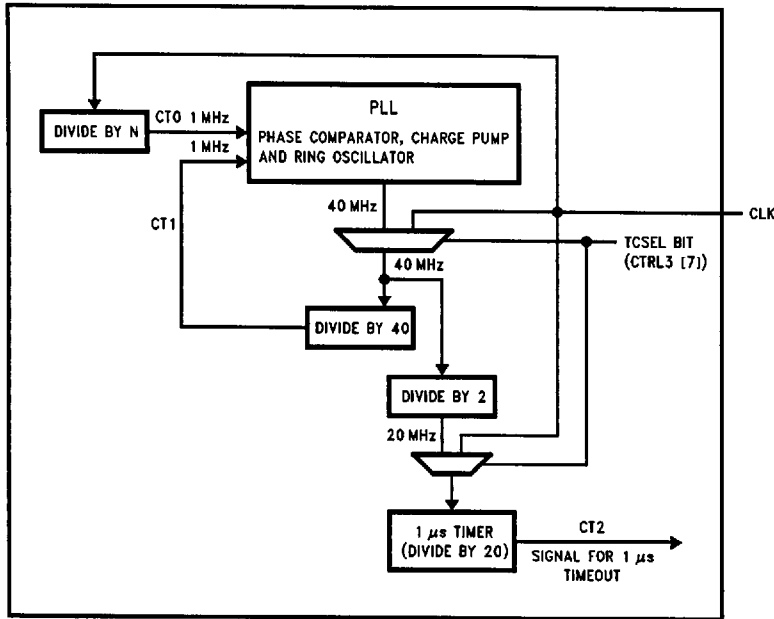

FIGURE 9. PLL, Timer and Test Circuitry

TL/H/10747-24

10.0 Reset/Initialization/Power Up

Two distinct input reset pins are available on the Arbitration Controller, RINT* (Bus Reset and Initialization) and RST* (Power Up Reset). These signals are activated by the module upon detecting either RE* (in an appropriate condition) on Futurebus+ or reset from the host or the Protocol Controller. Both these signals are asynchronous inputs so that the reset function is performed immediately after the signal is asserted.

RINT* may be asserted by external logic from RE* being asserted for at least 2 ms or some other appropriate condition. When RINT* is asserted (! RINT*):

1. the arbitration controller is placed in phase 0
2. all outputs of the arbitration controller are negated, except ARO
3. The following registers are cleared: RXCN0, RXCN1, RXMSG, CLRERI, CLRMGI, CLRPFI, and M C W bits of the STATUS register
4. ST0 bit is set in the STATE register

5. Contents of other registers remain, except for the round robin (RR) bit of TXCN1 which is reset.

The rising edge of RINT* will release the arbiter from phase 0. This reset signal should be used during Futurebus+ initialization.

When RST* is asserted (! RST*):

1. all outputs of the arbitration controller are negated
2. the registers are set to default values as given in the register description, Section 7.

The rising edge of RST* will cause ARO to be asserted causing the arbiter to be in phase 0. This reset signal should be used during power-up and live withdrawal.

Figure 10 illustrates how the reset and initialization signals may be used during power up. While powering up, when RINT* is asserted for 100 ms–200 ms, the registers may be programmed. BRQ* should not be issued until after 10 ms after the register CTRL1 is programmed giving the PLL a sufficient time to lock onto the CLK signal.

10.0 Reset/Initialization/Power Up (Continued)

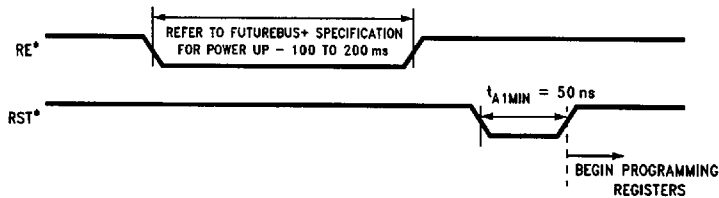

FIGURE 10a. Programming Registers: After Power-Up

TL/H/10747-25

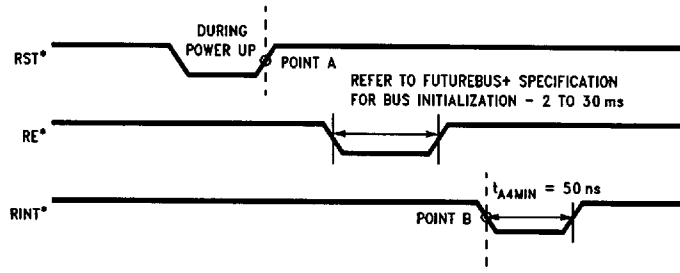

FIGURE 10b. Programming Registers: During Bus Initialization

TL/H/10747-26

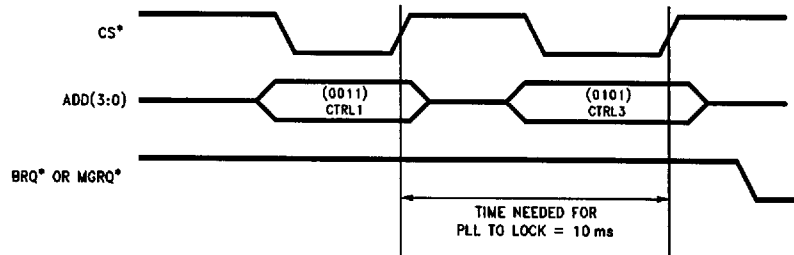

FIGURE 10c. PLL Lock Period

TL/H/10747-27

11.0 Live Insertion

The arbitration Controller supports live insertion (see Figure 11). When a module is being live inserted into an active Futurebus+ system it will be powered up and reset. The live inserted module will reset its arbitration controller with the RST* input and will drive re* on the Futurebus+ backplane.

RE* asserted will cause all active Futurebus+ modules to release their bus lines to prepare for live insertion to the Futurebus+ backplane.

When all the active Futurebus+ modules detect RE* asserted, they should assert HALT* to their arbitration controller and limit the current parallel bus transaction to 128 μ s. The active modules will then remain in Phase 0, upon completion of the current control acquisition cycle, until HALT* is negated.

When the live inserted module detects both:

1. the Parallel bus in the Idle state (AS* and AKf negated),
2. the arbitration bus lines in Phase 0

for 1 μ s then it should assert ai* (protocol controller) and negate the RST* input. The arbitration controller will assert ARO upon detecting the negation of RST*. These actions will complete the Futurebus+ alignment. The live inserted module will then be in arbitration Phase 0; thus, aligned with the other live modules. Then the live inserted module will negate re*.

When the active modules detect the negation of RE* they negate the HALT* input to their arbitration controllers, thus allowing arbitration competition to proceed.

At this point, the live inserted module can only participate as a by-stander during the arbitration competition cycle until it is programmed and 10 ms has elapsed (PLL lock on time). Once the 10 ms has elapsed the module can enable arbitration competition by setting the GO bit in CTRL3. At this time bus requests (BRQ*, MGRQ*) can be accepted to join competition for the parallel bus.

11.0 Live Insertion (Continued)

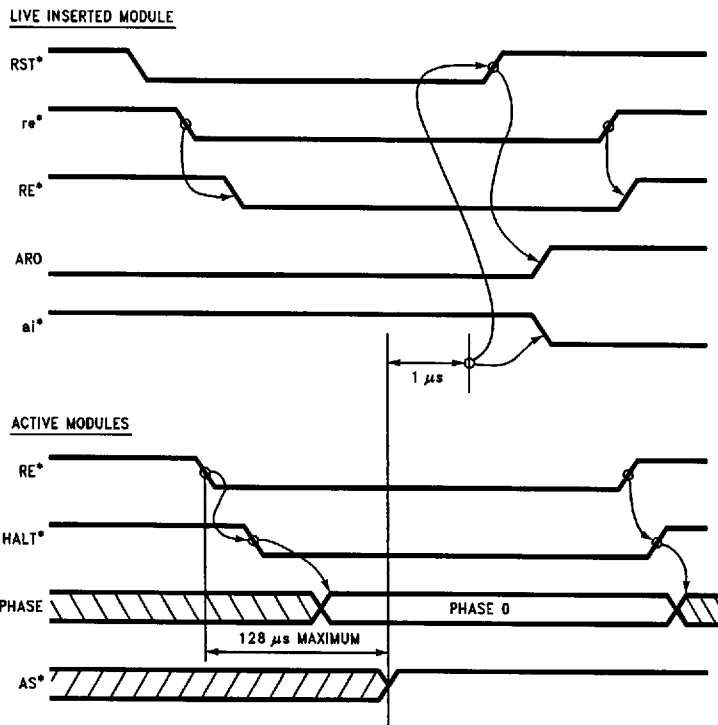

FIGURE 11. Live Insertion

TL/H/10747-28

12.0 Live Withdrawal

When a module is notified to be live withdrawal it will:

1. complete any tasks currently in progress
2. inhibit itself from participating in any more bus transactions (becomes a by-stander)

The module can withdraw from the arbitration protocol in one of three phases:

1. During phase 0 by negating ARO
2. During phase 2 by negating APO
3. During phase 4 by negating AQO

This may be achieved in the DS3875 by issuing the HALT* signal, then when it is observed that the arbitration controller is in Phase 0, asserting the RST* signal to cause all outputs of the arbitration bus to be released. The module may then be withdrawn from the Futurebus+ system.

13.0 Testing the DS3875

The Arbitration Controller has features designed in which ease the testing and monitoring tasks for the user. Registers may be read to determine proper functionality of the chip. For instance, while the Arbitration Controller is operat-

ing, the arbitration phase can be monitored by reading the state register. Also to check proper operation of the 1 μs timer, divide by n divider, and divide by 40 divider, the TCSEL bit in CTRL3 register can be set so that a test clock may be used. This will allow the clock signal to be applied to the circuitry, thus disabling the internally generated signals that are used during normal operation. See Figure 10. To determine the status of the timer and dividers, the status register CT(0:2) bits can be read.

If the user wants to check the proper operation of the CN port:

1. An arbitration number can be loaded into the CN port by performing a write cycle to any of the receive registers (RXCNO, RXCN1, or RXMSG). The Arbitration Controller will load the number from the CN port instead of the DATA port into the register upon detecting a write to any of the receive registers. The timing is the same as those given for the register write using the DATA port. Refer to Timing Section T2.
2. Next, by performing a read cycle to the register just written to (RXCNO, RXCN1, or RXMSG), the arbitration number stored will be placed onto the DATA port. Thus, the proper operation of the CN port is tested.

14.0 Electrical Characteristics

Absolute Maximum Ratings

If Military/Aerospace specified devices are required, please contact the National Semiconductor Sales Office/Distributors for availability and specifications.

Supply Voltage	6.5V
Control Input Voltage	5.5V
Power Dissipation at 70°C	0.6W
Storage Temperature Range	-65°C to +150°C
Lead Temperature	260°C

Recommended Operating Conditions

	Min	Max	Units
Supply Voltage, V_{DD}	4.5	5.5	V
Operating Free Air Temperature	0	70	C
ESD Tolerance: $C_{ZAP} = 120$ pF, $R_{ZAP} = 1500\Omega$			2kV

Electrical Characteristics (Notes 2 and 3) $T_A = 0^\circ\text{C}$ to $+70^\circ\text{C}$, $V_{CC} = 5V \pm 10\%$

Symbol	Parameter	Conditions	Min	Typ	Max	Units
V_{IH}	Minimum Input High Voltage		2.8			V
V_{IL}	Minimum Input Low Voltage				0.8	V
V_{OH}	Voltage Output High	I_{OH} , I_{OL} for Several Drivers i.e., I_{OL} 4 mA	2.4	3.2		V
V_{OL}	Voltage Output Low	I_{OH} , I_{OL} for Several Drivers i.e., I_{OL} 8 mA		0.35	0.5	V
I_I	Input Leakage Current	Input at V_{DD} or V_{SS}	-1.0		1.0	μA
I_{IH}	Input High Current	Input at V_{IH}			1.0	μA
I_{IL}	Input Low Current	Input at V_{IL}	-1.0			μA
I_{DD}	Supply Current	Dynamic Supply Current			100	mA
I_{CC}	Static Supply Current	Input at Standby			30	mA

Note 1: "Absolute maximum ratings" are those beyond which the safety of the device cannot be guaranteed. They are not meant to imply that the device should be operated at these limits. The table of "Electrical Characteristics" provide conditions for actual device operation.

Note 2: All currents into device pins are positive; all currents out of device pin are negative. All voltages are referenced to device ground unless otherwise specified.

Note 3: All typicals are given for $V_{DD} = 5V$, and $T_A = 25^\circ\text{C}$.

15.0 AC Parameters

Legend to AC Parameter Number Assignments

Parameter Number	Description
t000-t099	Phase 0
t100-t199	Phase 1
t200-t299	Phase 2
t300-t399	Phase 3
t400-t499	Phase 4
t500-t599	Phase 5
tAXX	Reset, Initialization
tBXX	Register Access Data Port
tCXX	Register Access CN Port - Input
tDXX	Clearing Interrupts
tEXX	FIFO Strobe
tFXX	WIN*__GT* Valid
tGXX	Message Signals
tHXX	Busrequest, Busgrant, End of Tenure
tJXX	Locked, Unlock Handshake Signals

15.0 AC Parameters (Continued)

AC Timing Parameters

Unless otherwise stated: $T_A = 0^\circ\text{C}$ to $+70^\circ\text{C}$, $V_{CC} = 5V \pm 10\%$

All transitions are specified after the input signals are stable and valid for evaluation. This table will describe the parameters as given in the following pages. All values are given in nanoseconds (ns), unless otherwise stated.

Number	Symbol	Parameter Description	Min	Typ	Max
t ₁	t _{BQBG}	BRQ* Asserted to BGRNT* Asserted		19	33
t ₂	t _{AQAC}	AQI Negated to AC00, AC10 Negated		22	30
t ₃	t _{APIO}	API Asserted to APO Asserted		16	26
t ₄	t _{RQAP}	MGRQ* or BRQ* Asserted to APO Asserted		19	32
t ₅	t _{EDAP}	(Dummy Cycle) ENDT* Asserted to APO Asserted		28	40
t ₆	t _{BQAP}	(Consecutive Bus Requests) BRQ* Asserted to APO Asserted		17	28
t ₇	t _{HTAP}	HALT* Negated to APO Asserted		16	26
t ₁₀₀	t _{CNLEAR}	CN_LE* Negated to ARO Negated. Determined by Programmable Value		2 + (0 - 25)	4 + (0 - 25)
t ₁₀₁	t _{CNLE}	CN_LE* Width	18	20	26
t ₁₀₂	t _{CNS}	CN Port Setup Time	23	28	
t ₁₀₃	t _{CNZ}	ARI Negated to TRI-STATE CN Port	16	20	
t ₁₀₄	t _{BCAR}	(IBA Mode) IBA-CMPT* Asserted to ARO Negated. Determined by Programmable Value	20 + (0 - 25)	30 + (0 - 25)	
t ₁₀₅	t _{CPSTAR}	CMPT* Asserted to ARO Negated. Determined by Programmable Value	20 + (0 - 25)	30 + (0 - 25)	
t ₁₀₆	t _{AC0AR}	(Slow Mode) AC00 Asserted to ARO Negated. Determined by Programmable Value	20 + (0 - 25)	30 + (0 - 25)	
t ₁₀₇	t _{APCNLE}	APO Asserted to CN-LE* Asserted. CTRL3[0], "G0" Bit is Set		22	32
t ₁₀₈	t _{APCPTA}	APO Asserted to CMPT* Asserted		14	22
t ₁₀₉	t _{APIBC}	APO Asserted to IBA_CMPT* Asserted		13	18
t ₁₁₀	t _{APAC}	APO Asserted to AC00 Asserted (Slow Mode)		18	28
t ₂₀₀	t _{ARABRD}	ARI Negated to AB_RE* Asserted		52	62
t ₂₀₁	t _{ARIBS}	(IBA Mode) ARI Negated to IBA_S*. T _A = Arbitration Timer 60-300		T _A	T _A
t ₂₀₂	t _{BSSBG}	(IBA Mode) IBA_S* Asserted to BGRNT* Asserted		19	33
t ₂₀₃	t _{WINAQ}	WIN*_GT* Asserted to AQO Asserted. After T _A Expired.		18	29
t ₂₀₄	t _{AQIO}	AQI Asserted to AQO Asserted		13	20
t ₂₀₅	t _{ARAQ}	ARI Negated to AQO Asserted		18 + T _A	28 + T _A
t ₂₀₇	t _{BBSAQ}	(IBA Mode) IBA-S* Asserted to AQO Asserted		20	33
t ₃₀₀	t _{AC10AP}	AC10 Asserted to APO Negated		15	29
t ₃₀₁	t _{ASNAP}	AS_Cancel* Negated to APO Negated		15	24
t ₃₁₀	t _{APABRD}	APO Negated to AB_RE* Negated		5	8
t ₃₂₀	t _{AQAC1}	AQO Asserted to AC10 Asserted		6	10
t ₃₂₁	t _{AC11APN}	AC11 Asserted to APO Negated	7	12	18
t ₃₂₂	t _{ASAAP}	AS_Cancel* Asserted to APO Negated	7	12	18
t ₃₃₀	t _{AC11AP}	AC11 Asserted to APO Negated		13	22
t ₃₄₀	t _{RQAC}	MGRQ* or BRQ* Negated to AC00, AC10 Asserted		21	32
t ₃₄₁	t _{AQAC0}	AQO Asserted to AC00 Negated		0	3
t ₃₄₂	t _{AQER}	AQO Asserted to ERIT* Asserted		14	22
t ₄₀₀	t _{APCPTN}	API Negated to CMPT* Negated		18	30

15.0 AC Parameters (Continued)

AC Timing Parameters Unless otherwise stated: $T_A = 0^\circ\text{C}$ to $+70^\circ\text{C}$, $V_{CC} = 5V \pm 10\%$ (Continued)

All transitions are specified after the input signals are stable and valid for evaluation. This table will describe the parameters as given in the following pages. All values are given in nanoseconds (ns), unless otherwise stated.

Number	Symbol	Parameter Description	Min	Typ	Max
t ₄₀₁	t _{AC1IAR}	AC1I Asserted to ARO Asserted		12	21
t ₄₀₃	t _{CANAC1}	AS_Cancel* Asserted to AC1O Asserted	7		19
t ₄₀₅	t _{ARIO}	ARI Asserted to ARO Asserted		14	19
t ₄₀₇	t _{EDAR}	ENDT* Asserted to ARO Asserted		15	25
t ₅₀₀	t _{ARBG}	ARO Asserted to BGRNT* Asserted		7	12
t ₅₀₁	t _{DAQ}	BGRNT*, MGTX*, UNLK* or any Interrupt Asserted to AQO Negated	5	7	
t ₅₀₂	t _{ARFTR}	ARO Asserted to FSTR* Negated		5	8
t ₅₀₃	t _{ARIBC}	ARO Asserted to IBA_CMPT* Negated		5	8
t ₅₀₄	t _{ARABSA}	ARO Asserted to MGTX*, UNLK* or any Interrupt Asserted		5	9
t _{A1}	t _{RSTPW}	RST* Pulse Width	50	50	
t _{A2}	t _{RSTRE}	Output Reset Time		30	45
t _{A3}	t _{RSTAR}	RST* Negated to ARO Asserted		15	25
t _{A4}	t _{RINTPW}	RINT* Pulse Width	50	50	
t _{A5}	t _{RINTRE}	Output Initialization Reset Time		30	45
t _{B1}	t _{CSPW}	CS* Pulse Width	35		
t _{B2}	t _{CSPWN}	CS* Recovery Time	15		
t _{B3}	t _{CSDKA}	CS* Asserted to DSACK* Asserted		12	18
t _{B4}	t _{ADDs}	ADD (3:0) Setup Time	5	2	
t _{B5}	t _{ADDH}	ADD (3:0) Hold Time	6	5	
t _{B6}	t _{CSDKN}	CS* Negated to DSACK* Negated	7	12	
t _{B7}	t _{RWS}	R_W* Setup Time	0		
t _{B8}	t _{SELS}	SEL Setup Time	0		
t _{B10}	t _{DATASDK}	Data (7:0) Setup Time with Respect to DSACK*	24	15	
t _{B11}	t _{DATAHDK}	Data (7:0) Hold Time with Respect to DSACK*	0	0	
t _{B12}	t _{SELH}	SEL Hold Time	3		
t _{B24}	t _{DATASCS}	Data (7:0) Setup Time with Respect to CS* Negated	15	6	
t _{B25}	t _{DATAHCS}	Data (7:0) Hold Time with Respect to CS* Negated	5	5	
t _{B27}	t _{DATALZ}	Data (7:0) Low Z Time		14	22
t _{B28}	t _{DATAV}	Data (7:0) Valid Time before DSACK*			
t _{B29}	t _{DATAA}	Data (7:0) Access Time with Respect to CS* Asserted		22	30
t _{B30}	t _{DATAHRC}	Data (7:0) Hold Time	6	10	
t _{B31}	t _{DATAHZ}	Data (7:0) Hi-Z Time		12	25
t _{C2}	t _{ABRDCNZ}	AB_RE* Negated to CN (7:0) TRI-STATE	0	0	
t _{D1}	t _{CSXINTN}	CS* Asserted to any Interrupt Negated		22	36
t _{E1}	t _{FSTR}	FSTR* Recovery Time	80		

15.0 AC Parameters (Continued)

AC Timing Parameters

Unless otherwise stated: $T_A = 0^\circ\text{C}$ to $+70^\circ\text{C}$, $V_{CC} = 5V \pm 10\%$ (Continued)

All transitions are specified after the input signals are stable and valid for evaluation. This table will describe the parameters as given in the following pages. All values are given in nanoseconds (ns), unless otherwise stated.

Number	Symbol	Parameter Description	Min	Typ	Max
t_{E2}	$t_{FSTABRD}$	AB_RE* High Time with Respect to FSTR*	60		
t_{F1}	$t_{WINALL1}$	ALL1* Asserted with Respect to WIN*_GT*			5
t_{F2}	t_{WINPER}	PER* Asserted with Respect to WIN*_GT*			5
t_{G1}	t_{MGXN}	MGRQ* Negated to MGTX* Negated		14	22
t_{H2}	t_{EDBGN}	ENDT* Asserted to BGRNT* Negated		17	25
t_{J1}	t_{LKULKN}	LKD* Negated to UNLK* Negated		12	18

Phase 0 Timing

A. Transitioning Into and Out of Phase 0

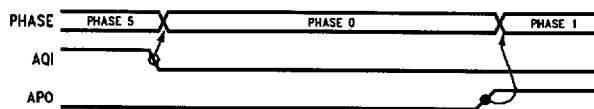

TL/H/10747-31

B. Parking (Assume !IBA_PK*)

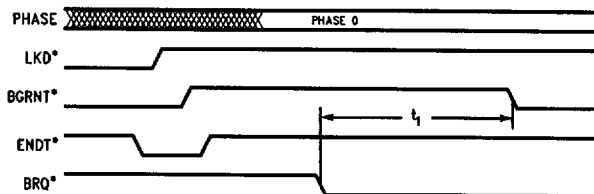

TL/H/10747-32

C. Negating AC10 and AC00 When Entering Phase 0

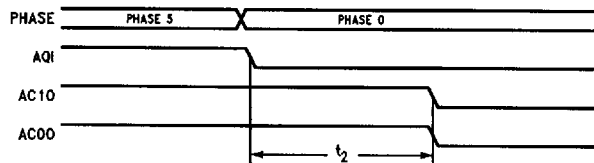

TL/H/10747-33

D. Another Module Initiating Competition

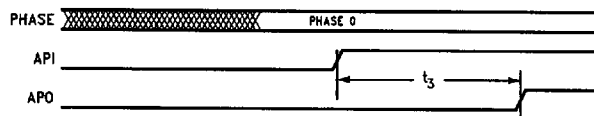

TL/H/10747-34

15.0 AC Parameters (Continued)

Phase 0 Timing (Continued)

E. Message Request or Bus Request Initiating Competition

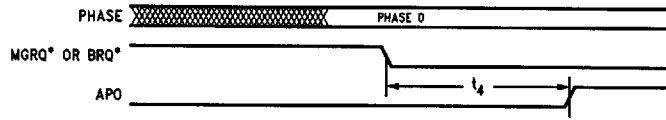

TL/H/10747-35

F. Dummy Cycle to Generate Unlock (! UNLK*) During Phase 5

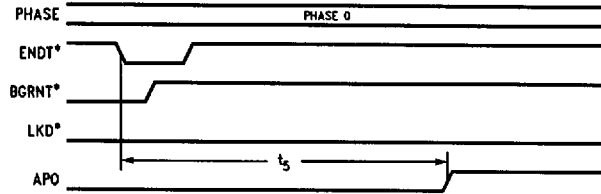

TL/H/10747-38

G. Consecutive Bus Requests: Parking

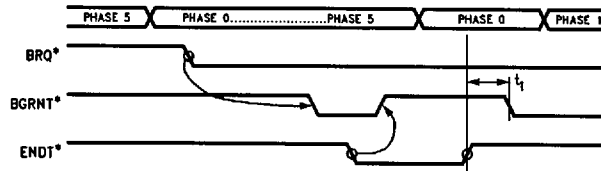

TL/H/10747-37

H. HALT* Release



TL/H/10747-75

I. Consecutive Bus Requests: Non-Parking

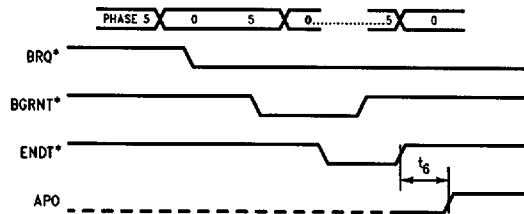

TL/H/10747-78

15.0 AC Parameters (Continued)

Phase 1 Timing

A) TRANSITIONING INTO AND OUT OF PHASE 1

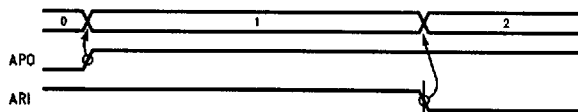

B) REGISTER ACCESS CN PORT - OUTPUT

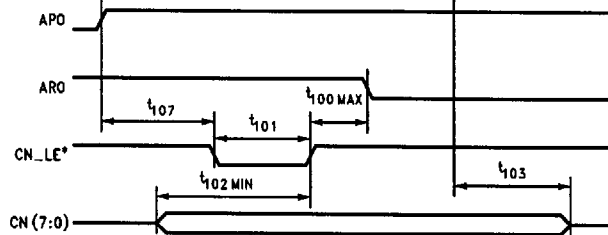

TL/H/10747-38

C. IBA Mode Selected

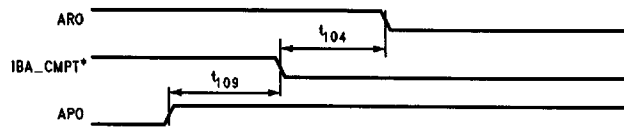

TL/H/10747-39

D. Competing

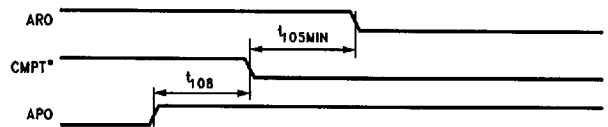

TL/H/10747-40

E. Asserting AC00 - Slow Mode (F_S*) Is Selected

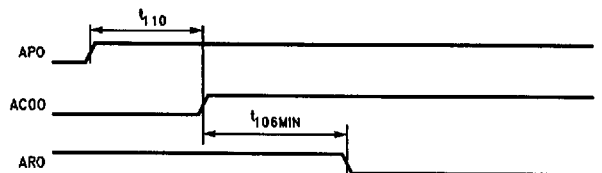

TL/H/10747-41

15.0 AC Parameters (Continued)

Phase 2 Timing

A. Transitioning Into and Out of Phase 2

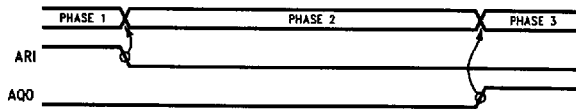

TL/H/10747-42

B. Register Access CN Port-Input

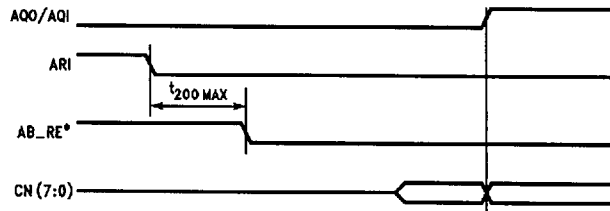

TL/H/10747-43

C. IBA Mode Selected-Winner of Competition

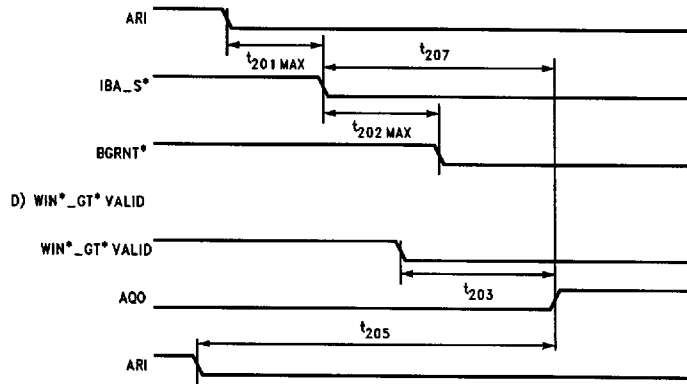

TL/H/10747-44

E. Bystander

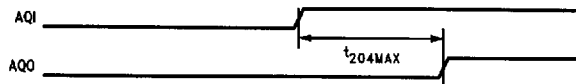

TL/H/10747-45

15.0 AC Parameters (Continued)

Phase 3 Timing

A. Transitioning Into and Out of Phase 3

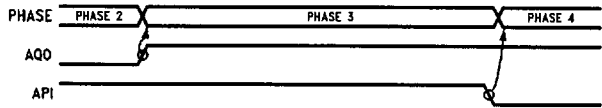

TL/H/10747-46

B. AS Low and No Errors

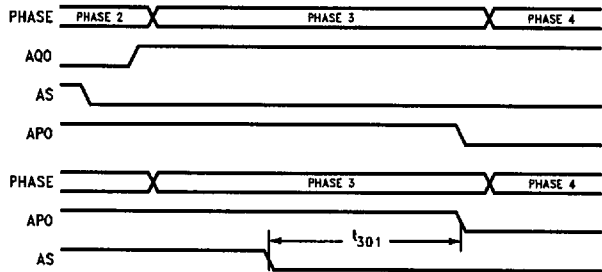

TL/H/10747-47

C. Reading the Winning Competition Number (I AB_RE*)

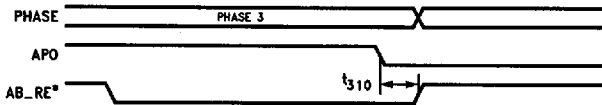

TL/H/10747-48

D. Successful IBA Competition Timing

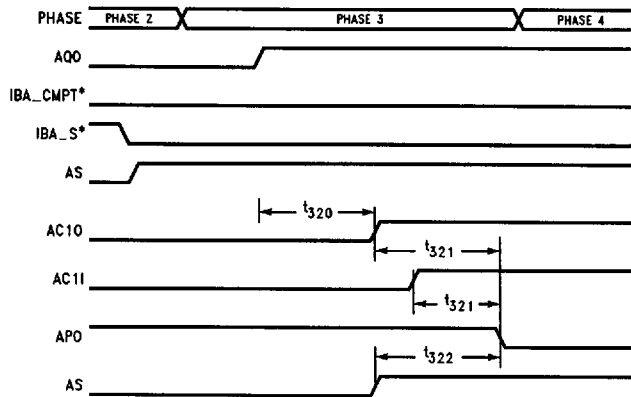

TL/H/10747-49

E. Transfer of Tenure Inhibited

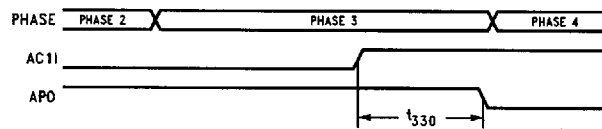

TL/H/10747-50

15.0 AC Parameters (Continued)

Phase 3 Timing (Continued)

F. Message Request or Bus Request Being Negated During Phase 3 (If This Module was the Winner)

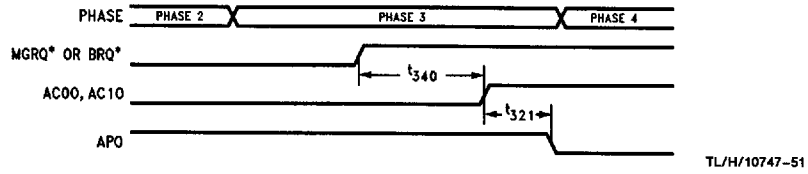

G. Second Pass Required

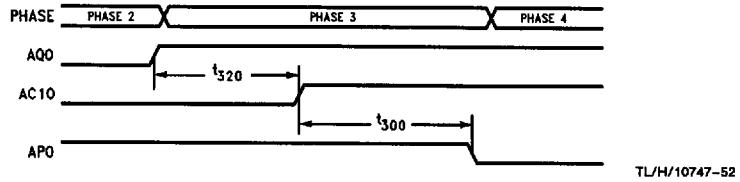

H. Slow Case ACO Recovery

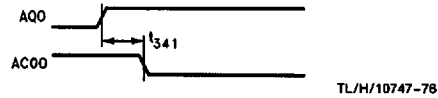

Phase 4 Timing

A. Transitioning Into and Out of Phase 4

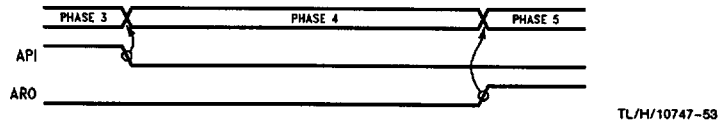

B. Complete Signal is Negated

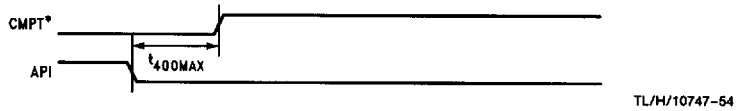

C. Inhibit Transfer of Tenure

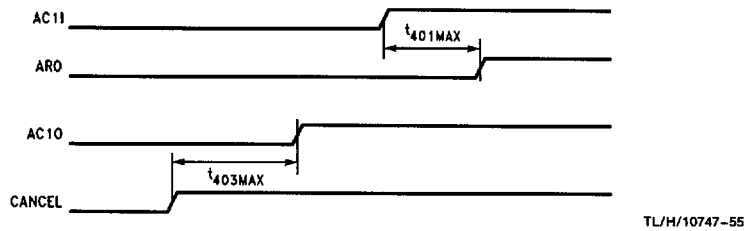

15.0 AC Parameters (Continued)

Phase 4 Timing (Continued)

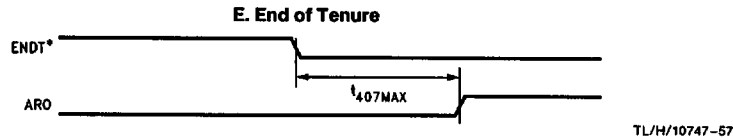
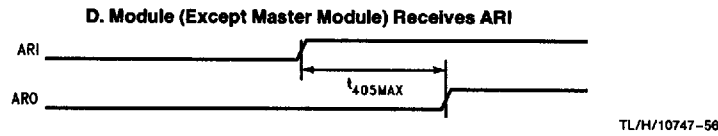

Phase 5 Timing

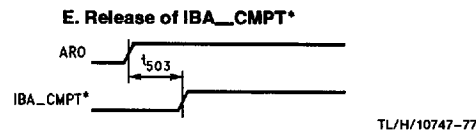
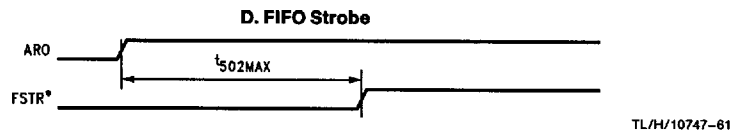
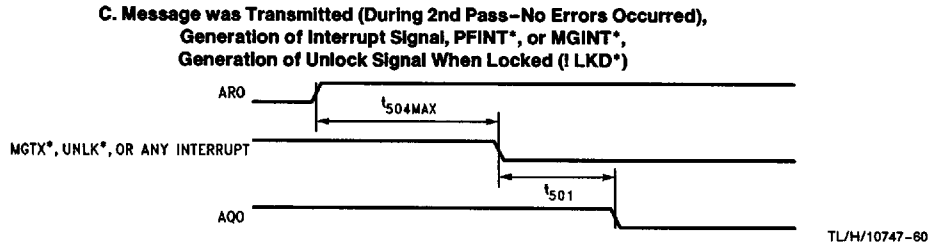
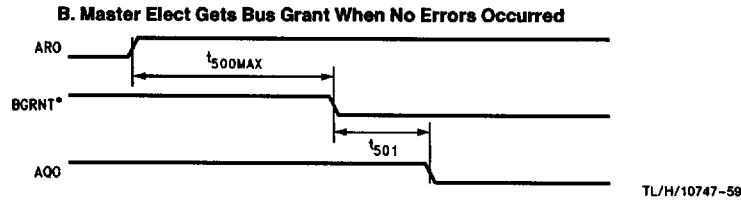
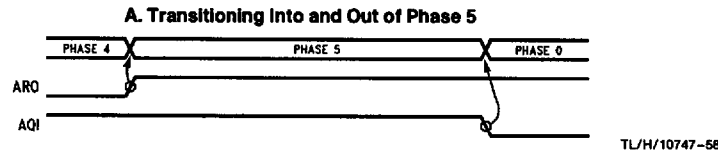

15.0 AC Parameters (Continued)

T1a. RST* Signal

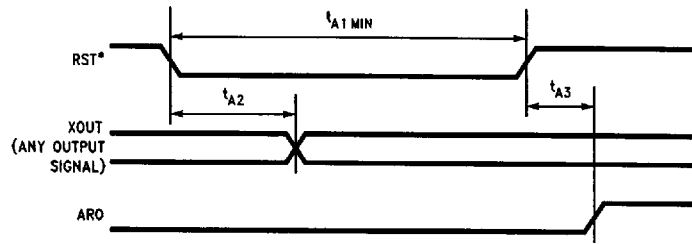

TL/H/10747-62

T1b. RINT* Signal

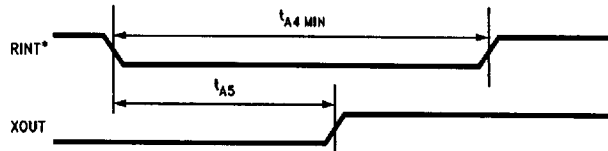

TL/H/10747-63

T2a. Register Access DATA Port- WRITE CYCLE USING DSACK*

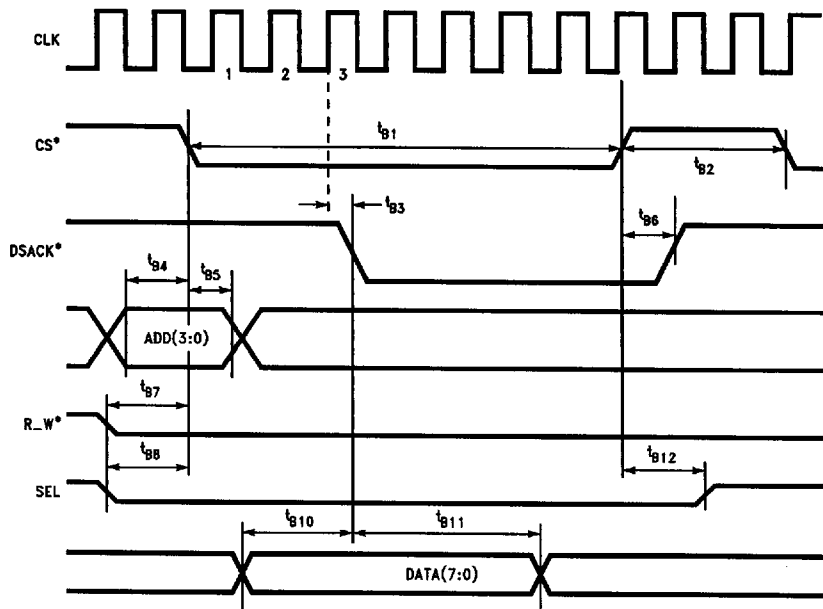

TL/H/10747-64

15.0 AC Parameters (Continued)

T2b. Register Access DATA Port-Write CYCLE Using CS*

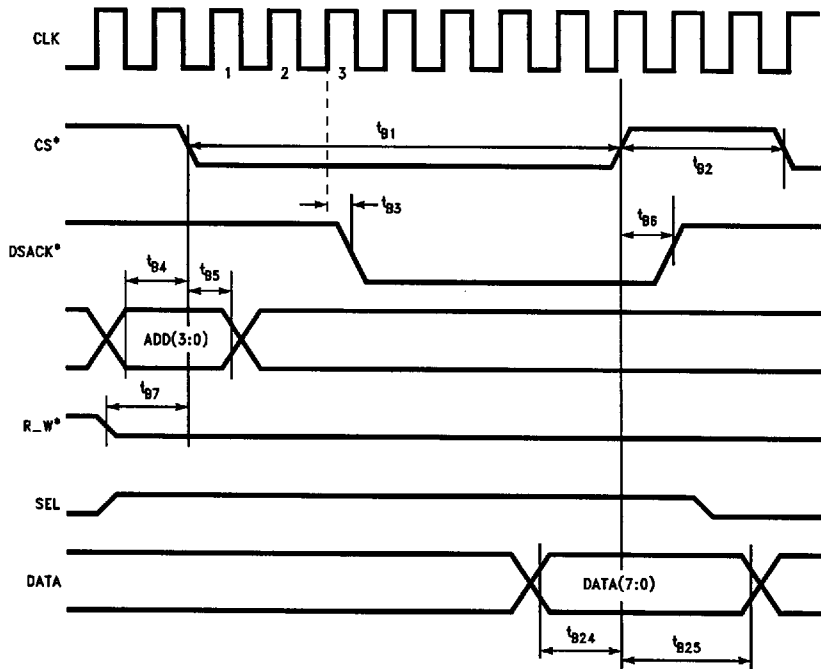

TL/H/10747-65

T2c. Register Access DATA Port-Read CYCLE

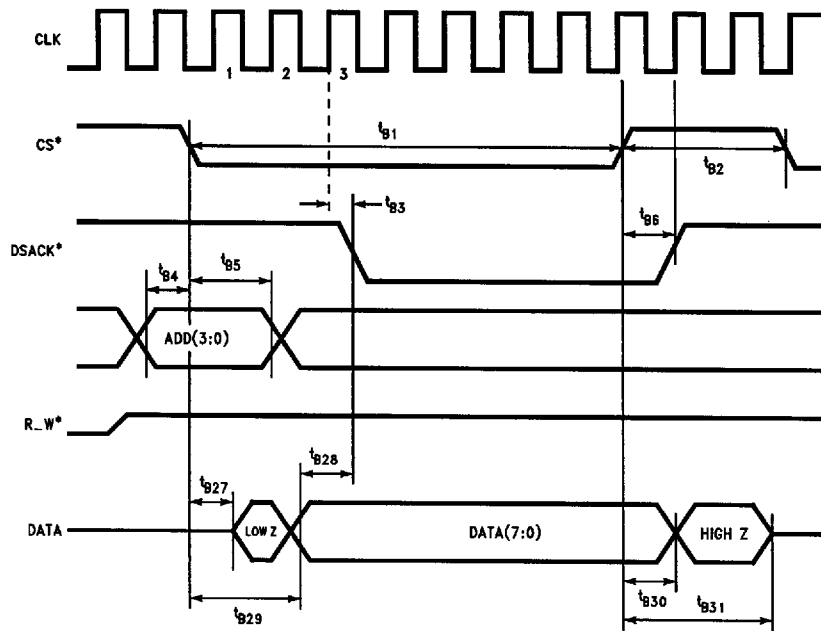

TL/H/10747-66

15.0 AC Parameters (Continued)

T3. Register Access CN Port-Input

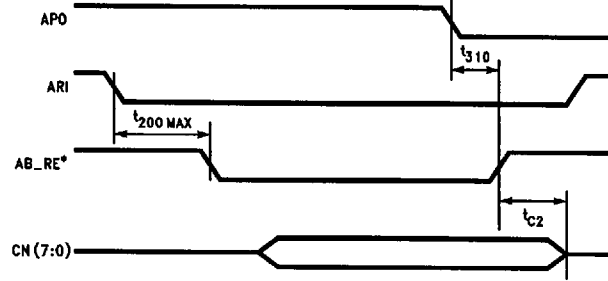

TL/H/10747-67

T4. Register Access CN Port-Output

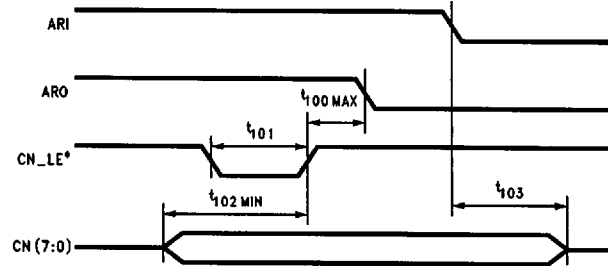

TL/H/10747-68

These sections are shown to give a better understanding of the CN port timing. Most of the parameters are given under the phase timing diagrams. Also a few parameters are added here to these diagrams.

T5. Clearing Interrupts

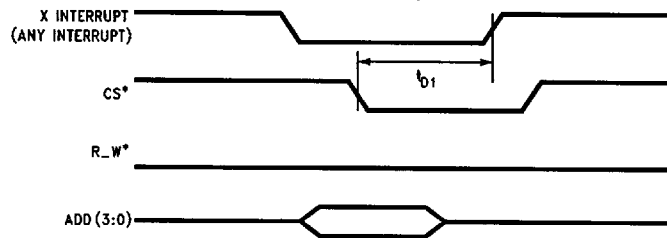

TL/H/10747-69

15.0 AC Parameters (Continued)

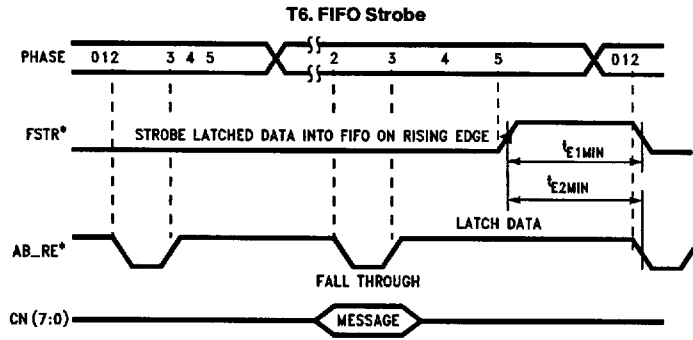

TL/H/10747-70

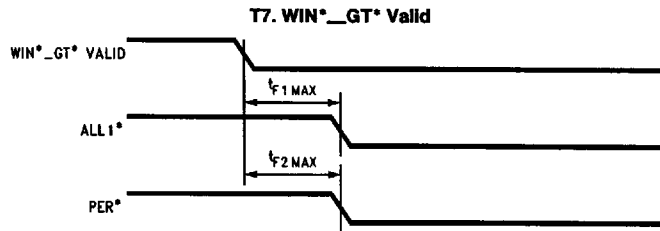

TL/H/10747-71

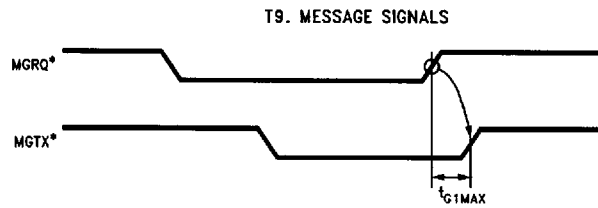
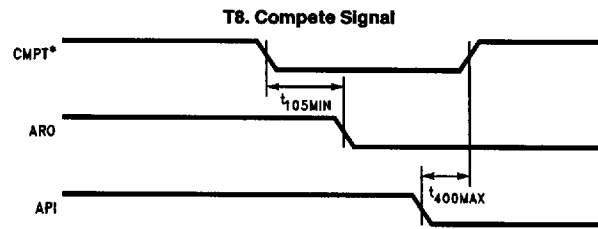

TL/H/10747-72

These sections give some additional parameters, these are not the complete set of parameters specified for these signals. Also refer to the phase timing diagrams.

15.0 AC Parameters (Continued)

T10. BUSREQUEST, BUSGRANT and END of TENURE HANDSHAKE

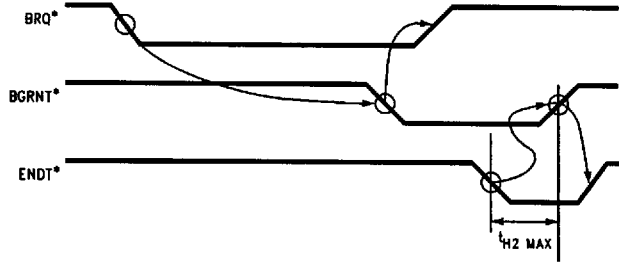

TL/H/10747-73

T11. LKD* and UNLK* Handshake Signals

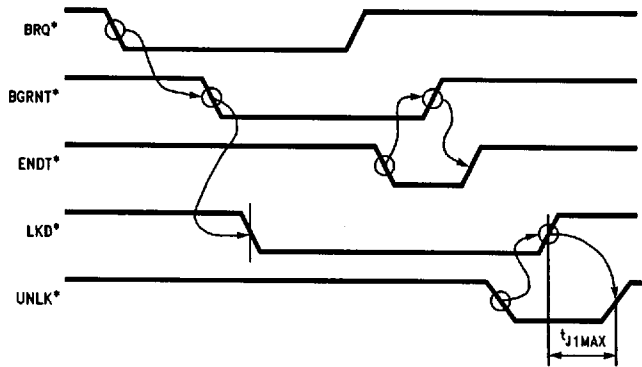

TL/H/10747-74

Physical Dimensions inches (millimeters)

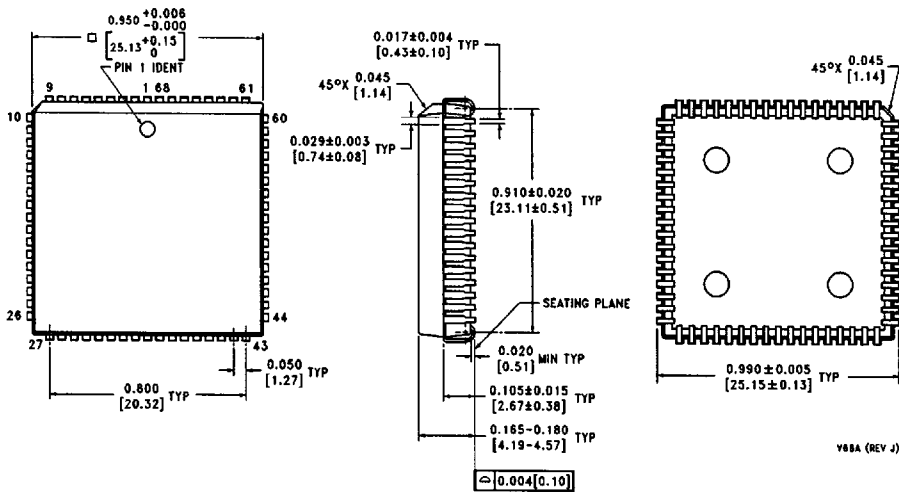

Order Number DS3875V
NS Package V68A

LIFE SUPPORT POLICY

NATIONAL'S PRODUCTS ARE NOT AUTHORIZED FOR USE AS CRITICAL COMPONENTS IN LIFE SUPPORT DEVICES OR SYSTEMS WITHOUT THE EXPRESS WRITTEN APPROVAL OF THE PRESIDENT OF NATIONAL SEMICONDUCTOR CORPORATION. As used herein:

1. Life support devices or systems are devices or systems which, (a) are intended for surgical implant into the body, or (b) support or sustain life, and whose failure to perform, when properly used in accordance with instructions for use provided in the labeling, can be reasonably expected to result in a significant injury to the user.
2. A critical component is any component of a life support device or system whose failure to perform can be reasonably expected to cause the failure of the life support device or system, or to affect its safety or effectiveness.

 <p>National Semiconductor Corporation 1111 West Bardin Road Arlington, TX 76017 Tel: 1(800) 272-9959 Fax: 1(800) 737-7018</p>	<p>National Semiconductor Europe Fax: (+49) 0-180-530 85 86 Email: cnjwge@tevm2.nsc.com Deutsch Tel: (+49) 0-180-530 85 85 English Tel: (+49) 0-180-532 78 32 Français Tel: (+49) 0-180-532 93 58 Italiano Tel: (+49) 0-180-534 16 80</p>	<p>National Semiconductor Hong Kong Ltd. 13th Floor, Straight Block, Ocean Centre, 5 Canton Rd. Tsimshatsui, Kowloon Hong Kong Tel: (852) 2737-1600 Fax: (852) 2736-9960</p>	<p>National Semiconductor Japan Ltd. Tel: 81-043-299-2309 Fax: 81-043-299-2408</p>
--	--	---	---

National does not assume any responsibility for use of any circuitry described, no circuit patent licenses are implied and National reserves the right at any time without notice to change said circuitry and specifications.

58