

DRAWING FOR REFERENCE: This is subject to change without notice
08/11/2012

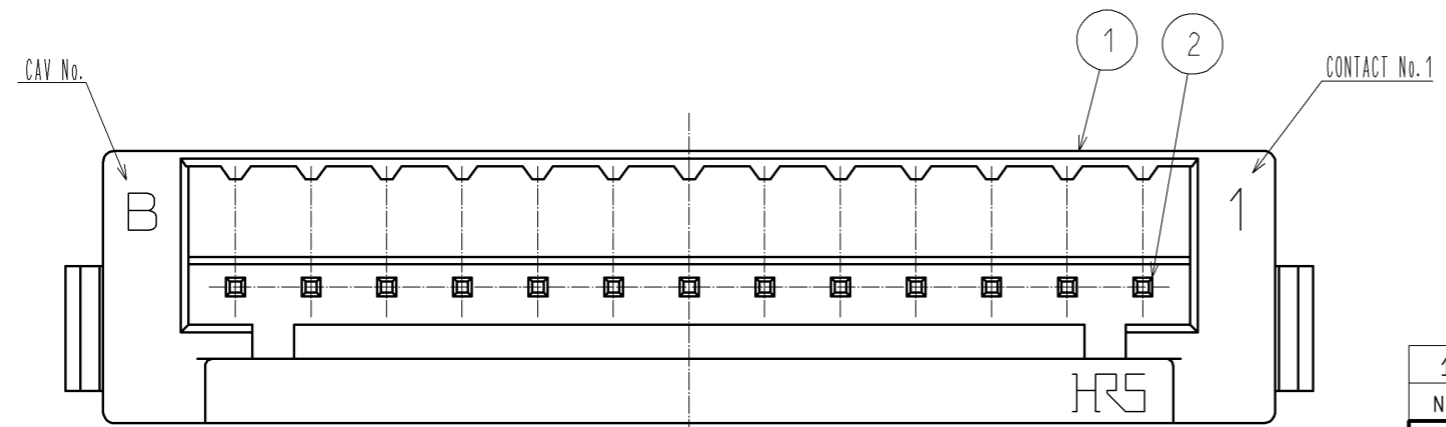
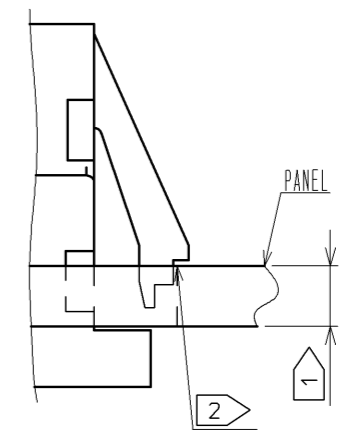
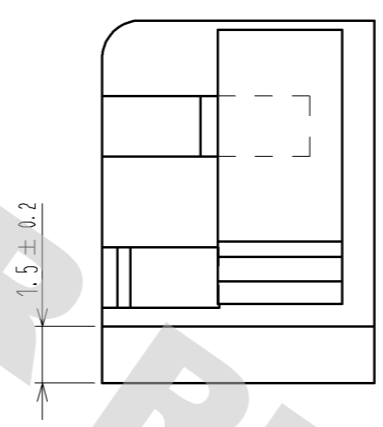
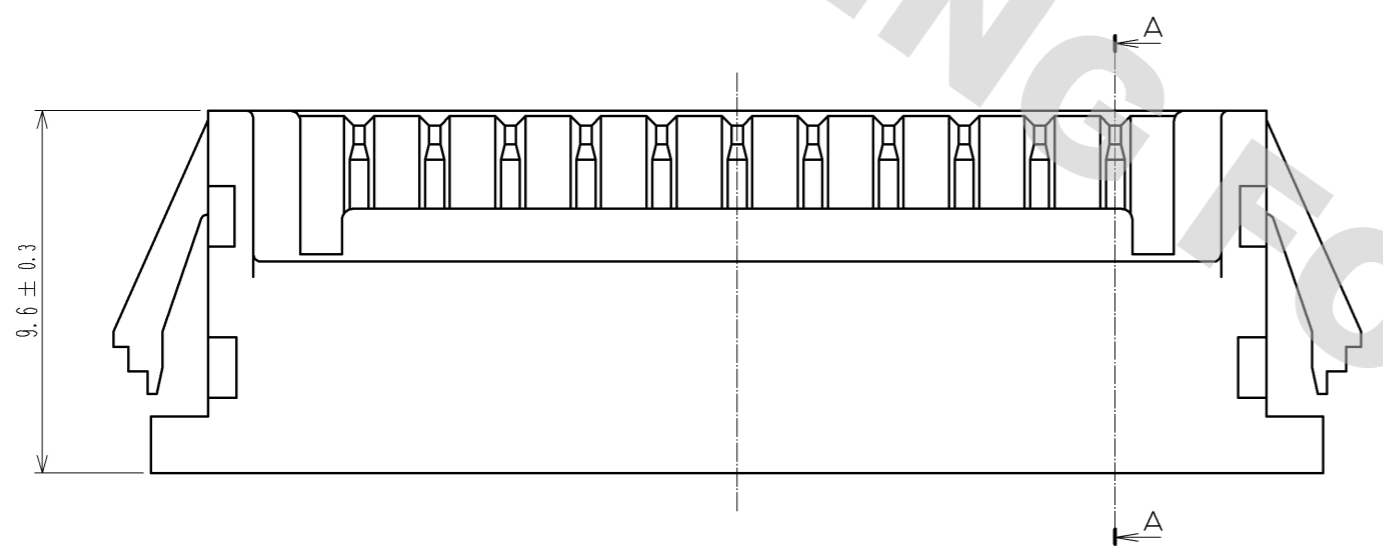
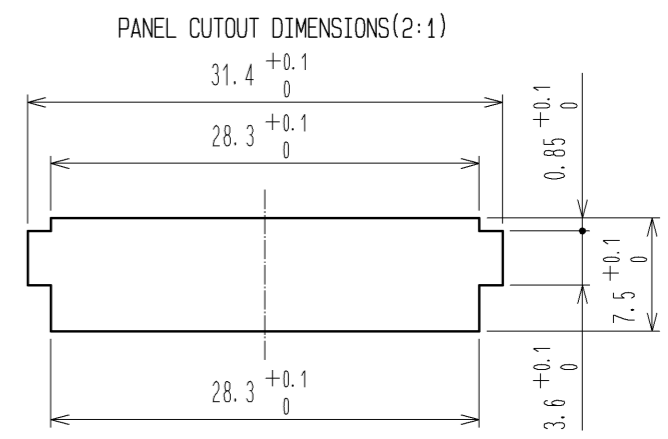
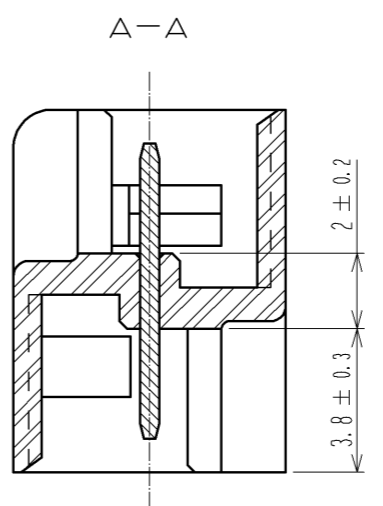
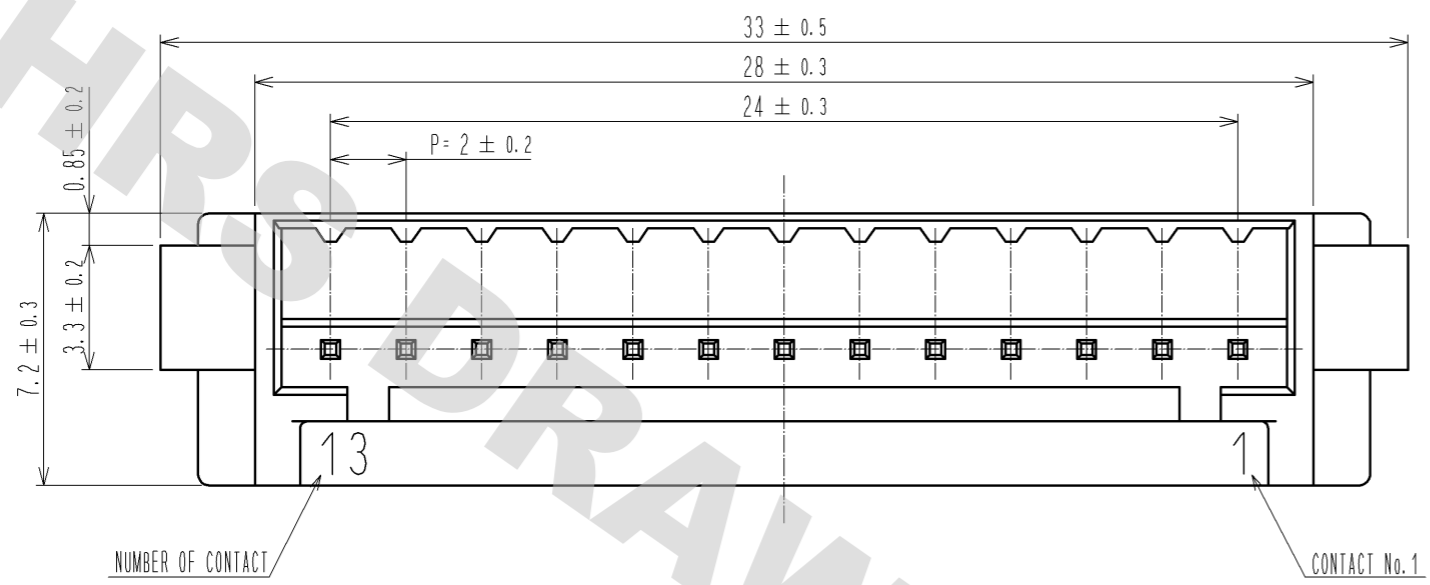

NOTE 1 APPLICABLE PANEL THICKNESS : 1.6~0.8mm
(NOTE THAT SOME LOOSENESS IS UNAVOIDABLE WHEN THE PLUGS ARE MOUNTED ON A PANEL OF OTHER THAN 1.6 OR 2.2mm THICKNESS.)
2 USE THE SHARP EDGE FOR ENGAGEMENT WITH THE PANEL.

1	POLYAMIDE	UL94V-0. BLACK	2	BRASS	SURFACE:TIN PLATING 1μm min UNDER PLATING:NICKEL PLATED 0.5μm min
NO.	MATERIAL	FINISH . REMARKS	NO.	MATERIAL	FINISH . REMARKS
UNITS mm		SCALE 5 : 1	COUNT 	DESCRIPTION OF REVISIONS	DESIGNED
HIROSE ELECTRIC CO., LTD.				APPROVED : TS. SAKATA	08.11.25
				CHECKED : TS. KUMAZAWA	08.11.20
				DESIGNED : KT. ISHII	08.11.19
				DRAWN : KT. ISHII	08.11.19
				DRAWING NO.	EDC3-160491-01
				PART NO.	DF3-13EP-2A
				CODE NO.	CL543-0278-6-00
				1/1	