

***THIS DOCUMENT IS FOR MAINTENANCE
PURPOSES ONLY AND IS NOT
RECOMMENDED FOR NEW DESIGNS***

SL561

ULTRA LOW NOISE PREAMPLIFIERS

This integrated circuit is a high gain, low noise preamplifier designed for use in audio and video systems at frequencies up to 6MHz. Operation at low frequencies is eased by the small size of the external components and the low 1/f noise. Noise performance is optimised for source impedances between 20Ω and 1 kΩ making the device suitable for use with a number of transducers including photo-conductive IR detectors, magnetic tape heads and dynamic microphones.

The SL561 B is only available in the TO-5 package
The SL561 C is only available in the Plastic package.

FEATURES

- High Gain 60dB
- Low Noise 0.8nV/√Hz (Rs = 50Ω)
- Bandwidth 6MHz
- Low Power Consumption 10mW (V_{CC} = 5V)

APPLICATIONS

- Audio Preamplifiers (low noise from low impedance source)
- Video Preamplifier
- Preamplifier for use in Low Cost Infra-Red Systems

ORDERING INFORMATION

SL561 AC CM

SL561 C DP

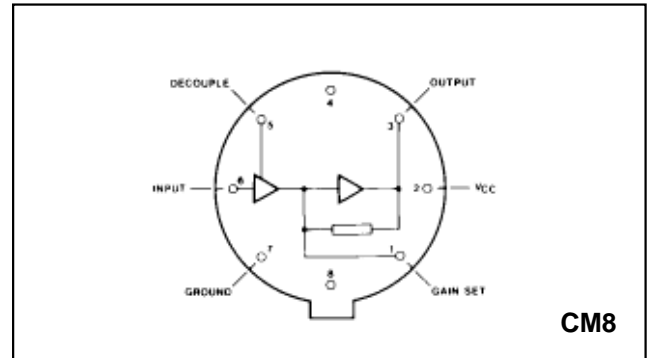

Fig.1 Pin connections (view as above) SL561B

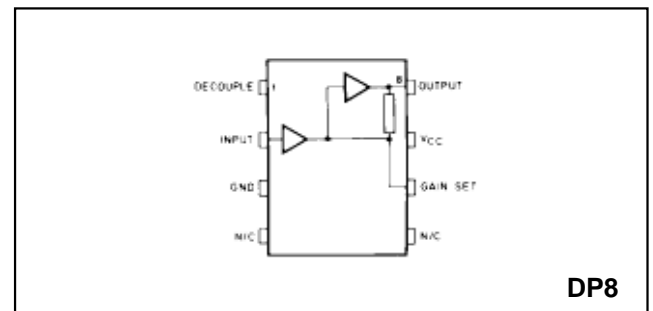

Fig.2 Pin connections (view as above) SL561C

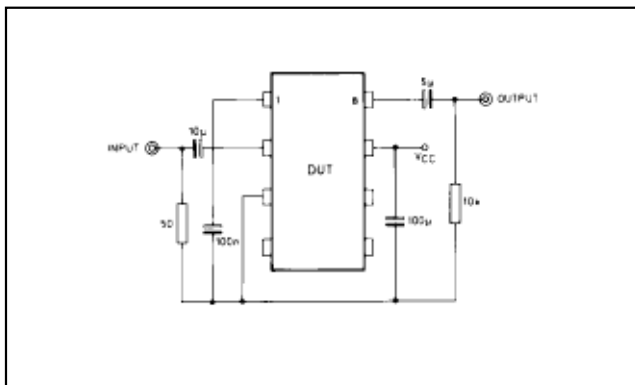

Fig.3 Test circuit

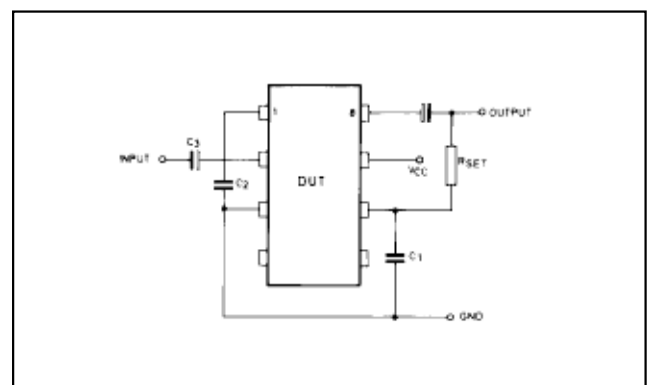

Fig.4 Typical application

SL561

ELECTRICAL CHARACTERISTICS

These characteristics are guaranteed over the following conditions (unless otherwise stated):

V_{CC}	5V
Source impedance	50Ω
Load impedance	10kΩ
T_{amb}	25°C

SL561C

Characteristic	Value			Units	Conditions
	Min.	Typ.	Max.		
Voltage gain	57	60	63	dB	Pin 6 O/C 100Hz to 6MHz
Equivalent input noise voltage		0.8		nV/√Hz	
Input resistance		3		kΩ	See note
Input capacitance		15		pF	
Output impedance		50		Ω	
Output voltage	2	3		V p-p	
Supply current		2	3	mA	
Bandwidth		6		MHz	

OPERATING NOTES (Pin numbers refer to DIL package)

Upper cut-off frequency

The bandwidth of the amplifier can be reduced from 6MHz to any desired value by a capacitor from pin 6 to ground. This is shown in Fig.5. No degradation in noise or output swing occurs when this capacitor is used. The high frequency roll off is approximately 6dB/octave.

Low frequency response

The capacitors C_2 and C_3 (Fig.4) determine the lower cut-off frequency. C_2 decouples an internal feedback loop and if its value is close to that of C_3 an increase in gain at low frequencies can occur. For a flat response either make C_2 less than $0.05 C_3$ or make C_2 greater than $5 C_3$.

Gain set facility

Provision is made to adjust the gain by means of a resistor between pin 6 and the output. Gains as low as 10dB can be selected. This resistor increases the feedback around the output stage and stability problems can result if the bandwidth of the amplifier is not reduced as indicated in Note 1. Fig.6 shows recommended values of C_1 for each gain range. Since the input stage is a common emitter stage without emitter degeneration (for best noise) at values of gain less than 40dB this input stage, rather than the output stage, determines the

maximum output voltage swing. For a distortion of less than 10% the input voltage should be restricted to less than 5mV (see Fig.9).

Driving low impedance loads

The quiescent current of the output emitter follower is 0.5mA. If larger voltage swings are required into low impedance loads this current can be increased by a resistor from pin 8 to ground. To avoid exceeding the ratings of the output transistor the resistor should not be less than 200Ω.

Noise performance

The equivalent input voltage for the amplifier is shown in Fig.7. From this the input noise voltage and current generators can be derived. They are:

$$e_n = 0.8nV/\sqrt{Hz}$$

$$i_n = 2.0pA/\sqrt{Hz}$$

Flicker or 1/f noise is not normally a problem, the knee frequency being typically below 100Hz.

ABSOLUTE MAXIMUM RATINGS

Supply Voltage	+10V
Storage Temperature Range	
SL561 CM	-65°C to +150°C
SL561 DP	-55°C to +150°C
Operating Temperature Range	
SL561 AC	-55°C to +125°C
SL561 C	-30°C to +85°C
Thermal Resistance	
Chip - to - Ambient	
SL561 CM	225°C/W
SL561 DP	111°C/W
Chip - to - case	
SL561 CM	65°C/W
SL561 DP	71°C/W

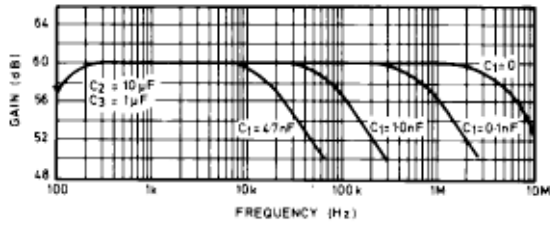

Fig.5 Gain v. frequency

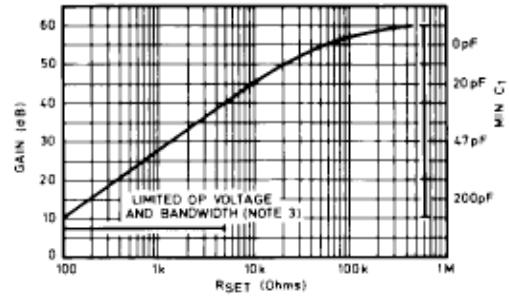

Fig.6 Gain v. Rset

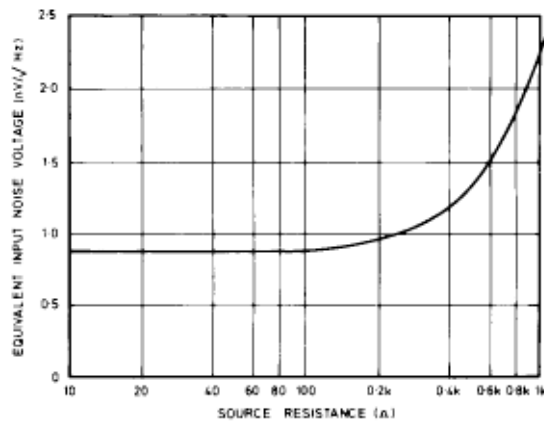

Fig.7 Noise v. source impedance

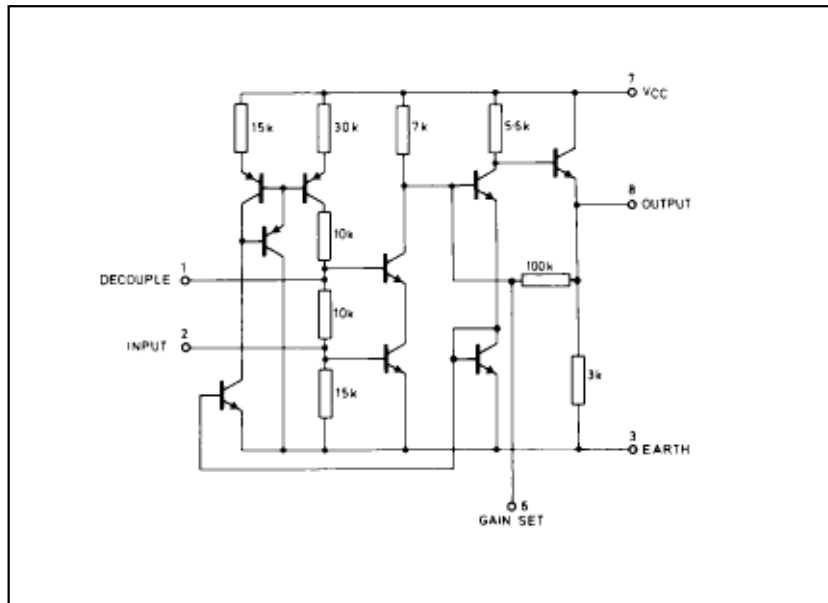

Fig.8 Circuit diagram

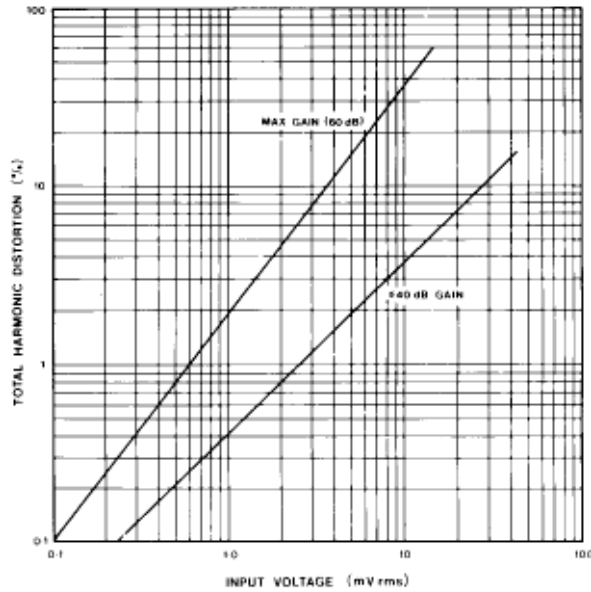

Fig.9 Harmonic distortion SL561 at 20kHz



HEADQUARTERS OPERATIONS
GEC PLESSEY SEMICONDUCTORS
 Cheney Manor, Swindon,
 Wiltshire SN2 2QW, United Kingdom.
 Tel: (0793) 518000
 Fax: (0793) 518411

GEC PLESSEY SEMICONDUCTORS
 P.O. Box 660017
 1500 Green Hills Road,
 Scotts Valley, California 95067-0017,
 United States of America.
 Tel: (408) 438 2900
 Fax: (408) 438 5576

CUSTOMER SERVICE CENTRES

- **FRANCE & BENELUX** Les Ulis Cedex Tel: (1) 64 46 23 45 Fax : (1) 64 46 06 07
- **GERMANY** Munich Tel: (089) 3609 06-0 Fax : (089) 3609 06-55
- **ITALY** Milan Tel: (02) 66040867 Fax: (02) 66040993
- **JAPAN** Tokyo Tel: (03) 5276-5501 Fax: (03) 5276-5510
- **NORTH AMERICA** Scotts Valley, USA Tel (408) 438 2900 Fax: (408) 438 7023.
- **SOUTH EAST ASIA** Singapore Tel: (65) 3827708 Fax: (65) 3828872
- **SWEDEN** Stockholm, Tel: 46 8 702 97 70 Fax: 46 8 640 47 36
- **UK, EIRE, DENMARK, FINLAND & NORWAY**
 Swindon Tel: (0793) 518510 Fax : (0793) 518582

These are supported by Agents and Distributors in major countries world-wide.

© GEC Plessey Semiconductors 1994

This publication is issued to provide information only which (unless agreed by the Company in writing) may not be used, applied or reproduced for any purpose nor form part of any order or contract nor to be regarded as a representation relating to the products or services concerned. No warranty or guarantee express or implied is made regarding the capability, performance or suitability of any product or service. The Company reserves the right to alter without prior knowledge the specification, design or price of any product or service. Information concerning possible methods of use is provided as a guide only and does not constitute any guarantee that such methods of use will be satisfactory in a specific piece of equipment. It is the user's responsibility to fully determine the performance and suitability of any equipment using such information and to ensure that any publication or data used is up to date and has not been superseded. These products are not suitable for use in any medical products whose failure to perform may result in significant injury or death to the user. All products and materials are sold and services provided subject to the Company's conditions of sale, which are available on request.