



## 6-Pin DIP Optoisolators Darlington Output

The 4N29/A, 4N30, 4N31, 4N32<sup>(1)</sup> and 4N33<sup>(1)</sup> devices consist of a gallium arsenide infrared emitting diode optically coupled to a monolithic silicon photodarlington detector.

This series is designed for use in applications requiring high collector output currents at lower input currents.

- Higher Sensitivity to Low Input Drive Current
- Meets or Exceeds All JEDEC Registered Specifications
- **To order devices that are tested and marked per VDE 0884 requirements, the suffix "V" must be included at end of part number. VDE 0884 is a test option.**

### Applications

- Low Power Logic Circuits
- Interfacing and coupling systems of different potentials and impedances
- Telecommunications Equipment
- Portable Electronics
- Solid State Relays

### MAXIMUM RATINGS ( $T_A = 25^\circ\text{C}$ unless otherwise noted)

Rating	Symbol	Value	Unit
--------	--------	-------	------

#### INPUT LED

Reverse Voltage	$V_R$	3	Volts
Forward Current — Continuous	$I_F$	60	mA
LED Power Dissipation @ $T_A = 25^\circ\text{C}$ Derate above $25^\circ\text{C}$	$P_D$	120 1.41	mW mW/ $^\circ\text{C}$

#### OUTPUT DETECTOR

Collector–Emitter Voltage	$V_{CEO}$	30	Volts
Emitter–Collector Voltage	$V_{ECO}$	5	Volts
Collector–Base Voltage	$V_{CBO}$	30	Volts
Collector Current — Continuous	$I_C$	150	mA
Detector Power Dissipation @ $T_A = 25^\circ\text{C}$ Derate above $25^\circ\text{C}$	$P_D$	150 1.76	mW mW/ $^\circ\text{C}$

#### TOTAL DEVICE

Isolation Surge Voltage <sup>(2)</sup> (Peak ac Voltage, 60 Hz, 1 sec Duration)	$V_{ISO}$	7500	Vac(pk)
Total Device Power Dissipation @ $T_A = 25^\circ\text{C}$ Derate above $25^\circ\text{C}$	$P_D$	250 2.94	mW mW/ $^\circ\text{C}$
Ambient Operating Temperature Range <sup>(3)</sup>	$T_A$	-55 to +100	$^\circ\text{C}$
Storage Temperature Range <sup>(3)</sup>	$T_{stg}$	-55 to +150	$^\circ\text{C}$
Soldering Temperature (10 sec, 1/16" from case)	$T_L$	260	$^\circ\text{C}$

1. Difference in 4N32 and 4N33 is JEDEC Registration for VISO only. All Motorola 6-Pin devices exceed JEDEC specification and are 7500 Vac(pk). The same applies for 4N29 and 4N30.
2. Isolation surge voltage is an internal device dielectric breakdown rating. For this test, Pins 1 and 2 are common, and Pins 4, 5 and 6 are common.
3. Refer to Quality and Reliability Section in Opto Data Book for information on test conditions.

Preferred devices are Motorola recommended choices for future use and best overall value.

GlobalOptoisolator is a trademark of Motorola, Inc.

**4N29**  
**4N29A**

**4N30\***

[CTR = 100% Min]

**4N31**

[CTR = 50% Min]

**4N32\***

**4N33\***

[CTR = 500% Min]

\*Motorola Preferred Devices

### STYLE 1 PLASTIC

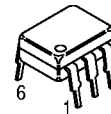

STANDARD THRU HOLE  
CASE 730A-04

### SCHEMATIC

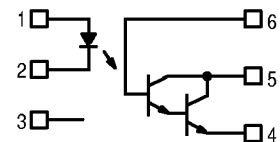

- PIN 1. LED ANODE  
2. LED CATHODE  
3. N.C.  
4. EMITTER  
5. COLLECTOR  
6. BASE

# 4N29 4N29A 4N30 4N31 4N32 4N33

## ELECTRICAL CHARACTERISTICS ( $T_A = 25^\circ\text{C}$ unless otherwise noted)<sup>(1)</sup>

Characteristic	Symbol	Min	Typ <sup>(1)</sup>	Max	Unit
<b>INPUT LED</b>					
*Reverse Leakage Current ( $V_R = 3\text{ V}$ , $R_L = 1\text{ M ohms}$ )	$I_R$	—	0.05	100	$\mu\text{A}$
*Forward Voltage ( $I_F = 10\text{ mA}$ )	$V_F$	—	1.34	1.5	Volts
Capacitance ( $V_R = 0\text{ V}$ , $f = 1\text{ MHz}$ )	$C$	—	1.8	—	$\text{pF}$

## OUTPUT DETECTOR ( $T_A = 25^\circ\text{C}$ and $I_F = 0$ , unless otherwise noted)

*Collector–Emitter Dark Current ( $V_{CE} = 10\text{ V}$ , Base Open)	$I_{CEO}$	—	—	100	$\text{nA}$
*Collector–Base Breakdown Voltage ( $I_C = 100\ \mu\text{A}$ , $I_E = 0$ )	$V_{(BR)CBO}$	30	—	—	Volts
*Collector–Emitter Breakdown Voltage ( $I_C = 100\ \mu\text{A}$ , $I_B = 0$ )	$V_{(BR)CEO}$	30	—	—	Volts
*Emitter–Collector Breakdown Voltage ( $I_E = 100\ \mu\text{A}$ , $I_B = 0$ )	$V_{(BR)ECO}$	5	—	—	Volts
DC Current Gain ( $V_{CE} = 5\text{ V}$ , $I_C = 500\ \mu\text{A}$ )	$h_{FE}$	—	16K	—	—

## COUPLED ( $T_A = 25^\circ\text{C}$ unless otherwise noted)

*Collector Output Current <sup>(3)</sup> ( $V_{CE} = 10\text{ V}$ , $I_F = 10\text{ mA}$ )	4N32, 4N33 4N29, 4N30 4N31	$I_C$ (CTR) <sup>(2)</sup>	50 (500) 10 (100) 5 (50)	— — —	— — —	$\text{mA} (\%)$
Isolation Surge Voltage <sup>(4,5)</sup> (60 Hz ac Peak, 1 Second)	4N29/A, 4N30, 31, 32, 33 *4N29, 4N32 *4N30, 4N31, 4N33	$V_{ISO}$	7500 2500 1500	— — —	— — —	$\text{Vac}(\text{pk})$
Isolation Resistance <sup>(4)</sup> ( $V = 500\text{ V}$ )		$R_{ISO}$	—	$10^{11}$	—	Ohms
*Collector–Emitter Saturation Voltage <sup>(3)</sup> ( $I_C = 2\text{ mA}$ , $I_F = 8\text{ mA}$ )	4N31 4N29, 4N30, 4N32, 4N33	$V_{CE(\text{sat})}$	— —	— —	1.2 1	Volts
Isolation Capacitance <sup>(4)</sup> ( $V = 0\text{ V}$ , $f = 1\text{ MHz}$ )		$C_{ISO}$	—	0.2	—	$\text{pF}$
Turn–On Time <sup>(6)</sup> ( $I_C = 50\text{ mA}$ , $I_F = 200\text{ mA}$ , $V_{CC} = 10\text{ V}$ )		$t_{on}$	—	0.6	5	$\mu\text{s}$
Turn–Off Time <sup>(6)</sup> ( $I_C = 50\text{ mA}$ , $I_F = 200\text{ mA}$ , $V_{CC} = 10\text{ V}$ )	4N29, 30, 31 4N32, 33	$t_{off}$	— —	17 45	40 100	$\mu\text{s}$

\* Indicates JEDEC Registered Data. All Motorola 6–pin devices have  $V_{ISO}$  rating of 7500  $\text{Vac}(\text{pk})$ .

1. Always design to the specified minimum/maximum electrical limits (where applicable).
2. Current Transfer Ratio (CTR) =  $I_C/I_F \times 100\%$ .
3. Pulse Test: Pulse Width = 300  $\mu\text{s}$ , Duty Cycle  $\leq 2\%$ .
4. For this test, Pins 1 and 2 are common and Pins 4, 5 and 6 are common.
5. Isolation Surge Voltage,  $V_{ISO}$ , is an internal device dielectric breakdown rating.
6. For test circuit setup and waveforms, refer to Figure 11.

TYPICAL CHARACTERISTICS

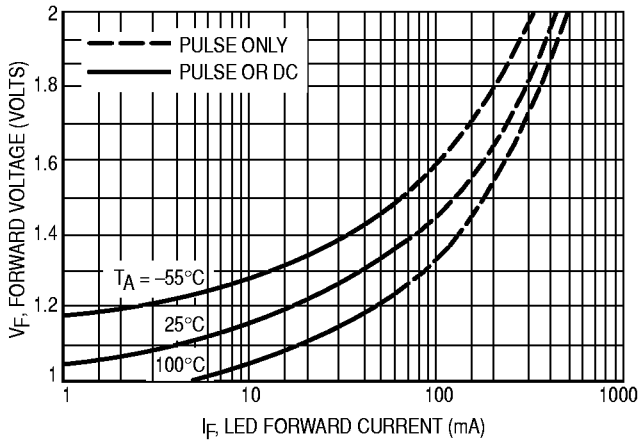

Figure 1. LED Forward Voltage versus Forward Current

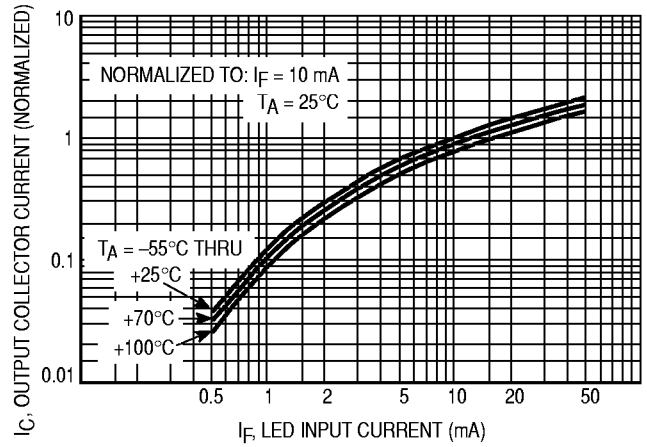

Figure 2. Output Current versus Input Current

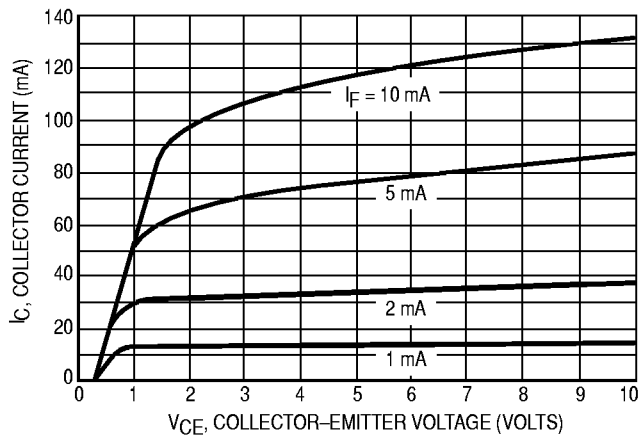

Figure 3. Collector Current versus Collector-Emitter Voltage

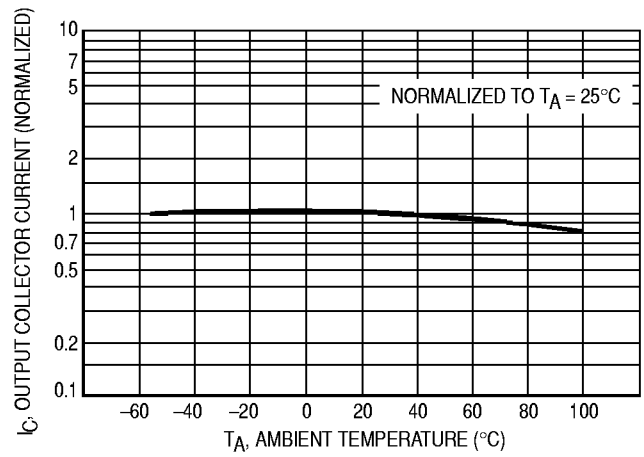

Figure 4. Output Current versus Ambient Temperature

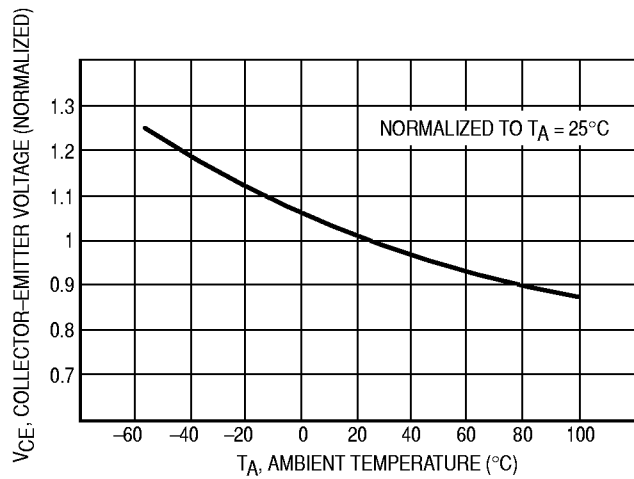

Figure 5. Collector-Emitter Voltage versus Ambient Temperature

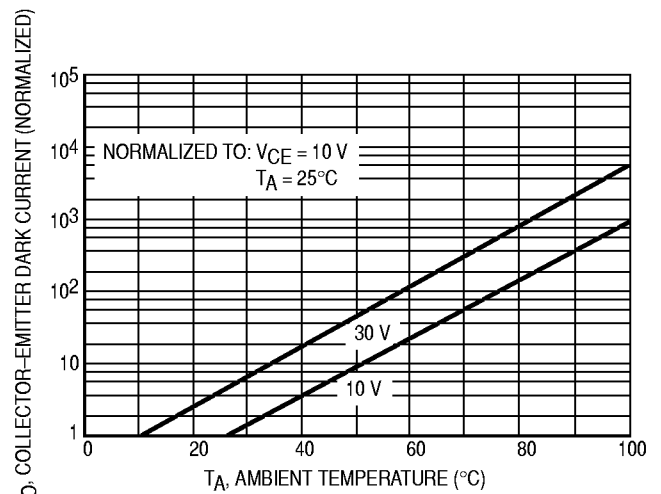

Figure 6. Collector-Emitter Dark Current versus Ambient Temperature

# 4N29 4N29A 4N30 4N31 4N32 4N33

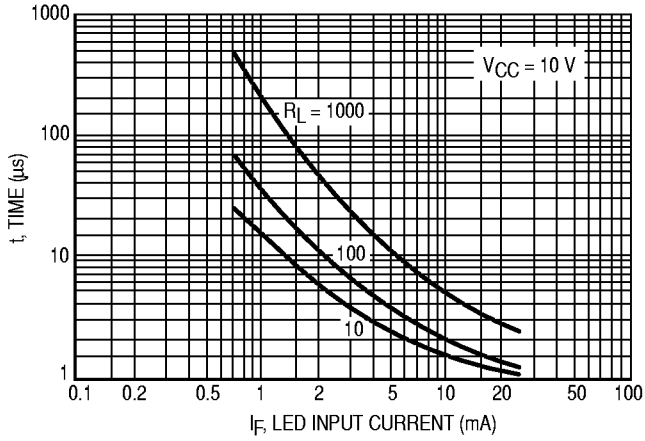

Figure 7. Turn-On Switching Times

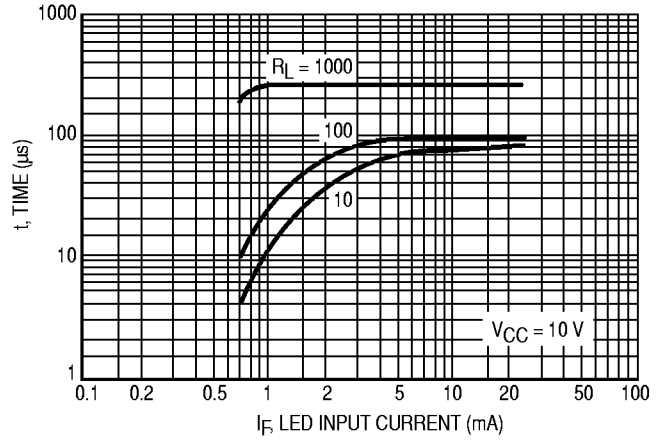

Figure 8. Turn-Off Switching Times

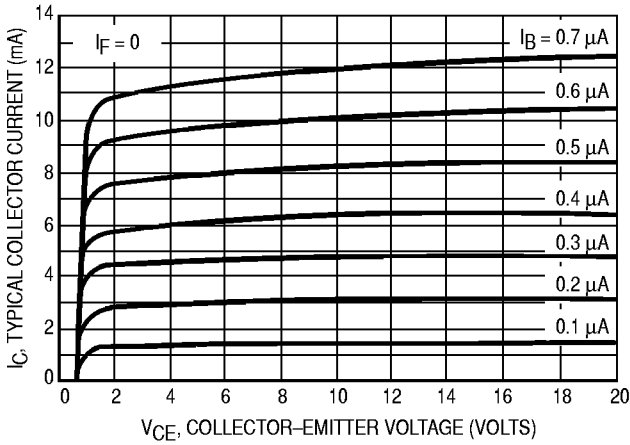

Figure 9. DC Current Gain (Detector Only)

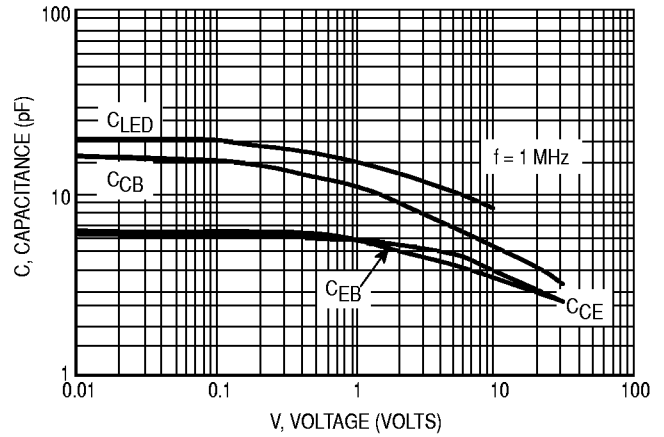

Figure 10. Capacitances versus Voltage

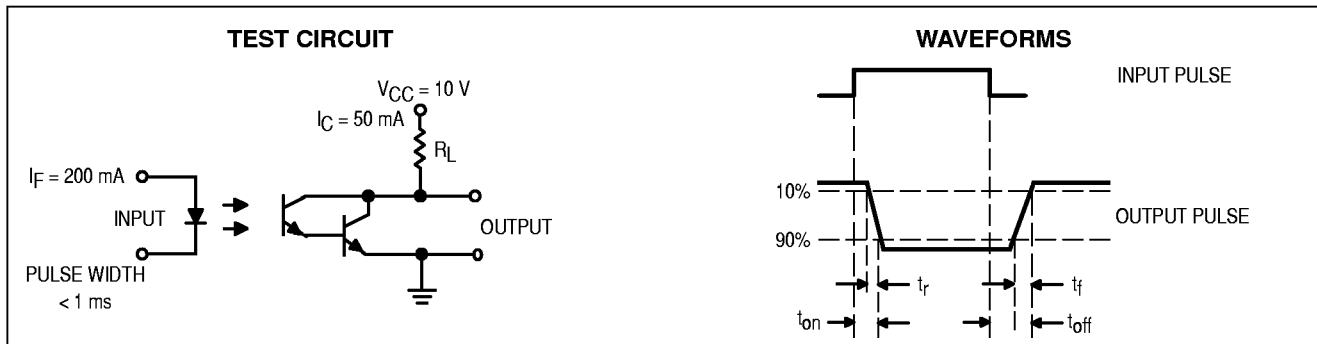
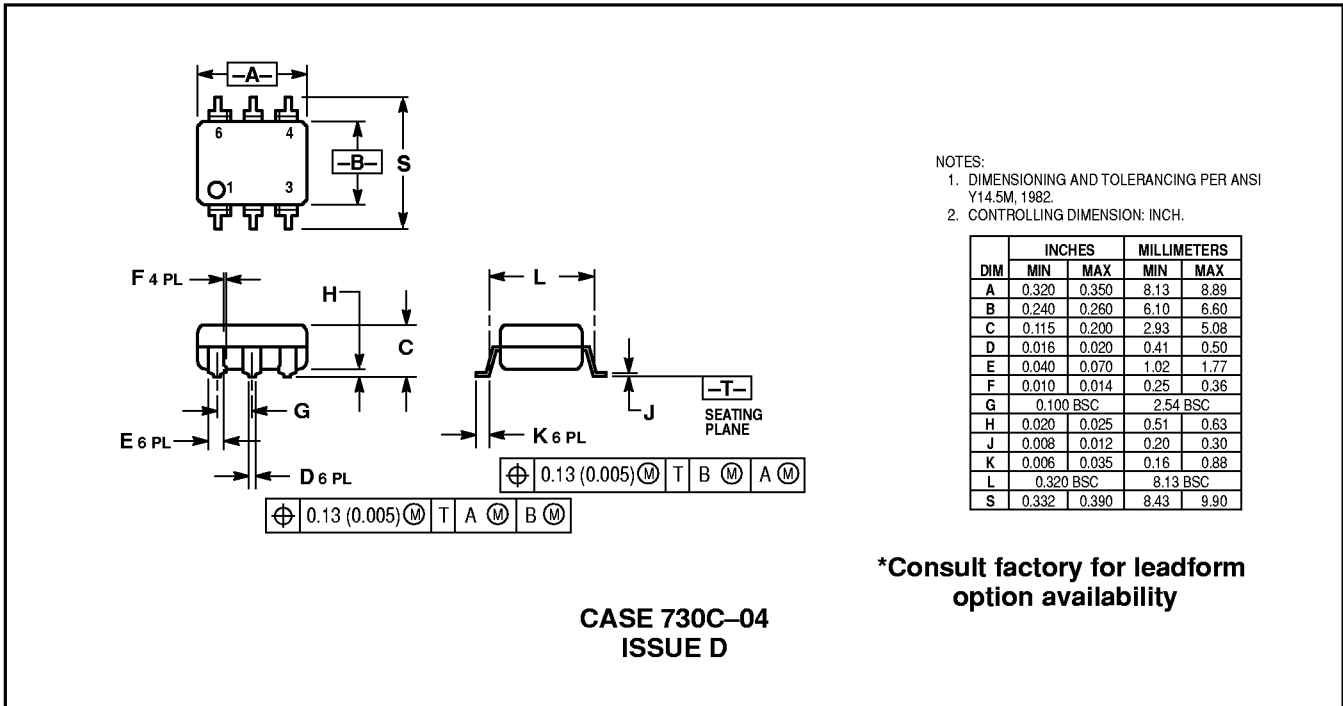
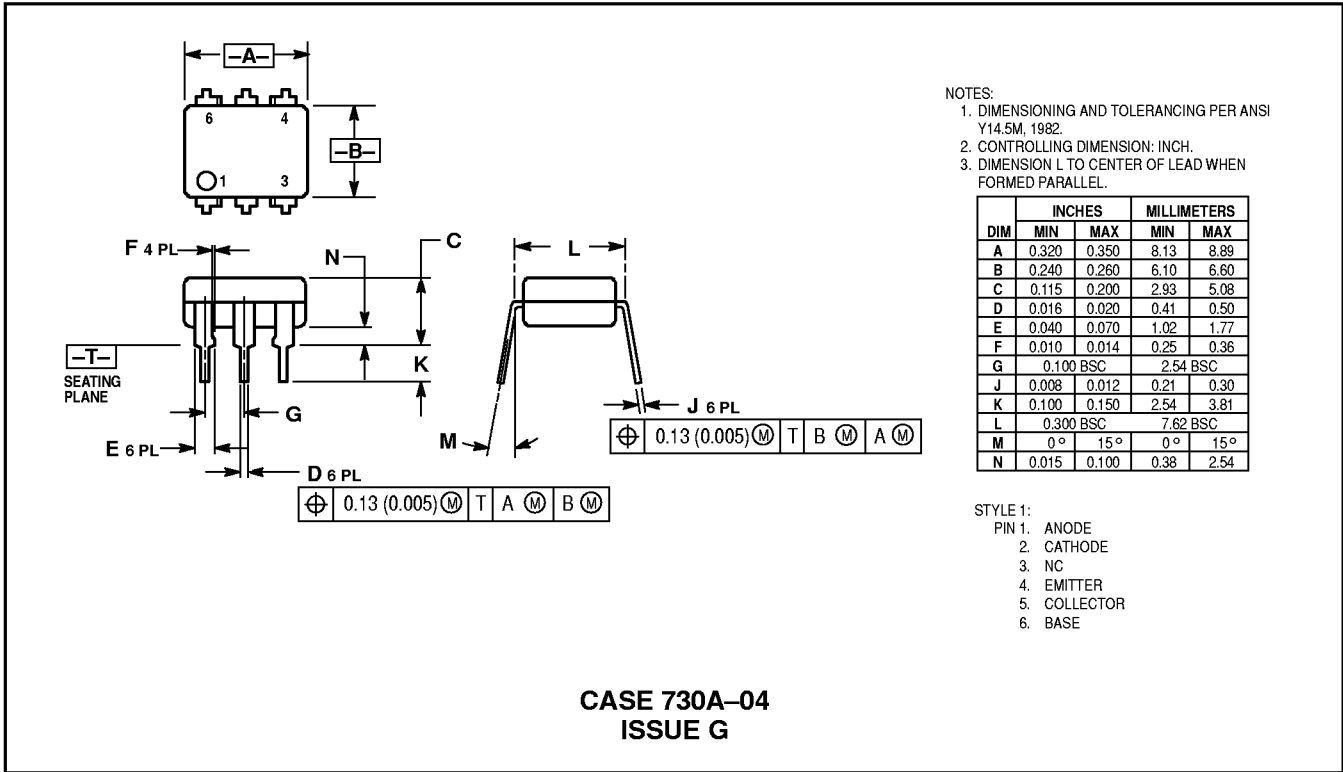

Figure 11. Switching Time Test Circuit and Waveforms

# 4N29 4N29A 4N30 4N31 4N32 4N33

## PACKAGE DIMENSIONS



# 4N29 4N29A 4N30 4N31 4N32 4N33

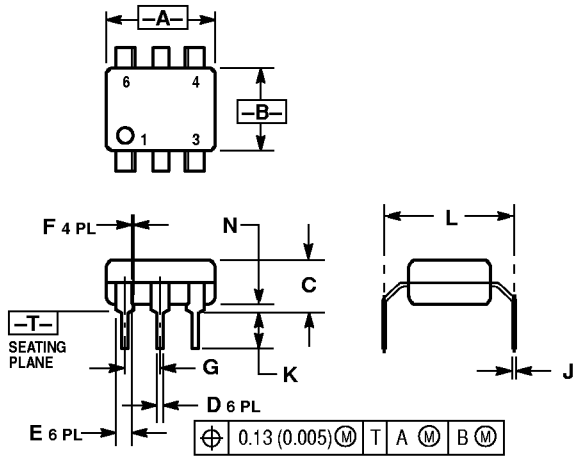

- NOTES:
1. DIMENSIONING AND TOLERANCING PER ANSI Y14.5M, 1982.
  2. CONTROLLING DIMENSION: INCH.
  3. DIMENSION L TO CENTER OF LEAD WHEN FORMED PARALLEL.

DIM	INCHES		MILLIMETERS	
	MIN	MAX	MIN	MAX
A	0.320	0.350	8.13	8.89
B	0.240	0.260	6.10	6.60
C	0.115	0.200	2.93	5.08
D	0.016	0.020	0.41	0.50
E	0.040	0.070	1.02	1.77
F	0.010	0.014	0.25	0.36
G	0.100 BSC		2.54 BSC	
J	0.008	0.012	0.21	0.30
K	0.100	0.150	2.54	3.81
L	0.400	0.425	10.16	10.80
N	0.015	0.040	0.38	1.02

**\*Consult factory for leadform option availability**

**CASE 730D-05  
ISSUE D**

Motorola reserves the right to make changes without further notice to any products herein. Motorola makes no warranty, representation or guarantee regarding the suitability of its products for any particular purpose, nor does Motorola assume any liability arising out of the application or use of any product or circuit, and specifically disclaims any and all liability, including without limitation consequential or incidental damages. "Typical" parameters can and do vary in different applications. All operating parameters, including "Typicals" must be validated for each customer application by customer's technical experts. Motorola does not convey any license under its patent rights nor the rights of others. Motorola products are not designed, intended, or authorized for use as components in systems intended for surgical implant into the body, or other applications intended to support or sustain life, or for any other application in which the failure of the Motorola product could create a situation where personal injury or death may occur. Should Buyer purchase or use Motorola products for any such unintended or unauthorized application, Buyer shall indemnify and hold Motorola and its officers, employees, subsidiaries, affiliates, and distributors harmless against all claims, costs, damages, and expenses, and reasonable attorney fees arising out of, directly or indirectly, any claim of personal injury or death associated with such unintended or unauthorized use, even if such claim alleges that Motorola was negligent regarding the design or manufacture of the part. Motorola and (M) are registered trademarks of Motorola, Inc. Motorola, Inc. is an Equal Opportunity/Affirmative Action Employer.

**How to reach us:**  
**USA / EUROPE:** Motorola Literature Distribution; P.O. Box 20912; Phoenix, Arizona 85036. 1-800-441-2447  
**JAPAN:** Nippon Motorola Ltd.; Tatsumi-SPD-JLDC, Toshikatsu Otsuki, 6F Seibu-Butsuryu-Center, 3-14-2 Tatsumi Koto-Ku, Tokyo 135, Japan. 03-3521-8315  
**MFAX:** RMFAX0@email.sps.mot.com - TOUCHTONE (602) 244-6609  
**HONG KONG:** Motorola Semiconductors H.K. Ltd.; 8B Tai Ping Industrial Park, 51 Ting Kok Road, Tai Po, N.T., Hong Kong. 852-26629298  
**INTERNET:** http://Design-NET.com

