



## Product Preview

# OCTAL TRANSCEIVER/REGISTER WITH 3-STATE OUTPUTS

These devices consist of bus transceiver circuits with 3-state D-type flip-flops, and control circuitry arranged for multiplexed transmission of data directly from the input bus or from the internal registers. Data on the A or B bus will be clocked into the registers as the appropriate clock pin goes to a high logic level. Output Enable (OE) and DIR pins are provided to control the transceiver function. In the transceiver mode, data present at the high impedance port may be stored in either the A or the B register or in both. The select controls can multiplex stored and real-time (transparent mode) data. The direction control determines which bus will receive data when the enable OE is Active LOW. In the isolation mode (OE HIGH), A data may be stored in the B register and/or B data may be stored in the A register.

- Independent Registers for A and B
- Multiplexed Real-Time and Stored Data
- Choice of True (F646) and Inverting (F648) Data Paths
- 3-State Outputs

### PIN ASSIGNMENTS

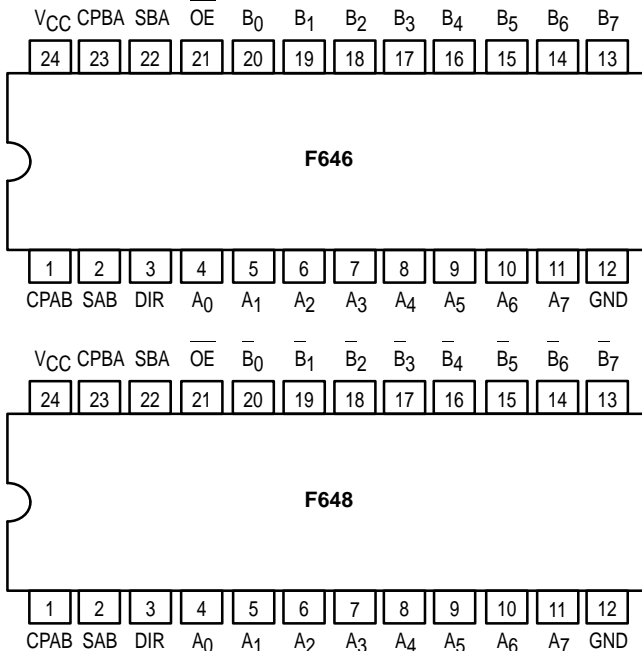

### LOGIC SYMBOLS

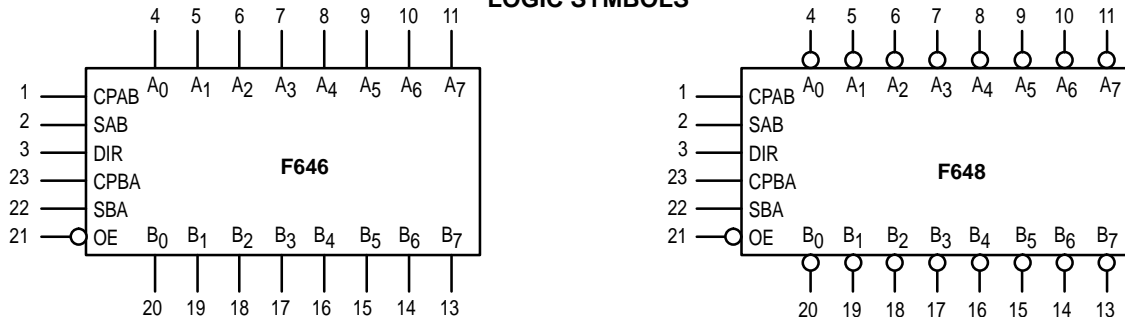

**MC54/74F646**  
**MC54/74F648**

**OCTAL TRANSCEIVER/REGISTER WITH 3-STATE OUTPUTS**

**FAST™ SCHOTTKY TTL**

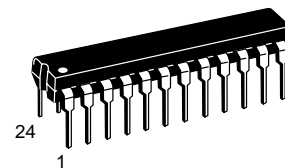

**J SUFFIX**  
CERAMIC  
CASE 758-01

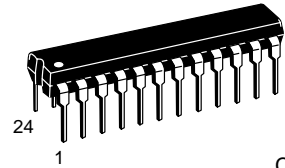

**N SUFFIX**  
PLASTIC  
CASE 724-03

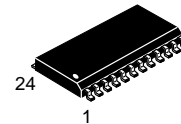

**DW SUFFIX**  
SOIC  
CASE 751E-03

### ORDERING INFORMATION

MC54FXXXJ Ceramic  
MC74FXXXN Plastic  
MC74FXXXDW SOIC

LIFETIME BUY

LAST SHIP 30/09/99 LAST ORDER 31/03/99

# MC54/74F646 • MC54/74F648

**FUNCTION TABLE**

Inputs						Data I/O*		Operation/Function
OE bar	DIR	CPAB	CPBA	SAB	SBA	A <sub>0</sub> -A <sub>7</sub>	B <sub>0</sub> -B <sub>7</sub>	
H	X	H or L	H or L	X	X	Input	Input	Isolation
H	X	↑	X	X	X	Input	Input	Store A <sub>n</sub> Data in A Register
H	X	X	↑	X	X	Input	Input	Store B <sub>n</sub> Data in B Register
H	X	↑	↑	X	X	Input	Input	Store A <sub>n</sub> /B <sub>n</sub> Data in A/B Register
L	H	X	X	L	X	Input	Output	A <sub>n</sub> to B <sub>n</sub> — Real Time (Transparent Mode)
L	H	↑	X	L	X	Input	Output	Store A <sub>n</sub> Data in A Register
L	H	H or L	X	H	X	Input	Output	A Register to B <sub>n</sub> (Stored Mode)
L	H	↑	X	H	X	Input	Output	Clock A <sub>n</sub> Data to B <sub>n</sub> and into A Register
L	L	X	X	X	L	Output	Input	B <sub>n</sub> to A <sub>n</sub> — Real Time (Transparent Mode)
L	L	X	↑	X	L	Output	Input	Store B <sub>n</sub> Data in B Register
L	L	X	H or L	X	H	Output	Input	B Register to A <sub>n</sub> (Stored Mode)
L	L	X	↑	X	H	Output	Input	Clock A <sub>n</sub> Data to B <sub>n</sub> and into B Register

\*The data output function may be enabled or disabled by various signals at the OE bar and DIR inputs. Data input functions are always enabled; i.e., data at the bus pins will be stored on every low-to-high transition of the appropriate clock inputs.

H = HIGH voltage level  
 L = LOW voltage level  
 X = Don't Care  
 ↑ = Low-to-High transition

**GUARANTEED OPERATING RANGES**

Symbol	Parameter		Min	Typ	Max	Unit
V <sub>CC</sub>	DC Supply Voltage	54, 74	4.5	5.0	5.5	V
T <sub>A</sub>	Operating Ambient Temperature Range	54 74	-55 0	25 25	125 70	°C
I <sub>OH</sub>	Output Current — High	54 74	— —	— —	-12 -15	mA
I <sub>OL</sub>	Output Current — Low	54 74	— —	— —	48 64	mA

LIFETIME BUY

LAST SHIP 30/09/99 LAST ORDER 31/03/99

MC54/74F646 • MC54/74F648

LOGIC DIAGRAM  
F646

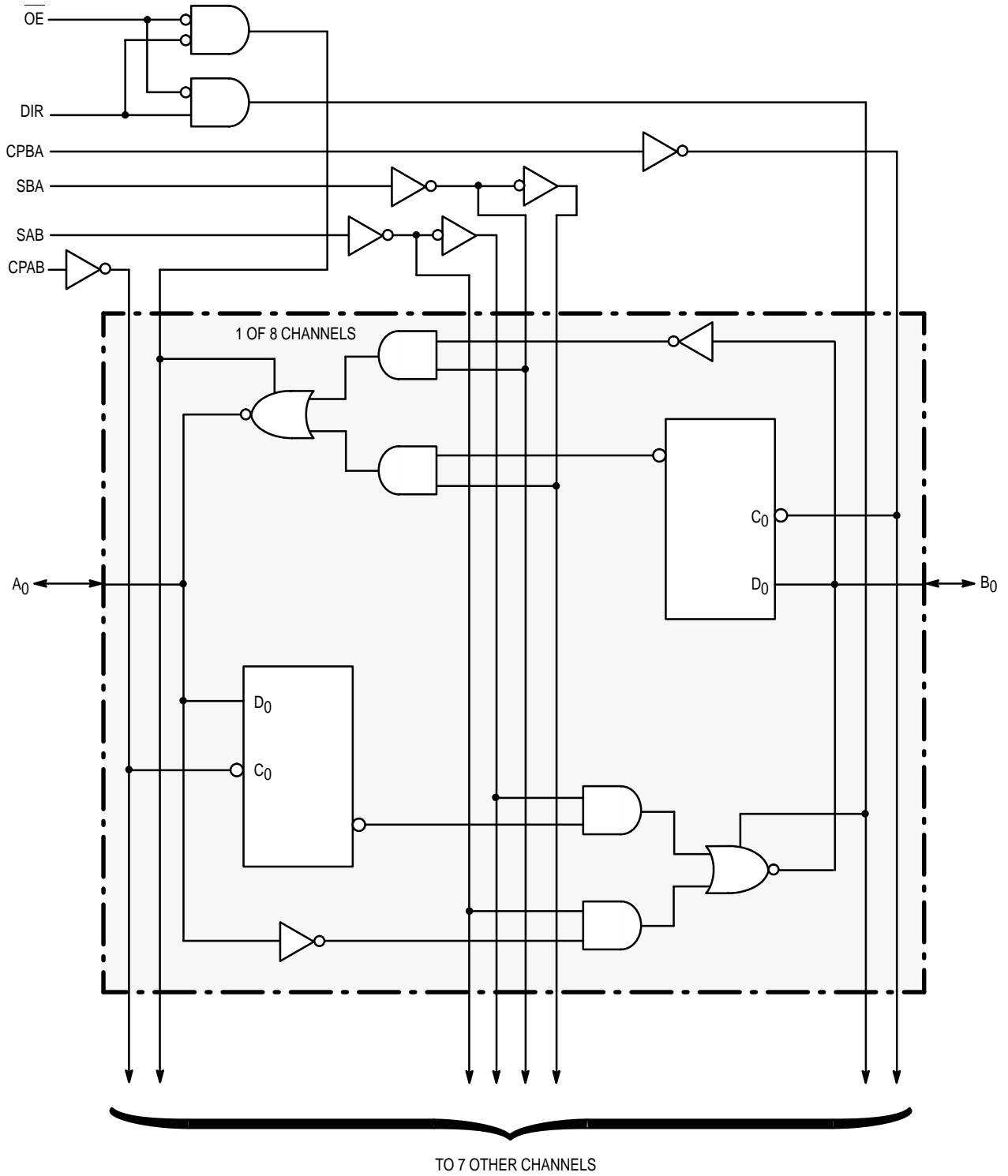

LIFETIME BUY

LAST ORDER 31/03/99 LAST SHIP 30/09/99

MC54/74F646 • MC54/74F648

LOGIC DIAGRAM  
F648

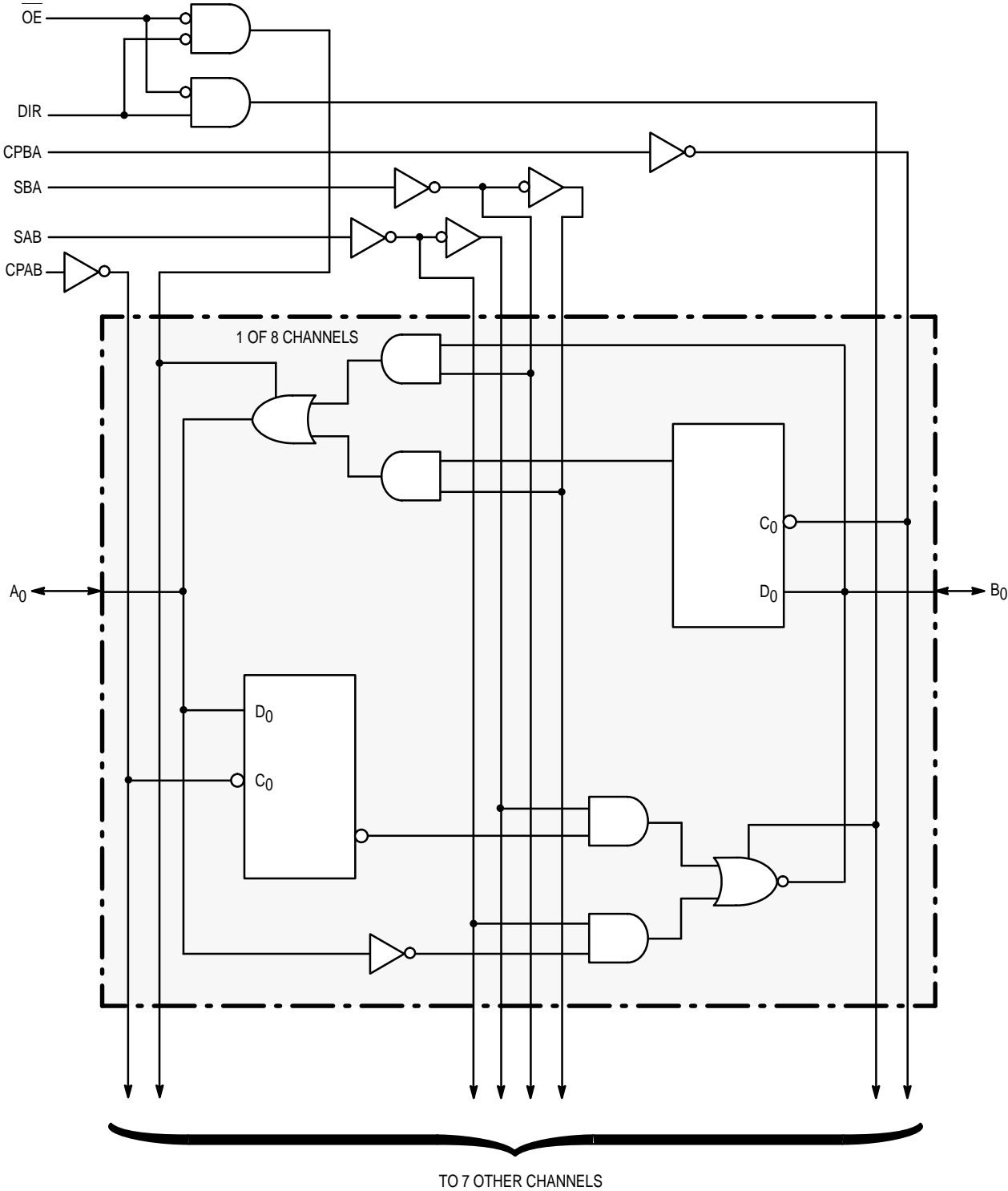

LIFETIME BUY

LAST SHIP 30/09/99  
LAST ORDER 31/03/99

# MC54/74F646 • MC54/74F648

## DC CHARACTERISTICS OVER OPERATING TEMPERATURE RANGE (unless otherwise specified)

Symbol	Parameter		Limits			Unit	Test Conditions (Note 1)		
			Min	Typ	Max				
V <sub>IH</sub>	Input HIGH Voltage		2.0	—	—	V	Guaranteed as a HIGH Signal		
V <sub>IL</sub>	Input LOW Voltage		—	—	0.8	V	Guaranteed as a LOW Signal		
V <sub>IK</sub>	Input Clamp Diode Voltage		—	—	-1.2	V	V <sub>CC</sub> = MIN, I <sub>IN</sub> = -18 mA		
V <sub>OH</sub>	Output HIGH Voltage	A <sub>n</sub> , B <sub>n</sub>	54/74	2.4	—	—	V	I <sub>OH</sub> = -3.0 mA	V <sub>CC</sub> = 4.5 V
			74	2.7	—	—	V	I <sub>OH</sub> = -3.0 mA	V <sub>CC</sub> = 4.75 V
			54	2.0	—	—	V	I <sub>OH</sub> = -12.0 mA	V <sub>CC</sub> = 4.5 V
			74	2.0	—	—	V	I <sub>OH</sub> = -15.0 mA	V <sub>CC</sub> = 4.5 V
V <sub>OL</sub>	Output LOW Voltage	A <sub>n</sub> , B <sub>n</sub>	54	—	—	0.55	V	I <sub>OL</sub> = 48 mA	V <sub>CC</sub> = MIN
			74	—	—	0.55	V	I <sub>OL</sub> = 64 mA	V <sub>CC</sub> = MIN
I <sub>IH</sub>	Input HIGH Current		Non I/O Pins	—	—	20	μA	V <sub>CC</sub> = MAX, V <sub>IN</sub> = 2.7 V	
			Non I/O Pins	—	—	100	μA	V <sub>CC</sub> = MAX, V <sub>IN</sub> = 7.0 V	
			I/O (A <sub>a</sub> , B <sub>n</sub> )	—	—	1.0	mA	V <sub>CC</sub> = MAX, V <sub>IN</sub> = 5.5 V	
I <sub>IL</sub>	Input LOW Current		Non I/O Pins	—	—	-600	μA	V <sub>CC</sub> = MAX, V <sub>IN</sub> = 0.5 V	
I <sub>IH</sub> + I <sub>OZH</sub>	Output Leakage Current		I/O (A <sub>n</sub> , B <sub>n</sub> )	—	—	70	μA	V <sub>CC</sub> = MAX, V <sub>OUT</sub> = 2.7 V	
I <sub>IL</sub> + I <sub>OZL</sub>	Output Leakage Current		I/O (A <sub>n</sub> , B <sub>n</sub> )	—	—	-650	μA	V <sub>CC</sub> = MAX, V <sub>OUT</sub> = 0.5 V	
I <sub>OS</sub>	Output Short Circuit Current (Note 2)		-100	—	-225	mA	V <sub>CC</sub> = MAX, V <sub>OUT</sub> = GND		
I <sub>CC</sub>	Power Supply Current		I <sub>CC</sub> H	—	—	135	mA	V <sub>out</sub> = HIGH	V <sub>CC</sub> = MAX
			I <sub>CC</sub> L	—	—	150		V <sub>out</sub> = LOW	
			I <sub>CC</sub> Z	—	—	150		V <sub>out</sub> = HIGH Z	

**NOTES:**

- For conditions shown as MIN or MAX, use the appropriate value specified under recommended operating conditions for the applicable device type.
- Not more than one output should be shorted at a time, nor for more than 1 second.

LIFETIME BUY

LAST SHIP 30/09/99  
LAST ORDER 31/03/99

MC54/74F646 • MC54/74F648

AC ELECTRICAL CHARACTERISTICS

Symbol	Parameter	54/74F		54F		74F		Unit
		T <sub>A</sub> = +25°C V <sub>CC</sub> = +5.0 V C <sub>L</sub> = 50 pF R <sub>L</sub> = 500 Ω		T <sub>A</sub> = -55°C to +125°C V <sub>CC</sub> = +5.0 V ±10% C <sub>L</sub> = 50 pF R <sub>L</sub> = 500 Ω		T <sub>A</sub> = 0°C to +70°C V <sub>CC</sub> = +5.0 V ±10% C <sub>L</sub> = 50 pF R <sub>L</sub> = 500 Ω		
		Min	Max	Min	Max	Min	Max	
f <sub>MAX</sub>	Maximum Clock Frequency	100	—	75	—	90	—	MHz
t <sub>PLH</sub> t <sub>PHL</sub>	Propagation Delay Clock to Bus	2.0 2.0	7.0 8.0	2.0 2.0	8.5 9.5	2.0 2.0	8.0 9.0	ns
t <sub>PLH</sub> t <sub>PHL</sub>	Propagation Delay Bus to Bus (F646)	1.0 1.0	7.0 6.5	1.0 1.0	8.0 8.0	1.0 1.0	7.5 7.0	ns
t <sub>PLH</sub> t <sub>PHL</sub>	Propagation Delay Bus to Bus (F648)	1.0 1.0	7.0 6.5	1.0 1.0	10.0 9.0	1.0 1.0	7.5 7.0	ns
t <sub>PLH</sub> t <sub>PHL</sub>	Propagation Delay SBA or SAB to A <sub>n</sub> or B <sub>n</sub>	2.0 2.0	7.5 7.5	2.0 2.0	10.0 10.0	2.0 2.0	9.0 9.0	ns
t <sub>PZH</sub> t <sub>PZL</sub>	Output Enable Time OE to A <sub>n</sub> or B <sub>n</sub>	2.0 2.0	7.0 7.0	2.0 2.0	9.5 9.5	2.0 2.0	8.5 8.5	ns
t <sub>PHZ</sub> t <sub>PLZ</sub>	Output Disable Time OE to A <sub>n</sub> or B <sub>n</sub>	1.0 2.0	7.0 7.0	1.0 2.0	9.5 9.5	1.0 2.0	8.5 8.5	ns
t <sub>PZH</sub> t <sub>PZL</sub>	Output Enable Time DIR to A <sub>n</sub> or B <sub>n</sub>	2.0 2.0	7.0 7.0	2.0 2.0	9.5 9.5	2.0 2.0	8.5 8.5	ns
t <sub>PHZ</sub> t <sub>PLZ</sub>	Output Disable Time DIR to A <sub>n</sub> or B <sub>n</sub>	1.0 2.0	7.0 7.0	1.0 2.0	9.5 9.5	1.0 2.0	8.5 8.5	ns

AC OPERATING REQUIREMENTS

Symbol	Parameter	54/74F		54F		74F		Unit
		T <sub>A</sub> = +25°C V <sub>CC</sub> = +5.0 V C <sub>L</sub> = 50 pF R <sub>L</sub> = 500 Ω		T <sub>A</sub> = -55°C to +125°C V <sub>CC</sub> = +5.0 V ±10% C <sub>L</sub> = 50 pF R <sub>L</sub> = 500 Ω		T <sub>A</sub> = 0°C to +70°C V <sub>CC</sub> = +5.0 V ±10% C <sub>L</sub> = 50 pF R <sub>L</sub> = 500 Ω		
		Min	Max	Min	Max	Min	Max	
t <sub>s(H)</sub> t <sub>s(L)</sub>	Setup Time, HIGH or LOW Bus to Clock	4.0 4.0	— —	5.0 5.0	— —	5.0 5.0	— —	ns
t <sub>h(H)</sub> t <sub>h(L)</sub>	Hold Time, HIGH or LOW Bus to Clock	0.0 0.0	— —	0.0 0.0	— —	0.0 0.0	— —	ns
t <sub>w(H)</sub> t <sub>w(L)</sub>	Clock Pulse Width HIGH or LOW	4.0 5.0	— —	4.0 5.0	— —	4.0 5.0	— —	ns

LIFETIME BUY

LAST SHIP 30/09/99  
LAST ORDER 31/03/99

LIFETIME BUY

LAST SHIP 30/09/99  
LAST ORDER 31/03/99

Mfax is a trademark of Motorola, Inc.

Motorola reserves the right to make changes without further notice to any products herein. Motorola makes no warranty, representation or guarantee regarding the suitability of its products for any particular purpose, nor does Motorola assume any liability arising out of the application or use of any product or circuit, and specifically disclaims any and all liability, including without limitation consequential or incidental damages. "Typical" parameters which may be provided in Motorola data sheets and/or specifications can and do vary in different applications and actual performance may vary over time. All operating parameters, including "Typicals" must be validated for each customer application by customer's technical experts. Motorola does not convey any license under its patent rights nor the rights of others. Motorola products are not designed, intended, or authorized for use as components in systems intended for surgical implant into the body, or other applications intended to support or sustain life, or for any other application in which the failure of the Motorola product could create a situation where personal injury or death may occur. Should Buyer purchase or use Motorola products for any such unintended or unauthorized application, Buyer shall indemnify and hold Motorola and its officers, employees, subsidiaries, affiliates, and distributors harmless against all claims, costs, damages, and expenses, and reasonable attorney fees arising out of, directly or indirectly, any claim of personal injury or death associated with such unintended or unauthorized use, even if such claim alleges that Motorola was negligent regarding the design or manufacture of the part. Motorola and  are registered trademarks of Motorola, Inc. Motorola, Inc. is an Equal Opportunity/Affirmative Action Employer.

**How to reach us:**

**USA/EUROPE/Locations Not Listed:** Motorola Literature Distribution; P.O. Box 5405, Denver, Colorado 80217.  
1-303-675-2140 or 1-800-441-2447

**JAPAN:** Motorola Japan Ltd.; SPS, Technical Information Center, 3-20-1, Minami-Azabu. Minato-ku, Tokyo 106-8573 Japan.  
81-3-3440-3569

**ASIA/PACIFIC:** Motorola Semiconductors H.K. Ltd.; Silicon Harbour Centre, 2 Dai King Street, Tai Po Industrial Estate, Tai Po, N.T., Hong Kong. 852-26668334

**Customer Focus Center: 1-800-521-6274**

**Mfax™:** RMFAX0@email.sps.mot.com – TOUCHTONE 1-602-244-6609  
Motorola Fax Back System – US & Canada ONLY 1-800-774-1848  
– http://sps.motorola.com/mfax/

**HOME PAGE:** http://motorola.com/sps/

