



TENTATIVE

LED DOT MATRIX MODULE

MODEL : KLM-162LxS

(x : Red, Green, Yellow)

광전자 주식회사

AUK CORP.

802- 12 Shinheung-Dong, Iksan, Korea TEL : (0653) 835-7111

FAX : (0653) 835-2681

URL : <http://www.auk.co.kr>

E-mail : webmaster@auk.co.kr

1. OVERVIEW

AUK has successfully developed a high brightness 16*16 LED dot matrix module. It is integrated with $\phi 5$ LED lamps. This module is compact, slim and light. It is suitable for the simple message board.

2. SPECIFICATION

ITEM	DESCRIPTION
Size(W×H×D)	96×96×30(mm)
Display Color	Red or Green or Yellow(one color)
Number of Dots	256(16×16)
Drive mode	Dynamic Drive(1/8 Duty)
Brightness Control	10 steps
Over Voltage Protection	Works at over 6V (Only LED Off)
Viewing Angle	Horizontal : $\pm 30^\circ$, Vertical $\pm 30^\circ$
Weight	200±5g

3. ELECTRICAL CHARACTERISTICS

1) ABSOLUTE MAXIMUM RATINGS($T_a=25^\circ\text{C}$)

ITEM		SYMBOL	RATING	UNIT
DC Supply Voltage	Circuit	Vcc1	6	V
	LED	Vcc2	5.25	V
Input Voltage	Circuit	Vin1	-0.3 to Vcc1 +0.3	V
	LED	Vin2	-0.3 to Vcc2	V
Current Consumption	Circuit	IC	0.1(Vcc=5V)	A
	LED	IL	1.3(Vcc=5V)	A
Clock Frequency		f	50	MHz
Operating Temperature		Topr	-25~45	$^\circ\text{C}$
Storage Temperature		Tstg	-25~85	$^\circ\text{C}$
Isolation Temperature		Viso	AC500V(10mA), 1Minute(connector~supporter)	

2) RECOMMENDABLE DRIVE CONDITIONS

ITEM		SYMBOL	RATING	UNIT
DC Supply Voltage	Circuit	Vcc1	4.75~5.25	V
	LED	Vcc2	4.75~5.25	V
Operating Temperature		Topr	0~40	$^\circ\text{C}$

4. OPTICAL CHARACTERISTIC

◆ MEASURE AREA : $\phi 95\text{mm}$
(Note 1)

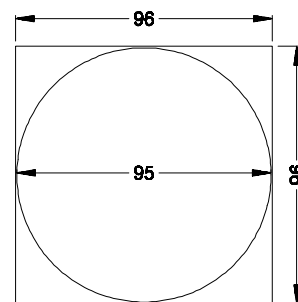

ITEM	SYMBOL	RATING			UNIT	
		MIN	TYP	MAX		
Luminous intensity	Red	LvR	(1700)	(2000)	(3470)	cd/m ² (nit), Note 1
	Green	LvG		(700)		"
	Yellow	LvY				"
Peak Emission Wavelength	Red	λ pR		630		nm
	Green	λ pG		567		nm
	Yellow	λ pY				"

5. INPUT LEVEL

ITEM	SYMBOL	MIN	TYP	MAX	UNIT
Input"L"	ViL	-	-	0.8	V
Input"H"	ViH	2.4	-	-	

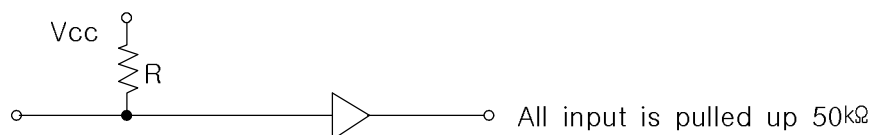

6.FUNCTION

ITEM	PIN NAME	FUNCTION DESCRIPTION	PIN NO.
Power Pin	Vcc1	Power supply for the circuit	1
	Vcc2	Power supply for the LED	3
	GND	Ground of the module	2
Data Pin	High Data	Data input for color	8
	Low Data	Data input for color	6
	Line Address(A0~A2)	Signal input for line address	9,10,11
	Clock (CLK)	Clock signal for Data input and display	4
	Latch	Signal input for Data latch (New Data Latch at Rising Edge)	2
	Out Enable (OE)	Display ON or OFF control ('H' Display OFF) ('L' Display ON)	1
	GND	Signal Ground	3,5,7
Brightness Control Switch	S/W1 ~ S/W4	Total brightness control of color	1,2,3,4

7. BLOCK DIAGRAM

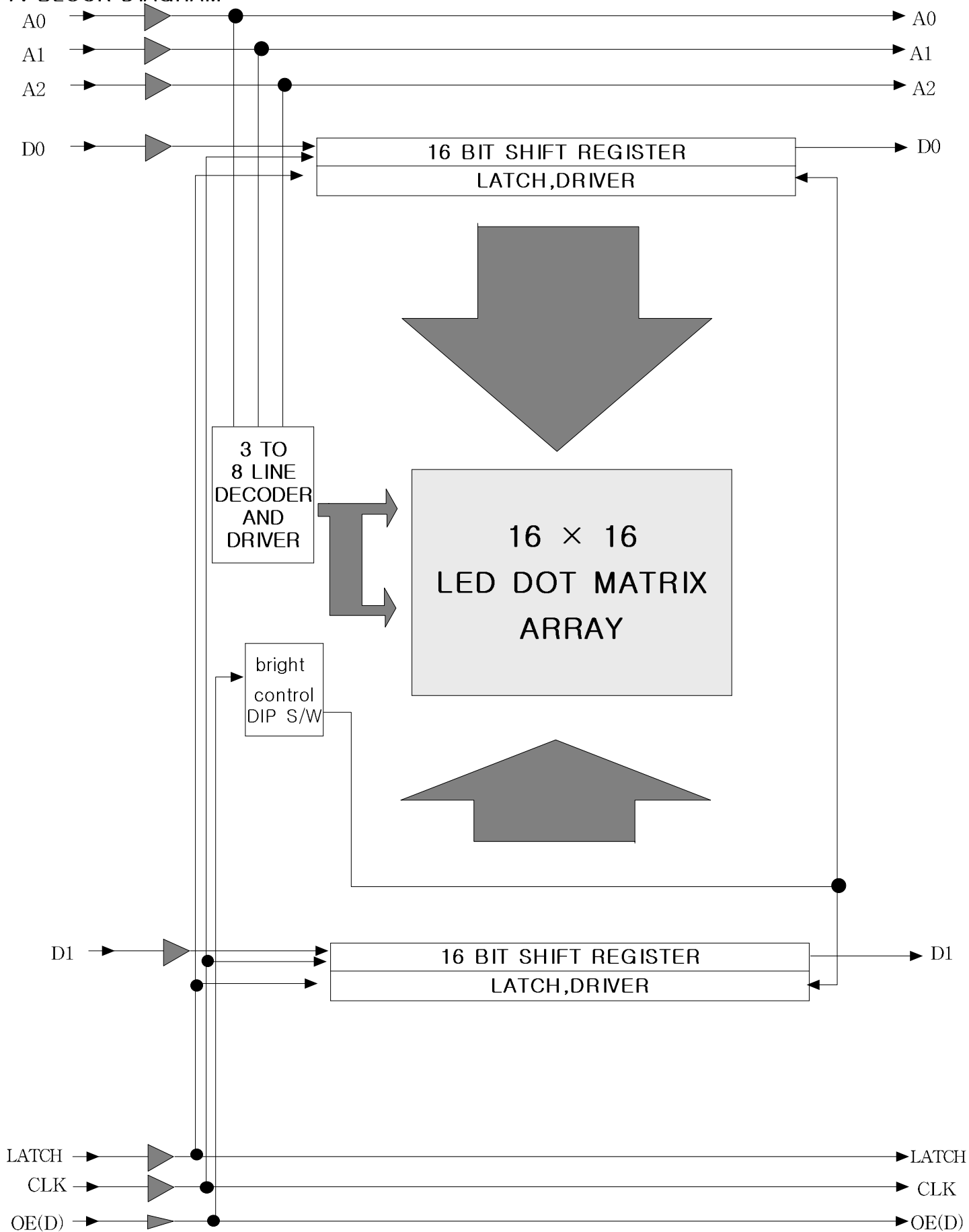

8. TIMING

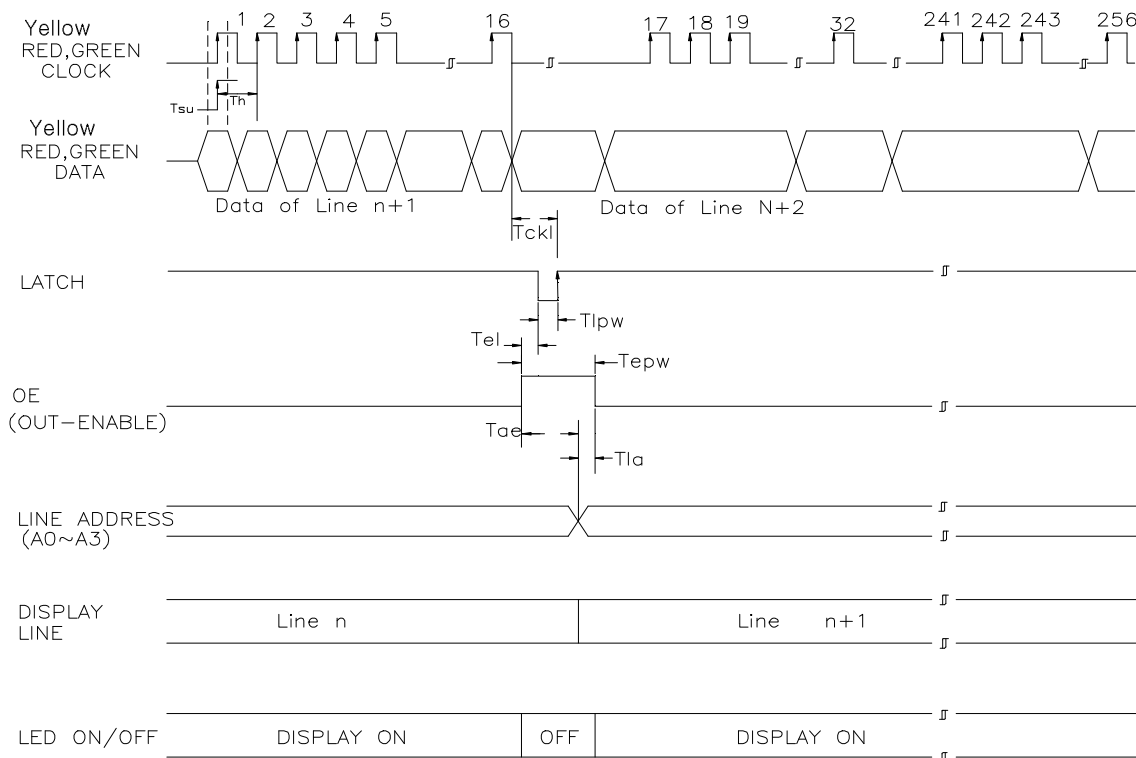

** when the Latch "L" or OE "H" => LED turn Off

■ OPERATING TIMING

($T_a=25^{\circ}C$, $V_{cc}=5V$)

NO	ITEM	SYMBOL	MIN	MAX	UNIT
1	Clock Cycle	T	—	50	MHz
2	Data Set up Time	Tsu	5	—	ns
3	Data Hold Time	Th	5	—	ns
4	Latch Pulse Width	Tpw	5	—	ns
5	Clock-Latch Time	Tckl	20	—	ns
6	Enable-Latch Time	Tel	3	—	μS
7	Enable Pulse Width	Tepw	3	—	μS
8	Address-Enable Time	Tae	1.5	—	μS
9	Latch-Address Time	Tla	1.5	—	μS

9. PIN CONNECTION & SWITCH

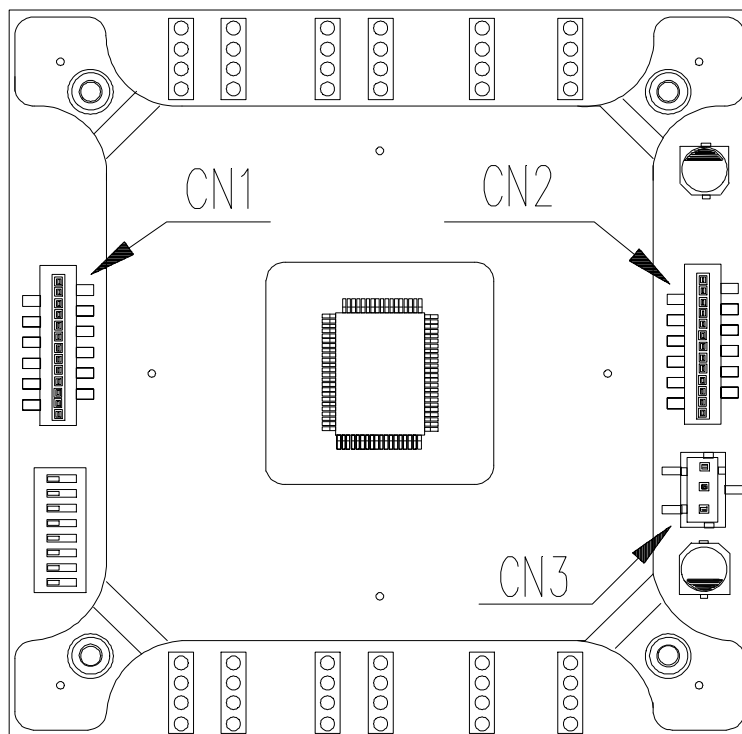

1) C.N-1 (DATA INPUT)

	PIN NO.	NAME
	1	OUT ENABLE
	2	LATCH
	3	GND
	4	CLK
	5	GND
	6	Low-Data
	7	GND
	8	High-DATA
	9	A0
	10	A1
	11	A2
	12	NC

2) C.N-2 (DATA OUTPUT)

	PIN NO.	NAME
	1	OUT ENABLE
	2	LATCH
	3	GND
	4	CLK
	5	GND
	6	Low-Data
	7	GND
	8	High-DATA
	9	A0
	10	A1
	11	A2
	12	NC

10. DIMENSION

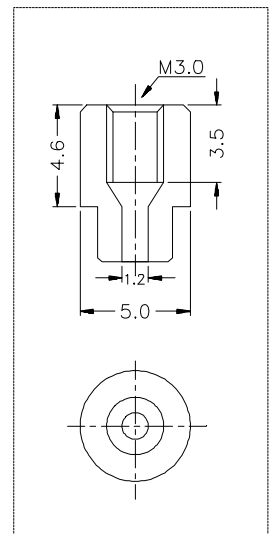
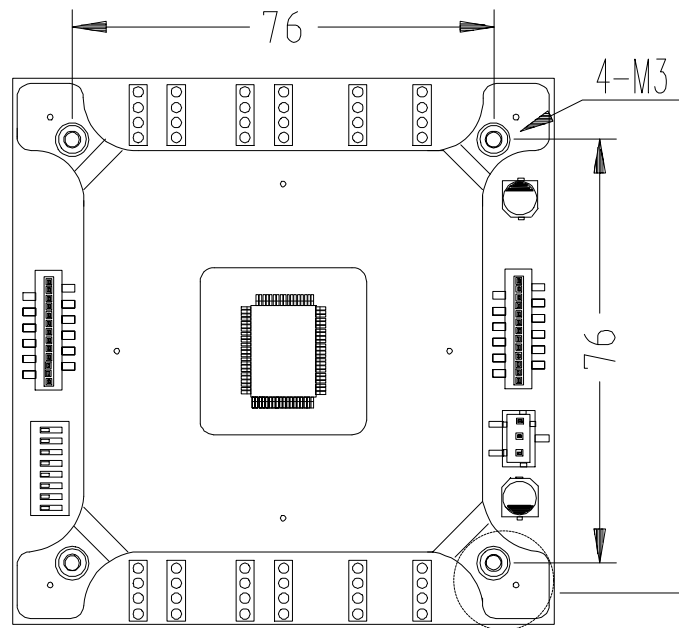
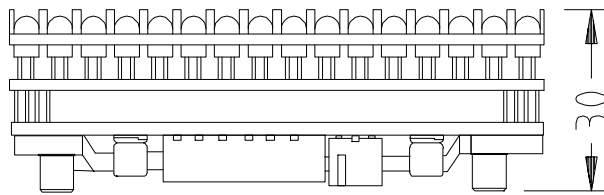
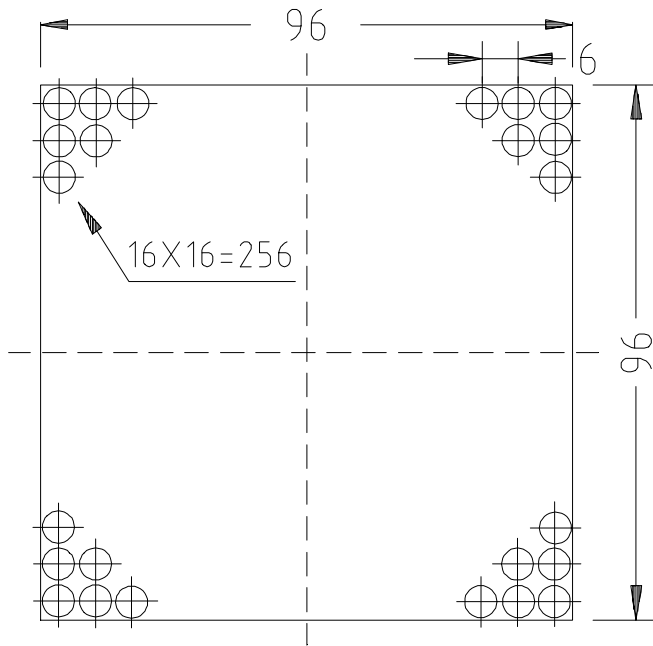

11. CONNECTION & CABLE (STANDARD)

1) C.N-1, C.N-2 (FFC CABLE)

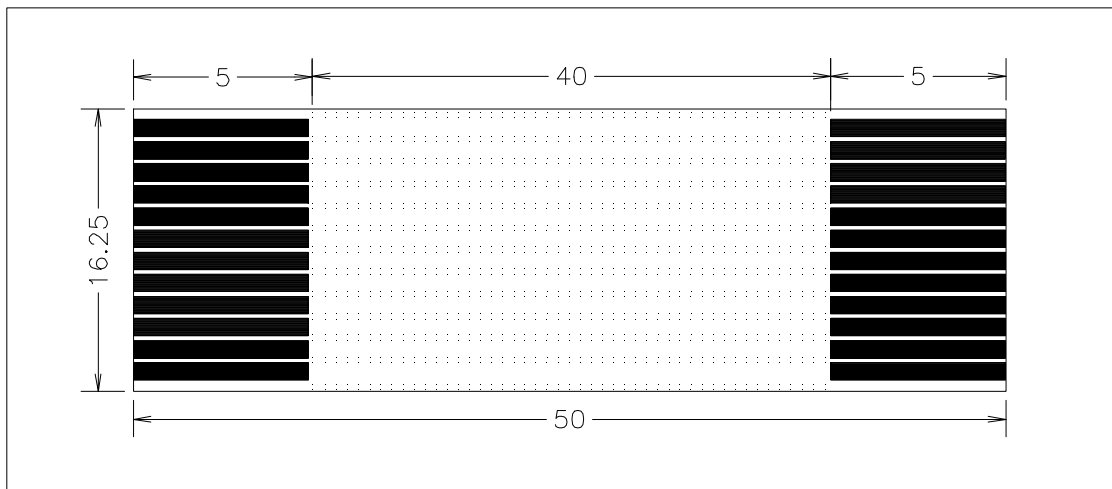

2) C.N-3 (POWER CABLE)

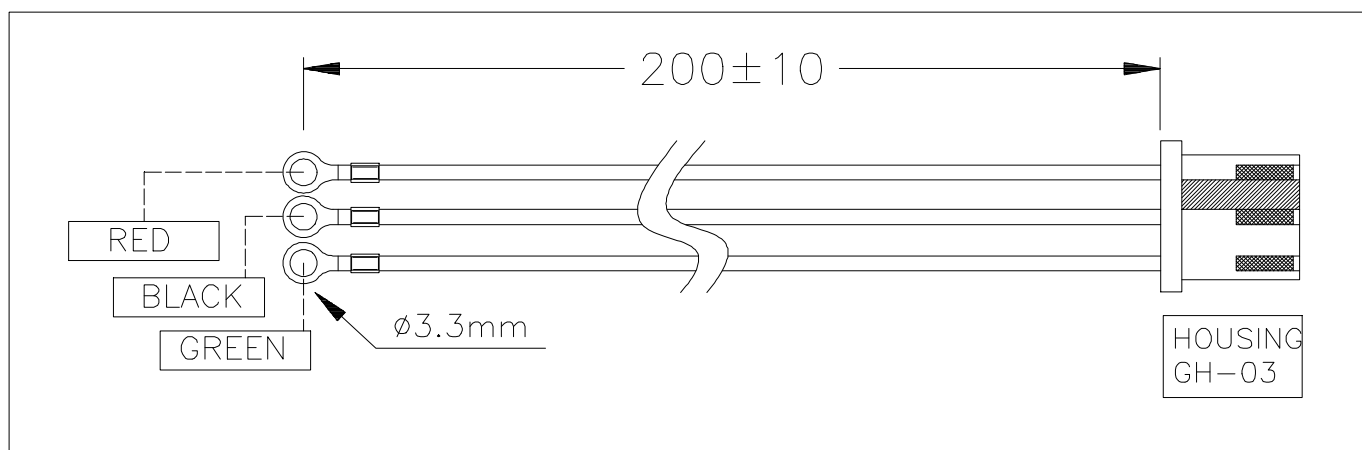

CONNECTION NO.	MODEL NO.	SPEC
C.N-1 , C.N-2	KF2B 12/50P7 S9 B9 :VS3 VB3	12P*50*1.25*7(0.1*0.8)
C.N-3	GH - 0322 - 200R	3P * 200mm

3) C.N-3 (POWER)

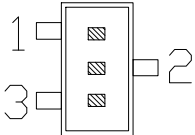
	PIN NO	NAME	LEVEL	FUNCTION
	1	Vcc1	5V	For the Circuit
	2	GND	0V	Ground
	3	Vcc2	5V	For the LED

4) BRIGHTNESS CONTROL SWITCH

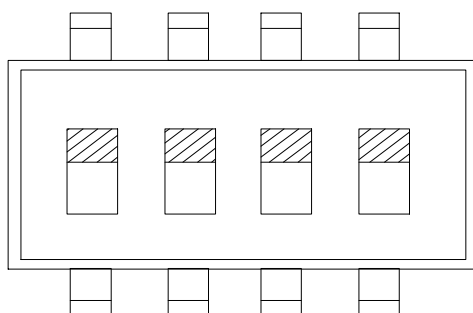

Bright Level	SWITCH POSITION			
	S/W1	S/W2	S/W3	S/W4
0	ON	ON	ON	ON
1	ON	ON	ON	OFF
2	ON	ON	OFF	ON
3	ON	ON	OFF	OFF
4	ON	OFF	ON	ON
5	ON	OFF	ON	OFF
6	ON	OFF	OFF	ON
7	ON	OFF	OFF	OFF
8	OFF	ON	ON	ON
9	OFF	ON	ON	OFF

**** Level 0 has the most brightness.**

12. The rate of Lits derating curve

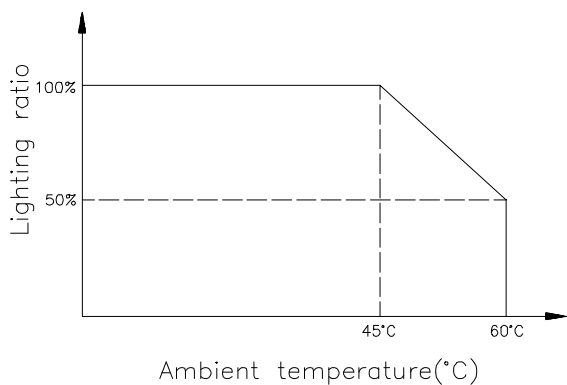

When you drive the module, refer to left graph.

13. Data Shift Direction

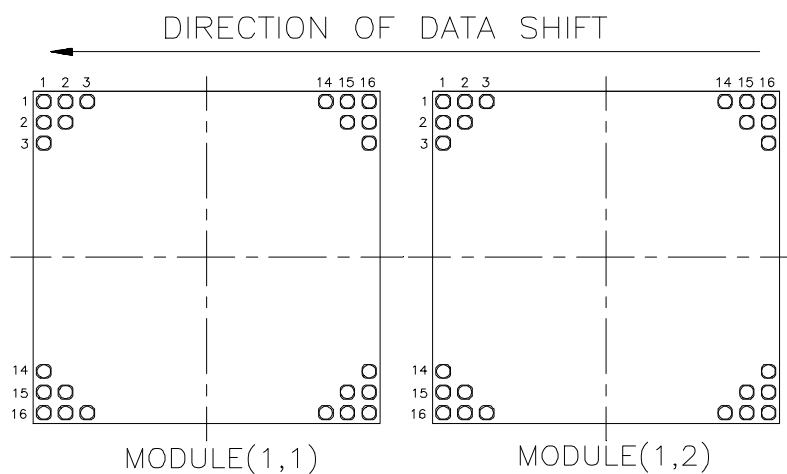

14. Example connection

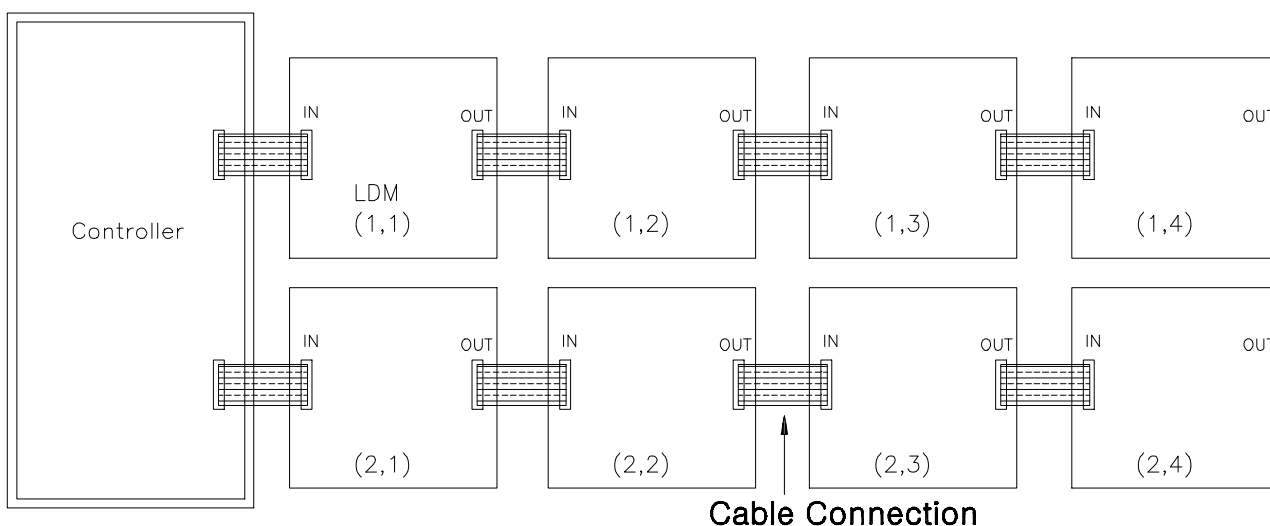

※ The above drawing shows the back side of LDM

15. Matter on caution when installed (assembly)

- 1) It should be installed deeply considered in noisy place because wrong operation might be occurred.
- 2) Make sure of power source before operating after being assembled module. Damage may be occurred by low voltage or short circuit.
- 3) The module is not waterproofed. so, do waterproof treatment to instrument if you need.
- 4) Please install module within guaranteed scope and specially escape installation from circumstance of smoke, dust, and SO₂-GAS.
- 5) Please turn off power source if there is no data transmission when you testing its operation after installation.
- 6) Please establish policy of heat release and use it under circumstance within guarantee scope in case a lot of module is assembled and used.
- 7) In case it is used under below zero circumstance, it is favorable to use it with high voltage within maximum extent of value of input power source.
- 8) Please make instrument after examining weight fully as module weight is 206g.

16. Matter of reference when handling.

- 1) Over voltage prevention circuit is built in "LED POWER SUPPLY (Vcc2)" of module and LED will be turned off in case high voltage is supplied beyond maximum extent of regular power.
- 2) Switch of brightness adjustment-use is adjusted in fixed rank by LOT and supplied therefore don't operate it as you please.
- 3) Operating circuit is composed of CMOS, so, please take caution for static electricity.
- 4) If you have any question for using this, please contact us.

Product warranty

Warranty contents

Exchange without compensation will be made for the period of 12 month after having been delivered in case troubles in ordinary treatment in occurred.

Warranty is for delivered products. Expense of exchange work, damage compensation for advertisement suspension is not paid. Also compensative treatment will be made in case of following even for warranty period.

- 1) Troubles by handling carelessness and wrong using.
- 2) Troubles by inapplicable repair or remarking.
- 3) Troubles by natural disaster.

◎ Matters that demand attention and notice in compliance with contents of this document and use of the product.

- (1) In case that the products mentioned in this document is applicable to foreign exchange and foreign control law, admission of korea government is required when exporting or taking out.
 - (2) Technical information mentioned in this document is record of production characteristics and practical circuit and it is not mean guarantee of possessive right of industry or permission of performance right.
 - (3) Standard use of this production – It is used for general electronic parts (indicators, Display, office machine measuring equipment and home consumer products). When it is used for specific use (Aviation space, Traffic equipment, Burning equipment and safety equipment, ETC) which special quality and reliability is required and when trouble or miss operation of these threaten human's life or do harm to person, you should discuss it with us in advance considering using except standard use of our intention.
 - (4) You should use it within the warranty scope for special maximum rating operation power source electronic voltage scope and heat release ability.
We are not responsible for the defect that occur to instrument when it is used beyond our warranty measures.
- ◎ If you have any question or change required about the specification, please solve it after agreement with us.