

3.3V SM HCMOS VCXO WITH TRI-STATE

SPECIFICATIONS	VKB51B5	VKB52B5	VKB53B5	VKB62B5	VKB63B5
Frequency Range	1.0MHz to 52MHz			1.0MHz to 45MHz	
Frequency Stability (See note 1)	±25ppm	±50ppm	±100ppm	±50ppm	±100ppm
Temperature Range	0°C to +70°C			-40°C to +85°C	
Waveform	TTL/HCMOS Squarewave				
Load	5TTL/15pF				
Output	Voltage	Voh			
		Vol			
	Current	Ioh			
		Iol			
Duty Cycle	45/55 Maximum @ 1.65V				
Rise/Fall Time	5nS Maximum				
Jitter	1.0ps RMS Maximum over 12kHz to 20MHz bandwidth 5.0ps RMS Maximum over 10Hz to 20MHz bandwidth				
Tri-State Input	Output E/D Time	150nS Typical			
	Enable (Vih)	2.7V Minimum			
	Disable (Vil)	0.3V Maximum			
Oscillator output is enabled with no connection on pin 5					
Frequency Control Input					
Pullability	±100ppm Minimum				
Control Voltage (Vc)	0.15Vdc to 3.15Vdc				
Slope	Positive				
Monotonic Linearity	< ±10%				
Input Impedance	50K ohms Nominal				
Modulation Bandwidth	10KHz Minimum				
Supply Voltage	+3.3Vdc ±0.3Vdc				
Supply Current	1.0 to 30 MHz, 15 mA Maximum 30 to 52 MHz, 25 mA Maximum				
Package	Hermetically sealed, leadless ceramic package				

NOTE 1- Inclusive of calibration tolerance at 25°C, operating temperature range, supply voltage change, load change, and aging, with Vc= 1.65Vdc.

NOTE 2- A bypass capacitor of .01uF must be used between Vdd and Gnd.

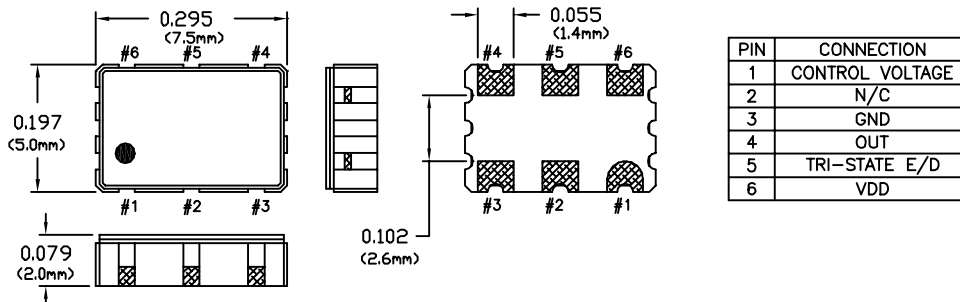

OUTPUT WAVEFORM

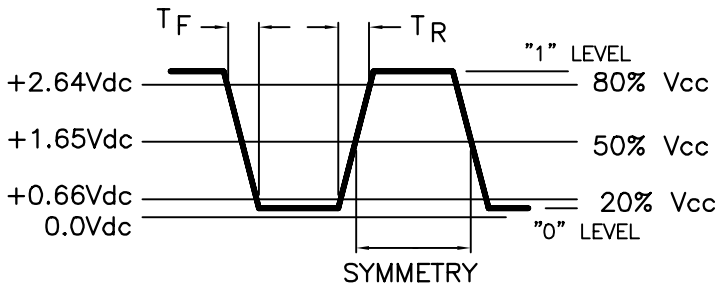

TEST CIRCUIT

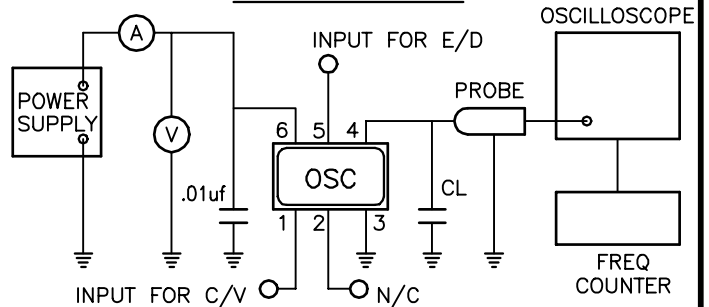

MECHANICAL CHARACTERISTICS

FREE DROP:

The specimen shall meet electrical characteristics after tested 3 times Free Drop testing on the hard wooden board from a height of 75cm.

VIBRATION:

The specimen shall meet electrical characteristics after tested by the following conditions;
10-55Hz 1.5mm Amplitude, 55-2000Hz 20G's, 2 hours for each phase.

THERMAL SHOCK:

After applied Thermal Shock of 245°C max x 10 sec max x 2 times, or 215°C max x 180 sec max, the specimen shall meet electrical characteristics.

SOLDERABILITY: (EIAJ-RCX-0102/101 Condition 1a)

1. Flux: MIL-F-14256 (WW Rosin=25%, Isopropyl alcohol=75%)
2. Solder: QQ-S-571 (Sn=63%, Pb=37%)
3. Solder bath temperature: 235°C ±5°C.
4. Depth of immersion: Up to electrical terminal.
5. Immersing time: Within 2 sec ±0.5 sec into solder bath.

After performing the above procedures, a newly soldered coverage shall be greater than 90%.

ENVIRONMENTAL CHARACTERISTICS

TEMPERATURE CYCLE:

The specimen shall meet electrical characteristics after tested 5 cycles of -55°C/30 min & +125°C/30 min.

HERMETICAL

No bubbles appear in Flourinert (FC-43) at 125°C ±5°C, for 5 minutes.

SOLVENT RESISTANCE:

Marking will withstand immersion in Isopropyl Alcohol or Trichloroethylene.

SOLDERING

GENERAL CONDITIONS:

245°C max x 10 sec max x 2 times max or 215°C max x 180 sec max x 1 time.

TYPICAL OPERATION DATA (Vapor phase reflow)

20 to 100 sec up to 215°C, 50 sec at 215°C then down to room temperature per 1 to 5°C/sec

TAPING AND REEL DIMENSIONS

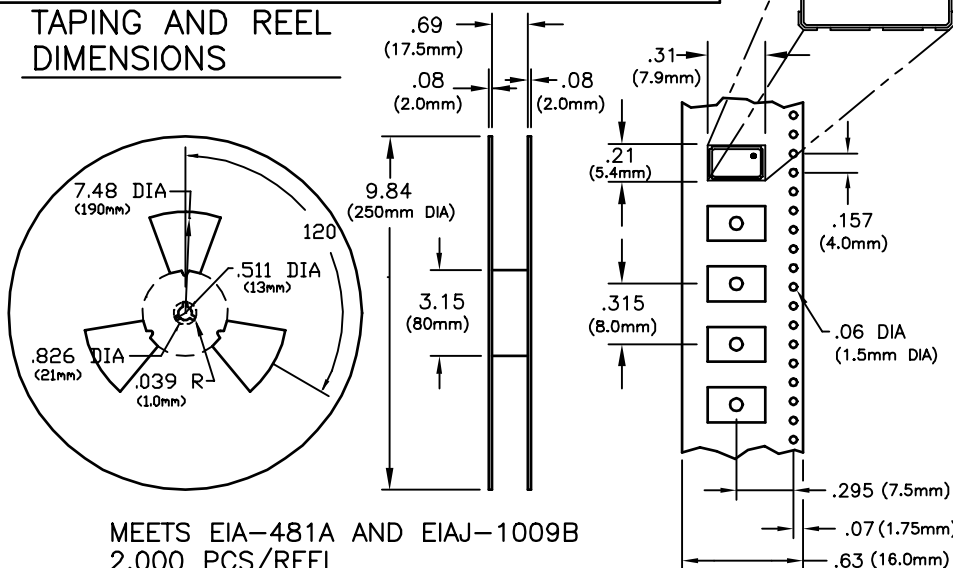

MEETS EIA-481A AND EIAJ-1009B
2,000 PCS/REEL

SUGGESTED PAD LAYOUT

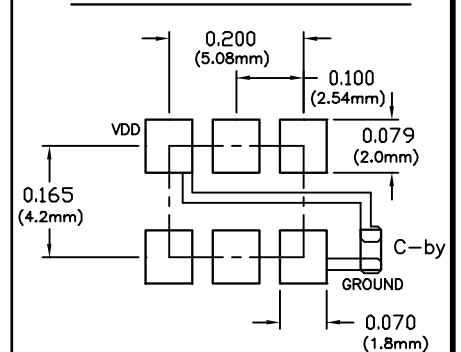

Bypass capacitor, C-by, should be ceramic capacitor ≥ .01uf.