

Serial port to Ethernet transceiver module

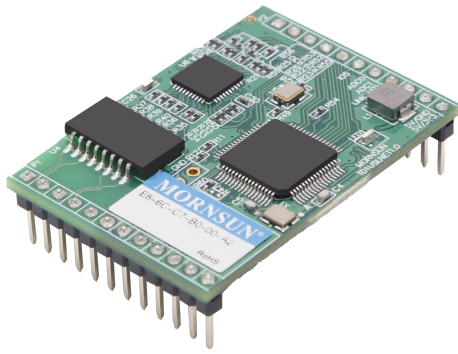

RoHS



TD1USLNET-4 is a module product that transmits serial port signals to Ethernet terminal. It can support TCP Client, TCP Server, UDP and REAL COM working modes. The module adopts the kernel of ARM Cortex-M4 RISC instruction set, and has strong information processing capacity. The data cache is up to 4KB. It can efficiently forward data between serial port and Ethernet, and the module can replace the development of Ethernet function of the customer system, so that the customer system has more advantages.

Product features

- Comply with IEEE802.3 standard
- Baud rate up to 921600bps
- 10/100M adaptive Ethernet interface
- Support TCP, UDP, REAL COM mode
- Support serial port, Telnet, configuration software, Web server configuration
- Internal integrated transformer, RJ45 communication is available
- Up to 1.5kVDC isolation between LAN side and serial port

Selection Guide

Certification	Product model	Power input (VDC)	Number of serial port channels	Number of Ethernet port channels	Working current(mA)	Operating temperature(°C)
-	TD1USLNET-4	3.15-3.45 4.5-30	1	1	3.3V:115(typ.) 5V:100(typ.)	-40 to 85

Absolute Limits

Item	Operating Conditions	Min.	Typ.	Max.	Unit
Input Surge Voltage(1sec. max.)	1sec. max.	-0.7	--	33	VDC
Pin Welding Resistance Temperature	Soldering time10s max.	--	--	300	°C

Input Specifications

Item	Symbol	Min.	Typ.	Max.	Unit
Input Voltage Of Power Supply (Type A)	TYPE A	3.15	3.3	3.45	VDC
Input Voltage Of Power Supply (Type B)	TYPE B	4.5	5	30	VDC
Input Current(3.3V)	$I_{in(3.3V)}$		115	140	mA
Input Current(5V)	$I_{in(5V)}$		100	115	mA
Input Current(15V)	$I_{in(15V)}$		35	50	mA
Input Current(30V)	$I_{in(30V)}$		18	25	mA
Serial Interface	3.3V standard TTL signal interface				
Network Interface	IEEE802.3 standard network interface				

Note: please refer to typical application circuits for the using of type A/B connection.

Serial Port Features

Item		Symbol	Min.	Typ.	Max.	Unit
TXD Logic Level	High-Level	V_{IH}	2	3.3	3.6	VDC
	Low-Level	V_{IL}		0	0.8	
RXD Logic Level	High-Level	V_{OH}	VCC-0.4	3.1	--	
	Low-Level	V_{OL}	--	0	0.4	
TXD Drive Current		I_t	2	--	--	mA

RXD Output Current	I _r	--	--	10	
Serial Port Baud Rate	Baud	1200	--	921600	bps
Maximum Subcontract Interval	SER _T	--	--	5	ms
Maximum Subcontract Length	SER _{LEN}	--	--	500	Byte

Network Features

Item	Symbol	Min.	Typ.	Max.	Unit
Network Speed	Adaptive network interface	10		100	Mbps
Maximum Number Of TCP Connections				4	
Working Mode Support	Support TCP Server, TCP Client, UDP, Real COM mode				

Other Features

Item	Symbol	Min.	Typ.	Max.	Unit
The Number Of IO				5	
The Number Of ADC				2	
The ADC Resolution				12	bit
ADC Maximum Error		-4		+4	LSB
485 Control interface	With 485 control interface, when the module sends data, 485EN is high level, and the rest are low level				

General Features

Item	Operating Conditions	Value
Isolation Voltage	Testing for 1 minute, leakage current <1mA,	1.5kVDC
Operating Temperature		-40℃ to +85℃
Transportation And Storage Temperature		-40℃ to +85℃
Operating Humidity	Non-condensing	10%-90%
Application Environment		The presence of dust, fierce vibration, impulsion and corrosive gas may cause damage to the product

Physical Specifications

Dimensions	44.45 x 31.30 mm
Weight	8.0g (Typ.)
Cooling Method	Free air convection

EMC Specifications

EMS	ESD	IEC/EN 61000-4-2	Contact ±2kV (Refer to figure 3, network ports)	Perf. Criteria B
	EFT	IEC/EN 61000-4-4	±1kV (Refer to figure 3, network ports)	Perf. Criteria B

Application Precautions

1. Please read the instructions carefully before using, call for our technical support if you have any questions;
2. Do not use the product in hazardous areas;
3. This product is powered by DC power supply, AC power supply is prohibited;
4. Do not dismount and assemble the product without permission to avoid failure or malfunction of equipment;
5. Hot-swap is not supported.

After-sales service

1. Ex-factory inspection and quality control have been strictly conducted for the product; if there occurs abnormal operation or possibility of failure of internal module, please contact the local representative or our technical support;
2. The warranty period for the product is 3 years as calculated from the date of delivery. If any quality problem occurs under normal use within the warranty period, the product can be repaired or changed for free.

Applied circuit

Refer to "Serial Port to Ethernet Module TD1USLNET-4 Application Guide".

Design Reference

1. Typical application circuit

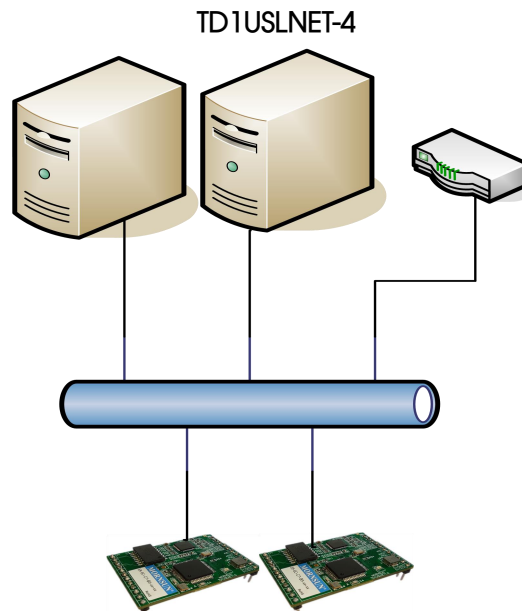

Figure 1

In general, the module is connected to the power supply, and the network port is connected with another network device or switch/ router. The recommended maximum communication distance is no more than 100m.

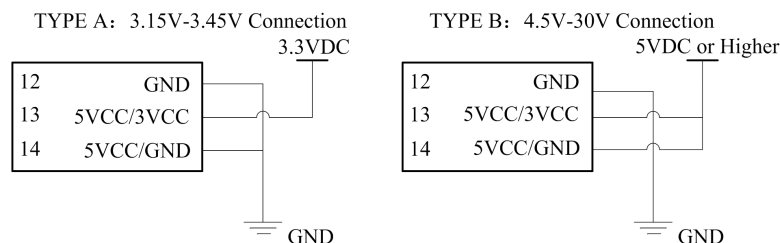

Figure 2

This module supports multiple power supply ranges. When supply voltage is 3.3V, using type A connection, pin 13 is connected to 3.3V, and pin 12 and 14 are connected to GND; when supply voltage is 5V(4.5~30V), using type B connection, pin 13 and 14 are connected to high voltage, Pin 12 is connected to GND.

During the application, none of the three power supply pins can be left floating, and the correct voltage must be connected, otherwise the product will not work.

2. Port protection recommended circuit

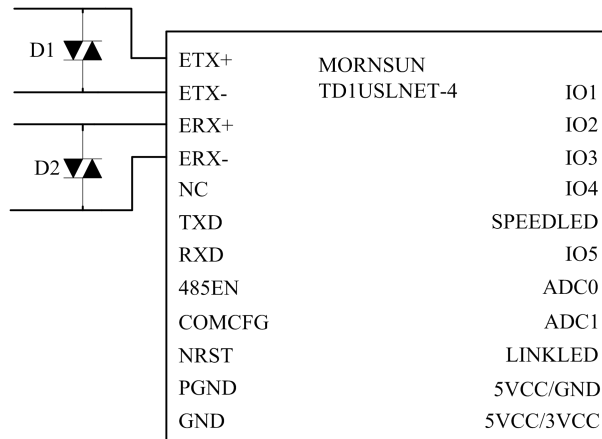

Figure 3

In the harsh environment of EMC, TVS tubes can be added for protection on ETX and ERX differential lines.

Parameter specification:

Components	Recommended parameter	Recommended brand
D1,D2	ESDBKU3V0D3	JIANGSU CHANGJING ELECTRONICS TECHNOLOGY CO., LTD (JSCJ)

3. For more information, please find the application note on www.mornsun-power.com

Dimensions and Recommended Layout

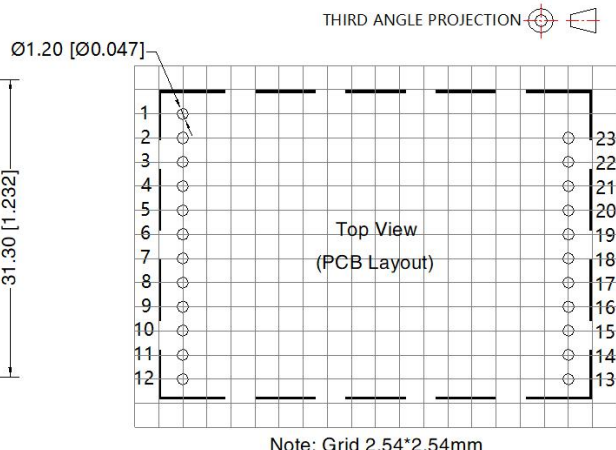
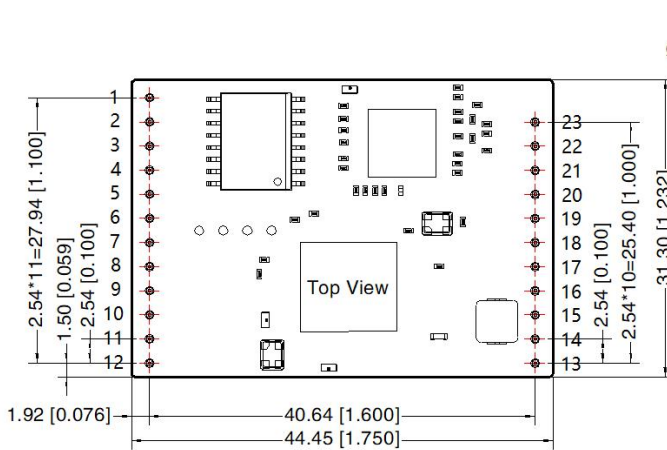

Note: Grid 2.54*2.54mm

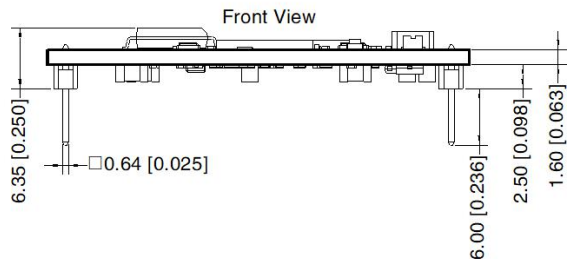

Note:
Unit: mm[inch]
Pin section tolerances: $\pm 0.10[\pm 0.004]$
General tolerances: $\pm 0.50[\pm 0.020]$
The layout of the device is for reference only, please refer to the actual product

Pin-Out			
Pin	Mark	Pin	Mark
1	ETX+	13	5VCC/3VCC
2	ETX-	14	5VCC/GND
3	ERX+	15	LINKLED
4	ERX-	16	ADC1
5	NC	17	ADC0
6	TXD	18	IO5
7	RXD	19	SPEEDLED
8	485EN	20	IO4
9	COMCFG	21	IO3
10	NRST	22	IO2
11	PGND	23	IO1
12	GND		

Notes:

- For additional information on Product Packaging please refer to www.mornsun-power.com. Packing bag number: 58240028;
- Unless otherwise specified, parameters in this datasheet were measured under the conditions of $T_a=25^{\circ}\text{C}$, humidity<75%RH with nominal input voltage and rated output load;
- All index testing methods in this datasheet are based on company corporate standards;
- The performance indexes of the product models listed in this datasheet are as above, but some indexes of non-standard model products will exceed the above-mentioned requirements, and please directly contact our technician for specific information;
- We can provide product customization service, please contact our technicians directly for specific information;
- Products are related to laws and regulations: see "Features" and "EMC";
- Our products shall be classified according to ISO14001 and related environmental laws and regulations, and shall be handled by qualified units.

Mornsun Guangzhou Science & Technology Co., Ltd.

Address: No. 5, Kehui St. 1, Kehui Development Center, Science Ave., Guangzhou Science City, Huangpu District, Guangzhou, P. R. China
Tel: 86-20-38601850 Fax: 86-20-38601272 E-mail: info@mornsun.cn www.mornsun-power.com