

National Semiconductor is now part of
Texas Instruments.

Search <http://www.ti.com/> for the latest technical
information and details on our current products and services.

REVISIONS			
LTR	DESCRIPTION	DATE (YR-MO-DA)	APPROVED
A	Changes in accordance with NOR 5962-R262-92. – sbr	92-07-16	M. A. Frye
B	Changes in accordance with NOR 5962-R065-93. – drw	93-01-11	M. A. Frye
C	Revise for 'D' certification. Editorial changes throughout. – drw	99-10-01	Raymond Monnin

THE ORIGINAL FIRST PAGE OF THIS DRAWING HAS BEEN REPLACED.

REV																				
SHEET																				
REV																				
SHEET																				
REV STATUS	REV	C	C	C	C	C	C	C	C	C	C	C								
OF SHEETS	SHEET	1	2	3	4	5	6	7	8	9	10									
PMIC N/A	PREPARED BY	Christopher A. Rauch																		
STANDARD MICROCIRCUIT DRAWING THIS DRAWING IS AVAILABLE FOR USE BY ALL DEPARTMENTS AND AGENCIES OF THE DEPARTMENT OF DEFENSE AMSC N/A	CHECKED BY	Ray Monnin																		
	APPROVED BY	Michael A. Frye																		
	DRAWING APPROVAL DATE	89-04-28																		
	REVISION LEVEL	C																		
	SIZE	CAGE CODE																		
	A	67268		5962-88631																
	SHEET	1 OF 10																		

1. SCOPE

1.1 Scope. This drawing describes device requirements for MIL-STD-883 compliant, non-JAN class level B microcircuits in accordance with MIL-PRF-38535, appendix A.

1.2 Part or Identifying Number (PIN). The complete PIN is as shown in the following example:

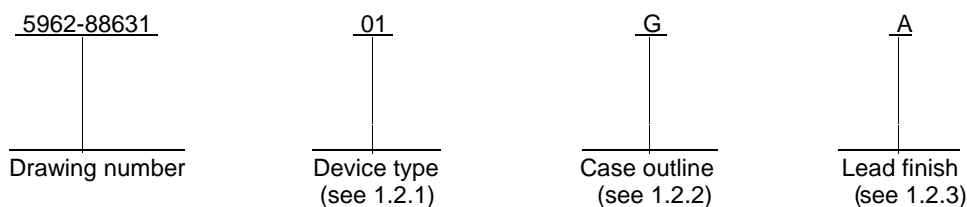

1.2.1 Device type(s). The device type(s) identify the circuit function as follows:

<u>Device type</u>	<u>Generic number</u>	<u>Circuit function</u>
01	DS1631	Dual AND peripheral driver, CMOS compatible, open collector

1.2.2 Case outline(s). The case outline(s) are as designated in MIL-STD-1835 and as follows:

<u>Outline letter</u>	<u>Descriptive designator</u>	<u>Terminals</u>	<u>Package style</u>
G	MACY1-X8	8	Can
P	GDIP1-T8 or CDIP2-T8	8	Dual-in-line

1.2.3 Lead finish. The lead finish is as specified in MIL-PRF-38535, appendix A.

1.3 Absolute maximum ratings.

Supply voltage (V_{CC})	16 V dc
Input voltage (V_{IN})	-0.3 V dc to $V_{CC} + 0.3$ V dc
Output voltage	56 V dc
Storage temperature range	-65°C to +150°C
Maximum power dissipation: <u>1/</u>	
Case G	787 mW
Case P	1133 mW
Lead temperature (soldering, 10 seconds)	+260°C
Thermal resistance, junction-to-case (θ_{JC})	See MIL-STD-1835
Junction temperature (T_J)	+175°C

1.4 Recommended operating conditions.

Case operating temperature range (T_C)	-55°C to +125°C
Operating supply voltage range (V_{CC})	4.5 V dc to 15 V dc

1/ For case P, derate 7.6 mW/°C above +25°C; for case G, derate 5.2 mW/°C above +25°C

STANDARD MICROCIRCUIT DRAWING DEFENSE SUPPLY CENTER COLUMBUS COLUMBUS, OHIO 43216-5000	SIZE A		5962-88631
		REVISION LEVEL C	SHEET 2

2. APPLICABLE DOCUMENTS

2.1 Government specification, standards, and handbooks. The following specification, standards, and handbooks form a part of this drawing to the extent specified herein. Unless otherwise specified, the issues of these documents are those listed in the issue of the Department of Defense Index of Specifications and Standards (DoDISS) and supplement thereto, cited in the solicitation.

SPECIFICATION

DEPARTMENT OF DEFENSE

MIL-PRF-38535 - Integrated Circuits, Manufacturing, General Specification for.

STANDARDS

DEPARTMENT OF DEFENSE

- MIL-STD-883 - Test Method Standard Microcircuits.
- MIL-STD-973 - Configuration Management.
- MIL-STD-1835 - Interface Standard For Microcircuit Case Outlines.

HANDBOOKS

DEPARTMENT OF DEFENSE

- MIL-HDBK-103 - List of Standard Microcircuit Drawings.
- MIL-HDBK-780 - Standard Microcircuit Drawings.

(Unless otherwise indicated, copies of the specification, standards, and handbooks are available from the Standardization Document Order Desk, 700 Robbins Avenue, Building 4D, Philadelphia, PA 19111-5094.)

2.2 Order of precedence. In the event of a conflict between the text of this drawing and the references cited herein, the text of this drawing takes precedence. Nothing in this document, however, supersedes applicable laws and regulations unless a specific exemption has been obtained.

3. REQUIREMENTS

3.1 Item requirements. The individual item requirements shall be in accordance with MIL-PRF-38535, appendix A for non-JAN class level B devices and as specified herein. Product built to this drawing that is produced by a Qualified Manufacturer Listing (QML) certified and qualified manufacturer or a manufacturer who has been granted transitional certification to MIL-PRF-38535 may be processed as QML product in accordance with the manufacturers approved program plan and qualifying activity approval in accordance with MIL-PRF-38535. This QML flow as documented in the Quality Management (QM) plan may make modifications to the requirements herein. These modifications shall not affect form, fit, or function of the device. These modifications shall not affect the PIN as described herein. A "Q" or "QML" certification mark in accordance with MIL-PRF-38535 is required to identify when the QML flow option is used. This drawing has been modified to allow the manufacturer to use the alternate die/fabrication requirements of paragraph A.3.2.2 of MIL-PRF-38535.

STANDARD MICROCIRCUIT DRAWING DEFENSE SUPPLY CENTER COLUMBUS COLUMBUS, OHIO 43216-5000	SIZE A		5962-88631
		REVISION LEVEL C	SHEET 3

3.2 Design, construction, and physical dimensions. The design, construction, and physical dimensions shall be as specified in MIL-PRF-38535, appendix A and herein.

3.2.1 Case outlines. The case outlines shall be in accordance with 1.2.2 herein.

3.2.2 Terminal connections. The terminal connections shall be as specified on figure 1.

3.2.3 Truth table. The truth table shall be as specified on figure 2.

3.2.4 Test circuits and switching waveforms. The test circuits and switching waveforms shall be as specified on figure 3.

3.3 Electrical performance characteristics. Unless otherwise specified herein, the electrical performance characteristics are as specified in table I and shall apply over the full case operating temperature range.

3.4 Electrical test requirements. The electrical test requirements shall be the subgroups specified in table II. The electrical tests for each subgroup are described in table I.

3.5 Marking. Marking shall be in accordance with MIL-PRF-38535, appendix A. The part shall be marked with the PIN listed in 1.2 herein. In addition, the manufacturer's PIN may also be marked as listed in MIL-HDBK-103 (see 6.6 herein). For packages where marking of the entire SMD PIN number is not feasible due to space limitations, the manufacturer has the option of not marking the "5962-" on the device.

3.5.1 Certification/compliance mark. The compliance mark for device class M shall be a "C" as required in MIL-PRF-38535, Appendix A. For product built in accordance with A.3.2.2 of MIL-PRF-38535, the "D" certification mark shall be used in place of the "C" certification mark.

3.6 Certificate of compliance. A certificate of compliance shall be required from a manufacturer in order to be listed as an approved source of supply in MIL-HDBK-103 (see 6.6 herein). The certificate of compliance submitted to DSCC-VA prior to listing as an approved source of supply shall affirm that the manufacturer's product meets the requirements of MIL-PRF-38535, appendix A and the requirements herein.

3.7 Certificate of conformance. A certificate of conformance as required in MIL-PRF-38535, appendix A shall be provided with each lot of microcircuits delivered to this drawing.

3.8 Notification of change. Notification of change to DSCC-VA shall be required in accordance with MIL-PRF-38535, appendix A.

3.9 Verification and review. DSCC, DSCC's agent, and the acquiring activity retain the option to review the manufacturer's facility and applicable required documentation. Offshore documentation shall be made available onshore at the option of the reviewer.

STANDARD MICROCIRCUIT DRAWING DEFENSE SUPPLY CENTER COLUMBUS COLUMBUS, OHIO 43216-5000	SIZE A		5962-88631
		REVISION LEVEL C	SHEET 4

TABLE I. Electrical performance characteristics. 1/

Test	Symbol	Conditions -55°C ≤ T _C ≤ +125°C unless otherwise specified	Group A subgroups	Device type	Limits		Unit
					Min	Max	
High level input voltage	V _{IH}	V _{CC} = 5 V, See figure 3	1, 2, 3	01	3.5		V
		V _{CC} = 10 V, See figure 3			8.0		
		V _{CC} = 15 V, See figure 3			12.5		
Low level input voltage	V _{IL}	V _{CC} = 5 V, See figure 3	1, 2, 3	01		1.5	V
		V _{CC} = 10 V, See figure 3				2.0	
		V _{CC} = 15 V, See figure 3				2.5	
High level output current	I _{OH}	V _{IN} = 15 V (all inputs), V _{CC} = 15 V, V _{OUT} = 54 V See figure 3	1, 2, 3	01		250	μA
Low level output voltage	V _{OL}	V _{IN} = 1.5 V, other inputs = 4.5 V V _{CC} = 4.5 V, I _{OL} = 100 mA See figure 3	1, 2, 3	01		1.1	V
		V _{IN} = 1.5 V, other inputs = 4.5 V V _{CC} = 4.5 V, I _{OL} = 300 mA See figure 3				1.4	
High level input current	I _{IH}	V _{IN} = 15 V, V _{CC} = 15 V, Other input of driver = 0.0 V See figure 3	1, 2, 3	01		10	μA
Low level input current	I _{IL}	V _{IN} = 0.4 V, V _{CC} = 15 V, Other input of driver = 15 V See figure 3	1, 2, 3	01		-360	μA
		V _{IN} = 0.4 V, V _{CC} = 5 V, Other input of driver = 5 V, See figure 3				-115.5	
High level breakdown voltage	V _{OH}	V _{CC} = 15 V, I _{OH} = 250 μA See figure 3	1, 2, 3	01	56		V
Functional tests		See 4.3.1c	7, 8	01			

See footnotes at end of table.

STANDARD MICROCIRCUIT DRAWING DEFENSE SUPPLY CENTER COLUMBUS COLUMBUS, OHIO 43216-5000	SIZE A		5962-88631
		REVISION LEVEL C	SHEET 5

TABLE I. Electrical performance characteristics – continued. 1/

Test	Symbol	Conditions -55°C ≤ T _C ≤ +125°C unless otherwise specified	Group A subgroups	Device type	Limits		Unit
					Min	Max	
Power supply current	I _{CCH}	V _{IN} = 5 V (all inputs), V _{CC} = 5 V, See figure 3	1, 2, 3	01		3	mA
		V _{IN} = 15 V (all inputs), V _{CC} = 15 V, See figure 3				10	
	I _{CCL}	V _{IN} = 0 V (all inputs), V _{CC} = 5 V, See figure 3				11	
		V _{IN} = 0 V (all inputs), V _{CC} = 15 V, See figure 3				20	
Propagation delay time	t _{PHL}	V _{CC} = 5 V, C _L = 15 pF, V _L = 10 V, R _L = 50Ω or equivalent, See figure 3 2/	9	01	.01	1.50	μS
			10, 11		.01	1.88	
	t _{PLH}		9		.01	1.20	
			10, 11		.01	1.50	

1/ Power dissipation must be externally controlled at elevated temperatures (+25°C and +125°C).

2/ The limits specified for subgroups 10 and 11 are guaranteed but not tested.

Case outlines	G and P
Terminal number	Pin
1	A1
2	B1
3	X1
4	GND
5	X2
6	A2
7	B2
8	V _{CC}

FIGURE 1. Terminal connections.

Inputs		Output
A	B	X
L	L	L
L	H	L
H	L	L
H	H	H

FIGURE 2. Truth table.

STANDARD MICROCIRCUIT DRAWING DEFENSE SUPPLY CENTER COLUMBUS COLUMBUS, OHIO 43216-5000	SIZE A		5962-88631
		REVISION LEVEL C	SHEET 6

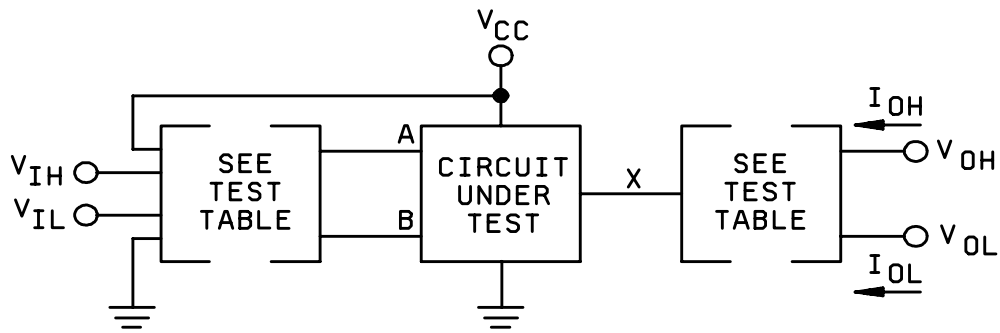

Test table

Input under test	Other input	Output	
		Apply	Measure
V_{IH}	V_{IH}	I_{OH}	V_{OH}
V_{IL}	V_{CC}	I_{OL}	V_{OL}

V_{IH} , V_{IL} , test.

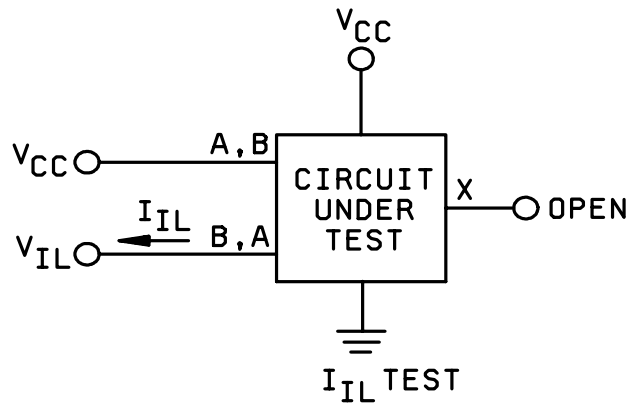

FIGURE 3. Test circuits and switching waveforms.

**STANDARD
MICROCIRCUIT DRAWING**
DEFENSE SUPPLY CENTER COLUMBUS
COLUMBUS, OHIO 43216-5000

SIZE
A

5962-88631

REVISION LEVEL
C

SHEET
7

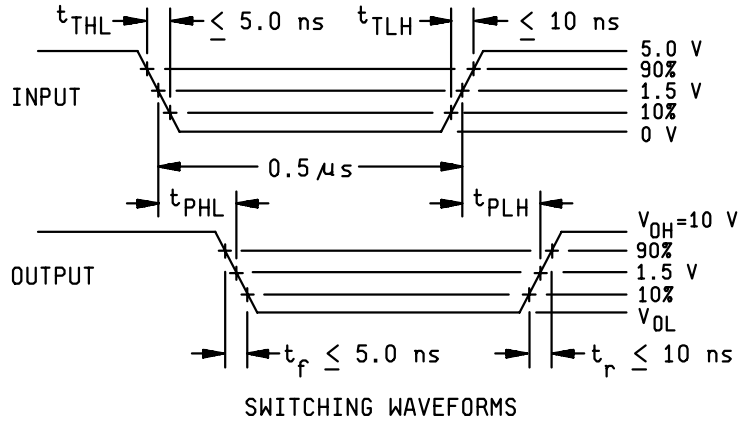
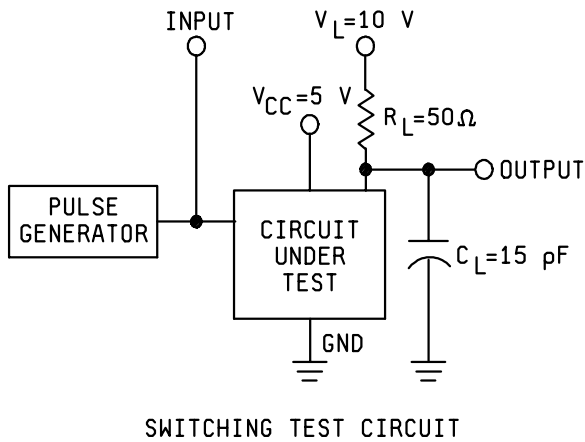
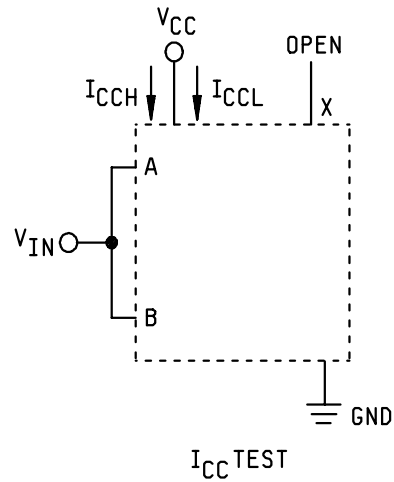
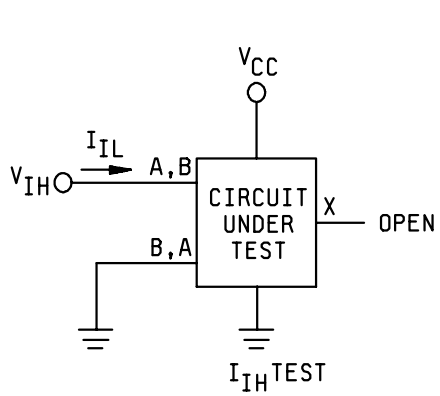

NOTES:

1. The pulse generator has the following characteristics:
PRR = 500 kHz, $Z_{OUT} = 50\Omega$
2. C_L includes probe and jig capacitance.
3. I_{IH} and I_{IL} test, each input is tested separately.
4. I_{CC} test, both gates are tested simultaneously.

FIGURE 3. Test circuits and switching waveforms - continued.

STANDARD MICROCIRCUIT DRAWING DEFENSE SUPPLY CENTER COLUMBUS COLUMBUS, OHIO 43216-5000	SIZE A		5962-88631
		REVISION LEVEL C	SHEET 8

4. QUALITY ASSURANCE PROVISIONS

4.1 Sampling and inspection. Sampling and inspection procedures shall be in accordance with MIL-PRF-38535, appendix A.

4.2 Screening. Screening shall be in accordance with method 5004 of MIL-STD-883, and shall be conducted on all devices prior to quality conformance inspection. The following additional criteria shall apply:

- a. Burn-in test, method 1015 of MIL-STD-883.
 - (1) Test condition A, B, C or D. The test circuit shall be maintained by the manufacturer under document revision level control and shall be made available to the preparing or acquiring activity upon request. The test circuit shall specify the inputs, outputs, biases, and power dissipation, as applicable, in accordance with the intent specified in test method 1015 of MIL-STD-883.
 - (2) $T_A = +125^\circ\text{C}$, minimum.
- b. Interim and final electrical test parameters shall be as specified in table II herein, except interim electrical parameter tests prior to burn-in are optional at the discretion of the manufacturer.

TABLE II. Electrical test requirements.

MIL-STD-883 test requirements	Subgroups (in accordance with MIL-STD-883, method 5005, table I)
Interim electrical parameters (method 5004)	1
Final electrical test parameters (method 5004)	1*, 2, 3, 9
Group A test requirements (method 5005)	1, 2, 3, 7, 8, 9, 10, 11
Groups C and D end-point electrical parameters (method 5005)	1, 2, 3

* PDA applies to subgroup 1.

4.3 Quality conformance inspection. Quality conformance inspection shall be in accordance with method 5005 of MIL-STD-883 including groups A, B, C, and D inspections. The following additional criteria shall apply.

4.3.1 Group A inspection.

- a. Tests shall be as specified in table II herein.
- b. Subgroups 4, 5, and 6 in table I, method 5005 of MIL-STD-883 shall be omitted.
- c. Subgroups 7 and 8 shall include verification of the truth table.

STANDARD MICROCIRCUIT DRAWING DEFENSE SUPPLY CENTER COLUMBUS COLUMBUS, OHIO 43216-5000	SIZE A		5962-88631
		REVISION LEVEL C	SHEET 9

4.3.2 Groups C and D inspections.

- a. End-point electrical parameters shall be as specified in table II herein.
- b. Steady-state life test conditions, method 1005 of MIL-STD-883.
 - (1) Test condition A, B, C, or D. The test circuit shall be maintained by the manufacturer under document revision level control and shall be made available to the preparing or acquiring activity upon request. The test circuit shall specify the inputs, outputs, biases, and power dissipation, as applicable, in accordance with the intent specified in test method 1005 of MIL-STD-883.
 - (2) $T_A = +125^\circ\text{C}$, minimum.
 - (3) Test duration: 1,000 hours, except as permitted by method 1005 of MIL-STD-883.

5. PACKAGING

5.1 Packaging requirements. The requirements for packaging shall be in accordance with MIL-PRF-38535, appendix A.

6. NOTES

6.1 Intended use. Microcircuits conforming to this drawing are intended for use for Government microcircuit applications (original equipment), design applications, and logistics purposes.

6.2 Replaceability. Microcircuits covered by this drawing will replace the same generic device covered by a contractor-prepared specification or drawing.

6.3 Configuration control of SMD's. All proposed changes to existing SMD's will be coordinated with the users of record for the individual documents. This coordination will be accomplished in accordance with MIL-STD-973 using DD Form 1692, Engineering Change Proposal.

6.4 Record of users. Military and industrial users shall inform Defense Supply Center Columbus when a system application requires configuration control and the applicable SMD. DSCC will maintain a record of users and this list will be used for coordination and distribution of changes to the drawings. Users of drawings covering microelectronics devices (FSC 5962) should contact DSCC-VA, telephone (614) 692-0525.

6.5 Comments. Comments on this drawing should be directed to DSCC-VA, Columbus, Ohio 43216-5000, or telephone (614) 692-0674.

6.6 Approved sources of supply. Approved sources of supply are listed in MIL-HDBK-103. The vendors listed in MIL-HDBK-103 have agreed to this drawing and a certificate of compliance (see 3.6 herein) has been submitted to and accepted by DSCC-VA.

STANDARD MICROCIRCUIT DRAWING DEFENSE SUPPLY CENTER COLUMBUS COLUMBUS, OHIO 43216-5000	SIZE A		5962-88631
		REVISION LEVEL C	SHEET 10

STANDARD MICROCIRCUIT DRAWING BULLETIN

DATE: 99-10-01

Approved sources of supply for SMD 5962-88631 are listed below for immediate acquisition information only and shall be added to MIL-HDBK-103 during the next revision. MIL-HDBK-103 will be revised to include the addition or deletion of sources. The vendors listed below have agreed to this drawing and a certificate of compliance has been submitted to and accepted by DSCC-VA. This bulletin is superseded by the next dated revision of MIL-HDBK-103.

Standard microcircuit drawing PIN <u>1/</u>	Vendor CAGE number	Vendor similar PIN <u>2/</u>
5962-8863101GA	<u>3/</u>	DS1631H/883
5962-8863101PA	0EU86	AS1631C8/883C

- 1/ The lead finish shown for each PIN representing a hermetic package is the most readily available from the manufacturer listed for that part. If the desired lead finish is not listed contact the vendor to determine its availability.
- 2/ Caution. Do not use this number for item acquisition. Items acquired to this number may not satisfy the performance requirements of this drawing.
- 3/ Not available from an approved source.

Vendor CAGE
number

0EU86

Vendor name
and address

Austin Semiconductor Inc.
8701 Cross Park Dr.
Austin, TX 78754-4566

The information contained herein is disseminated for convenience only and the Government assumes no liability whatsoever for any inaccuracies in the information bulletin.