

OKI Semiconductor

MSM6652/53/54/55/56-XXX, MSM6652A/53A/54A/55A/56A/ 58A-XXX, MSM66P54-XX, MSM6650

Internal Mask ROM Voice Synthesis IC, Internal 1-Mbit One-Time-Programmable (OTP) ROM Voice Synthesis IC, External ROM Drive Voice Synthesis IC

GENERAL DESCRIPTION

The MSM6650 family is the successor to OKI's MSM6375 family. To ensure high-quality voice synthesis, the MSM6650 family members offer adaptive differential pulse-code modulation (ADPCM) playback, pulse-code modulation (PCM) playback, 12-bit D/A conversion, and on-chip -40 dB/octave low-pass filter (LPF).

The conventional "beep" tones and 2-channel playback are now easier to use. OKI has added additional functions such as melody play, fade-out, and random playback. OKI has improved external control by adding an Edit ROM. The Edit ROM can be used to form sentences by linking phrases.

The MSM6650 family members can support a variety of applications as it can function in either Standalone Mode or Microcontroller Interface Mode. In Microcontroller Interface Mode, serial input control is available. Serial input control minimizes the number of microcontroller port pins required for voice synthesis control. The MSM6650 family includes an internal mask ROM version, internal one-time-programmable (OTP) ROM version, and external ROM version. The features of the MSM6650 family devices are as follows.

- **MSM6652/53/54/55/56-XXX**
These devices are single-chip voice synthesizers with an on-chip mask ROM using the CMOS technology.
Standalone Mode or Microcontroller Interface Mode can be selected by mask option.
- **MSM6652A/53A/54A/55A/56A/58A-XXX**
The prototyping time for these devices is shorter than those described above. These devices are suitable for prototyping and concept demonstration of new products.
- **MSM66P54-XX**
The device is a single-chip CMOS voice synthesizer with one-time-programmable (OTP) ROM. Standalone and Microcontroller Interface Modes are selected by using a code (01-04).
The user can easily write voice data using the development tool AR761 or AR762, or P54 adapter. Unlike the mask ROM version, the OTP version is suited to applications which requires a small lot production of different type devices or short delivery time.
- **MSM6650**
The MSM6650 device can directly connect external ROM or EPROM of up to 64 Mbits, which stores voice data.
This device is ideally suited to an evaluation IC for the MSM6650 family because its circuit configuration is identical to those of the mask ROM-based and OTP version devices.

Note: This data sheet explains a stand-alone mode and a microcontroller interface mode, separately.

CONTENTS

Standalone Mode

FEATURES	76
BLOCK DIAGRAMS	78
PIN CONFIGURATION	81
PIN DESCRIPTIONS	83
ABSOLUTE MAXIMUM RATINGS	85
RECOMMENDED OPERATING CONDITIONS	85
ELECTRICAL CHARACTERISTICS	86
TIMING DIAGRAMS	88
FUNCTIONAL DESCRIPTION	90
1. PLAYBACK CODE SPECIFICATION	90
2. INTERNAL ROM USAGE AND DISABLED AREA	90
3. PULL-UP/PULL-DOWN RESISTOR	90
4. OPTION(S)	91
5. STANDALONE MODE	91
6. SAMPLING FREQUENCY	98
7. VOICE PLAYBACK TIME	98
8. CHANNEL STATUS	99
9. PLAYBACK METHOD	99
10. STANDBY CONVERSION	102
11. VOICE OUTPUT	102
12. LOW-PASS FILTER POP NOISE	104
13. RC OSCILLATION	105
14. CERAMIC OSCILLATION	109
15. POWER SUPPLY	110
APPLICATION CIRCUITS	111

Microcontroller Interface Mode

FEATURES	115
BLOCK DIAGRAMS	117
PIN CONFIGURATION	120
PIN DESCRIPTIONS	122
ABSOLUTE MAXIMUM RATINGS	124
RECOMMENDED OPERATING CONDITIONS	124
ELECTRICAL CHARACTERISTICS	125
TIMING DIAGRAMS	127
FUNCTIONAL DESCRIPTION	133
1. PLAYBACK CODE SPECIFICATION	133
2. INTERNAL ROM USAGE AND DISABLED AREA	133
3. PULL-UP/PULL-DOWN RESISTOR	134
4. OPTIONS	134
5. MICROCONTROLLER INTERFACE MODE	137
6. COMMAND DATA	141
7. ADDRESS DATA	148
8. STOP CODE	149
9. SAMPLING FREQUENCY	151
10. VOICE PLAYBACK TIME	151
11. CHANNEL STATUS	152
12. PLAYBACK METHOD	152
13. STANDBY CONVERSION	155
14. VOICE OUTPUT	155
15. LOW-PASS FILTER POP NOISE	157
16. CERAMIC OSCILLATION	158
17. POWER SUPPLY	159
18. EXTERNAL ROM DRIVING TIMING	160
APPLICATION CIRCUITS	162

Common

EDIT ROM	166
ECHO PLAYBACK OF A SINGLE PHRASE	175
ECHO PLAYBACK OF MULTIPLE PHRASES	178
ECHO PLAYBACK OF A SINGLE PHRASE WITHIN A PHRASE STRING	179

The table below shows the major differences between the MSM6650 family and the MSM6375 family.

	MSM6650 Family	MSM6375 Family																										
Interface	Standalone mode/Microcontroller interface mode	SW input/CPU input interface																										
Voice synthesis method	4-bit ADPCM or 8-bit PCM/Melody PCM	4-bit ADPCM																										
"Beep" tone frequency (length)	0.5, 1.0, 1.3, 2.0 kHz Options (16 ms to 2100 ms)	1.0 or 2.0 kHz, (User-specified length, fixed at either 64, 128, 250, or 500 ms)																										
Sampling frequency (f_s)	Eight frequencies (4.0, 5.3, 6.4, 8.0, 10.6, 12.8, 16.0, or 32.0 kHz)	Three frequencies at two oscillator frequencies (4.0, 6.4, 8.0 kHz with $f_{osc}=64$ kHz; 16.0, 25.6, 32.0 kHz with $f_{osc}=256$ kHz)																										
Master clock frequency (f_{osc})	256 kHz (RC)/4.096 MHz (ceramic/crystal)	40 kHz to 256 kHz																										
LPF attenuation factor	-40 dB/octave	-24 dB/octave																										
LPF cut-off frequency (f_{cut}), kHz	<table border="1"> <tr> <td>f_{cut}</td> <td>1.8</td> <td>2.6</td> <td>2.6</td> <td>3.2</td> <td>4.2</td> <td>5.1</td> <td>6.4</td> <td>12.8</td> </tr> <tr> <td>f_s</td> <td>4.0</td> <td>5.3</td> <td>6.4</td> <td>8.0</td> <td>10.6</td> <td>12.8</td> <td>16.0</td> <td>32.0</td> </tr> </table>	f_{cut}	1.8	2.6	2.6	3.2	4.2	5.1	6.4	12.8	f_s	4.0	5.3	6.4	8.0	10.6	12.8	16.0	32.0	<table border="1"> <tr> <td>f_{cut}</td> <td>1.5</td> <td>3.0</td> <td>3.0</td> </tr> <tr> <td>f_s</td> <td>4.0</td> <td>6.4</td> <td>8.0</td> </tr> </table>	f_{cut}	1.5	3.0	3.0	f_s	4.0	6.4	8.0
f_{cut}	1.8	2.6	2.6	3.2	4.2	5.1	6.4	12.8																				
f_s	4.0	5.3	6.4	8.0	10.6	12.8	16.0	32.0																				
f_{cut}	1.5	3.0	3.0																									
f_s	4.0	6.4	8.0																									
Maximum phrase number	127	111																										
Pull-up/pull-down resistors	Built in	—																										
Standby conversion time	0.2 sec	3 sec																										
Mask options	4 options	14 options																										
Added function in edit ROM	Edit ROM Fade-out Random playback Melody playback PCM playback Serial input/port output	—																										

STANDALONE MODE

FEATURES

Device name	ROM size	Maximum playback time (sec)			
		$f_S=4.0$ kHz	$f_S=6.4$ kHz	$f_S=8.0$ kHz	$f_{SAM}=16$ kHz
MSM6652, 6652A	288 Kbits	16.9	10.5	8.4	4.2
MSM6653, 6653A	544 Kbits	31.2	19.5	15.6	7.8
MSM6654, 6654A	1 Mbit	63.8	39.9	31.9	15.9
MSM6655, 6655A	1.5 Mbits	96.5	60.3	48.2	24.1
MSM6656, 6656A	2 Mbits	129.1	80.7	64.5	32.2
MSM6658A	4 Mbits	259.7	162.9	129.8	64.9
MSM66P54	1 Mbit	63.8	39.9	31.9	15.9
MSM6650	64 Mbits (Max)	4194.3	2620.5	2096.4	1048.2

Note: Actual voice ROM area is smaller by 22 Kbits.

- 4-bit ADPCM or 8-bit PCM sound generation
- Melody function
- Edit ROM function
- Two-channel mixing function
- Built-in random playback function
- Fade-out function via four-step sound volume attenuation
- Built-in beep tone of 0.5 kHz, 1.0 kHz, 1.3 kHz, or 2.0 kHz selectable with a specific code
- Sampling frequency of 4.0 kHz, 5.3 kHz, 6.4 kHz, 8.0 kHz, 10.6 kHz, 12.8 kHz, 16.0 kHz, or 32.0 kHz (32 kHz sampling is not possible when using RC oscillation)
- Up to 120 phrases
- Built-in 12-bit D/A converter
- Built-in -40 dB/octave low-pass filter
- Standby function
- Selectable RC or ceramic oscillation
- Package options:
 - MSM6652/53/54/55/56: 18-pin plastic DIP (DIP18-P-300)
(not applied to MSM6658A)
 - MSM6652A/53A/54A/55A/56A/58A: 24-pin plastic SOP (SOP24-P-430-VK)
 - MSM66P54: 20-pin plastic DIP (DIP20-P-300-W1)
24-pin plastic SOP (SOP24-P-430-VK)
 - MSM6650: 64-pin plastic QFP (QFP64-P-1420-BK)
64-pin plastic SDIP (SDIP64-P-750)

• Option Table

	Pin Name	Microcontroller Interface Mode		Standalone Mode		
		Serial Input	Parallel Input	With Standby	No Standby	
MSM6652/53/54/55/56 MSM6652A/53A/54A/55A/56A/58A	—	Mask Option (Note1)				
MSM66P54	—	-01	-02	-03	-04	(Note2)
MSM6650	CPU	"H"	"H"	"L"	"L"	
	SERIAL	"H"	"L"	"L"	"L"	
	STBY	"H"	"H"	"L"	"H"	

- Note: 1. Mask ROM-based devices are mask optioned. The user should send OKI an option list before starting development.
A sample of option list is shown below.
2. A code of OTP version device corresponds to one of the options. The user should specify either MSM66P54-03 or MSM66P54-04. (In this case, no option list is required.)

Oki Electric Industry Co., Ltd. Date: _____

Option List

You are requested to develop MSM665X-XXX on the following conditions.

1. Options
There are four options for the MSM6650 family.
Choose and circle the desired option.

Option	Interface mode	Input	Standby conversion
Option A	Microcontroller	Serial	—
Option B	Microcontroller	Parallel	—
Option C	Standalone	—	Yes
Option D	Standalone	—	No

2. Package and quantity

Item	Package (circle the desired one)			Quantity	Note
Ceramic sample	18-pin DIP (ceramic)	24-pin SOP (ceramic)	chip	___ pcs	Up to 10 samples. Operating temp. : 10 to 30°C
Mold sample	18-pin DIP (plastic)	24-pin SOP (plastic)	chip	___ pcs	Up to 50 samples
Mass production	18-pin DIP (plastic)	24-pin SOP (plastic)	chip	___ pcs per lot monthly	

Signed by _____
Title : _____
Company name : _____

BLOCK DIAGRAMS

MSM6652/53/54/55/56-XXX

MSM6652A/53A/54A/55A/56A/58A-XXX

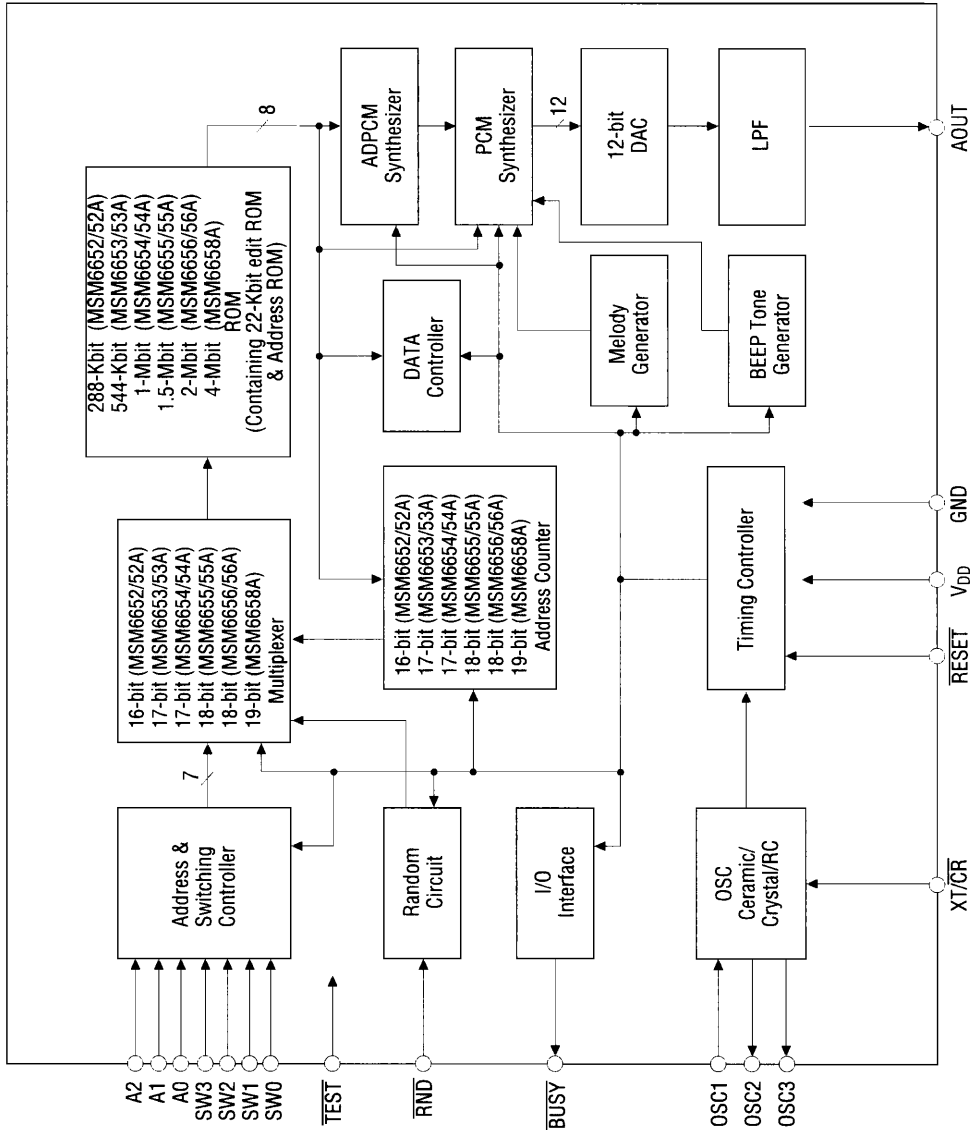

MSM66P54-XX

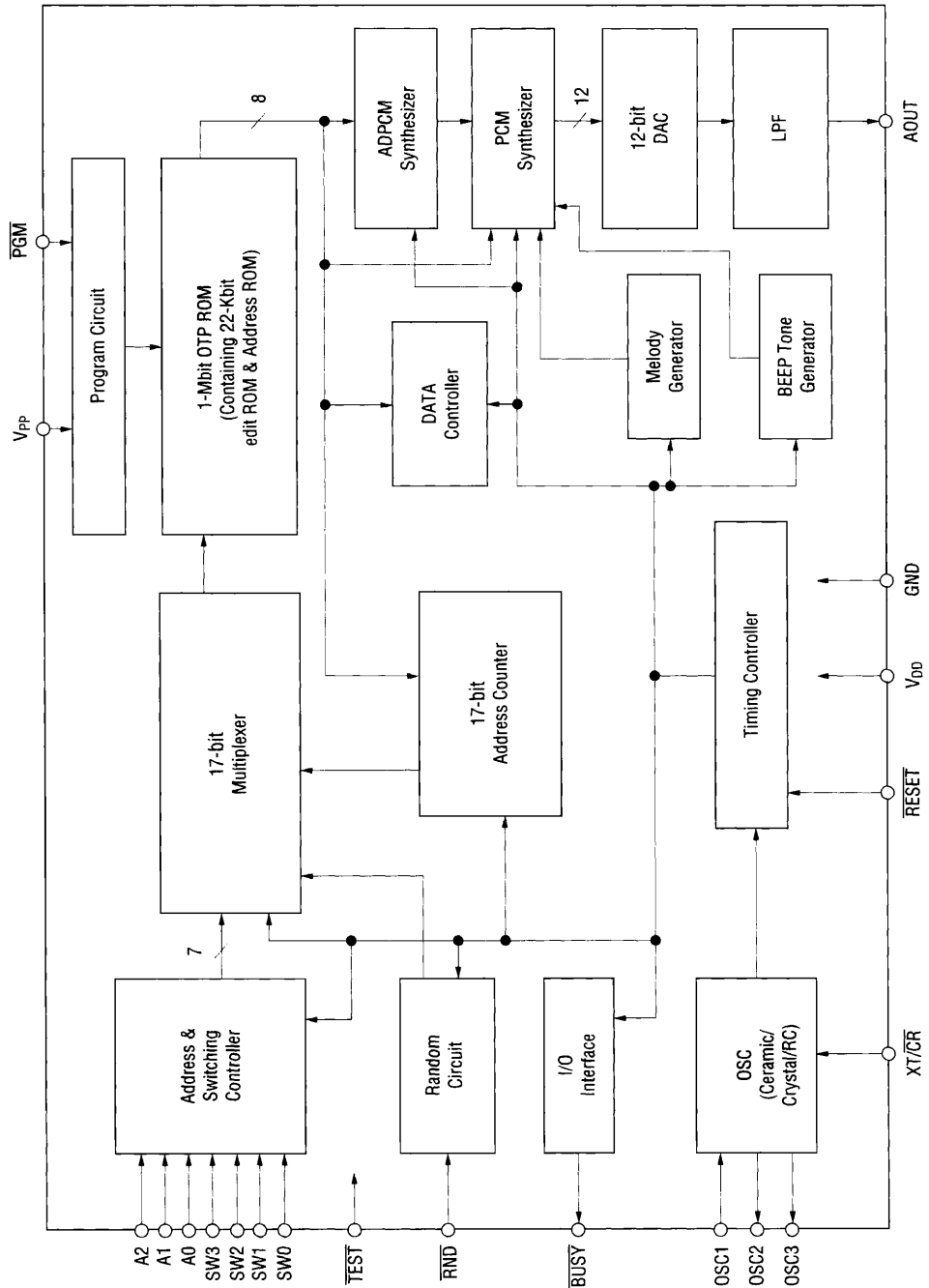

MSM6650

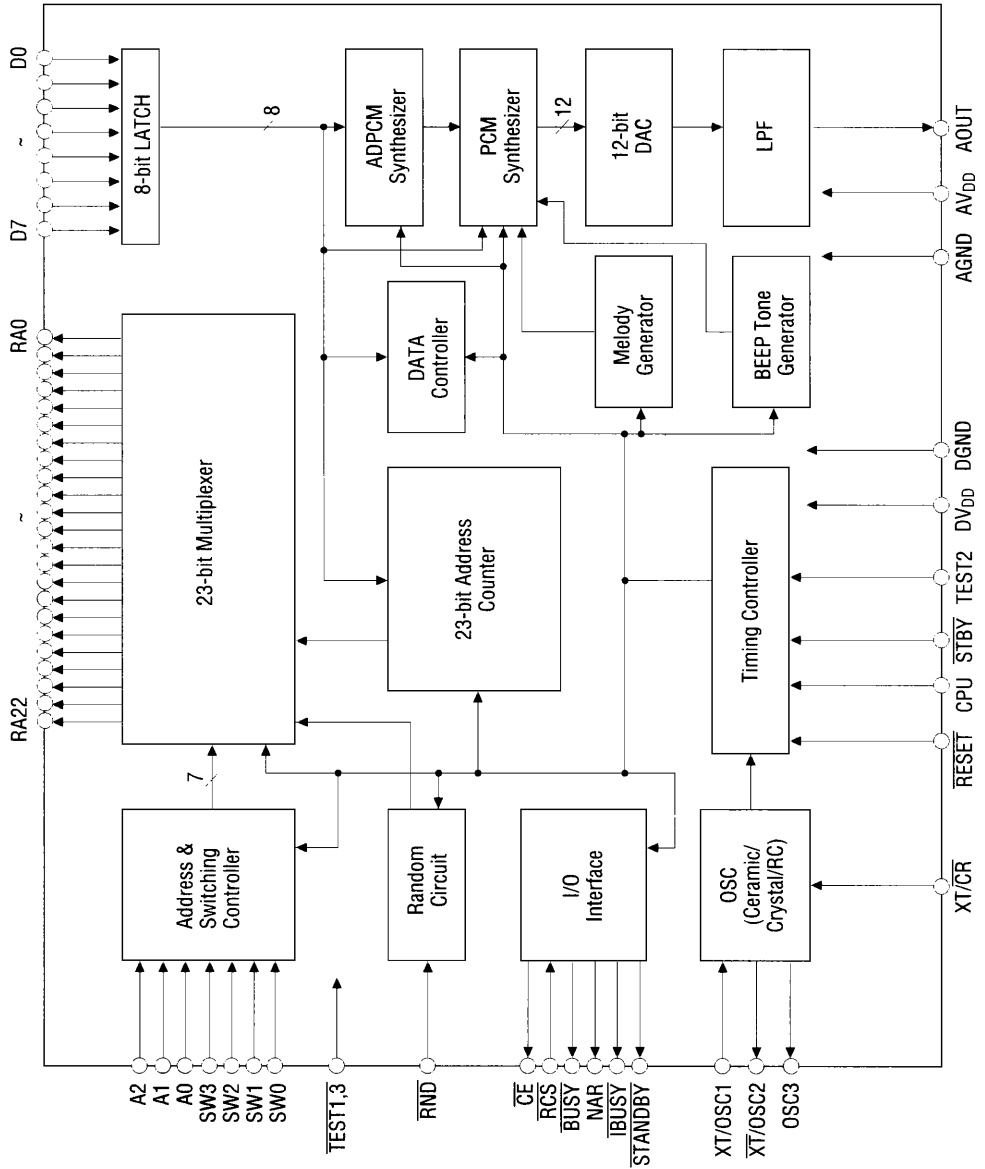

PIN CONFIGURATION (TOP VIEW)

The MSM66P54-XX has two more pins than the MSM6652-6656 while their pin configurations are identical.

The additional two pins (V_{PP} , \overline{PGM}) of the MSM66P54-XX may be open at playback after completion of writing.

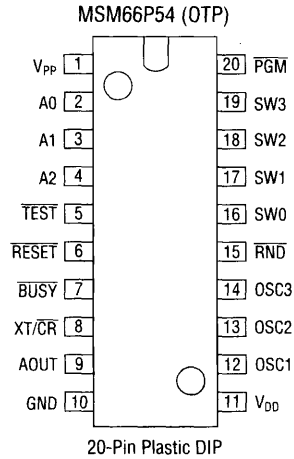
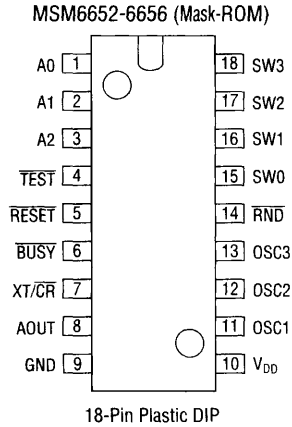

MSM66P54-03/-04RS

MSM6652-XXXRS, MSM6653-XXXRS, MSM6654-XXXRS,
MSM6655-XXXRS, MSM6656-XXXRS, MSM6652A-XXXRS,
MSM6653A-XXXRS, MSM6654A-XXXRS,
MSM6655A-XXXRS, MSM6656A-XXXRS

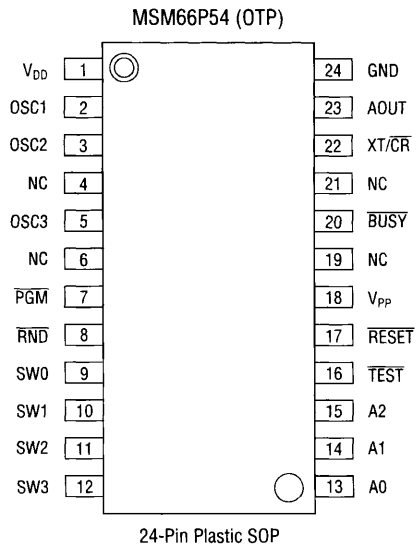
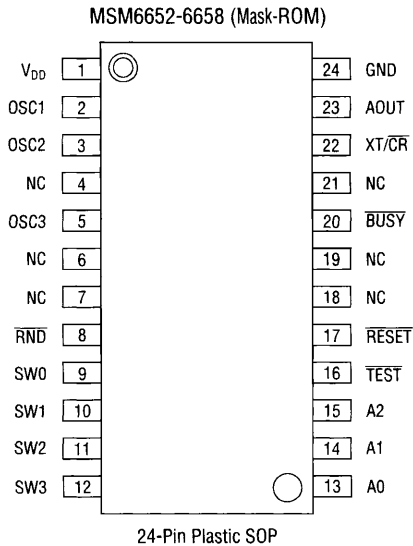

MSM66P54-03/-04GS-VK

MSM6652-XXXGS-VK, MSM6653-XXXGS-VK
MSM6654-XXXGS-VK, MSM6655-XXXGS-VK,
MSM6656-XXXGS-VK, MSM6652A-XXXGS-VK,
MSM6653A-XXXGS-VK, MSM6654A-XXXGS-VK,
MSM6655A-XXXGS-VK, MSM6656A-XXXGS-VK,
MSM6658A-XXXGS-VK

MSM6650

Product name: MSM6650GS-BK

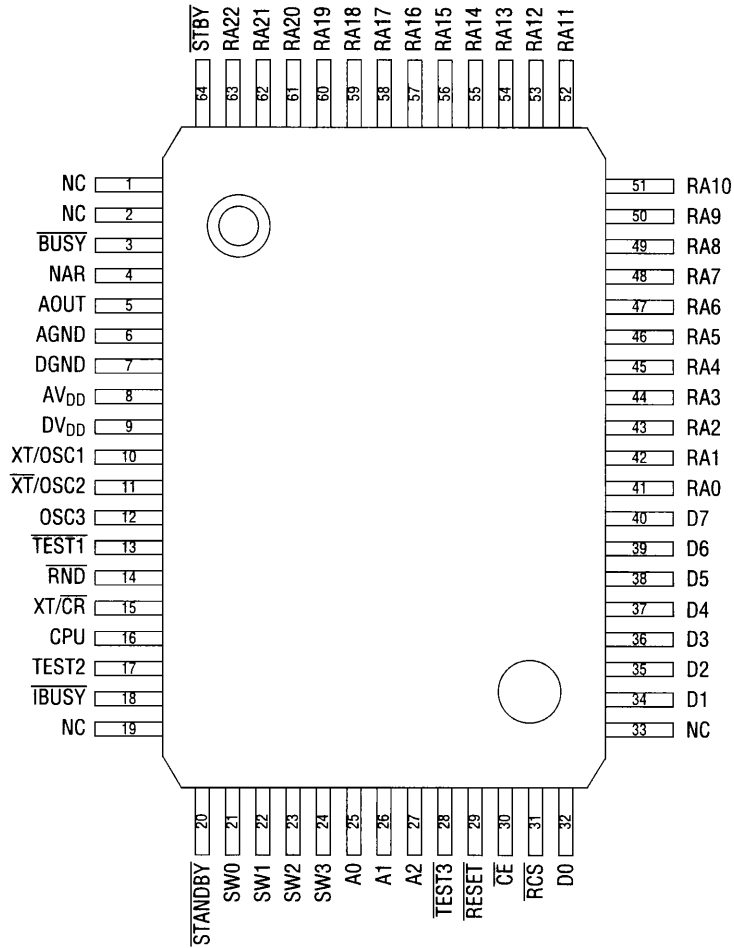

64-Pin Plastic QFP

PIN DESCRIPTIONS

Common pins for MSM6652/53/54/55/56-XXX, MSM6652A/53A/54A/55A/56A/58A-XXX, MSM66P54-XX, MSM6650

Symbol	Type	Description
$\overline{\text{RESET}}$	I	Reset. Setting this pin to "L" puts the device in standby status. At this time, oscillation stops, AOUT is pulled to GND, and the device is initialized. The MSM6650 family devices have an internal power-on reset. To operate the power-on reset correctly, power should ramp up within 1 ms. If this is not possible, apply a $\overline{\text{RESET}}$ pulse when power is turned on. This pin has an internal pull-up resistor.
BUSY	O	Busy. This pin outputs a "L" level during playback. At power-on, this pin is at "H" level.
XT/ $\overline{\text{CR}}$	I	XT/$\overline{\text{CR}}$ selectable pin. Set to "H" level when using ceramic oscillation. Set to "L" level when using RC oscillation.
AOUT	O	Sound Output. This is the synthesized output pin of the internal low-pass filter.
GND	—	Ground.
V _{DD}	—	Power supply.
OSC1	I	Oscillator 1. This pin is a ceramic oscillator connection pin when using ceramic oscillation. This pin is an RC connection pin when using RC oscillation. When using an external clock, use this pin as the clock input.
OSC2	O	Oscillator 2. This pin is a ceramic oscillator connection pin when using a ceramic oscillator. This is an RC connection pin when using RC oscillation. Leave open if using an external clock. OSC2 outputs a "L" level in standby status.
OSC3	O	Oscillator 3. Leave open if using a ceramic oscillator. This pin is the RC connection pin when using RC oscillation. When RC oscillation is selected, OSC3 outputs a "H" level in standby status.
$\overline{\text{RND}}$	I	Random Playback. Random playback starts when the $\overline{\text{RND}}$ pin is set to a "L" level. At the fall of $\overline{\text{RND}}$, addresses from the random address playback circuit inside the IC are fetched. Set to a "H" level if random playback is not used. This pin has an internal pull-up resistor.
SW0-SW3	I	Phrase Inputs. These pins are phrase input pins corresponding to playback. If the input changes, SW0 to SW3 pins capture address data after 16 ms and speech playback commences. These pins have internal pull-down resistors.
A0-A2	I	Phrase Inputs. Phrase input pins corresponding to playback. The A0 input becomes invalid when the random playback function is used.

Common pins for MSM6652/53/54/55/56-XXX, MSM6652A/53A/54A/55A/56A/58A-XXX, MSM66P54-XX

Symbol	Type	Description
GND	—	Ground.
V _{DD}	—	Power supply.
TEST	I	Test Mode. Set to "H" level. This pin has an internal pull-up resistor.

Pins for MSM66P54-XX

Symbol	Type	Description
V_{pp}	—	Power supply used when writing data to internal OTP ROM. Leave open or set to "H" level during playback.
\overline{PGM}	I	Interface with voice analysis edit tool AR761 or AR762. Set to "L" level or leave open during playback.

Pins for MSM6650

Symbol	Type	Description
\overline{CE}	—	Chip Enable. \overline{CE} is a timing output pin to control read of external memory. This pin outputs when \overline{RCS} is at the "L" level. This pin goes high impedance when \overline{RCS} is at the "H" level.
CPU	I	CPU Mode. Set to "L" level to select Standalone Mode. Set to "H" level to select Microcontroller Interface Mode.
D0-D7	I	External Memory Data Bus. Data is input when \overline{RCS} is low. When \overline{RCS} is high, these pins become low due to internal pull-down resistors.
\overline{IBUSY}	O	I Busy. Outputs a "L" level during voice playback (except during standby conversion time), or when the AOUT pin is at half V_{DD} level.
RA0-RA22	O	External Memory Address. These are address pins for an external memory output when \overline{RCS} is low. These pins become high impedance status if \overline{RCS} is in "H" level.
\overline{RCS}	I	Read Chip Select. The data bits D0-D7 are internally pulled down when \overline{RCS} is high. Addresses and \overline{CE} are output when \overline{RCS} is at "L" level. The RA22-RA0 address pins and \overline{CE} pin become high impedance.
\overline{STBY}	I	Standby Control. If set to "L" level, the MSM6650 enters standby mode 0.2 seconds after voice ends. If set to "H" level, the MSM6650 AOUT output maintains half V_{DD} after voice ends.
STANDBY	O	Standby Indicator. This output pin remains at "L" level during oscillation.
$\overline{TEST1,3}$	I	Test. Set these pins to "H" level. The $\overline{TEST1}$ and $\overline{TEST3}$ pins have internal pull-up resistor.
TEST2	I	Test. Set this pin to "L" level.
AGND	—	Analog ground pin.
DGND	—	Digital ground pin.
AV_{DD}	—	Analog power pin. Insert a 0.1 μ F or more bypass capacitor in between this pin and AGND.
DV_{DD}	—	Digital power pin. Insert a 0.1 μ F or more bypass capacitor in between this pin and DGND.

ABSOLUTE MAXIMUM RATINGS

(GND=0 V)

Parameter	Symbol	Condition	Rating	Unit
Power supply voltage	V_{DD}	$T_a = 25^\circ\text{C}$	-0.3 to +7.0	V
Input voltage	V_{IN}		-0.3 to $V_{DD}+0.3$	V
Storage temperature	T_{STG}	—	-55 to +150	$^\circ\text{C}$

RECOMMENDED OPERATING CONDITIONS

(GND=0 V)

Parameter	Symbol	Condition	Range			Unit
Power supply voltage	V_{DD}	MSM6652-56, MSM6650, MSM6652A-56A	+2.4 to +5.5			V
	V_{DD}	MSM6658A, MSM66P54	+3.5 to +5.5			V
Operating temperature	T_{op}	—	-40 to +85			$^\circ\text{C}$
Master clock frequency 1	f_{OSC1}	When crystal selected	Min.	Typ.	Max.	MHz
			3.5	4.096	4.5	
Master clock frequency 2	f_{OSC2}	When RC selected (note)	200	256	300	kHz

Note: Not applied to MSM66P54-XX.

ELECTRICAL CHARACTERISTICS

DC Characteristics

(V_{DD}=5.0 V, GND=0 V, Ta=-40 to +85°C)

Parameter	Symbol	Condition	Min.	Typ.	Max.	Unit
"H" input voltage	V _{IH}	—	4.2	—	—	V
"L" input voltage	V _{IL}	—	—	—	0.8	V
"H" output voltage	V _{OH}	I _{OH} =-1 mA	4.6	—	—	V
"L" output voltage	V _{OL}	I _{OL} =2 mA	—	—	0.4	V
"H" input current 1	I _{IH1}	V _{IH} =V _{DD}	—	—	10	μA
"H" input current 2	I _{IH2}	Internal pull-down resistance	30	90	200	μA
"L" input current 1	I _{IL1}	V _{IL} =GND	-10	—	—	μA
"L" input current 2 (note)	I _{IL2}	Internal pull-up resistance	-200	-90	-30	μA
Operating power consumption	I _{DD}	—	—	6	10	mA
Standby power consumption	I _{DS}	—	—	—	10	μA
D/A output relative accuracy	V _{DAE}	When D/A output selected	—	—	40	mV
D/A output impedance	R _{DAO}	When D/A output selected	15	25	35	kΩ
LPF driving resistance	R _{AOUT}	—	50	—	—	kΩ
LPF output impedance	R _{LPF}	I _F =100 μA	—	1	3	kΩ

Note: Not applied to MSM66P54-XX.

DC Characteristics

(V_{DD}=3.1 V, GND=0 V, Ta=-40 to +85°C)

Parameter	Symbol	Condition	Min.	Typ.	Max.	Unit
"H" input voltage	V _{IH}	—	2.7	—	—	V
"L" input voltage	V _{IL}	—	—	—	0.5	V
"H" output voltage	V _{OH}	I _{OH} =-1 mA	2.6	—	—	V
"L" output voltage	V _{OL}	I _{OL} =2 mA	—	—	0.4	V
"H" input current 1	I _{IH1}	V _{IH} =V _{DD}	—	—	10	μA
"H" input current 2	I _{IH2}	Internal pull-down resistance	10	30	100	μA
"L" input current 1	I _{IL1}	V _{IL} =GND	-10	—	—	μA
"L" input current 2 (note)	I _{IL2}	Internal pull-up resistance	-100	-30	-10	μA
Operating power consumption	I _{DD}	—	—	4	7	mA
Standby power consumption	I _{DS}	—	—	—	1	μA
D/A output relative accuracy	V _{DAE}	When D/A output selected	—	—	20	mV
D/A output impedance	R _{DAO}	When D/A output selected	15	25	35	kΩ
LPF driving resistance	R _{AOUT}	—	50	—	—	kΩ
LPF output impedance	R _{LPF}	I _F =100 μA	—	1	3	kΩ

Note: Not applied to MSM66P54-XX.

AC Characteristics

(Standalone Mode, $V_{DD}=5.0\text{ V}$, $GND=0\text{ V}$, $T_a=-40\text{ to }+85^\circ\text{C}$)

Parameter	Symbol	Condition	Min.	Typ.	Max.	Unit
Master clock duty cycle	f_{duty}	—	40	50	60	%
RESET input pulse width	$t_{w(\overline{RST})}$	—	10	—	—	μs
RESET input time after power-on	$t_{D(\overline{RST})}$	—	0	—	—	μs
RND input pulse width	$t_{w(\overline{RAN})}$	See Functional Description 5.2	100	—	—	μs
SW0-SW3 input pulse width	$t_{w(\text{SW})}$	—	16	—	—	ms
BUSY output time 1	t_{SBS}	—	—	—	10	μs
BUSY output time 2	t_{BN}	At $f_S=8\text{ kHz}$	350	375	400	μs
Chattering prevention time	t_{CHA}	—	14	15	16	ms
D/A converter change time	$t_{\text{DAR}}, t_{\text{DAF}}$	—	60	64	68	ms
LPF stable time	t_{L}	—	6	8	10	ms
Standby transition time	t_{STB}	—	0.15	0.2	0.25	sec
Random address capture time	t_{RA}	See Functional Description 5.2	16	32	48	μs

TIMING DIAGRAMS

Power-On Timing

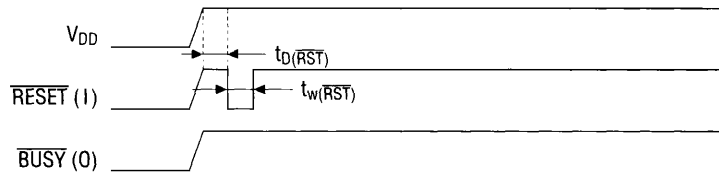

Activation of Standby State Timing

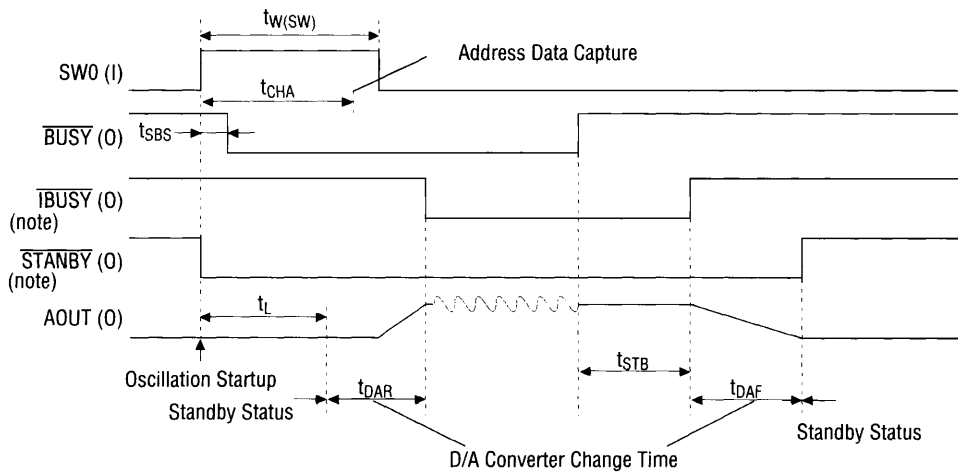

Note: $\overline{\text{IBUSY}}$, $\overline{\text{STANDBY}}$ timings are applied to MSM6650 alone.

Repeated Playback Timing

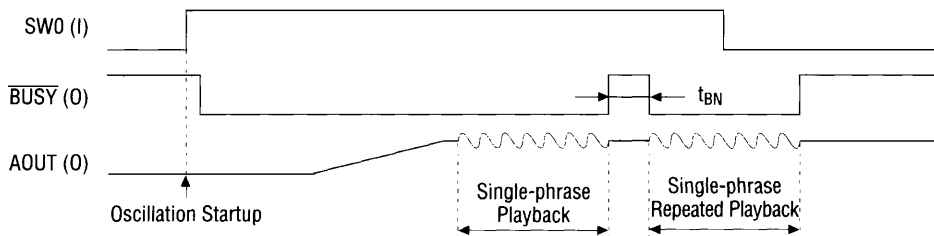

Playback Timing during Transition of SW0-SW3

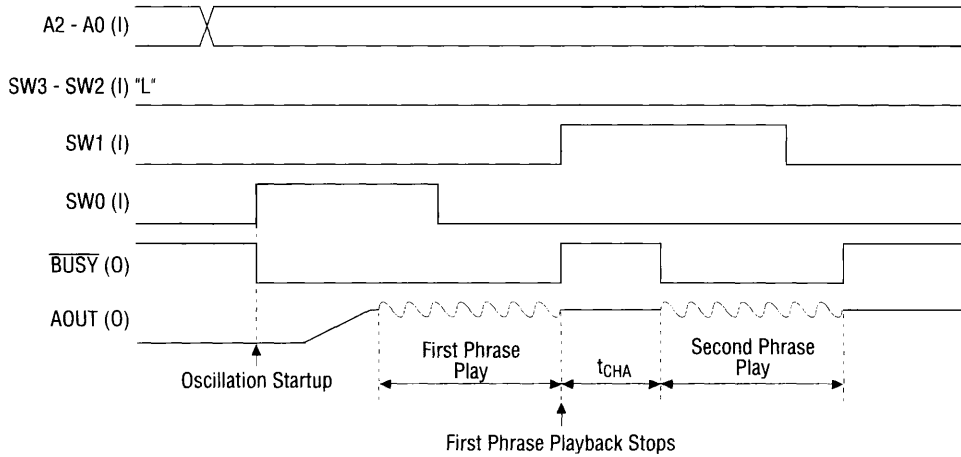

Repeated Random Playback Timing

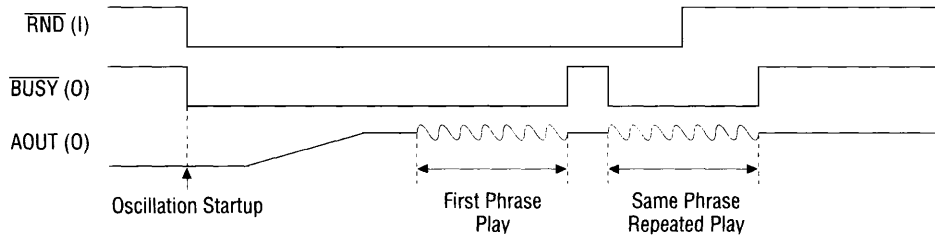

Random Address Capture Timing

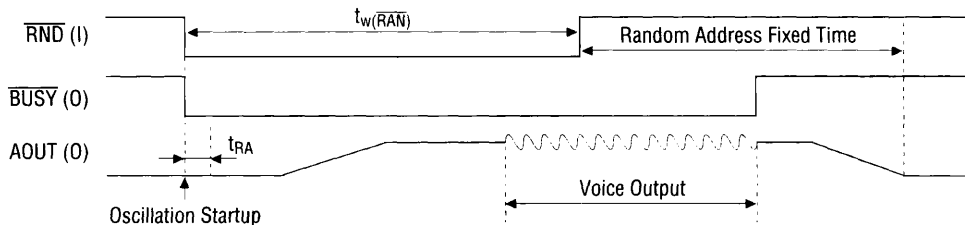

FUNCTIONAL DESCRIPTION

1. PLAYBACK CODE SPECIFICATION

The user can specify a maximum of 120 phrases. Table 1.1 shows the settings by A2-A0 and SW3-SW0.

Table 1.1 User Specified Phrase List

A2-A0	SW3-SW0	Code Description
000	0000	Inhibit code
111	0001	User Specified Phrases (120 phrases)
	1111	

2. INTERNAL ROM USAGE AND DISABLED AREA

(MSM6652/53/54/55/56-XXX, MSM6652A/53A/54A/55A/56A/58A-XXX, MSM66P54-XX)

The last 3 bytes of the internal ROM are not to be used as shown in Table 2.1. Please do not use these 3 bytes when creating the sound ROM.

Table 2.1 shows the addresses that are not to be used for each model.

Table 2.1 Internal ROM Layout and Disabled Area

Type	Voice Data Area	Disabled Area
MSM6652, 6652A	00B00-08FFC	08FFD, 08FFE, 08FFF
MSM6653, 6653A	00B00-10FFC	10FFD, 10FFE, 10FFF
MSM6654, 6654A	00B00-1FFFC	1FFFD, 1FFFE, 1FFFF
MSM6655, 6655A	00B00-2FFFC	2FFFD, 2FFFE, 2FFFF
MSM6656, 6656A	00B00-3FFFC	3FFFD, 3FFFE, 3FFFF
MSM6658A	00B00-7FFFC	7FFFD, 7FFFE, 7FFFF
MSM66P54	00B00-1FFFC	1FFFD, 1FFFE, 1FFFF

Note: Addresses are in hex.

3. PULL-UP/PULL-DOWN RESISTOR

The $\overline{\text{RESET}}$, $\overline{\text{RND}}$ and $\overline{\text{TEST}}$ pins have internal pull-up resistors and the SW3-SW0 pins have internal pull-down resistors.

Table 3.1 Pins with Pull-up/Pull-down Resistor

	Pins with pull-up	Pins with pull-down
MSM6652/53/54/55/56 MSM6652A/53A/54A/55A/56A/58A	$\overline{\text{RESET}}$, $\overline{\text{RND}}$, $\overline{\text{TEST}}$	SW3-SW0
MSM66P54	$\overline{\text{RESET}}$, $\overline{\text{RND}}$, $\overline{\text{TEST}}$	SW3-SW0
MSM6650	$\overline{\text{RESET}}$, $\overline{\text{RND}}$, $\overline{\text{TEST}}_{1, 3}$	SW3-SW0

4. OPTION(S)

In standalone mode the XT/ $\overline{\text{CR}}$ pin can be used to select the oscillation circuit. If this pin is set to "H" level, the circuit is in ceramic oscillation, conversely, if set to "L" level, the circuit is in RC oscillation.

In the case of RC oscillation, however, a 32 kHz sampling frequency cannot be used.
An option to move to standby mode can be selected when rewriting ROM data.

5. STANDALONE MODE

In standalone mode, the SW input interface function and the random playback function can be used.

5.1 SW Input Interface

With the SW input interface, voice synthesis starts when SW3-SW0 pins have changed. To prevent chattering, the address is captured 16 ms (t_{CHA}) after SW3-SW0 pins have changed. Voice synthesis does not start if A2-A0 pins have changed.

Set the $\overline{\text{RND}}$ pin to "H" level if the random playback function is not used.

At power on, SW3-SW0 pins are all "L" level.

The SW input interface is effective when operating the MSM665X using a push button switch.

Speech synthesis starts when an address is changed by pressing the push-button switch. If the push-button switch is released during playback, then playback stops after the current phrase is completed.

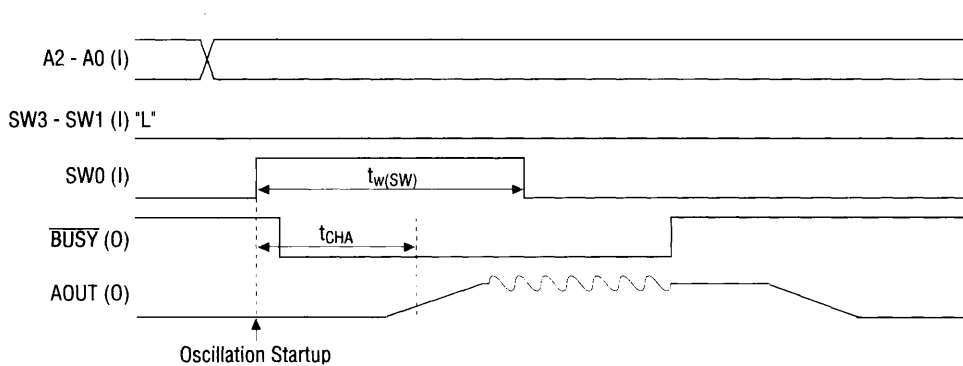

Figure 5.1 SW Input Interface – Single Phrase Playback Timing

Figure 5.1 shows single phrase playback timing.

If a push-button switch is continuously pushed, the same phrase is played repeatedly. Figure 5.2 shows repeated playback timing. Figure 5.3 shows timing when A2-A0 are changed during playback.

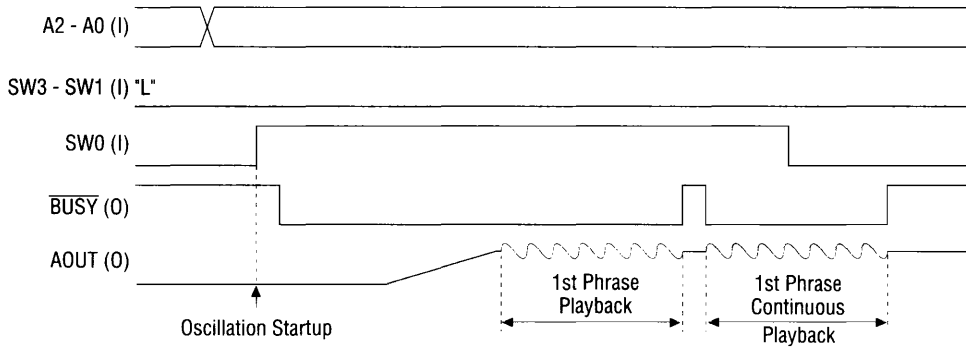

Figure 5.2 SW Input Interface – Repeated Playback Timing

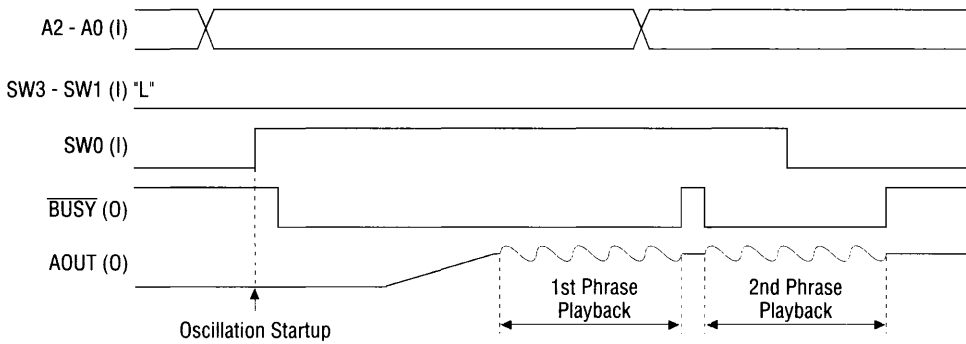

Figure 5.3 SW Input Interface Playback Timing

If SW3-SW0 pins change during playback, then playback stops and the next phrase is played. For the next phrase playback, the voice is first stopped and playback occurs after 16 ms of chattering prevention.

Figure 5.4 shows timing when SW3-SW0 are changed during playback.

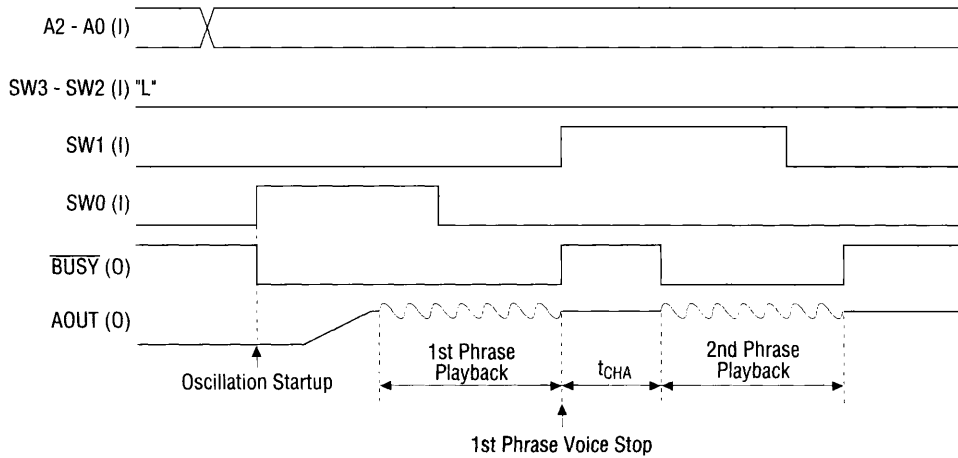

Figure 5.4 Timing when SW3-SW0 are Changed during Playback

If playback is attempted at an unused address in the phrase ROM, then AOUT goes to $1/2 V_{DD}$ and playback does not occur. Figure 5.5 shows the timing.

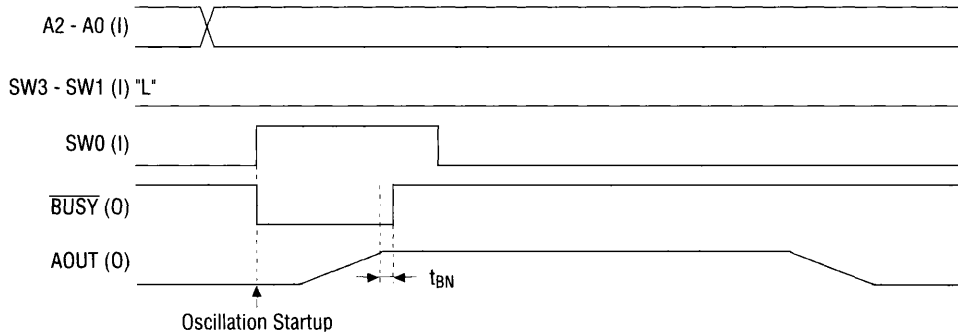

Figure 5.5 Timing when Playback is Attempted at an Unused Phrase Address

In the SW interface, addresses (against SW3-SW0) that do not start up voice playback exist without fail. When power is turned ON or when input to \overline{RESET} , the addresses set from SW3 to SW0 become the addresses that do not start up voice playback. Therefore, when the circuit consists of diode matrixes that use push-button switches, the maximum playback phrases become 120 phrases.

Combinations of A2-A0 are eight kinds.

When addresses of SW3-SW0 that do not start up voice playback are 0000;
 $2^7 - 8 = 120$ (phrases)

5.2 Random Playback Function

The random playback function generates 31 random addresses corresponding to the 5 bits of the addresses of A0, and SW3-SW0 (except ALL "L") on the IC, after which playback commences.

This means there is no external input to the A0, SW3-SW0 pins. Since the A0 pin has no internal pull-up/pull-down resistor, permanently set to "L" or "H".

Playback will not occur if none of the 31 addresses have been assigned a phrase. Caution is advised when creating ROM data.

For example, when four phrases, "sunny", "rainy", "cloudy", and "snowy" are to be played, set the phrases as shown in Table 5.1 to 31 random addresses. The four phrases are then played at random as shown below.

Table 5.1 Random Address Setup Example

A2, A1	A0, SW3-SW0	Phrase
00	00001	Sunny
	00010	Rainy
	00011	Cloudy
	00100	Snowy
	00101	Sunny
	}	}
	11110	Rainy
	11111	Snowy

Random playback occurs in accordance with the timing shown in Figure 5.6. The random address is captured at the fall of the $\overline{\text{RND}}$ pin, and voice playback commences. When power is turned ON, or when $\overline{\text{RESET}}$ is input, the phrase at address "00001" is played while a random counter remains initialized until random playback is initiated.

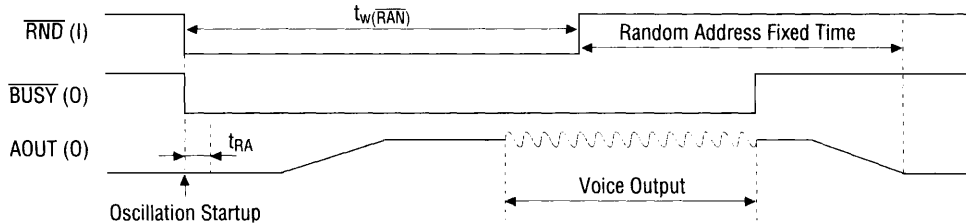

Figure 5.6 Random Address Capture

Table 5.2 Addresses for Random Play

A2, A1	A0, SW3-SW0 (Note)	Code Description
00	00001 } 11111	Random Playback Address (31 Types)
01	Same as above	Same as above
10		
11		

Note: Address(es) corresponding to A0, SW3-SW0 pins.

For a random address, 31 phrases can be set for each LOGICAL condition of addresses A2 and A1 (i.e., "00", "01", "10", and "11").

In random playback, note that the four logic states (00, 01, 10, 11) in user specified phrases cannot be used when the phrase ROM data is prepared.

A random address is set by the "H" level time of the \overline{RND} pin, so if the same pulse width is input by microcontroller, the random address fixed time becomes constant, and a "random" phrase may not be played under these conditions. The random address fixed time must be inconsistent in order to produce random playback.

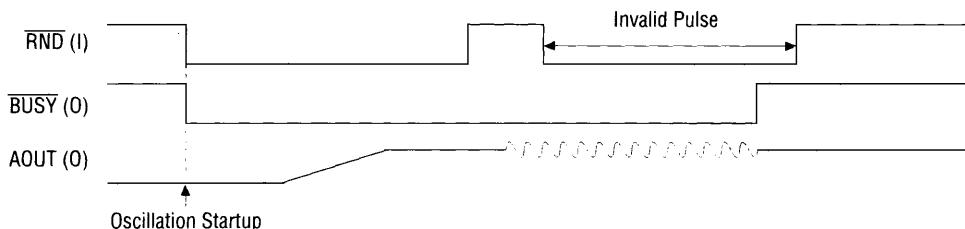

Figure 5.7 Timing when a Pulse is Input to the \overline{RND} Pin during Random Play

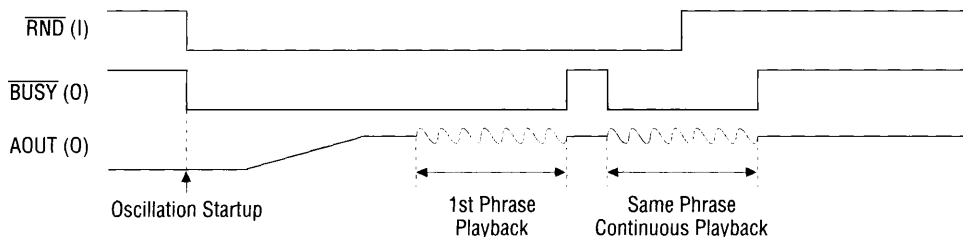

Figure 5.8 Repeat Playback Timing of Random Play

As shown in Figure 5.7, if a pulse is input to the \overline{RND} pin during voice playback (\overline{BUSY} is "L" level), that pulse becomes invalid. If the \overline{RND} pin remains "L" level after phrase playback has been completed, then the same phrase is repeated, as shown in Figure 5.8.

If SW3-SW0 are changed during random playback, voice playback stops, and voice data that corresponds to SW3-SW0 is played.

Figure 5.9 shows the timing when SW3-SW0 are changed during random play.

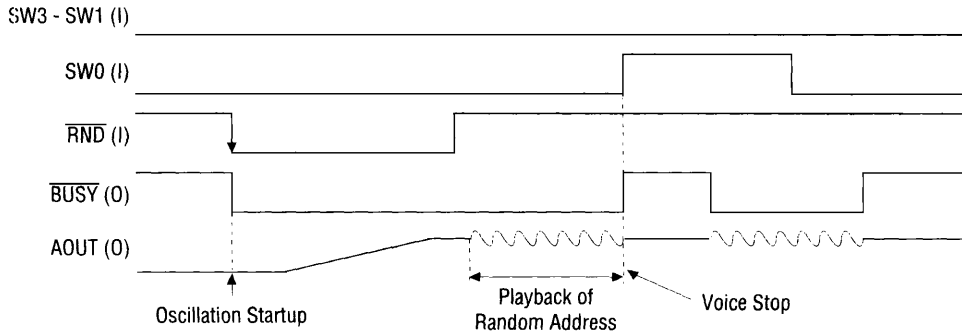

Figure 5.9 Timing when a Pulse is Input to the SW0 Pin during Random Playback

Table 5.3 and Figure 5.10 show the address settings that stop random playback. These settings also stop playback when the "infinite repeat" command is used during edit ROM playback.

Table 5.3 Random Play and Stop Addresses

A2, A1	A0, SW3-SW0 (Note)	Code Description
00	00001 } 11111	Random Play Address (31 Types)
01	00001	Stop Address

Note: Addresses corresponding to A0, SW3-SW0 pins.

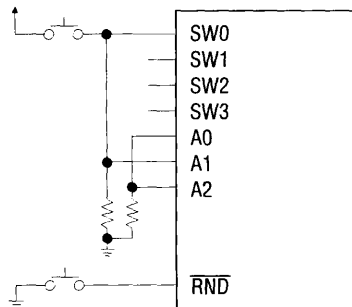

Figure 5.10 Circuit Example for Random Play Stop

6. SAMPLING FREQUENCY

Sampling frequencies can be specified for each phrase in the voice data of the internal ROM. For channel synthesis, if channels 1 and 2 are played simultaneously, the channel 1 sampling frequency has priority.

The following eight frequencies can be selected when creating voice data.

4.0 kHz, 5.3 kHz, 6.4 kHz, 8.0 kHz, 10.6 kHz, 12.8 kHz, 16.0 kHz, 32.0 kHz

In standalone, RC oscillation or ceramic oscillation can be selected. If RC oscillation is selected however, 32.0 kHz sampling cannot be selected.

7. VOICE PLAYBACK TIME

Table 7.1 shows internal ROM configuration. The actual voice data ROM area is different from the indicated ROM capacity.

The voice data management area shown in Table 7.1 is about 6 Kbits, and the edit ROM area includes 16 Kbits.

Table 7.1 ROM Configuration

Voice Data Management Area
Edit ROM Area
Voice Data Area
Disabled Area

Use the following formula as a guide to compute voice playback time.

$$\text{Playback Time} = (\text{ROM Capacity} - 16 - 6) \times 1024 \times 255 / 256 \div \text{Data Rate (kbps)}$$

For example, if data was created at a 4.0 kHz sampling rate using the MSM6652 (288-Kbit ROM), the playback time is

$$(288 - 16 - 6) \times 1024 \times 255 / 256 \div 16 \text{ (kbps)} = 16.9 \text{ (sec.)}$$

8. CHANNEL STATUS

The $\overline{\text{BUSY}}$ pin outputs the status signals. It outputs "L" level when either channel 1 or 2 is playing voice. "H" level is output when power is turned ON.

9. PLAYBACK METHOD

The MSM6375 family uses the ADPCM playback method, however the MSM6650 family has three playback methods: ADPCM, PCM and melody playback. The respective features and selection criteria are explained below.

9.1 ADPCM Method

With the ADPCM (adaptive differential pulse-code modulation) method, basic quantization width Δ is adaptively changed for each sampling, and is encoded to 4-bit data each time. This further improves the follow-up properties to speech wave forms.

Conversion to ADPCM data is performed by the development tool AR761 or AR762.

ADPCM is a compression algorithm which provides the best compromise between quality (bandwidth) and memory usage (data rate). ADPCM can be used for accurate reproduction of voice, music, and sound effects.

9.2 PCM Method

The PCM method of the MSM6650 family uses an 8-bit straight binary format. Of the three methods, PCM is best suited to accurate reproduction of sound effects or waveforms which are pulse shaped or change rapidly (such as high frequency pure tone sine-waves).

9.3 Melody Playback Method

The AR761 and AR762 development tools support melody regeneration system. The melody data can be composed by using these tools. Therefore, unique sound can be created.

9.4 Data Rate of Each Method

The data rate shows the degree of data compression and the data amount to synthesize for 1 second. The data rate is determined by the relationship between the sampling frequency and the format (number of bits per sample). The following formula is used.

$$\text{Data rate (kbps)} = \text{Sampling frequency (kHz)} \times \text{Number of bits per sample}$$

The data rate of the three methods are compared below when the sampling frequency is 6.4 kHz.

1) ADPCM Method

$$\text{Data Rate (kbps)} = 6.4 \text{ (kHz)} \times 4 \text{ (bit)} = 25.6 \text{ (kbps)}$$

2) PCM Method

$$\text{Data Rate (kbps)} = 6.4 \text{ (kHz)} \times 8 \text{ (bit)} = 51.2 \text{ (kbps)}$$

3) Melody Playback Method

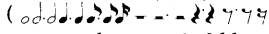
With the melody playback method, the data rate changes depend on the tempo or the kind of note () used. The formula does not determine the data rate changes. The average data rate is 8 kbps.

The data rate of the melody playback method is calculated as follows:

$$\text{Data rate} = \text{number of notes per second} \times \text{data amount per note [kbits]}$$

For example, to obtain data rate from the following conditions,

$$f_s = 6.4 \text{ kHz}$$

$$\text{Number of notes per second} = 1$$

$$\text{Time [seconds] taken for each thirty-second note} = 0.083 \text{ sec (Tempo} = 90)$$

first, obtain the data amount per note with the following expression:

$$\begin{aligned} \text{Data amount per note [kbits]} &= \text{data amount per thirty-second note [bits per note]} \times 2 \\ &= \text{Time taken for each thirty-second} \\ &\quad \text{note [sec]} \times f_s \text{ [Hz]} \times 8 \text{ [bits]} \times 2 \\ &= 0.083 \times 6400 \times 8 \times 2 \\ &\approx 8.5 \text{ [kbits]} \end{aligned}$$

Therefore, when the number of notes per second is 1, the data rate is approximately 8.5 kbps.

9.5 Channel Synthesis Combinations for Each Playback Method

Melody and Beep Tone playback is in channel 1 only.

Table 9.1 Channel Synthesis Combinations

1 Channel	2 Channel	Setting
VOICE (0 dB)	VOICE (0 dB to -18 dB)	○ (note1)
VOICE (0 dB to -18 dB)	VOICE (0 dB)	○ (note1)
VOICE (-6 dB to -18 dB)	VOICE (-6 dB to -18 dB)	○
VOICE (0 dB to -18 dB)	MELODY (0 dB to -18 dB)	×
VOICE (0 dB to -18 dB)	PCM (0 dB)	○ (note1)
VOICE (0 dB)	PCM (0 dB to -18 dB)	○ (note1)
VOICE (-6 dB to -18 dB)	PCM (-6 dB to -18 dB)	○
VOICE (0 dB to -18 dB)	BEEP TONE (1/2, 1/3, 1/4, 1/8)	×
VOICE (0 dB to -18 dB)	SILENCE	○
MELODY (0 dB)	VOICE (0 dB to -18 dB)	○ (note1)
MELODY (0 dB to -18 dB)	VOICE (0 dB)	○ (note1)
MELODY (-6 dB to -18 dB)	VOICE (-6 dB to -18 dB)	○
MELODY (0 dB to -18 dB)	MELODY (0 dB to -18 dB)	×
MELODY (0 dB)	PCM (0 dB to -18 dB)	○ (note1)
MELODY (0 dB to -18 dB)	PCM (0 dB)	○ (note1)
MELODY (-6 dB to -18 dB)	PCM (-6 dB to -18 dB)	○
MELODY (0 dB to -18 dB)	BEEP TONE (1/2, 1/3, 1/4, 1/8)	×
MELODY (0 dB to -18 dB)	SILENCE	○
PCM (0 dB)	VOICE (0 dB to -18 dB)	○ (note1)
PCM (0 dB to -18 dB)	PCM (0 dB)	○ (note1)
PCM (-6 dB to -18 dB)	PCM (-6 dB to -18 dB)	○
PCM (0 dB to -18 dB)	MELODY (0 dB to -18 dB)	×
PCM (0 dB)	PCM (0 dB to -18 dB)	○ (note1)
PCM (0 dB to -18 dB)	PCM (0 dB)	○ (note1)
PCM (-6 dB to -18 dB)	PCM (-6 dB to -18 dB)	○
PCM (0 dB to -18 dB)	BEEP TONE (1/2, 1/3, 1/4, 1/8)	×
PCM (0 dB to -18 dB)	SILENCE	○
BEEP TONE (1/2, 1/3, 1/4, 1/8)	VOICE (0 dB)	○ (note1)
BEEP TONE (1/2, 1/3, 1/4, 1/8)	VOICE (-6 dB to -18 dB)	○
BEEP TONE (1/2, 1/3, 1/4, 1/8)	MELODY (0 dB to -18 dB)	×
BEEP TONE (1/2, 1/3, 1/4, 1/8)	PCM (0 dB)	○ (note1)
BEEP TONE (1/2, 1/3, 1/4, 1/8)	PCM (-6 dB to -18 dB)	○
BEEP TONE (1/2, 1/3, 1/4, 1/8)	BEEP TONE (1/2, 1/3, 1/4, 1/8)	×
BEEP TONE (1/2, 1/3, 1/4, 1/8)	SILENCE	○
SILENCE	VOICE (0 dB to -18 dB)	○
SILENCE	MELODY (0 dB to -18 dB)	×
SILENCE	PCM (0 dB to -18 dB)	○
SILENCE	BEEP TONE (1/2, 1/3, 1/4, 1/8)	×
SILENCE	SILENCE	○

Note 1. In the case of channel synthesis, verify the voice quality with the MSM6650 evaluation board. The combination of channels 1 and 2 can sometimes cause clipping is either of the channels is recorded at a level which is too high.

10. STANDBY CONVERSION

When standby conversion is selected by MASK option, if the next phrase does not start within 200 ms after voice ends, the IC enters standby status and all operation stops. If restarted, it takes about 100 ms from startup to voice start because the "pop noise" suppression circuit is in operation.

If standby conversion is not selected by the MASK option, the IC does not enter standby status even if voice playback has ceased. Current is drawn since AOUT remains at about $1/2 V_{DD}$ and oscillation is in operation. If restarted, playback occurs after 350 μ s. To enter standby status when standby conversion is not selected, the RESET pulse must be input.

If the $\overline{\text{RESET}}$ pulse is input, the output level at AOUT instantaneously goes to GND level, causing pop noises.

Table 10.1 Standby Conversion

	Pin Name	Standby Conversion Selected	No Standby Conversion Selected
MSM6652/53/54/55/56, MSM6652A/53A/54A/55A/56A/58A	—	Mask option	
MSM66P54	—	-03 code	-04 code
MSM6650	$\overline{\text{STBY}}$	"L"	"H"

11. VOICE OUTPUT

In standalone mode speech is output via an internal low-pass filter (LPF). Table 12.1 shows output level of AOUT pin. This filter consists of switched capacitors. Table 12.2 shows the relationship between sampling frequencies and cutoff frequencies.

Table 11.1 Output Level of AOUT Pin

Playback Method	Lowest Level	Center Level	Highest Level
ADPCM	approx. $0.15 \times V_{DD}$	approx. $0.5 \times V_{DD}$	approx. $0.95 \times V_{DD}$
PCM	approx. $0.25 \times V_{DD}$	approx. $0.5 \times V_{DD}$	approx. $0.75 \times V_{DD}$
Melody	approx. $0.25 \times V_{DD}$	approx. $0.5 \times V_{DD}$	approx. $0.75 \times V_{DD}$
BEEP Tone	approx. $0.25 \times V_{DD}$	approx. $0.5 \times V_{DD}$	approx. $0.75 \times V_{DD}$

Table 11.2 Cutoff Frequencies of Low Pass Filter

Sampling Frequency (f_s)	Cutoff Frequency (f_{cut})
4.0 kHz	approx. 1.8 kHz
5.3 kHz	approx. 2.6 kHz
6.4 kHz	approx. 2.6 kHz
8.0 kHz	approx. 3.2 kHz
10.6 kHz	approx. 4.2 kHz
12.8 kHz	approx. 5.1 kHz
16.0 kHz	approx. 6.4 kHz
32.0 kHz	approx. 12.8 kHz

Each device of the MSM6650 family contains a 4-order LPF using the switched capacitor filter technology. The attenuation is -40 dB/oct.

The cutoff frequency and LPF frequency change depending on the sampling frequency (f_s). The cutoff frequency is 0.4 time as low as the sampling frequency.

The LPF frequency characteristics at $f_s = 8$ kHz are shown below.

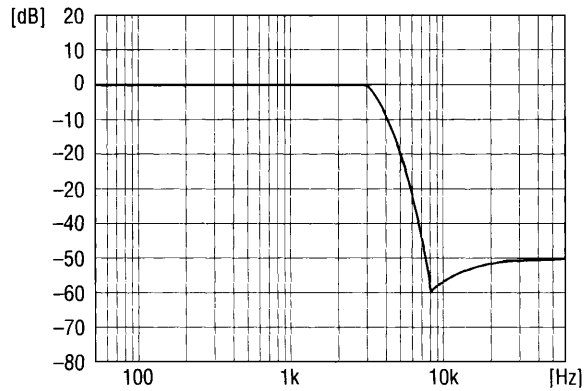

LPF frequency characteristics

12. LOW-PASS FILTER POP NOISE

Each device of the MSM6650 family contains a "pop" noise killer circuit.

However, a low-pass filter selected may cause "pop" noise as the filter output's circled portions of the figure 12.1 change by approx. 0.7 V abruptly.

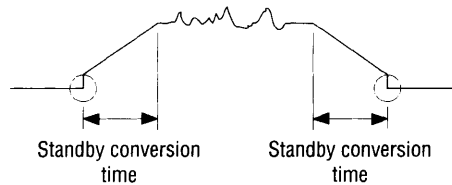

Figure 12.1 Pop Noise of Low-Pass Filter

"Pop" noise can be reduced by connecting a diode at the AOUT output (as shown below).

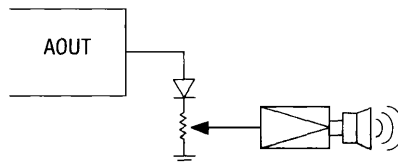

Figure 12.2 Pop Noise Killer Circuit

13. RC OSCILLATION

Figure 13.1 shows an external circuit diagram using RC oscillation.

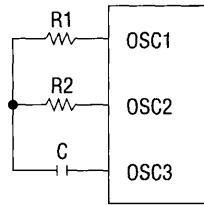

Figure 13.1 RC Oscillation

13.1 Determining RC Constants

The RC oscillation frequency characteristics are shown in Figures 13.2, 13.3, and 13.4. If f_{OSC} is set to 256 kHz, refer to the following values to set the C and R2 based on the printed-circuit board type.

R1 = 100 k Ω , R2 = 30 k Ω , C = 30 pF	(MSM6652/53/54/55/56-XXX, MSM6652A/ 53A/54A/55A/56A/58A-XXX)
R1 = 100 k Ω , R2 = 25 k Ω , C = 20 pF	(MSM66P54-XX)
R1 = 150 k Ω , R2 = 45 k Ω , C = 10 pF	(MSM6650)

When choosing RC oscillation, the RC oscillation frequency varies according to the fluctuation of the external C and R2.

13.2 Fluctuation of RC Oscillation Frequencies

When using a 30 k Ω R2, the error due to process variations of the IC is $\pm 4\%$ maximum so that the fluctuation of the RC oscillation frequency when using a capacitor (C) of $\pm 1\%$ accuracy and a resistor (R2) of $\pm 2\%$ accuracy is a maximum of $\pm 7\%$ approximately.

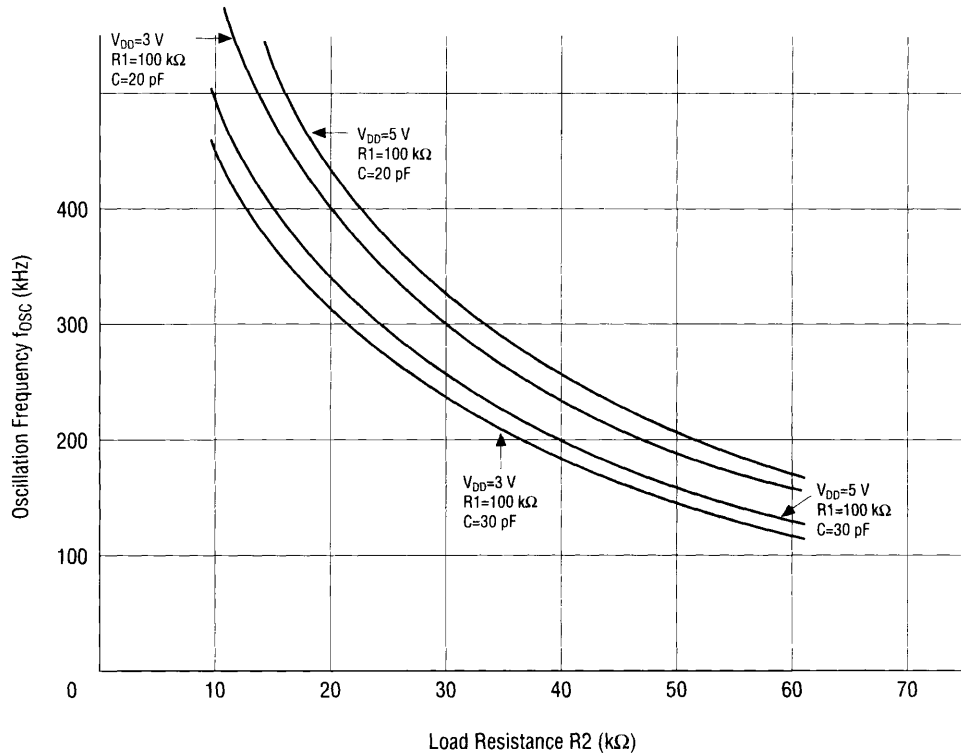

Figure 13.2 RC Oscillation Frequency Characteristics
(MSM6652/53/54/55/56-XXX, MSM6652A/53A/54A/55A/56A/58A-XXX)

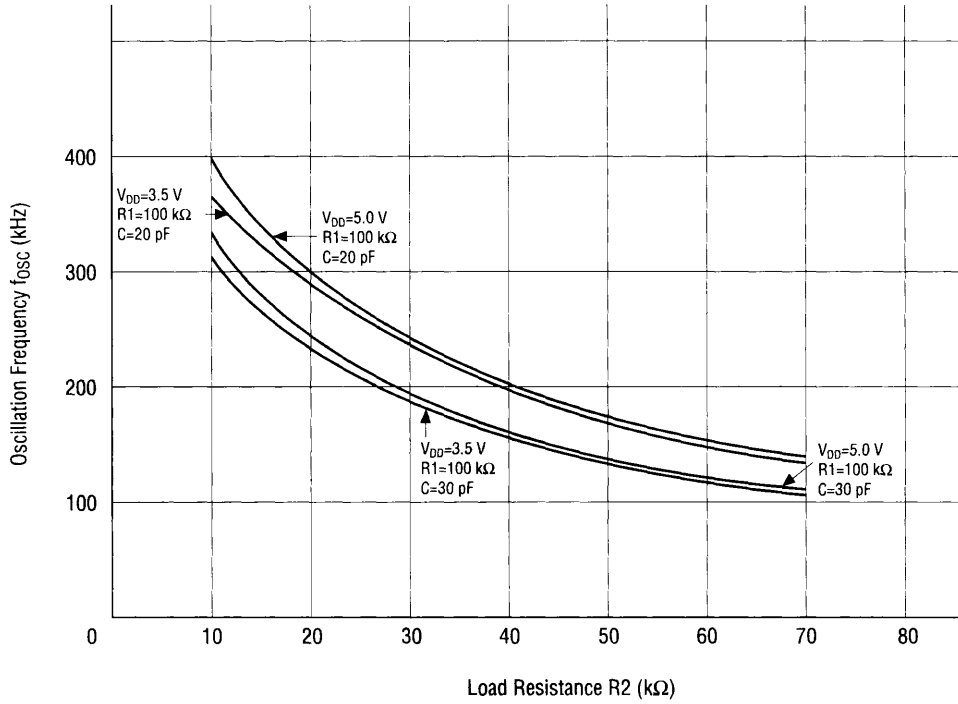

Figure 13.3 RC Oscillation Frequency Characteristics (MSM66P54)

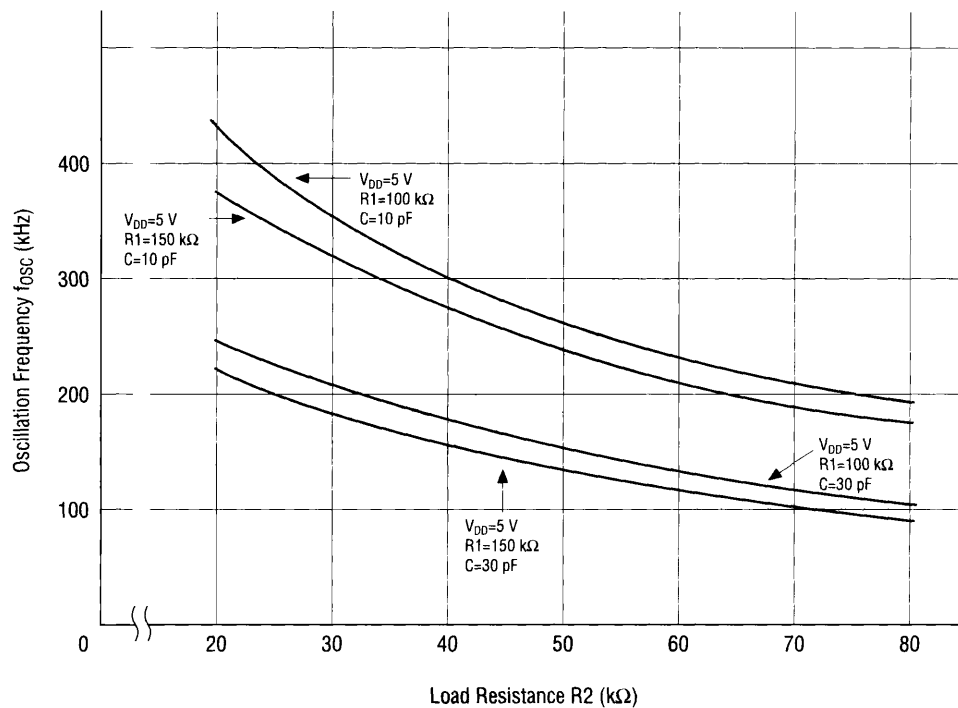

Figure 13.4 RC Oscillation Frequency Characteristics (MSM6650)

14. CERAMIC OSCILLATION

Figure 14.1 shows an external circuit diagram using a ceramic oscillation.

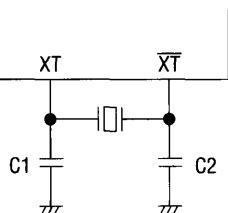

Figure 14.1 External Circuit Diagram

Figures 14.2 and 14.3 show external circuit diagrams using a ceramic oscillator, CSA4.09MGU and CST4.09MGWU made by Murata MFG. Co., Ltd.

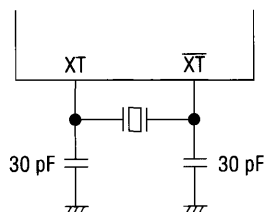

Figure 14.2 CSA4.09MGU

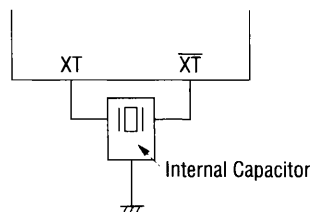

Figure 14.3 CST4.09MGWU

Figure 14.4 shows an extend circuit diagram using a ceramic oscillator, PBRC4.00MSA/MKS/MWS made by Kyocera Corp.

When using an oscillator, 4.00 MHz, playback speed is approximately 2% slower than the speed when using the development tools AR761 and AR762 and demonstration board.

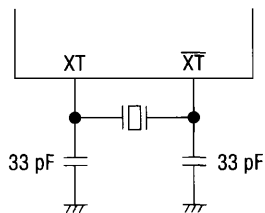
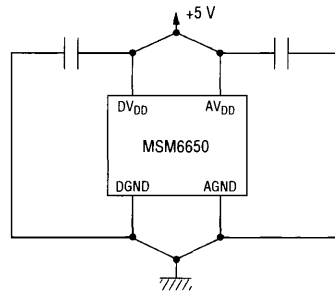

Figure 14.4 PRBC4.00MSA/MKS/MWS

15. POWER SUPPLY (For MSM6650)

The MSM6650 should be powered from a single power source to the analog section and digital section separately, as shown below.



The following power connections are not permitted.

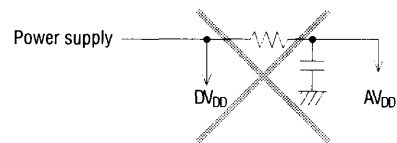
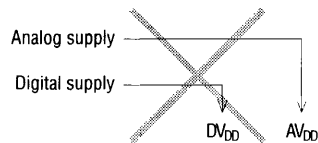

APPLICATION CIRCUITS

(MSM6652/53/54/55/56-XXX, MSM6652A/53A/54A/55A/56A/58A-XXX, MSM66P54-XX)

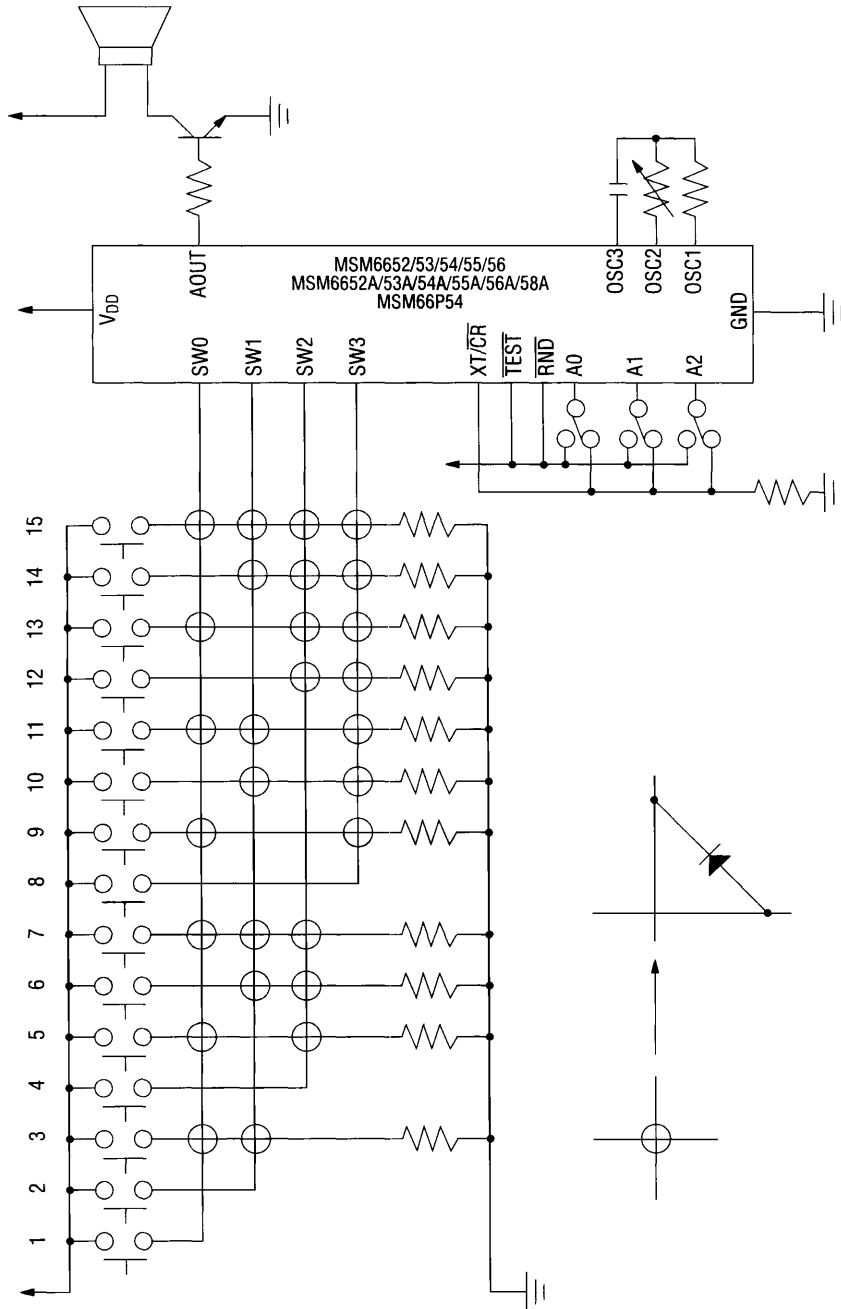

Application Circuit in Standalone Mode Supporting 15 Switch-Selected Phrases

(MSM6652/53/54/55/56-XXX, MSM6652A/53A/54A/55A/56A/58A-XXX, MSM66P54-XX)
 (Continued)

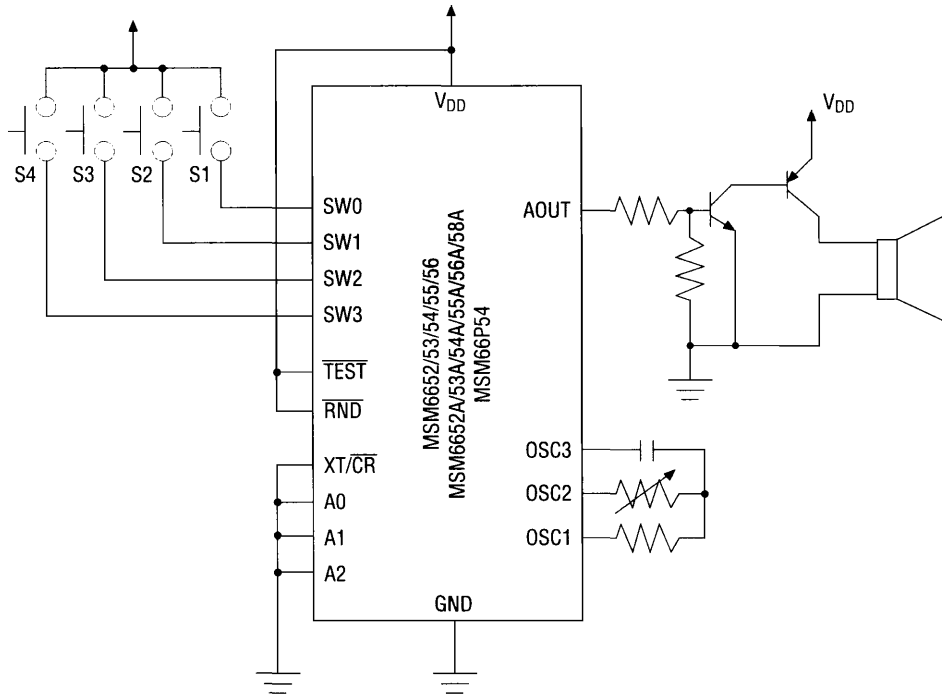

Application Circuit in Standalone Mode Supporting Four Switch-Selected Words

Switches and Playback Addresses

	A2	A1	A0	SW3	SW2	SW1	SW0	ADR
S1	0	0	0	0	0	0	1	01
S2	0	0	0	0	0	1	0	02
S3	0	0	0	0	1	0	0	04
S4	0	0	0	1	0	0	0	08

(MSM6650)

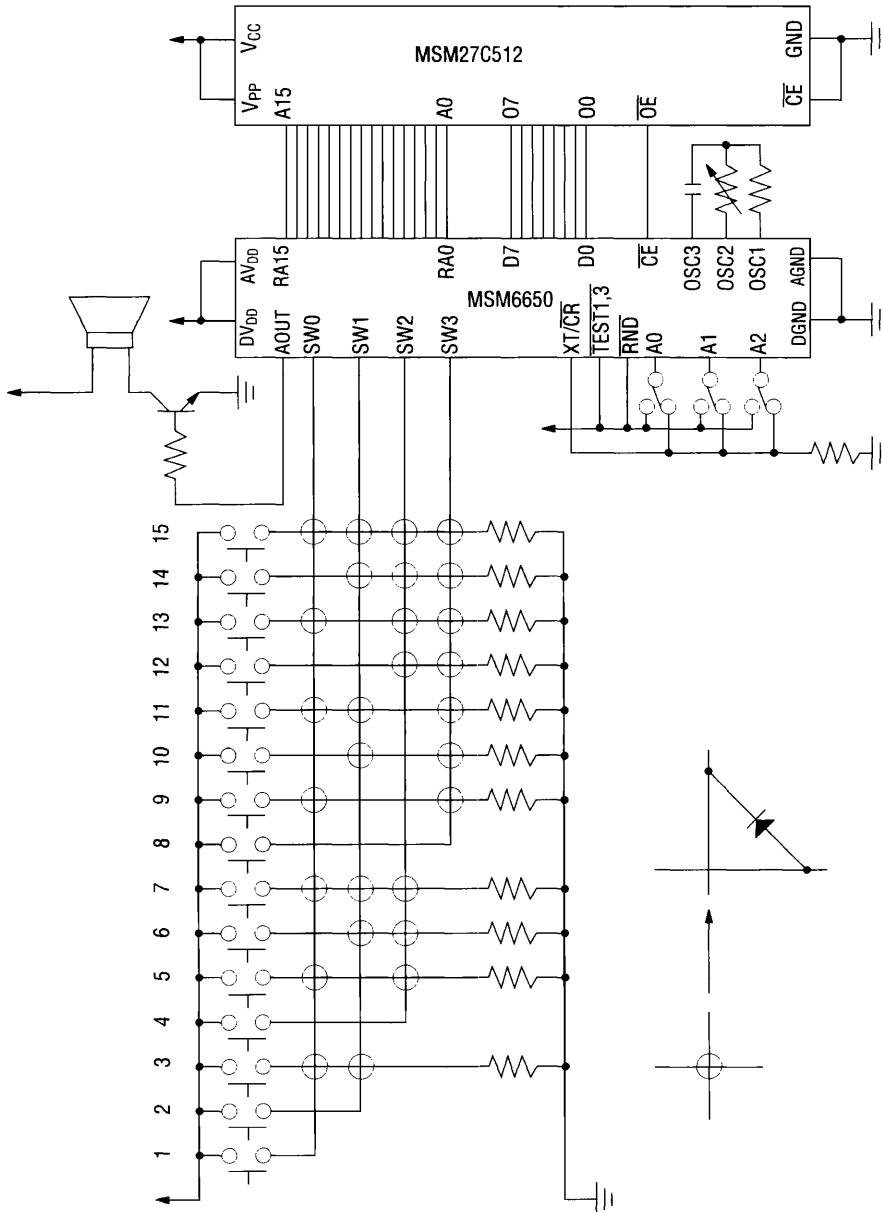

Application Circuit in Standalone Mode Supporting 15 Switch-Selected Phrases

(MSM6650) (Continued)

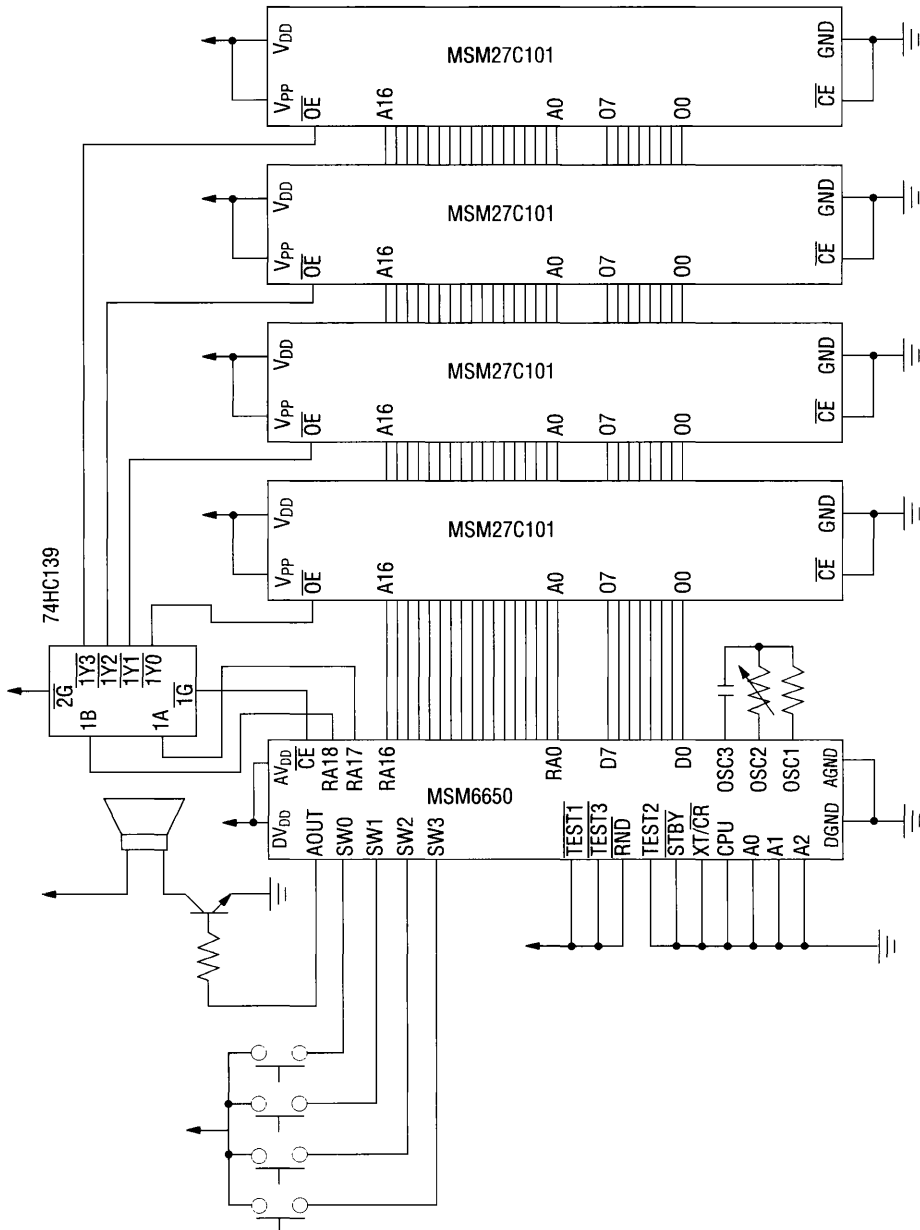

Application Circuit in Standalone Mode Supporting Four 1-Mbit EPROMs

MICROCONTROLLER INTERFACE MODE

FEATURES

Device name	Data ROM size	Maximum playback time (sec)				
		f _s =4.0 kHz	f _s =6.4 kHz	f _s =8.0 kHz	f _s =16 kHz	f _s =32 kHz
MSM6652, 6652A	288 Kbits	16.9	10.5	8.4	4.2	2.1
MSM6653, 6653A	544 Kbits	31.2	19.5	15.6	7.8	3.9
MSM6654, 6654A	1 Mbit	63.8	39.9	31.9	15.9	7.9
MSM6655, 6655A	1.5 Mbits	96.5	60.3	48.2	24.1	12.0
MSM6656, 6656A	2 Mbits	129.1	80.7	64.5	32.2	16.1
MSM6658A	4 Mbits	259.7	162.9	129.8	64.9	32.4
MSM66P54	1 Mbit	63.8	39.9	31.9	15.9	7.9
MSM6650	64 Mbits (Max)	4194.3	2620.5	2096.4	1048.2	524.1

Note: Actual voice ROM area is smaller by 22 Kbits.

- 4-bit ADPCM or 8-bit PCM sound generation
- Melody function
- Edit ROM function
- Two-channel mixing function
- Fade-out function via four-step sound volume attenuation
- Serial input or parallel input selectable
- Built-in beep tone of 0.5 kHz, 1.0 kHz, 1.3 kHz, or 2.0 kHz selectable with a specific code
- Sampling frequency of 4.0 kHz, 5.3 kHz, 6.4 kHz, 8.0 kHz, 10.6 kHz, 12.8 kHz, 16.0 kHz, or 32.0 kHz (32 kHz sampling is not possible when using RC oscillation)
- Up to 127 phrases
- Built-in 12-bit D/A converter
- Built-in -40 dB/octave low-pass filter
- Standby function
- Package options:
 - MSM6652/53/54/55/56: 18-pin plastic DIP (DIP18-P-300)
(not applied to MSM6658A)
 - MSM6652A/53A/54A/55A/56A/58A: 24-pin plastic SOP (SOP24-P-430-VK)
 - MSM66P54: 20-pin plastic DIP (DIP20-P-300-W1)
24-pin plastic SOP (SOP24-P-430-VK)
 - MSM6650: 64-pin plastic QFP (QFP64-P-1420-BK)
64-pin plastic SDIP (SDIP64-P-750)

• Option Table

	Pin Name	Microcontroller Interface Mode		Standalone Mode		
		Serial Input	Parallel Input	With Standby	No Standby	
MSM6652/53/54/55/56 MSM6652A/53A/54A/55A/56A/58A	—	Mask Option				(Note1)
MSM66P54	—	-01	-02	-03	-04	(Note2)
MSM6650	CPU	"H"	"H"	"L"	"L"	
	SERIAL	"H"	"L"	"L"	"L"	
	STBY	"H"	"H"	"L"	"H"	

- Note: 1. Mask ROM-based devices are mask optioned. The user should send OKI an option list before starting development.
A sample of option list is shown below.
2. A code of OTP version device corresponds to one of the options. The user should specify either MSM66P54-01 or MSM66P54-02. (In this case, no option list is required.)

Oki Electric Industry Co., Ltd. Date: _____

Option List

You are requested to develop MSM665X-XXX on the following conditions.

1. Options
There are four options for the MSM6650 family.
Choose and circle the desired option.

Option	Interface mode	Input	Standby conversion
Option A	Microcontroller	Serial	—
Option B	Microcontroller	Parallel	—
Option C	Standalone	—	Yes
Option D	Standalone	—	No

2. Package and quantity

Item	Package (circle the desired one)			Quantity	Note
Ceramic sample	18-pin DIP (ceramic)	24-pin SOP (ceramic)	chip	___ pcs	Up to 10 samples. Operating temp. : 10 to 30°C
Mold sample	18-pin DIP (plastic)	24-pin SOP (plastic)	chip	___ pcs	Up to 50 samples
Mass production	18-pin DIP (plastic)	24-pin SOP (plastic)	chip	___ pcs per lot monthly	

Signed by _____
Title : _____
Company name : _____

BLOCK DIAGRAMS

MSM6652/53/54/55/56-XXX

MSM6652A/53A/54A/55A/56A/58A-XXX

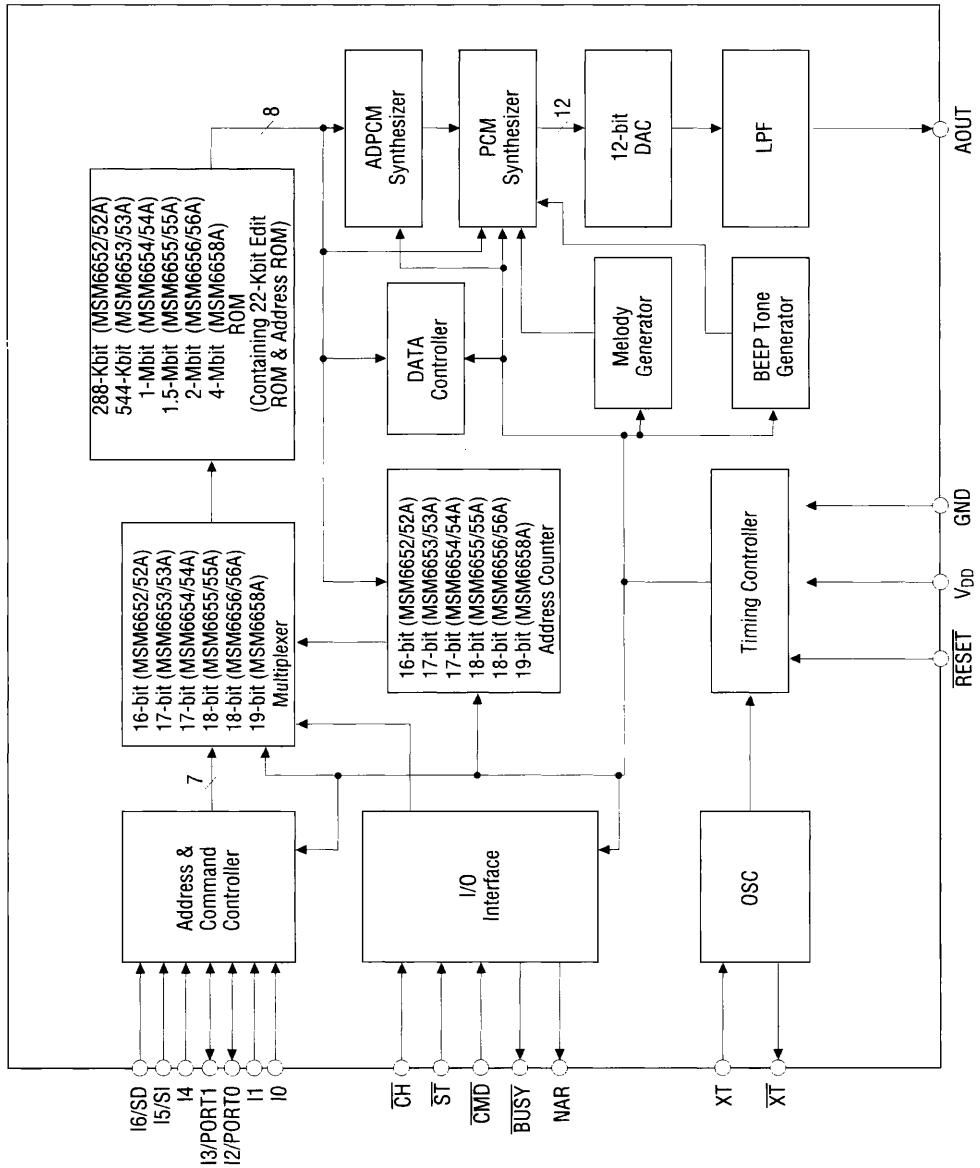

MSM66P54-XX

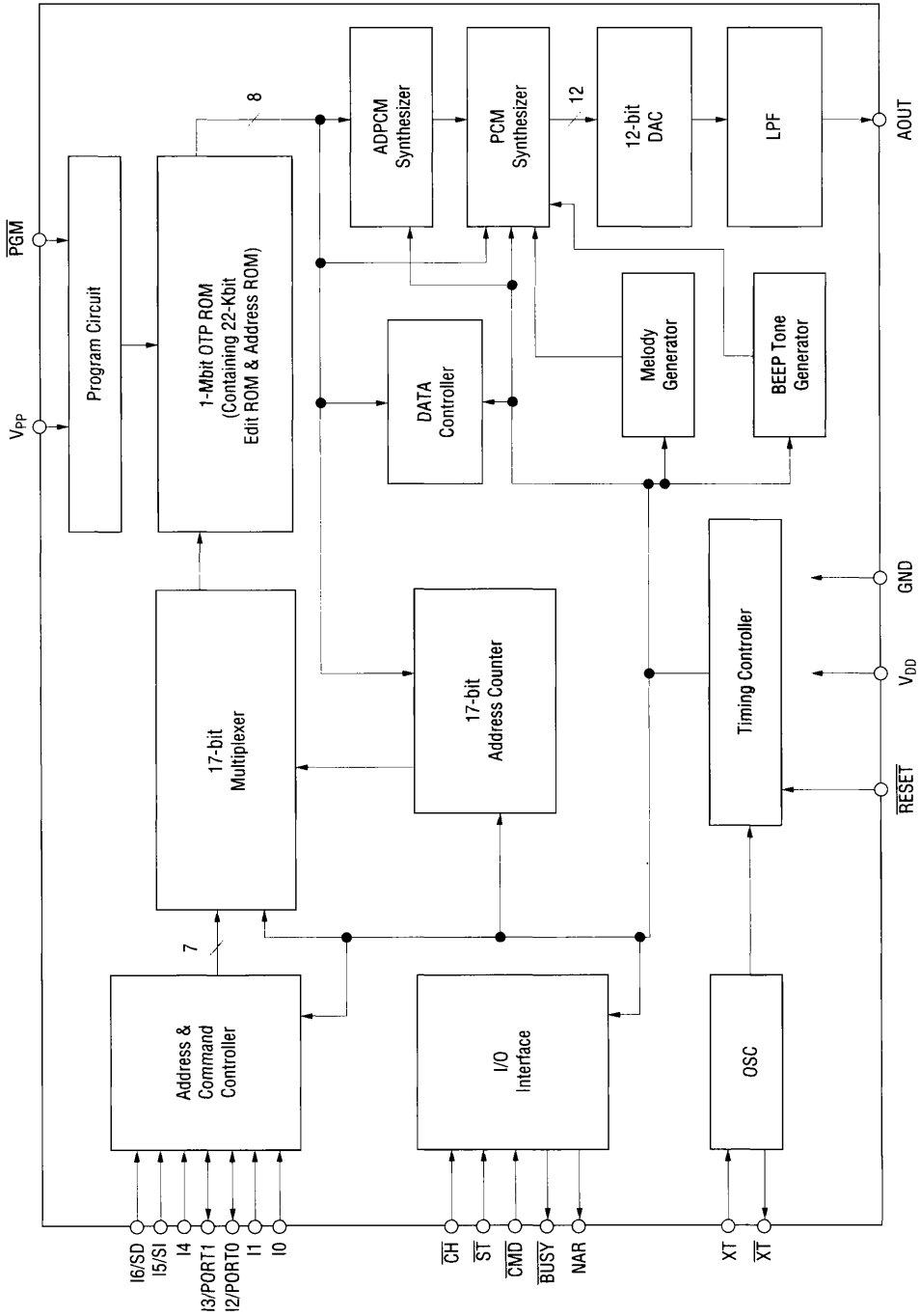

MSM6650

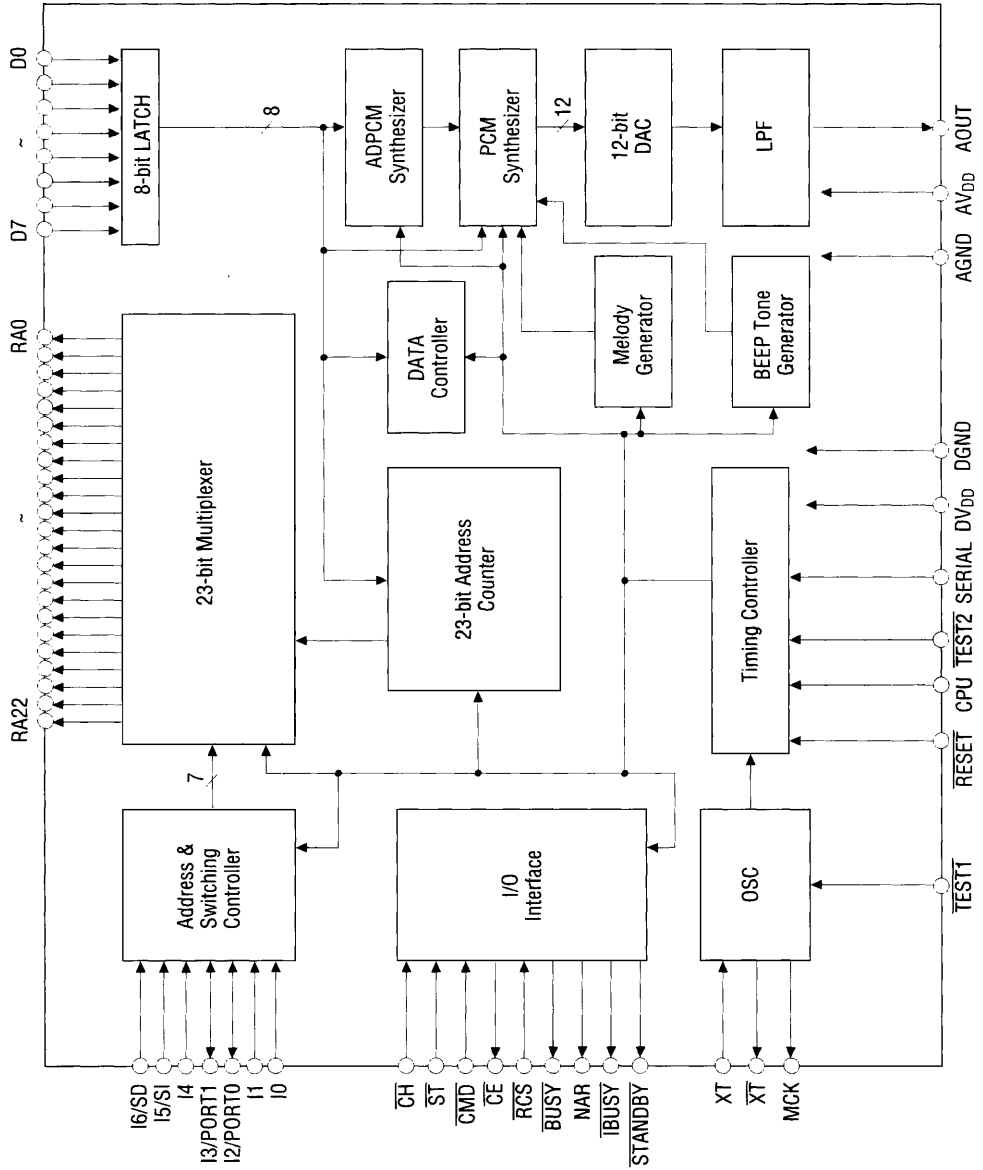

PIN CONFIGURATION (TOP VIEW)

The MSM66P54-XX has two more pins than the MSM6652-6656 while their pin configurations are identical.

The additional two pins (V_{PP} , \overline{PGM}) of the MSM66P54-XX may be open at playback after completion of writing.

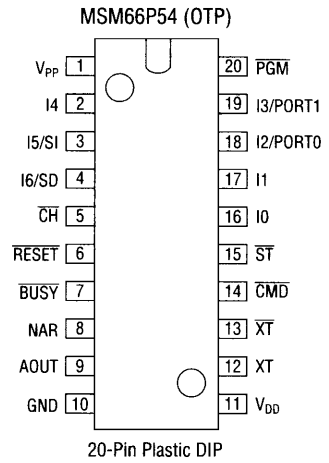
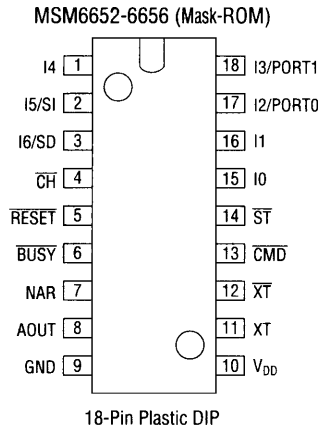

MSM6652-XXXRS, MSM6653-XXXRS, MSM6654-XXXRS,
MSM6655-XXXRS, MSM6656-XXXRS, MSM6652A-XXXRS,
MSM6653A-XXXRS, MSM6654A-XXXRS,
MSM6655A-XXXRS, MSM6656A-XXXRS

MSM66P54-01/-02RS

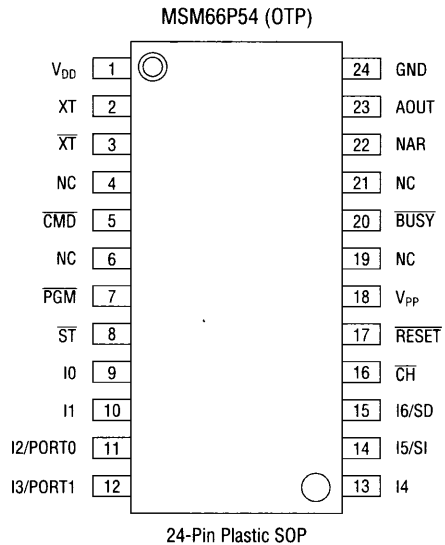
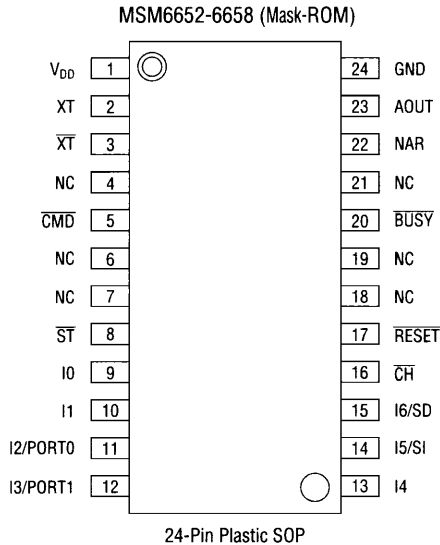

MSM6652-XXXGS-VK, MSM6653-XXXGS-VK
MSM6654-XXXGS-VK, MSM6655-XXXGS-VK,
MSM6656-XXXGS-VK, MSM6652A-XXXGS-VK,
MSM6653A-XXXGS-VK, MSM6654A-XXXGS-VK,
MSM6655A-XXXGS-VK, MSM6656A-XXXGS-VK,
MSM6658A-XXXGS-VK

MSM66P54-01/-02GS-VK

MSM6650

Product name: MSM6650GS-BK

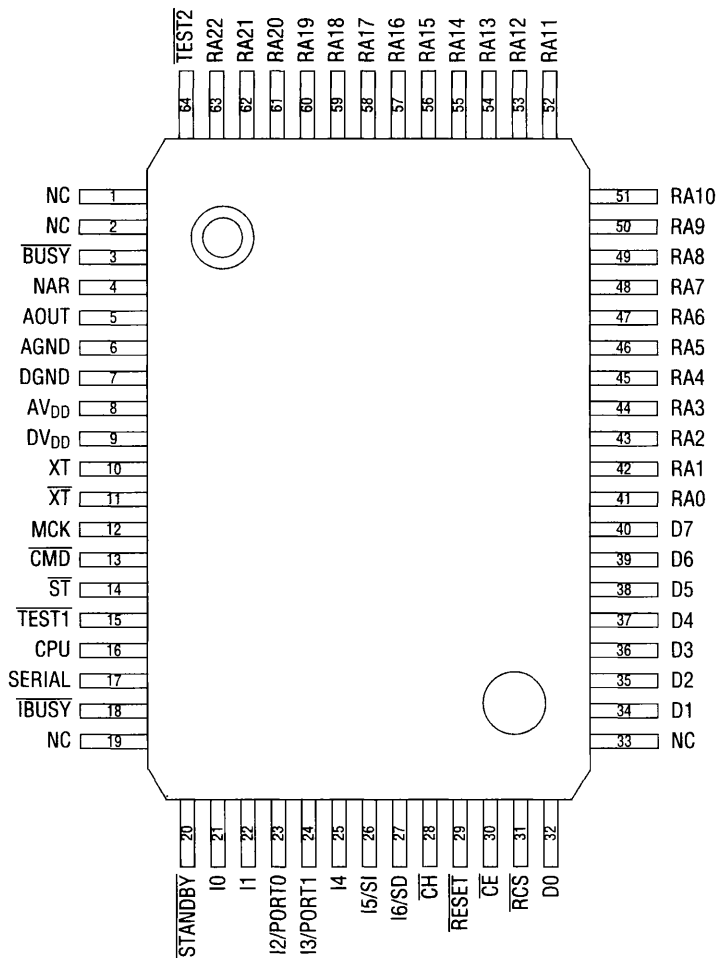

64-Pin Plastic QFP

PIN DESCRIPTIONS

Common pins for MSM6652/53/54/55/56-XXX, MSM6652A/53A/54A/55A/56A/58A-XXX, MSM66P54-XX, MSM6650

Symbol	Type	Description
$\overline{\text{RESET}}$	I	Reset. The devices enter standby status when a low level is input to this pin. When RESET, oscillation stops. The AOUT output goes to ground and the IC status is reinitialized. The devices have an internal power-on reset. V_{DD} must be raised within 1 ms to operate power-on reset correctly. If V_{DD} is not raised within 1 ms, then the $\overline{\text{RESET}}$ pulse must be applied when power is turned ON. This pin has an internal pull-up resistor.
$\overline{\text{BUSY}}$	O	Busy. Outputs a "L" level during playback and a "H" level when power is turned ON.
NAR	O	The CMD and ST inputs become effective when high. NAR indicates whether the address bus (I0 through I6) is ready to accept another address. When high, it is ready to accept. NAR goes high when power is turned ON.
AOUT	O	Analog Speech Output. D/A converter output or LPF output is selected by entering the command.
XT	I	Ceramic Oscillator Input. This pin has an internal 0.5 to 5 M Ω feedback resistor between XT and $\overline{\text{XT}}$. If an external clock is used, this is the clock input pin.
$\overline{\text{XT}}$	O	Ceramic Oscillator Output. If an external clock is used, leave this pin open.
$\overline{\text{CMD}}$	I	Command Input and Option Control. This pin is used as command and option input when CMD is at the high level with $\overline{\text{ST}}$ low. If this pin is not used or serial input is optioned, set this pin to "H" level. This pin has an internal pull-up resistor.
$\overline{\text{ST}}$	I	Start. Speech playback starts at the fall of the $\overline{\text{ST}}$ pulse. The I0 - I6 addresses are latched at the rise of the $\overline{\text{ST}}$ pulse. Input a $\overline{\text{ST}}$ pulse when NAR goes to the high level for channels 1 and 2. This pin has an internal pull-up resistor.
$\overline{\text{CH}}$	I	Channel Control. Channel 1 is selected when the input is pulled high. Channel 2 is selected when the input is low. This pin has an internal pull-up resistor.
I6/SD	I	This pin is command and user-defined phrase input when parallel input is optioned. This pin is serial data (command and address) input when serial input is optioned.
I5/SI	I	This pin is command and user-defined phrase input when parallel input is optioned. This pin is used as serial clock input when serial input is optioned.
I4	I	This pin is command and user-defined phrase input when parallel input is optioned. When serial input is optioned, set this pin to "L" level. This pin has an internal pull-down resistor.
I3/PORT1	I/O	This pin is command and user-defined phrase input when parallel input is optioned. When serial input is optioned, this pin is a port output. The port output is controlled by entering external silence insertion code.
I2/PORT0	I/O	This pin is command and user-defined phrase input when parallel input is optioned. When serial input is optioned, this pin is a port output. The port output is controlled by entering external silence insertion code.
I1, I0	I	This pin is command and user-defined phrase input when parallel input is optioned. When serial input is optioned, set this pin to "L" level. This pin has an internal pull-down resistor.

Common pins for MSM6652/53/54/55/56-XXX, MSM6652A/53A/54A/55A/56A/58A-XXX, MSM66P54-XX

Symbol	Type	Description
GND	—	Ground pin.
V _{DD}	—	Power supply. Insert a 0.1 μF or more bypass capacitor between this pin and GND.

Pins for MSM66P54-XX

Symbol	Type	Description
V _{pp}	—	Supply voltage for writing data to internal OTP ROM.
$\overline{\text{PGM}}$	I	Interface with voice analysis edit tools AR761 and AR762. Set to "L" level or leave open during playback. This pin has an internal pull-down resistor.

Pins for MSM6650

Symbol	Type	Description
AGND	—	Analog ground pin.
DGND	—	Digital ground pin.
AV _{DD}	—	Analog power pin.
DV _{DD}	—	Digital power pin.
MCK	O	Main clock output pin. Use MCK as a connection pin for the MSC1192, etc. When the IC is in standby status, MCK is held high.
CPU	I	CPU Mode. Set to "H" level to select Microcontroller Interface Mode.
SERIAL	I	Serial/Parallel Interface Select. This input selects either the parallel or the serial input interface. The serial input interface is selected with a high level; the parallel input interface is selected with a low level.
$\overline{\text{CE}}$	O	Chip Enable. $\overline{\text{CE}}$ is a timing output pin to control read of external memory. This pin outputs when $\overline{\text{RCS}}$ is at the "L" level. This pin goes high impedance when $\overline{\text{RCS}}$ is at the "H" level.
$\overline{\text{RCS}}$	I	Read Chip Select. The data bits D0-D7 are internally pulled down when $\overline{\text{RCS}}$ is high.
D7 - D0	I	External Memory Data Bus. Data is input when RCS is low. When RCS is high, these pins become low due to internal pull-down resistors.
RA22 - RA0	O	External Memory Address. These are address pins for an external memory output when $\overline{\text{RCS}}$ is low. These pins become high impedance status if $\overline{\text{RCS}}$ is in "H" level.
$\overline{\text{TEST}}1, 2$	I	Test. Set these pins to "H" level.
$\overline{\text{IBUSY}}$	O	Outputs a "L" level during playback or when AOUT is at 1/2 V _{DD} (except standby conversion)
STANDBY	O	Outputs a "L" level during which the device is oscillating.

ABSOLUTE MAXIMUM RATINGS

(GND=0 V)

Parameter	Symbol	Condition	Rating	Unit
Power supply voltage	V_{DD}	$T_a = 25^\circ\text{C}$	-0.3 to +7.0	V
Input voltage	V_{IN}		-0.3 to $V_{DD}+0.3$	V
Storage temperature	T_{STG}	—	-55 to +150	$^\circ\text{C}$

RECOMMENDED OPERATING CONDITIONS

(GND=0 V)

Parameter	Symbol	Condition	Range			Unit
Power supply voltage	V_{DD}	MSM6652-56, MSM6650, MSM6652A-56A	+2.7 to +5.5			V
		MSM6658A, MSM66P54	+2.4 to +5.5			V
Operating temperature	T_{op}	—	-40 to +85			$^\circ\text{C}$
Master clock frequency	f_{osc}	—	Min.	Typ.	Max.	MHz
			3.5	4.096	4.5	

ELECTRICAL CHARACTERISTICS

DC Characteristics

(V_{DD}=5.0 V, GND=0 V, T_a=-40 to +85°C)

Parameter	Symbol	Condition	Min.	Typ.	Max.	Unit
High level input voltage	V _{IH}	—	4.2	—	—	V
Low level input voltage	V _{IL}	—	—	—	0.8	V
High level output voltage	V _{OH}	I _{OH} =-1 mA	4.6	—	—	V
Low level output voltage	V _{OL}	I _{OL} =2 mA	—	—	0.4	V
High level input current 1	I _{IH1}	V _{IH} =V _{DD}	—	—	10	μA
High level input current 2	I _{IH2}	Internal pull-down resistor	30	90	200	μA
Low level input current 1	I _{IL1}	V _{IL} =GND	-10	—	—	μA
Low level input current 2 (Note1)	I _{IL2}	Internal pull-up resistor	-200	-90	-30	μA
Operating current	I _{DD}	—	—	6	10	mA
Standby current	I _{DS}	—	—	—	10	μA
D/A output relative accuracy	V _{DAE}	When D/A output selected	—	—	40	mV
D/A output impedance	R _{DAO}	When D/A output selected (Note2)	15	25	35	kΩ
		When D/A output selected (Note3)	15	30	45	kΩ
LPF driving resistance	R _{AOUT}	When LPF output selected	50	—	—	kΩ
LPF output impedance	R _{LPF}	I _F =100 μA	—	1	3	kΩ

Note 1. Applied to RESET, CMD, ST, CH.

2. Applied to MSM6652/53/54/55/56, MSM6652A/53A/54A/55A/56A/58A, MSM6650.

3. Applied to MSM66P54.

DC Characteristics

(V_{DD}=3.1 V, GND=0 V, T_a=-40 to +85°C)

Parameter	Symbol	Condition	Min.	Typ.	Max.	Unit
High level input voltage	V _{IH}	—	2.7	—	—	V
Low level input voltage	V _{IL}	—	—	—	0.5	V
High level output voltage	V _{OH}	I _{OH} =-1 mA	2.6	—	—	V
Low level output voltage	V _{OL}	I _{OL} =2 mA	—	—	0.4	V
High level input current 1	I _{IH1}	V _{IH} =V _{DD}	—	—	10	μA
High level input current 2	I _{IH2}	Internal pull-down resistor	10	30	100	μA
Low level input current 1	I _{IL1}	V _{IL} =GND	-10	—	—	μA
Low level input current 2 (Note)	I _{IL2}	Internal pull-up resistor	-100	-30	-10	μA
Operating current	I _{DD}	—	—	4	7	mA
Standby current	I _{DS}	—	—	—	1	μA
D/A output relative accuracy	V _{DAE}	When D/A output selected	—	—	20	mV
D/A output impedance	R _{DAO}	When D/A output selected	15	25	35	kΩ
LPF driving resistance	R _{AOUT}	When LPF output selected	50	—	—	kΩ
LPF output impedance	R _{LPF}	I _F =100 μA	—	1	3	kΩ

Note: Applied to RESET, CMD, ST, CH. Not applied to MSM66P54-XX.

AC Characteristics

(V_{DD}=5.0 V, GND=0 V, T_a=-40 to +85°C)

Parameter	Symbol	Condition	Min.	Typ.	Max.	Unit
Master clock duty cycle	f _{duty}	—	40	50	60	%
RESET input pulse width	t _{w(RST)}	—	10	—	—	μs
RESET input time after power-on	t _{D(RST)}	—	0	—	—	μs
\overline{ST} input pulse width	t _{D(\overline{ST})}	When using parallel input	0.35	—	2000	μs
\overline{ST} - \overline{ST} pulse interval	t _{SS}	When the STOP code is input	40	—	—	μs
Data setup time	t _{DW}	—	1	—	—	μs
Data hold time	t _{WD}	—	1	—	—	μs
Command setup time 1	t _{CSF}	At power-on	1	—	—	μs
Command setup time 2	t _{CS}	—	1	—	—	μs
Command hold time	t _{SC}	—	1	—	—	μs
Channel setup time	t _{CHS}	—	1	—	—	μs
Channel hold time	t _{SCH}	—	1	—	—	μs
Serial clock pulse width	t _{w(SCK)}	When using serial input	0.35	—	—	μs
Serial clock setup time	t _{SIS}	—	1	—	—	μs
Serial clock hold time	t _{SSI}	—	1	—	—	μs
Serial data setup time	t _{SDS}	When using serial input	1	—	—	μs
Serial data hold time	t _{SSD}	When using serial input	1	—	—	μs
BUSY output time 1	t _{SBS}	—	—	—	10	μs
BUSY output time 2	t _{BN}	When f _S =8 kHz	350	375	400	μs
NAR output time 1	t _{SNS}	—	—	—	10	μs
NAR output time 2	t _{NAA}	When f _S =8 kHz	350	375	400	μs
NAR output time 3	t _{NAB}	When f _S =8 kHz	350	375	400	μs
NAR output time 4	t _{NAC}	When f _S =8 kHz	350	375	500	μs
D/A converter change time	t _{DAR} , t _{DAF}	—	60	64	68	ms
LPF stable time	t _L	—	6	8	10	ms
Standby conversion time (after voice ends)	t _{STB}	—	0.15	0.2	0.25	sec

TIMING DIAGRAMS

Power-On Timing

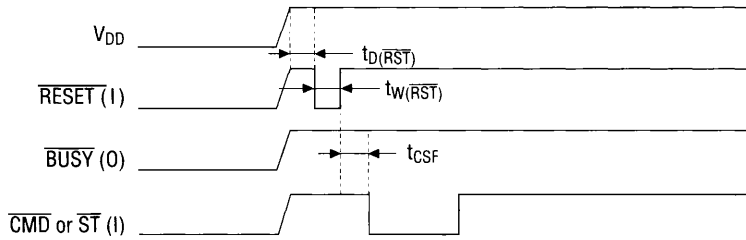

Activation of Standby State Timing

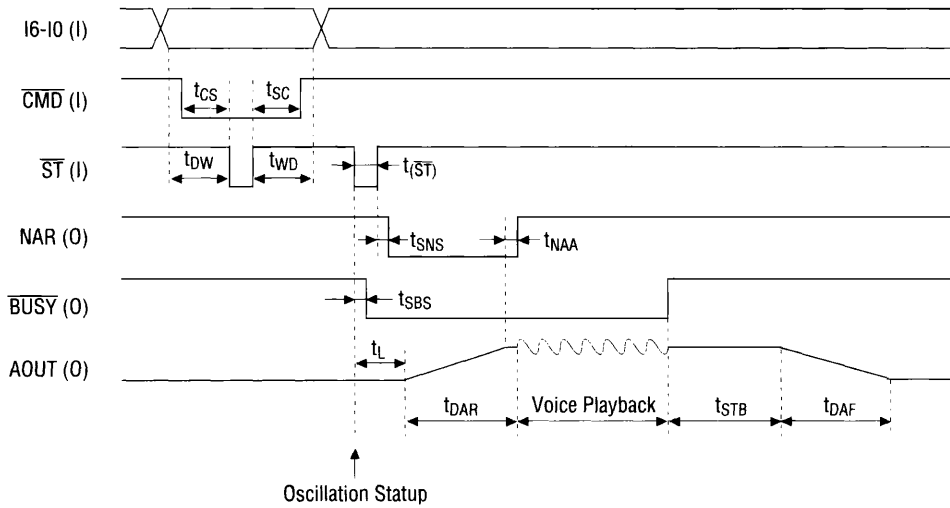

Channel 1 Playback Timing with No External Commands (Parallel Input)

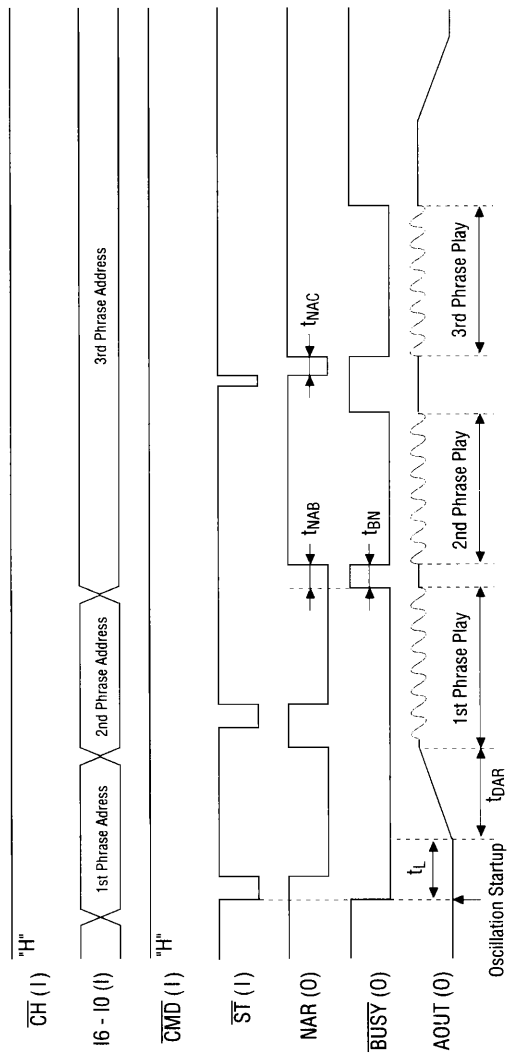

Channel 1 Playback Timing when External Commands are Used (Parallel Input)

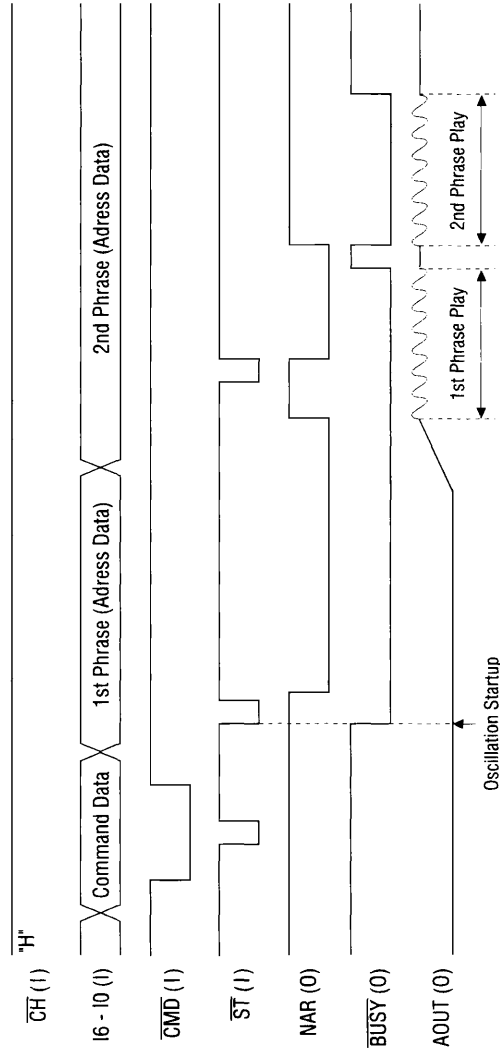

Playback timing set by entering an external command remains unchanged unless other external command is entered. Therefore, both 1st phrase and 2nd phrase are played in the same timing. To change playback timing, be sure to enter command data before address data.

Channels 1 and 2 Playback Timing when External Commands are Used (Parallel Input)

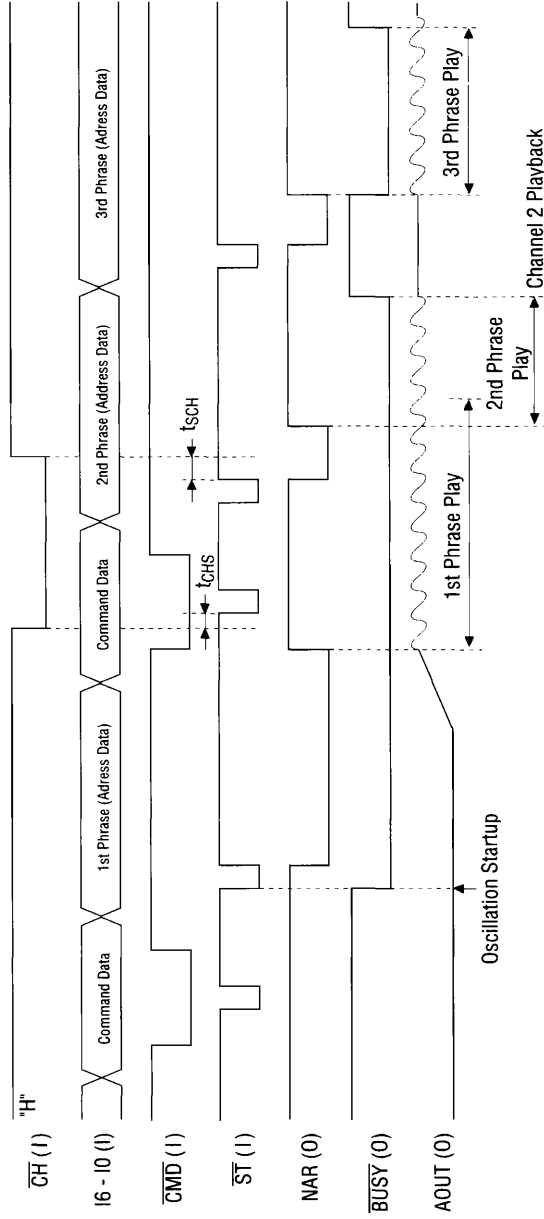

Command data keeps a just previous command regardless of the channel. If playback starts without setting of command, the 3rd phrase is played as set in the 2nd phrase.

Playback Timing with No External Commands (Serial Input)

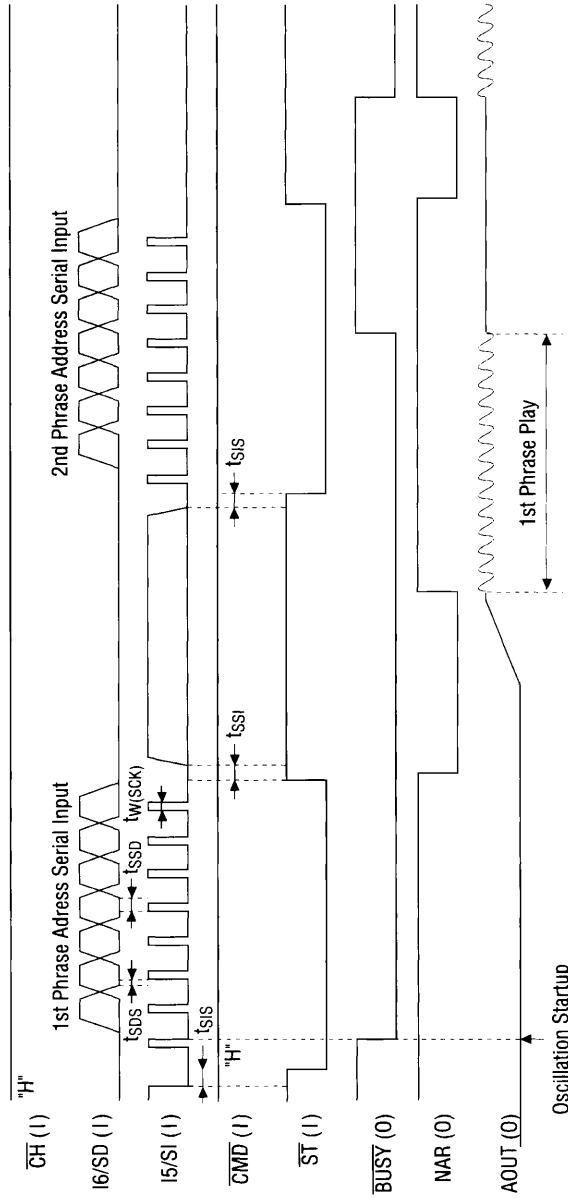

When serial input is selected, data is transferred into the IC when the \overline{ST} signal is triggered after serial data is entered. SD is captured on the leading edge of SI .

Note : Set $I5/SI$ to "L" level before \overline{ST} falls to "L" level.

Playback Timing with External Commands (Serial Input)

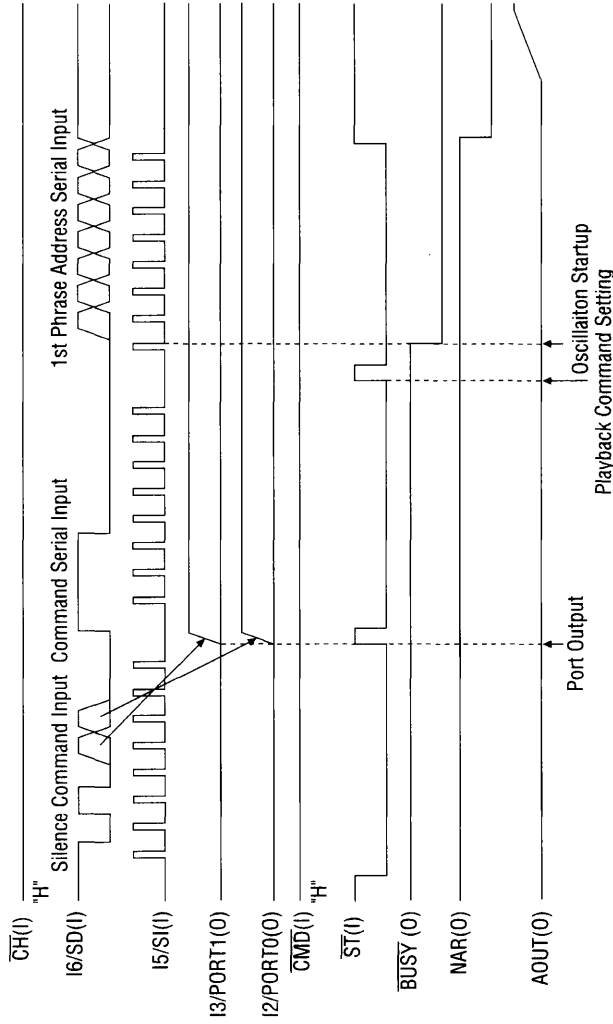

Serial input enables setting a port output by entering a command. Since port output commands and internal commands are shared, if a command for port output is entered, address data should be entered after a command for voice is entered. Otherwise, the input is recognized as a silence insertion code by the IC.

The number of command inputs are not limited until address input. However, an effective command is the one finally entered (common for channel 1 and channel 2).

FUNCTIONAL DESCRIPTION

Parallel or serial input can be selected for the microcontroller interface. Table 1.1 shows the correspondence, between serial input and parallel input.

Table 1.1 Interface

	Pin name	Serial input	Parallel input
MSM6652/53/54/55/56, MSM6652A/53A/54A/55A/56A/58A	—	Mask option	
MSM66P54	—	-01 code	-02 code
MSM6650	CPU	"H"	"H"
	SERIAL	"H"	"L"

1. PLAYBACK CODE SPECIFICATION

The user can specify a maximum of 127 phrases. Table 1.1 shows the settings by I6 to I0.

Table 1.2 User Specified Phrase List

I6-I0	Code Details
0000000	Stop Code
0000001 s 1111111	User Specified Phrase (127 Phrases)

2. INTERNAL ROM USAGE AND DISABLED AREA

(MSM6652/53/54/55/56-XXX, MSM6652A/53A/54A/55A/56A/58A-XXX, MSM66P54-XX)

The last 3 bytes of the internal ROM are not to be used as shown in Table 2.1. Please do not use these when creating the sound ROM.

Table 2.1 shows the addresses that are disabled.

Table 2.1 Internal ROM Layout and Disabled Area

Type	Voice Data Area	Disabled Area
MSM6652, 6652A	00B00-08FFC	08FFD, 08FFE, 08FFF
MSM6653, 6653A	00B00-10FFC	10FFD, 10FFE, 10FFF
MSM6654, 6654A	00B00-1FFFC	1FFFD, 1FFFE, 1FFFF
MSM6655, 6655A	00B00-2FFFC	2FFFD, 2FFFE, 2FFFF
MSM6656, 6656A	00B00-3FFFC	3FFFD, 3FFFE, 3FFFF
MSM6658A	00B00-7FFFC	7FFFD, 7FFFE, 7FFFF
MSM66P54	00B00-1FFFC	1FFFD, 1FFFE, 1FFFF

Note: Addresses are in hex.

3. PULL-UP/PULL-DOWN RESISTOR

RESET, CMD, ST and CH pins have internal pull-up resistor. I6 to I0 pins do not have internal pull-up/pull-down resistor.

When serial input option is selected, I4, I1 and I0 pins have internal pull-down resistor.

Table 3.1 Pins with Pull-up/Pull-down resistor

	Serial input		Parallel input	
	Pull-up resistor	Pull-down resistor	Pull-up resistor	Pull-down resistor
MSM6652/53/54/55/56, MSM6652A/53A/54A/ 55A/56A/58A	RESET,CMD,ST,CH	I4, I1, I0	RESET,CMD,ST,CH	—
MSM66P54	RESET,CMD,ST,CH	I4, I1, I0	RESET,CMD,ST,CH	—
MSM6650	RESET,CMD,ST,CH	I4, I1, I0	RESET,CMD,ST,CH	—

4. OPTIONS

In microcontroller interface mode, two option selection methods are available; i.e. the mask option to be set at the time of manufacture of ROM data and the command option which is set by the command setting.

In the mask option, either parallel input or serial input of commands and phrase addresses can be selected. However, when the mask option is selected, no change can be made once the option is selected after manufacture of ROM data.

The command option can select three items. Table 4.1 shows selectable options.

Table 4.1 Option Item List

No.	Item	Selection		Remarks
		Yes	No	
1	Standby Conversion	Yes	No	If standby conversion is selected (Yes), the MSM665X enters standby unless the next specified phrase is input within 200 ms after voice ends.
2	AOUT Output	LPF Output	DAC Output	
3	Maximum amplitude of a single phrase	0 to V_{DD}	$1/4V_{DD}$ to $3/4V_{DD}$ (1/2 amplitude)	Maximum amplitude of a single phrase

An option is set as in Table 4.2 when power is turned ON.

Table 4.2 Option Selection when Power is Turned ON

Standby Conversion	AOUT Output	Amplitude for 1 Phrase
Yes	LPF Output	0 to V_{DD}

To change an option that is already set, use the command input. If the $\overline{\text{RESET}}$ pin is set to "L" level, the option returns to the status when power was turned ON (Table 4.2).

After setting the option, be certain to input the voice, silence and BEEP tone commands, then start up.

Figures 4.1 and 4.2 show the option set timing, and Tables 4.3 and 4.4 show the corresponding options.

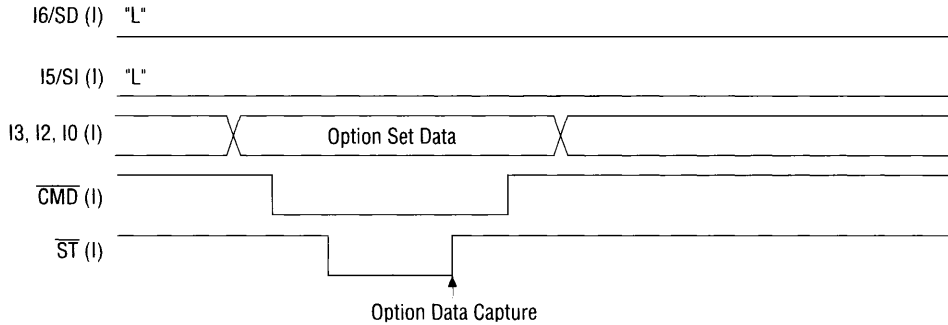

Figure 4.1 Option Set Timing (during Parallel Input)

Table 4.3 Relationship Between Options and I3, I2, I0

	I3	I2	I0
	AOUT	Standby Conversion	Amplitude of a Single Phrase
"0" Data	LPF	Yes	0 to V_{DD}
"1" Data	DAC	No	$1/4 V_{DD}$ to $3/4V_{DD}$

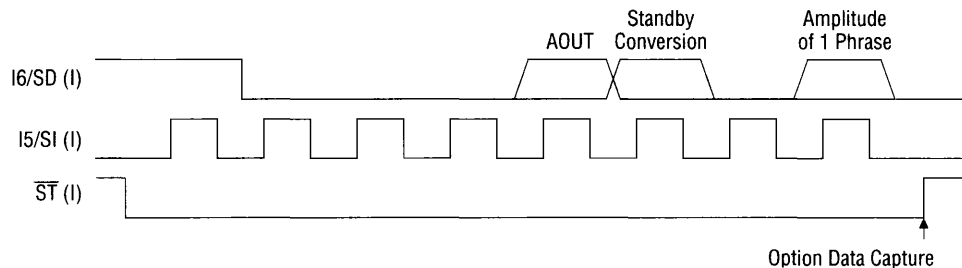

Figure 4.2 Option Set Timing (during Serial Input)

Table 4.4 Relationship Between Options and Serial Data

	AOUT	Standby Conversion	Amplitude of a Single Phrase
"0" Data	LPF	YES	0 to V_{DD}
"1" Data	DAC	NO	$1/4V_{DD}$ to $3/4V_{DD}$

5. MICROCONTROLLER INTERFACE MODE

External command settings are enabled with the microcontroller interface. However, if the edit ROM is used, the command settings of channel 1 are disabled.

Figures 5.1 and 5.2 show the command input and address input method when using the microcontroller interface.

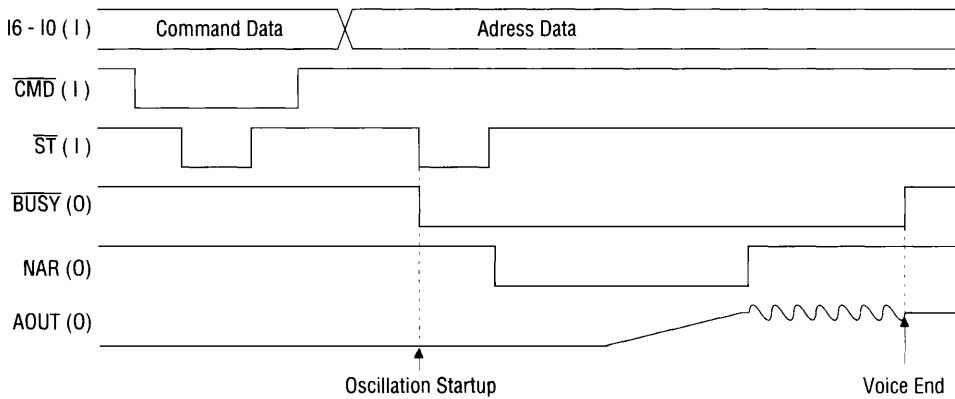

Figure 5.1 Command, Address Input Timing (Parallel Input)

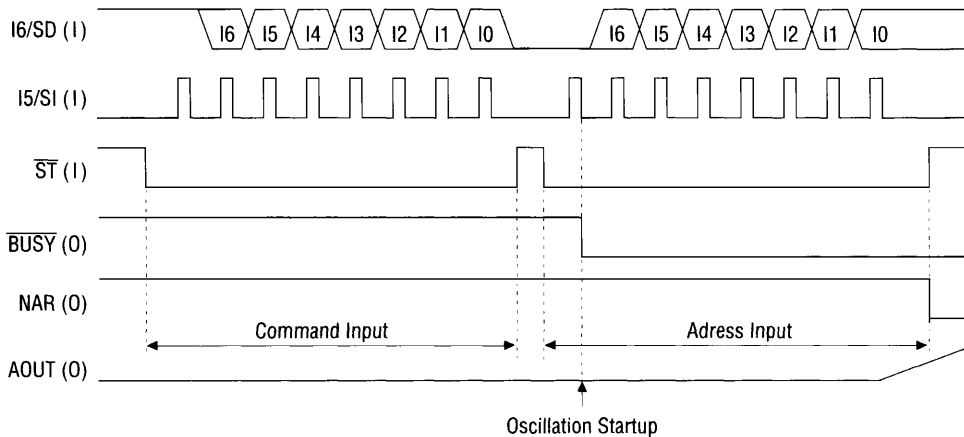

Figure 5.2 Command, Address Input Timing (Serial Input)

In microcontroller interface serial input, command and address data are identified by the initial data input serially. If the initial data is "H" level, it is identified as command data, if "L", it is identified as address data.

Command and address data must be input after the command and address identification data are input initially. Figures 5.3, 5.4 and 5.5 show the external input flow.

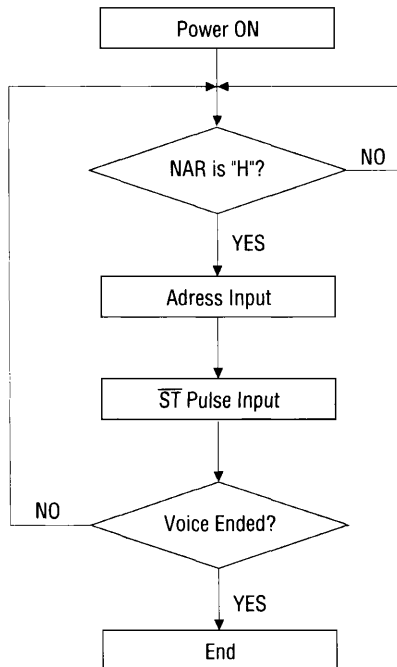

Figure 5.3 Input Flowchart when Command is Not Set

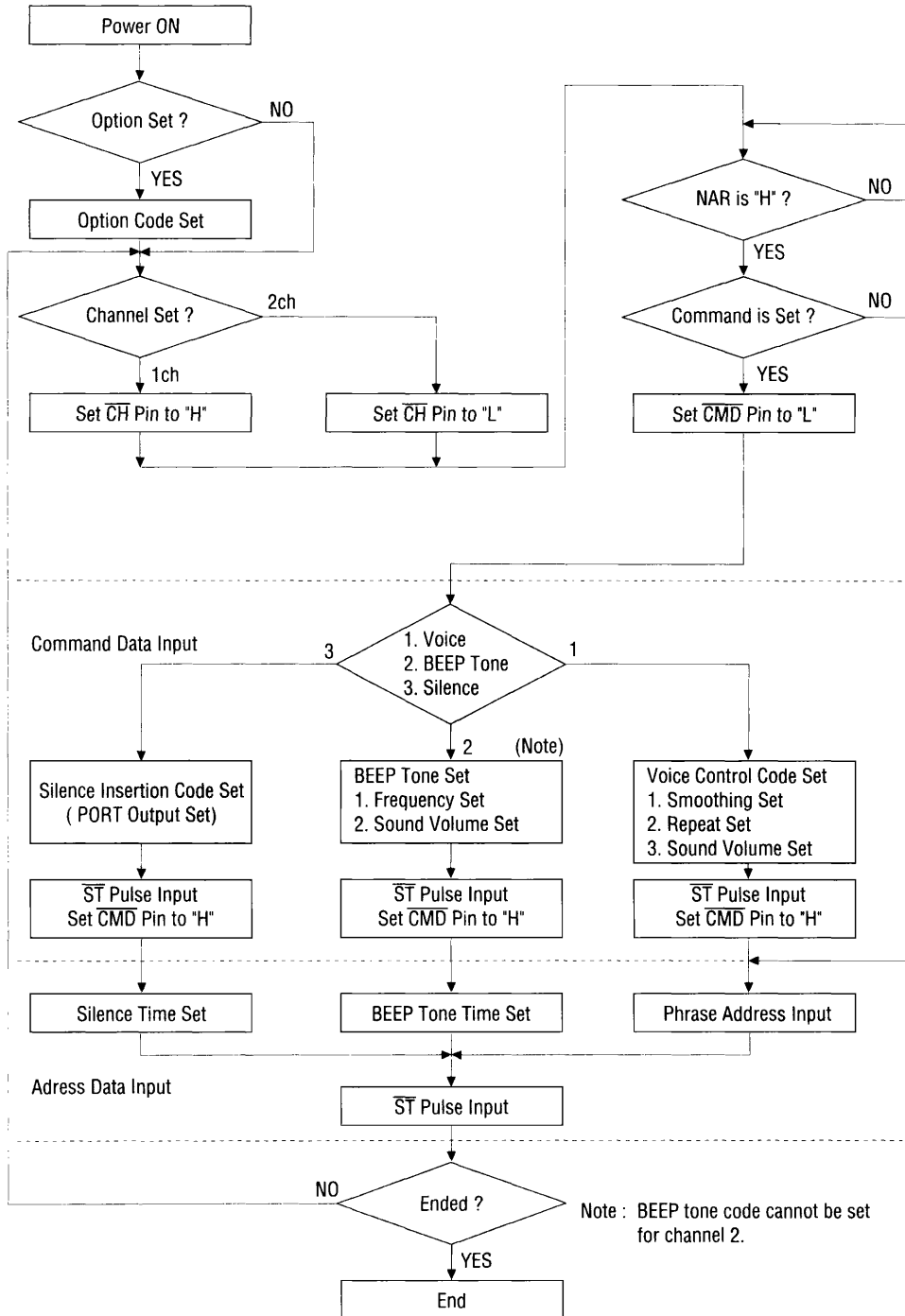

Figure 5.4 Parallel Input Flowchart when External Command is Used

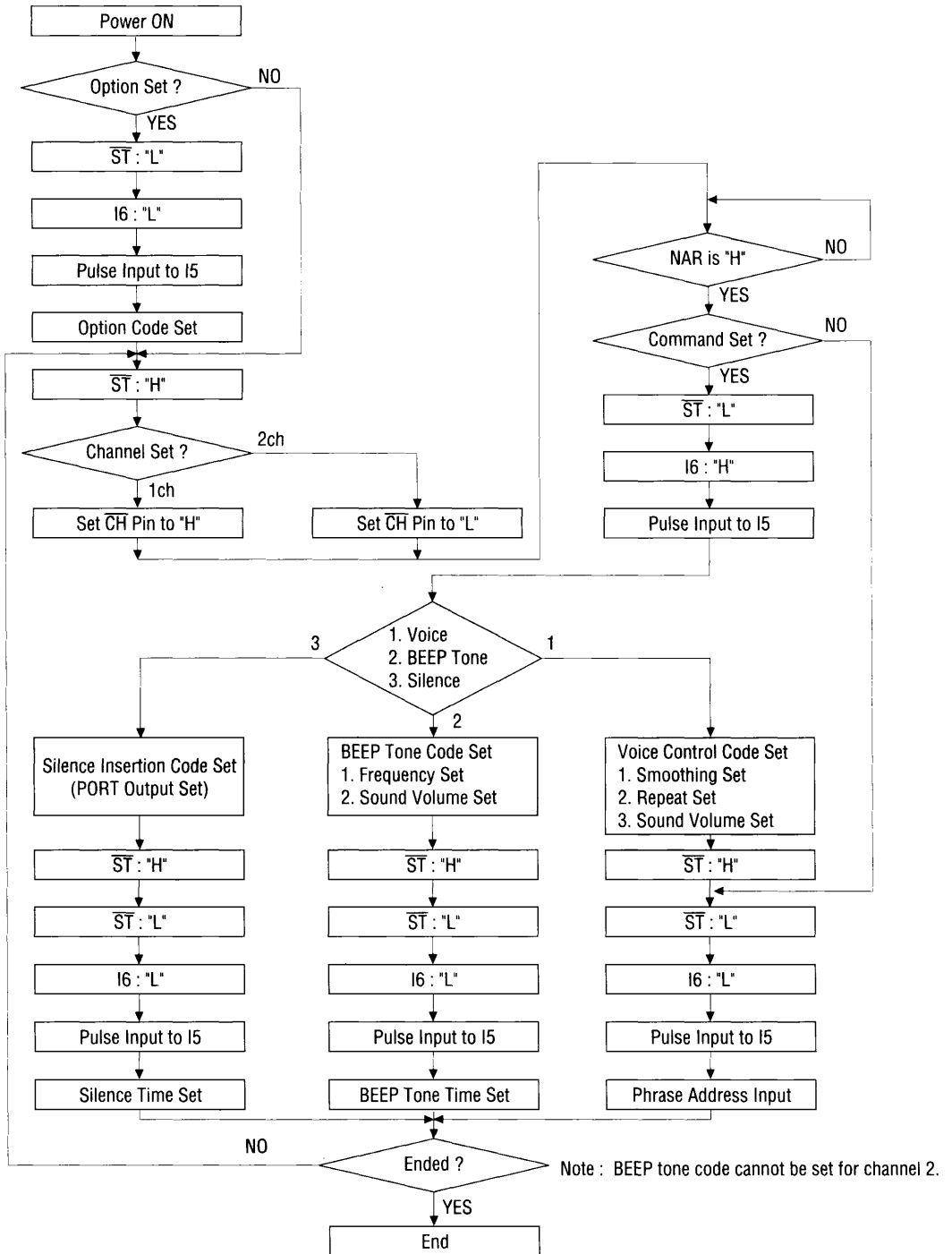

Figure 5.5 Serial Input Flowchart when External Command is Used

6. COMMAND DATA

Table 6.1 shows the conditions that can be set by the command data. Command data is set with I6-I0. In serial input, data is input corresponding to I6-I0 serially as shown in Figure 5.2.

Table 6.1 Command Setting Content List

I6	I5	I4	I3	I2	I1	I0	Command Content
0	0	0	oa	os	0	ov	Option Setting
0	1	0	p1	p0	0	0	Silence Insertion Code
1	0	0	bl1	bl0	bf1	bf0	BEEP Tone Code
1	1	sm	rp1	rp0	vl1	vl0	Speech Control Code

6.1 Option Code Setting

An option can be set by command after power on. Once an option is set, it remains effective until either power is shut OFF or until the $\overline{\text{RESET}}$ signal is input.

When an option is set, input speech, silence and BEEP tone commands again by command and address data input (phrase, silence time and BEEP tone time).

Table 6.2 shows the options that can be set.

Table 6.2 Relationship Between Options and I3, I2, I0

	I3	I2	I0
	AOUT Output	Standby Conversion	Amplitude of a Single Phrase
"0" Data	LPF	YES	0 to V_{DD}
"1" Data	DAC	NO	$1/4 V_{DD}$ to $3/4 V_{DD}$

See Figure 4.2 for command option set timing chart.

Options can be set anytime, but if set during playback, the output impedance and amplitude of AOUT may change.

6.2 Silence Insertion Code

Silence code inserts silence in the specified channel externally, thereby reducing voice data.

I6	I5	I4	I3	I2	I1	I0	
0	1	X	p1	p0	X	X	X: Don't care

Silence is inserted with command data, and silence time is set with address data. The \overline{CH} pin selects the channel for silence insertion (channel 1 or 2).

Silence time is set by address data (I6 to I0).

Minimum Silence Time: 16.384 ms
 Maximum Silence Time: $(128 - 1) \times 16.384 \text{ ms} = 2.1 \text{ sec}$

Figure 6.1 shows the channel 1 silence insertion set timing.

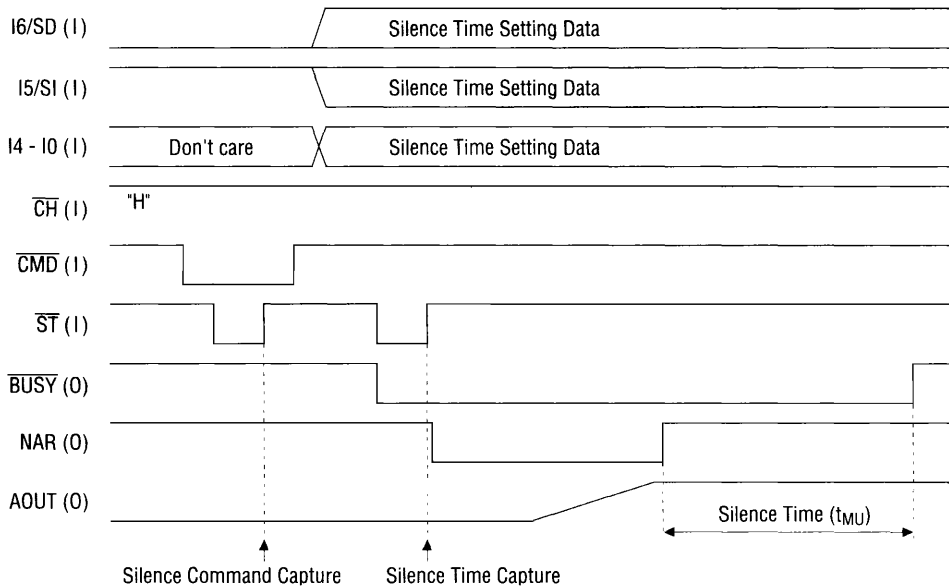

Figure 6.1 Channel 1 Silence Set Timing (Parallel Input)

For example, if silence time set data shown in Figure 6.1 is set to (I6 to I0) = ("0011000"), the silence time (t_{MU}) becomes

$$(2^6 \times 0 + 2^5 \times 0 + 2^4 \times 1 + 2^3 \times 1 + 2^2 \times 0 + 2^1 \times 0 + 2^0 \times 0) \times 16.384 \text{ ms} = 393.216 \text{ ms}$$

The formula to set silence time is shown below.

$$t_{MU} = (2^6 \times (I6) + 2^5 \times (I5) + 2^4 \times (I4) + 2^3 \times (I3) + 2^2 \times (I2) + 2^1 \times (I1) + 2^0 \times (I0)) \times 16.384 \text{ ms}$$

The channel 2 silence insertion set timing is as shown in Figure 6.2.

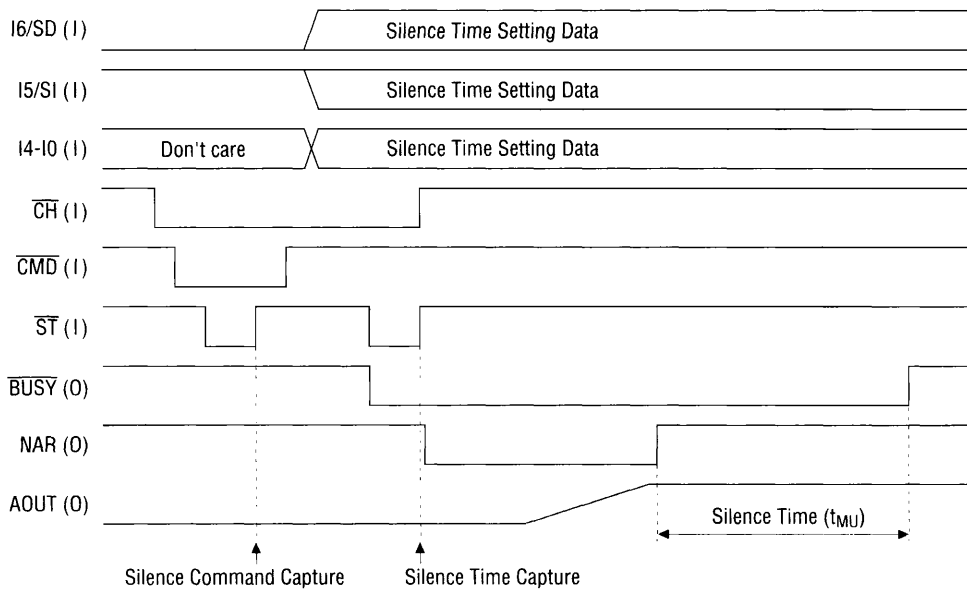

Figure 6.2 Channel 2 Silence Set Timing (Parallel Input)

In serial input, the port output signals from I3/PORT1, I2/PORT0 are also controlled by the silence insertion code. I3/PORT1, I2/PORT0 are in "L" level when power is turned ON, and when the RESET signal is input.

When setting the port outputs, first set the port output with a silence insertion code, then input a voice playback code and set the address. Figure 6.3 shows the timing.

A port cannot be set continuously, if it is necessary to set a port again (after previously being set) a BEEP tone or voice playback code must first be input, after which the port can be set again.

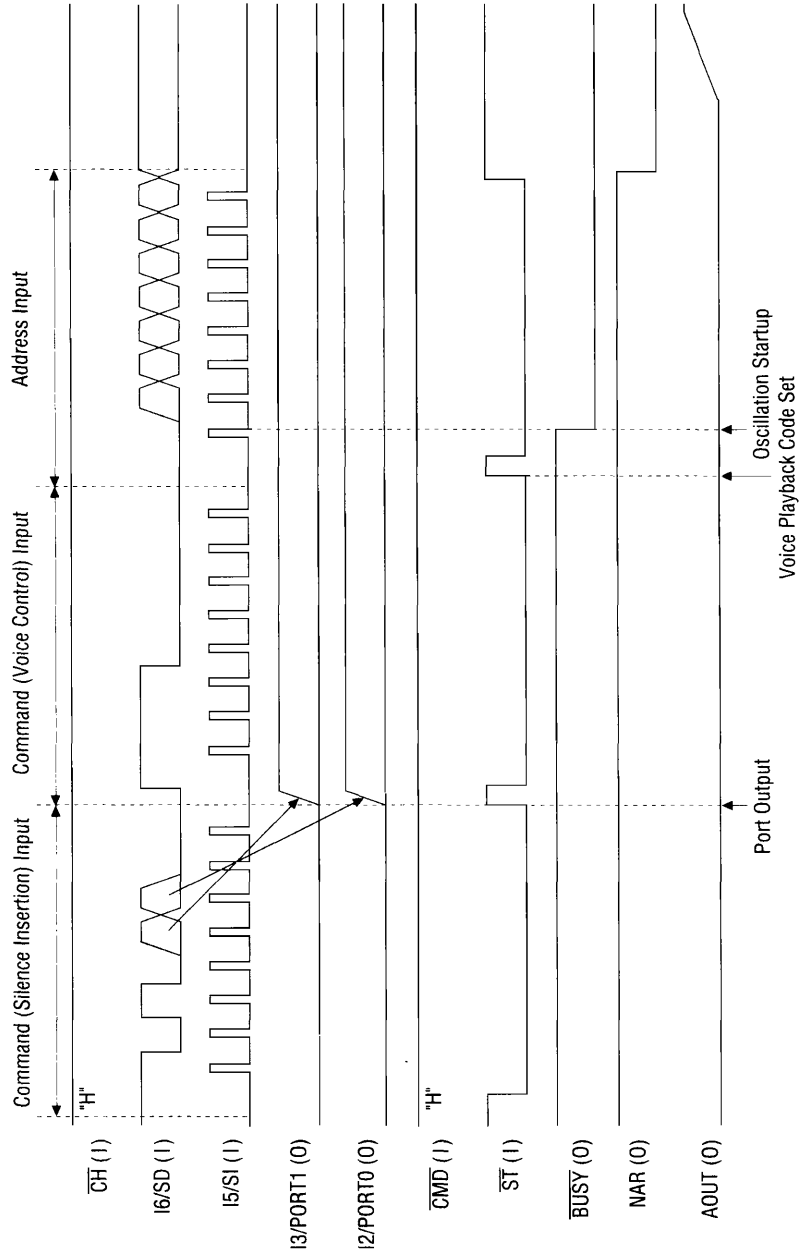

Figure 6.3 Port Output and Command, Address Set Timing (during Serial Input)

6.3 BEEP Tone Code

The BEEP tone code produces the tone from an internal circuit which is independent of the ADPCM circuitry.

A BEEP tone can be set in channel 1 only. When mixing a BEEP tone (channel 1) and an 8 kHz phrase in channel 2, be advised that playback of the phrase (at 8 kHz), also plays the BEEP tone at the phrase frequency (8 kHz).

I6	I5	I4	I3	I2	I1	I0
1	0	0	bl1	bl0	bf1	bf0

The sound volume is set with I3, I2 pins, and the frequency is set with I1, I0 pins. Tables 6.3 and 6.4 show the sound volumes and the frequencies that can be set.

Table 6.3 Sound Volume Settings

I3	I2	Sound Volume (Note 1)
0	0	1/8 amplitude sound volume of channel 1
0	1	1/4 amplitude sound volume of channel 1
1	0	1/3 amplitude sound volume of channel 1
1	1	1/2 amplitude sound volume of channel 1

Table 6.4 Frequency Settings

I1	I0	Frequency
0	0	0.5 kHz
0	1	1.0 kHz
1	0	1.3 kHz
1	1	2.0 kHz

Note 1. If 1/2 amplitude of channel 1 is set, and if the maximum amplitude is set to $1/2 V_{DD}$ as an option the sound volume of the BEEP tone becomes $1/4 V_{DD}$.

The BEEP tone time is set by address data (I6 to I0).

Minimum BEEP Tone Time: 16.384 ms
 Maximum BEEP Tone Time: $(128 - 1) \times 16.384 \text{ ms} = 2.1 \text{ sec. (approx.)}$

Figure 6.4 shows BEEP tone set timing.

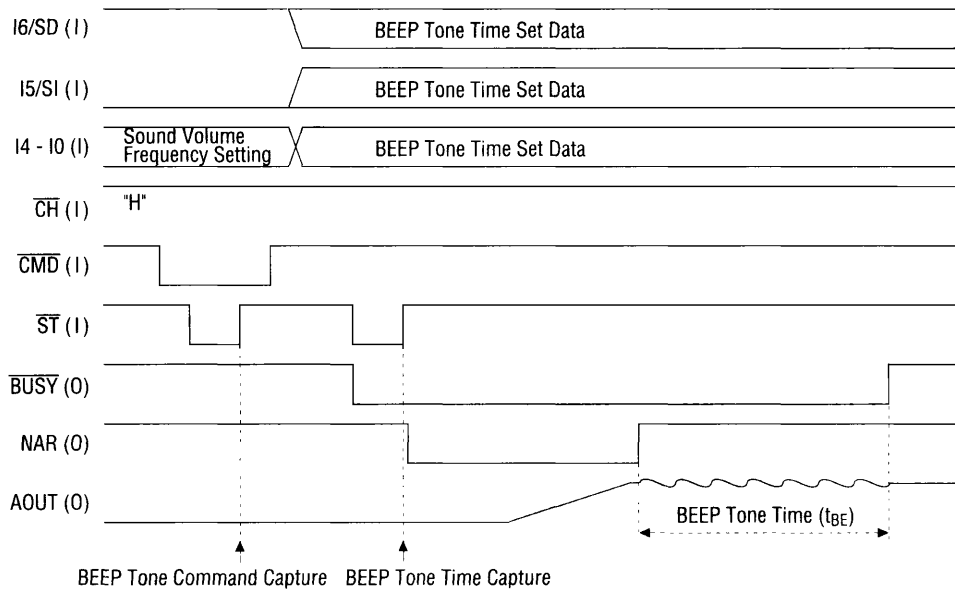

Figure 6.4 BEEP Set Timing (during Parallel Input)

For example, if the BEEP tone time set data shown in Figure 6.4 is set as (I6 to I0) = ("0011000"), the BEEP tone time (t_{BE}) is

$$(2^6 \times 0 + 2^5 \times 0 + 2^4 \times 1 + 2^3 \times 1 + 2^2 \times 0 + 2^1 \times 0 + 2^0 \times 0) \times 16.384 \text{ ms} = 393.216 \text{ ms}$$

The formula to set BEEP tone time is shown below.

$$t_{BE} = (2^6 \times (I6) + 2^5 \times (I5) + 2^4 \times (I4) + 2^3 \times (I3) + 2^2 \times (I2) + 2^1 \times (I1) + 2^0 \times (I0)) \times 16.384 \text{ ms}$$

6.4 Voice Control Code

Command data can set the number of repeats and sound volume.

I6	I5	I4	I3	I2	I1	I0
1	1	sm	rp1	rp0	vl1	vl0

Channel 1 is set when the \overline{CH} pin is "H" level, channel 2 is set when CH is "L" level. Once a command is set, it is maintained as both channels until another command is input. The condition of each channel is set by I4 to I0. Three conditions can be set: 1) to 3).

1) Setting the Number of Repeats

The number of repeats is set by the I3 and I2 pins, and four types can be selected: 1, 2, 4 and infinite. A stop code must be input to stop voice when infinite repeat is selected. Table 6.5 shows the relationship between I3 and I2 pins, and the number of repeats.

Table 6.5 Selection of Number of Repeats

I3	I2	Number of Repeats
0	0	1
0	1	2
1	0	4
1	1	Infinite

2) Sound Volume Smoothing During Repeat

If "I4" is set to a "1", sound volume during repeat is automatically attenuated from 1 to 1/2, 1/4 and 1/8 (fadeout function). This smoothing, however, is effective only when 2, 4 or infinite is selected for the repeat setting.

If infinite is selected, voice is played, remaining at 1/8 sound volume after attenuating from 1, 1/2, 1/4 and to 1/8. If the initial sound volume setting is other than 1, the sound volume attenuates from that value in 1/2 units, stopping at 1/8.

3) Setting Sound Volume

Voice volume can be changed in four steps if voice is played overlapping in channel synthesis. The sound volume is set at I1 and I0 pins.

Table 6.6 shows the relationship between I1, I0 pins and sound volume settings.

Table 6.6 Volume Attenuation Setting

I1	I0	Volume Attenuation
0	0	No attenuation (sound volume is same as voice data)
0	1	-6 dB attenuation (sound volume is 1/2 of voice data)
1	0	-12 dB attenuation (sound volume is 1/4 of voice data)
1	1	-18 dB attenuation (sound volume is 1/8 of voice data)

7. ADDRESS DATA

If a phrase is input at I6 to I0 by address data, and if \overline{ST} pulse is then applied, voice playback starts. Figure 7.1 shows voice start timing. Figure 7.2 and 7.3 show timing when an address, other than a phrase, is input.

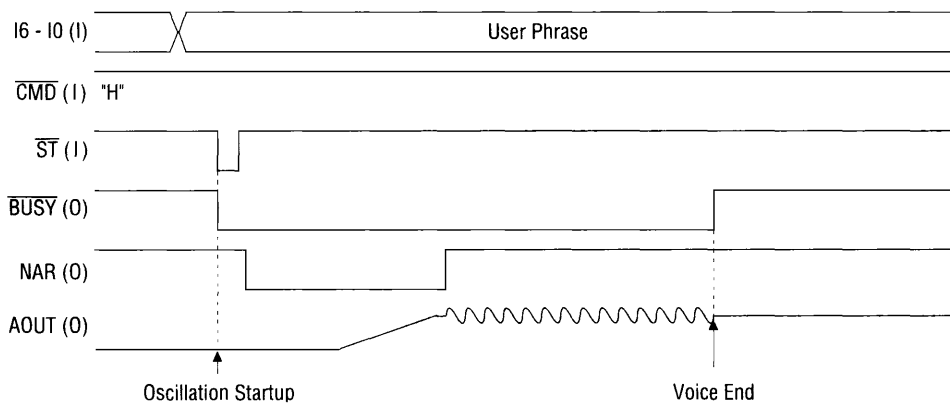
**Figure 7.1 Voice Startup Timing**

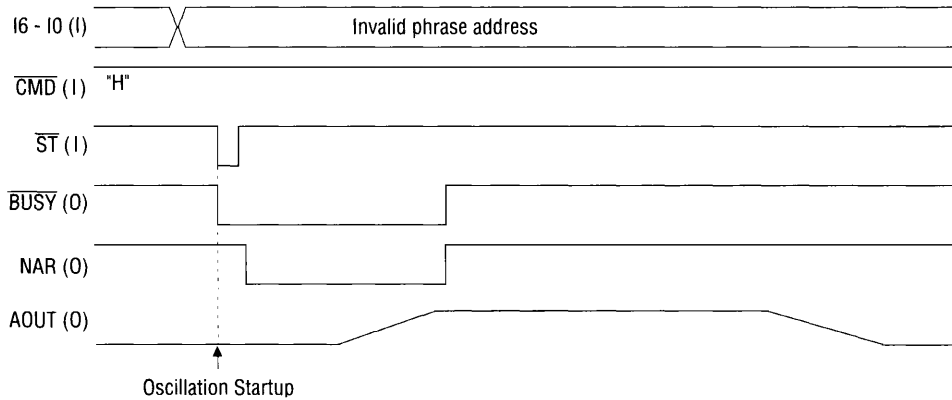

Figure 7.2 Timing when Address, Other than a Phrase, is Input in Standby Status

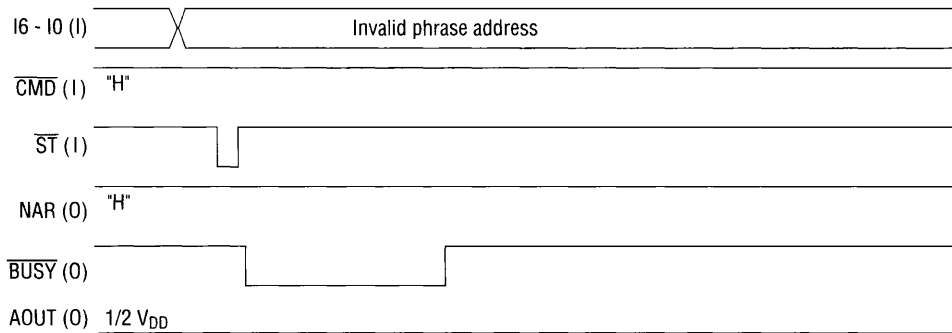

Figure 7.3 Timing when Address, Other than a Phrase, is Input when AOUT is 1/2 V_{DD}

8. STOP CODE

When I6 to I0 are set to "0000000" during voice playback and a \overline{ST} signal is input, playback stops and AOUT becomes $1/2 V_{DD}$. STOP code becomes valid at the leading edge of \overline{ST} (common with parallel and serial inputs).

Use the stop code only when the \overline{BUSY} pin is "L" level. The stop code cannot be used in states of standby-mode.

Figure 8.1 shows stop code input timing.

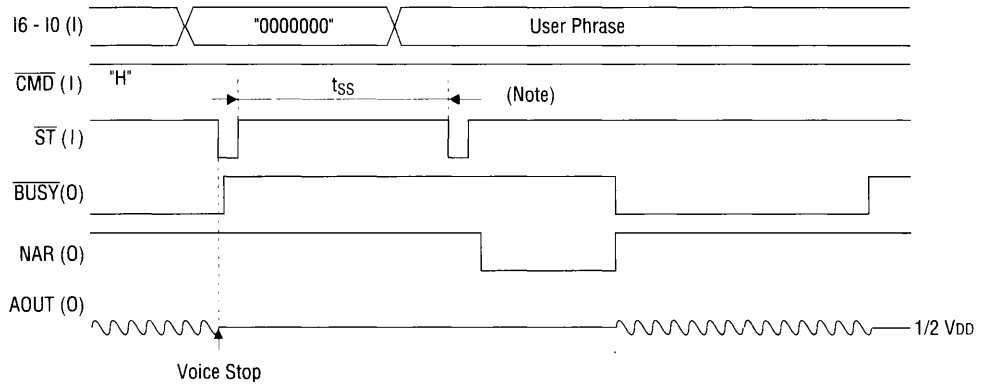

Note: t_{SS} is also applied for serial input.

The stop code is a function not to initialize the internal, but to stop a voice. In case of the initialization of the internal register, initialize the register by using the $\overline{\text{RESET}}$ pin.

9. SAMPLING FREQUENCY

Sampling frequencies can be selected for each phrase address of the internal ROM. For channel mixing, when channels 1 and 2 are played back at the same time, the channel 1 sampling frequency has priority.

The following 8 frequencies can be selected when creating voice data.

4.0 kHz, 5.3 kHz, 6.4 kHz, 8.0 kHz, 10.6 kHz, 12.8 kHz, 16.0 kHz, 32.0 kHz

10. VOICE PLAYBACK TIME

Table 10.1 shows the internal ROM configuration. The actual voice data ROM area is different from the indicated ROM capacity.

The voice data management area as shown in Table 10.1 is about 6 Kbits, and the edit ROM area includes 16 Kbits.

Table 10.1 ROM Configuration

Voice Data Management Area
Editing ROM Area
Voice Data Area
Disabled Area

Use the following formula as a guide to compute voice playback time.

$$\text{Playback Time} = (\text{ROM Capacity} - 16 - 6) \times 1024 \times 255 / 256 \div \text{Data Rate (kbps)}$$

For example, if data was created at a 4.0 kHz sampling using MSM6652 (288-Kbit internal ROM), the playback time is

$$(288 - 16 - 6) \times 1024 \times 255 / 256 \div 16 \text{ (kbps)} = 16.9 \text{ (sec.)}$$

11. CHANNEL STATUS

The $\overline{\text{BUSY}}$ and NAR pins output status signals.

$\overline{\text{BUSY}}$ pin outputs a "L" level when either channel 1 or 2 is playing. It is "H" level when power is turned ON.

The NAR pin outputs the channel 1 and 2 input status signal (Next Address Request). When this pin is at the "H" level, the $\overline{\text{ST}}$ pulse can be input. The channel status is switched by the $\overline{\text{CH}}$ pin. If the $\overline{\text{CH}}$ pin is at the "H" level, the status signal of channel 1 is output, and if $\overline{\text{CH}}$ is "L" level, the status of channel 2 is output.

12. PLAYBACK METHOD

The MSM6650 has 3 playback methods: ADPCM, PCM and melody play.

12.1 ADPCM Method

With the ADPCM (Adaptive Differential Pulse Code Modulation) method, basic quantization width Δ is adaptively changed for each sampling, and is encoded to 4-bit data.

Conversion to ADPCM data can be accomplished by the AR761 or AR762 development tool.

The ADPCM method is used for voice, music, and sound effects. It is considered the best compromise between high quality reproduction and memory usage.

12.2 PCM Method

The PCM method of the MSM6650 uses an 8-bit straight binary format. Of the three methods, PCM is the best suited for accurate reproduction of sound effects or waveforms which are pulse shaped or change rapidly (such as high frequency pure tone sinewaves).

12.3 Melody Playback Method

The development tools AR76-202 and AR203 support melody playback. The melody data can be composed by using these tools. Therefore, unique sound can be created.

12.4 Data Rate of Each Method

The data rate shows the degree of data compression and the data amount to synthesize for 1 second. The data rate is determined by the relationship between the sampling frequency and the data format (in number of bits per sample). The following formula is used.

$$\text{Data Rate (kbps)} = \text{Sampling Frequency (kHz)} \times \text{Data format (in number of bits per sample)}$$

The data rate of the three methods are compared below when the sampling frequency is 6.4 kHz.

1) ADPCM Method

$$\text{Data Rate (kbps)} = 6.4 \text{ (kHz)} \times 4 \text{ (bits)} = 25.6 \text{ (kbps)}$$

2) PCM Method

$$\text{Data Rate (kbps)} = 6.4 \text{ (kHz)} \times 8 \text{ (bits)} = 51.2 \text{ (kbps)}$$

3) Melody Playback Method

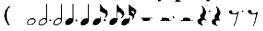
With the melody playback method, the data rate changes depend on the tempo or the kind of note () used. The formula does not determine the data rate changes. The average data rate is 8 kbps.

The data rate of the melody playback method is calculated as follows:

$$\text{Data rate} = \text{number of notes per second} \times \text{data amount per note [kbits]}$$

For example, to obtain data rate from the following conditions,

$$f_s = 6.4 \text{ kHz}$$

$$\text{Number of notes per second} = 1$$

$$\text{Time [seconds] taken for each thirty-second note} = 0.083 \text{ sec (Tempo} = 90)$$

first, obtain the data amount per note with the following expression:

$$\begin{aligned} \text{Data amount per note [kbits]} &= \text{data amount per thirty-second note [bits per note]} \times 2 \\ &\approx \text{Time taken for each thirty-second} \\ &\quad \text{note [sec]} \times f_s \text{ [Hz]} \times 8 \text{ [bits]} \times 2 \\ &= 0.083 \times 6400 \times 8 \times 2 \\ &= 8.5 \text{ [kbits]} \end{aligned}$$

Therefore, when the number of notes per second is 1, the data rate is approximately 8.5 kbps.

12.5 Channel Synthesis Combinations for Each Playback Method

Melody and BEEP tone playback is in channel 1 only.

Table 12.1 Channel Synthesis Combinations

Channel 1	Channel 2	Setting
VOICE (0 dB)	VOICE (0 dB to -18 dB)	○ Note 1
VOICE (0 dB to -18 dB)	VOICE (0 dB)	○ Note 1
VOICE (-6 dB to -18 dB)	VOICE (-6 dB to -18 dB)	○
VOICE (0 dB to -18 dB)	MELODY (0 dB to -18 dB)	×
VOICE (0 dB to -18 dB)	PCM (0 dB)	○ Note 1
VOICE (0 dB)	PCM (0 dB to -18 dB)	○ Note 1
VOICE (-6 dB to -18 dB)	PCM (-6 dB to -18 dB)	○
VOICE (0 dB to -18 dB)	BEEP TONE (1/2, 1/3, 1/4, 1/8)	×
VOICE (0 dB to -18 dB)	SILENCE	○
MELODY (0 dB)	VOICE (0 dB to -18 dB)	○ Note 1
MELODY (0 dB to -18 dB)	VOICE (0 dB)	○ Note 1
MELODY (-6 dB to -18 dB)	VOICE (-6 dB to -18 dB)	○
MELODY (0 dB to -18 dB)	MELODY (0 dB to -18 dB)	×
MELODY (0 dB)	PCM (0 dB to -18 dB)	○ Note 1
MELODY (0 dB to -18 dB)	PCM (0 dB)	○ Note 1
MELODY (-6 dB to -18 dB)	PCM (-6 dB to -18 dB)	○
MELODY (0 dB to -18 dB)	BEEP TONE (1/2, 1/3, 1/4, 1/8)	×
MELODY (0 dB to -18 dB)	SILENCE	○
PCM (0dB)	VOICE (0 dB to -18 dB)	○ Note 1
PCM (0 dB to -18 dB)	PCM (0 dB)	○ Note 1
PCM (-6 dB to -18 dB)	PCM (-6 dB to -18 dB)	○
PCM (0 dB to -18 dB)	MELODY (0 dB to -18 dB)	×
PCM (0 dB)	PCM (0 dB to -18 dB)	○ Note 1
PCM (0 dB to -18 dB)	PCM (0 dB)	○ Note 1
PCM (-6 dB to -18 dB)	PCM (-6 dB to -18 dB)	○
PCM (0 dB to -18 dB)	BEEP TONE (1/2, 1/3, 1/4, 1/8)	×
PCM (0 dB to -18 dB)	SILENCE	○
BEEP TONE (1/2, 1/3, 1/4, 1/8)	VOICE (0 dB)	○ Note 1
BEEP TONE (1/2, 1/3, 1/4, 1/8)	VOICE (-6 dB to -18 dB)	○
BEEP TONE (1/2, 1/3, 1/4, 1/8)	MELODY (0 dB to -18 dB)	×
BEEP TONE (1/2, 1/3, 1/4, 1/8)	PCM (0 dB)	○ Note 1
BEEP TONE (1/2, 1/3, 1/4, 1/8)	PCM (-6 dB to -18 dB)	○
BEEP TONE (1/2, 1/3, 1/4, 1/8)	BEEP TONE (1/2, 1/3, 1/4, 1/8)	×
BEEP TONE (1/2, 1/3, 1/4, 1/8)	SILENCE	○
SILENCE	SILENCE (0 dB to -18 dB)	○
SILENCE	MELODY (0 dB to -18 dB)	×
SILENCE	PCM (0 dB to -18 dB)	○
SILENCE	BEEP TONE (1/2, 1/3, 1/4, 1/8)	×
SILENCE	SILENCE	○

Note 1. In the case of channel synthesis, verify the voice quality with the MSM6650 evaluation board. The combination of channel 1 and 2 can sometimes cause chipping if either of the channels is recorded at a level which is too high.

13. STANDBY CONVERSION

If standby conversion YES is selected by command option, the IC enters standby status and stops all operations if the next phrase does not start up within 0.2 sec after playback ends. If restarted it takes about 100 ms until voice starts, since a pop noise countermeasure circuit operates.

If standby conversion NO is selected by command option, the IC does not enter standby status, even if voice ends, and the output of AOUT becomes about $1/2 V_{DD}$. Current is flowing since oscillation is operating. If started up voice starts in about 350 ms.

If standby conversion NO is selected, it is necessary to input a $\overline{\text{RESET}}$ pulse to enter stanby status.

If a $\overline{\text{RESET}}$ pulse is input, a pop noise is generated since the AOUT output level instantaneously becomes GND level.

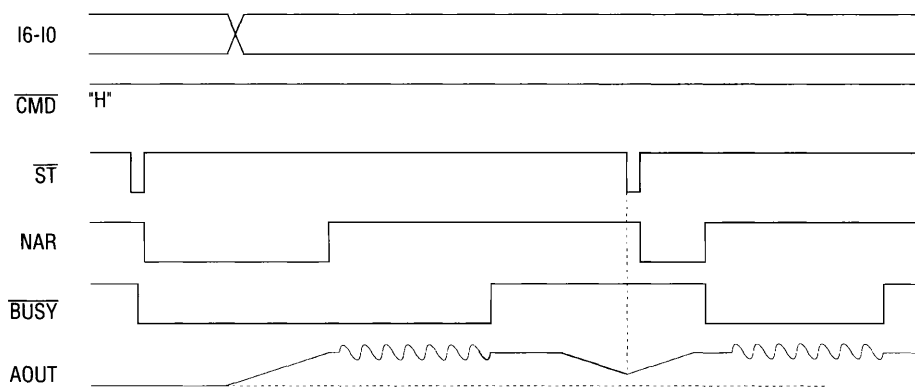

Figure 13.1 $\overline{\text{ST}}$ Pulse Input Timing during Standby Conversion

As shown in Figure 13.1, when $\overline{\text{ST}}$ pulse is input during standby conversion after voice ends, the IC exits from standby status, and the output of AOUT goes $1/2 V_{DD}$. When the output reaches $1/2 V_{DD}$, voice synthesis starts.

14. VOICE OUTPUT

For the voice output pin, a command option can select whether the DA converter output is directly output or output through an internal low-pass filter.

Table 14.1 shows output level of AOUT pin.

Table 14.1 Output Level of AOUT Pin

Regeneration method	Condition	Lowest level	Center level	Highest level
ADPCM	DA converter output	0	approx. $0.5 \times V_{DD}$	approx. V_{DD}
	LPF output	approx. $0.15 \times V_{DD}$	approx. $0.5 \times V_{DD}$	approx. $0.95 \times V_{DD}$
PCM	—	approx. $0.25 \times V_{DD}$	approx. $0.5 \times V_{DD}$	approx. $0.75 \times V_{DD}$
Melody	—	approx. $0.25 \times V_{DD}$	approx. $0.5 \times V_{DD}$	approx. $0.75 \times V_{DD}$
BEEP Tone	—	approx. $0.25 \times V_{DD}$	approx. $0.5 \times V_{DD}$	approx. $0.75 \times V_{DD}$

14.1 D/A Converter Output Wave Form

The output amplitude from the D/A converter becomes a step wave form synchronizing the sampling frequency at a maximum $4095/4096 \times V_{DD}$.

If D/A output is selected, it is recommended to externally attach a low-pass filter. Since the output impedance of a D/A converter changes between $15 \text{ k}\Omega$ to $35 \text{ k}\Omega$, determine the filter constant so that this resistance change does not affect the cutoff frequency of the low-pass filter.

14.2 Low-Pass Filter Output

The low-pass filter consists of switched capacitors. The attenuation characteristic of the MSM6650 family device low-pass filter is -40 dB/oct . The cutoff frequency changes depending on the sampling frequency. The cutoff frequency is 0.4 time as low as the sampling frequency.

Table 14.2 shows the relationship between sampling frequency and cutoff frequency.

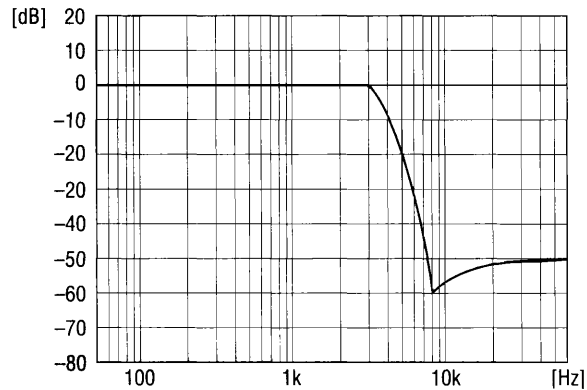

Figure 14.1 LPF Frequency Characteristics ($f_s = 8.0 \text{ kHz}$)

Table 14.2 Cutoff Frequencies of Low-Pass Filter

Sampling Frequency (f_s) (kHz)	Cutoff Frequency (f_{cut}) (kHz)
4.0	approx. 1.8
5.3	approx. 2.6
6.4	approx. 2.6
8.0	approx. 3.2
10.6	approx. 4.2
12.8	approx. 5.1
16.0	approx. 6.4
32.0	approx. 12.8

15. LOW-PASS FILTER POP NOISE

Each device of the MSM6650 family contains a "pop" noise killer circuit. However, a low-pass filter selected may cause "pop" noise as the filter output's circled portions of the figure 15.1 change by approx. 0.7 V abruptly.

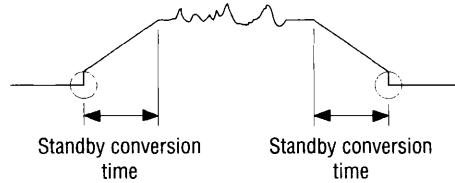

Figure 15.1 Pop Noise of Low-Pass Filter

"Pop" noise can be reduced by connecting a diode at the AOUT output (as shown Figure 15.2).

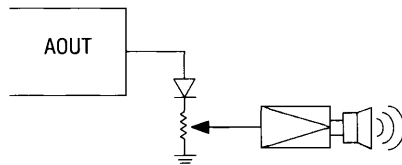

Figure 15.2 Pop Noise Killer Circuit

16. CERAMIC OSCILLATION

Figure 16.1 shows an external circuit diagram using a ceramic oscillator.

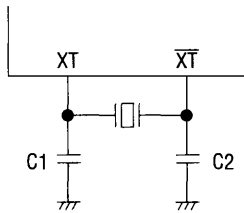

Figure 16.1 External Circuit Diagram

Figures 16.2 and 16.3 show external circuit diagrams using a ceramic oscillator, CSA4.09 MGU and CST4.09MGWU made by Murata MFG. Co., Ltd.

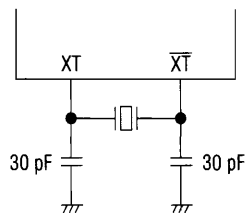

Figure 16.2 CSA4.09MGU

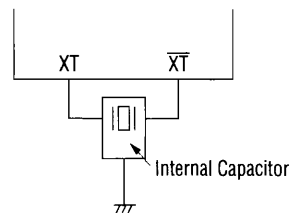

Figure 16.3 CST4.09MGWU

Figure 16.4 shows an external circuit diagram using a ceramic oscillator, PBRC4.00MSA/MKS/MWS made by Kyocera Corp.

When using an oscillator, 4.00 MHz, playback speed is approximately 2% slower than AR761 and AR762 analysis tools and demonstration board.

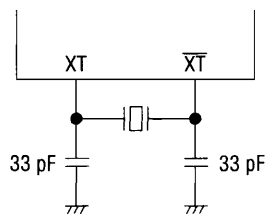
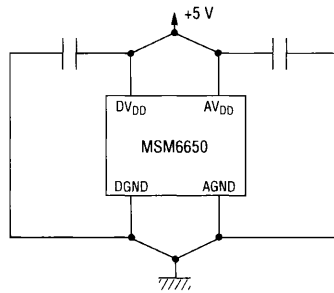

Figure 16.4 PBRC4.00MSA/MKS/MWS

17. POWER SUPPLY (for MSM6650)

The MSM6650 should be powered from a single power source to the analog section and digital section separately, as shown below.



The following power connections are not permitted.

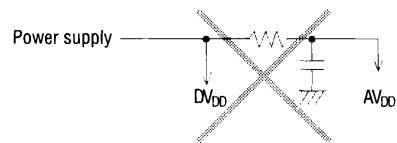
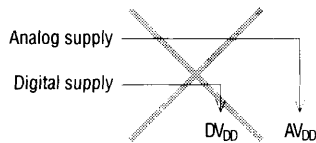

18. EXTERNAL ROM DRIVING TIMING (for MSM6650)

The figure 18.1 shows an external ROM driving timing during playback at $f_{OSC} = 4.096$ MHz and $f_S = 4.096$ KHz.

Tables 18.1 and 18.2 show f_S data and playback method data, respectively.

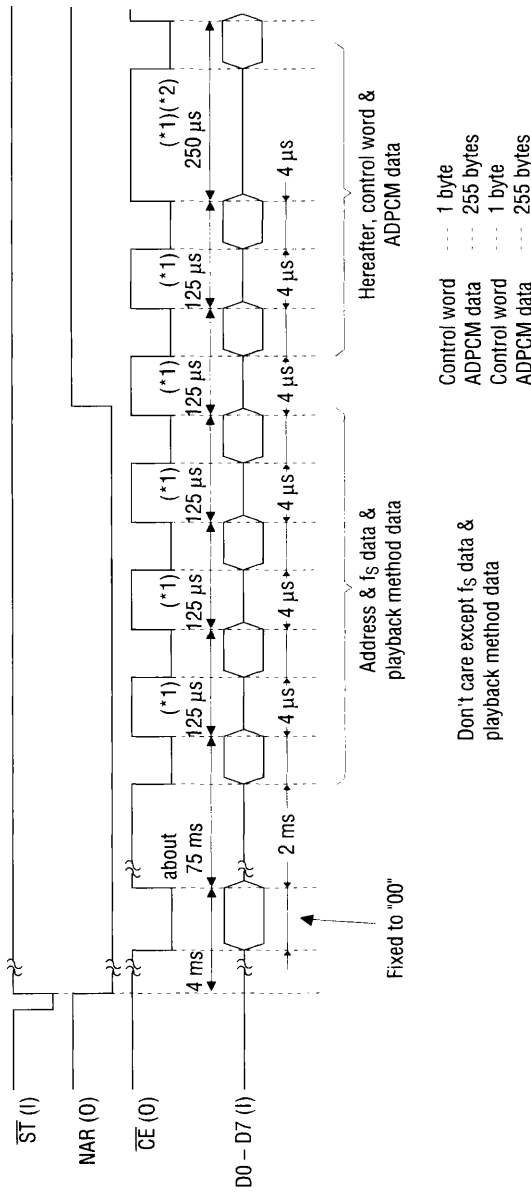

All data are created using voice analysis edit tools AR76-202 and AR203.

*1 Changes depending on f_S .
 *2 Hereafter, CE, D7-D0 are input or output at intervals of 250 μs or 125 μs .

Figure 18.1 External ROM Driving Timing

Table 18.1 f_s Data

O2	O1	O0	Sampling frequency (kHz)
0	0	0	8.0
0	0	1	10.7
0	1	0	12.8
0	1	1	32.0
1	0	0	4.0
1	0	1	5.3
1	1	0	6.4
1	1	1	16.0

Table 18.2 Playback Method Data

O7	O6	Playback method
0	0	Playback by ADPCM
0	1	Playback by PCM
1	0	Playback by melody

APPLICATION CIRCUITS

(MSM6652/53/54/55/56-XXX, MSM6652A/53A/54A/55A/56A/58A-XXX, MSM66P54-XX)

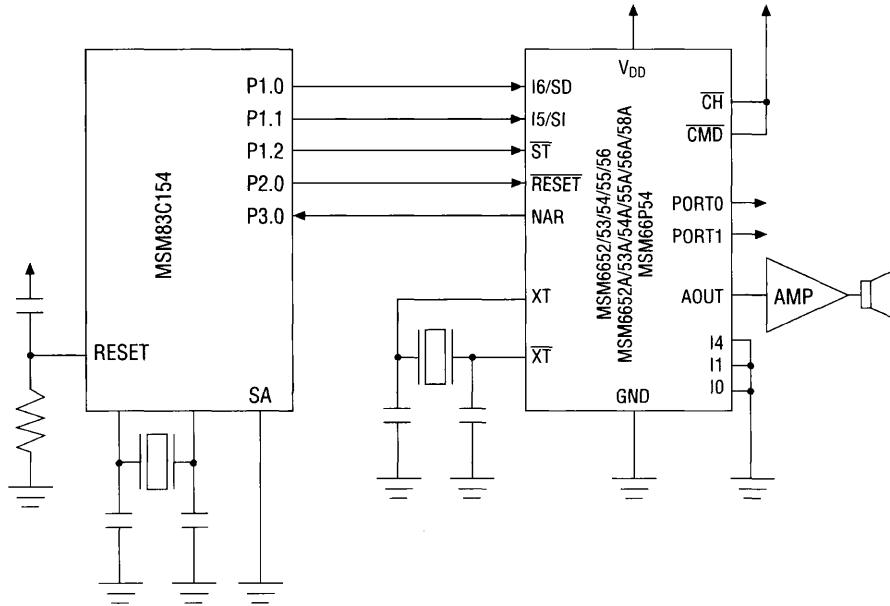

Application Circuit in Serial Input Interface Mode

(MSM6652/53/54/55/56-XXX, MSM6652A/53A/54A/55A/56A/58A-XXX, MSM66P54-XX)

(Continued)

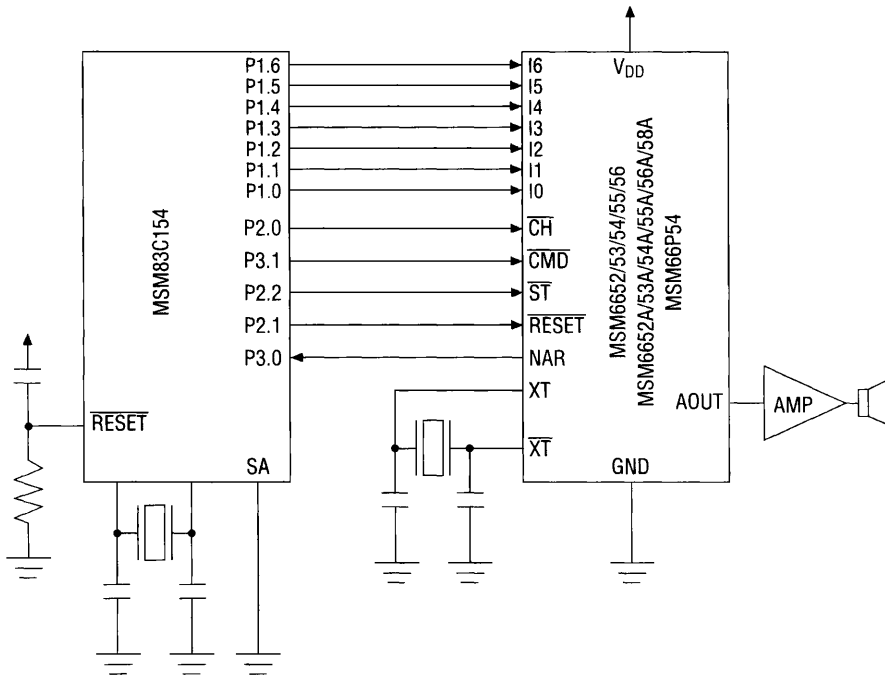

Application circuit in Parallel Input Interface Mode

(MSM6650) (Continued)

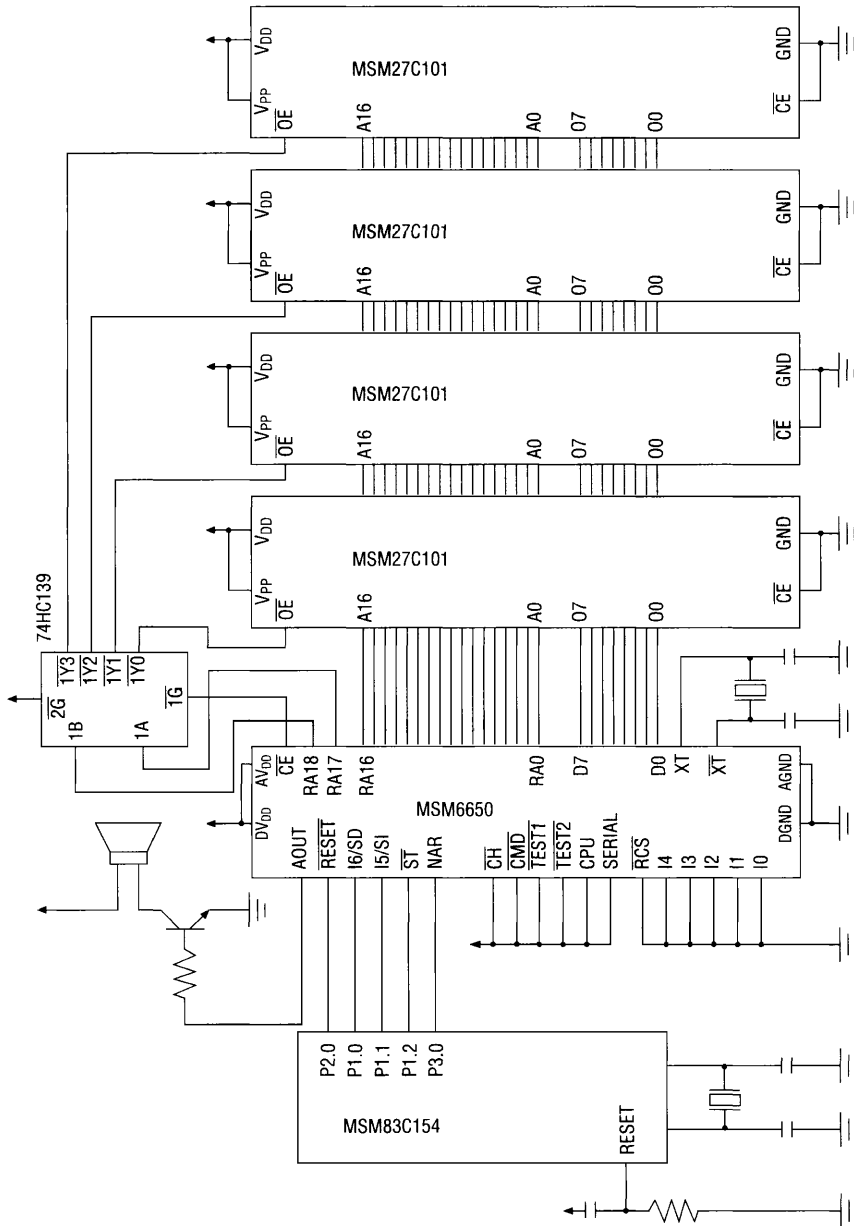

Application Circuit in Microcontroller Interface Mode
Using Four 1-Mbit EPROMs (Serial Input Interface)

(MSM6650) (Continued)

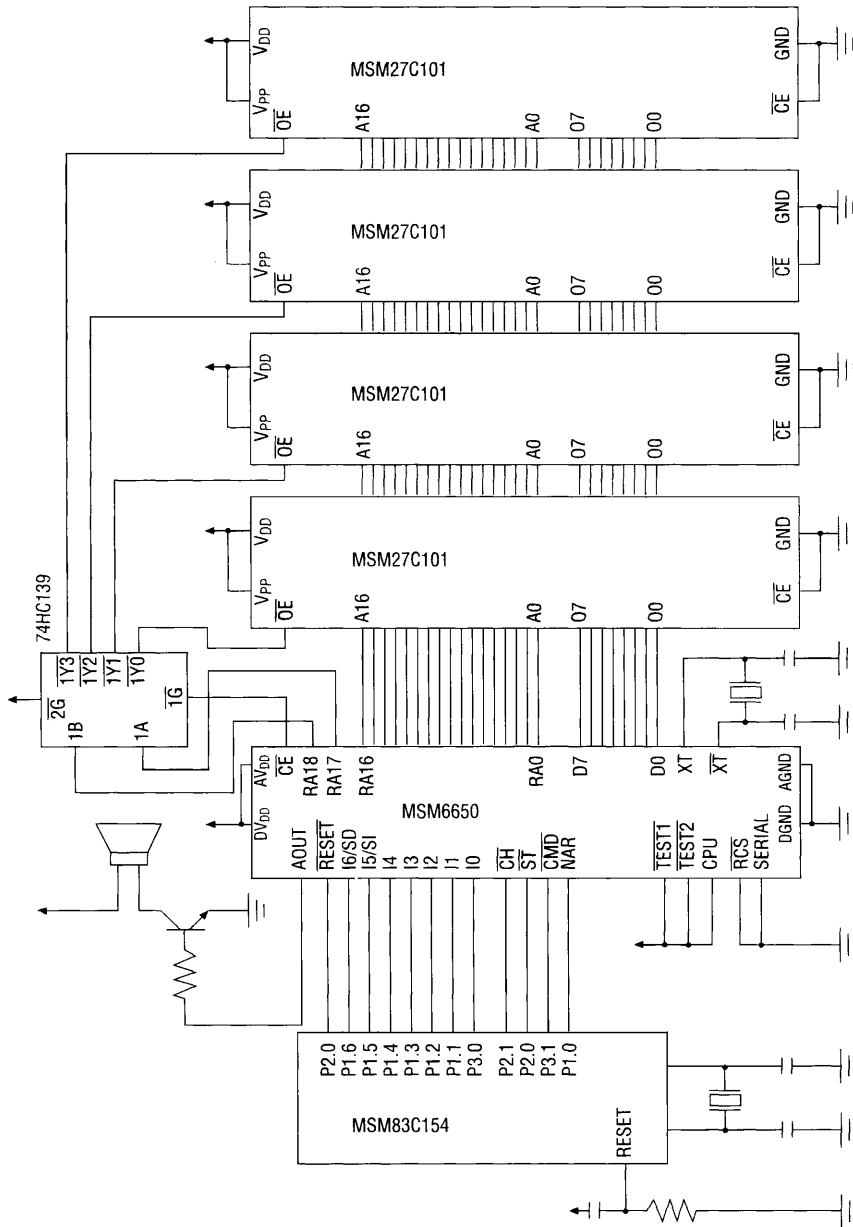

Application Circuit in Microcontroller Interface Mode Using Four 1-Mbit EPROMs (Parallel Input Interface)

COMMON

EDIT ROM

The role of edit ROM is to link phrases and build sentences, which makes an external microcontroller unnecessary. The conventional MSM6375 family could not link phrases and synthesis channels in standalone mode, but the MSM6650 family can use the edit ROM.

For example: The phrase "Today's weather is...." can be used to illustrate the differences between the MSM6375 family and MSM6650. With the MSM6375 family (in stand-alone operation), individual data must be stored as a phrase in ROM (see Table 1) then for playback each phrase must be addressed individually. Example: "Today's weather is sunny", and "Today's weather is rainy".

On the other hand, the MSM6650 family has edit ROM functions which eliminate the need for an external microcontroller to provide the continuous timing necessary for voice concatenation, as with the MSM637x family. This means that individual phrases or words which are stored in phrase ROM can be concatenated in the edit ROM and assigned a single address according to their content. This feature allows for efficient use of memory for phrase storage in ROM. Table 2 shows phrases/words stored in ROM and their addresses, Table 3 shows how you can combine the phrase/word addresses (up to a maximum of 8) in the edit ROM to achieve fully concatenated phrases.

Conventionally data must be repeatedly stored to phrase ROM to vocalize "Today's weather is....", but overlapped data is not required as shown in Table 2 by using edit ROM functions.

Table 1 Conventional Phrase ROM Configuration

Address [HEX]	Phrase
01	Today's weather is sunny.
02	Today's weather is rainy.
03	Today's weather is sunny becoming cloudy, some areas are rainy.
5	⋮
7F	

Table 2 Phrase ROM Configuration

Address [HEX]	Phrase
01	Today's
02	weather
03	is
⋮	⋮
10	sunny
11	cloudy
12	rainy
13	snowy
20	occasional
21	becoming
22	some areas are
⋮	⋮
7F	

Table 3 Edit ROM Configuration

Address [HEX]	Edit Content [Max. 8 Phrases]
01	[01][02][10][03]
02	[01][02][12][03]
03	[01][02][10][21][11][22][13][03]
⋮	⋮
7F	

The edit ROM makes channel synthesis possible, a feature previously not available in standalone mode with the MSM6375 series. With edit ROM commands, phrase linking, channel synthesis and "BEEP" tone or "silence" can be set.

A maximum of 8 phrases (16 bytes) per phrase address can be set using the edit ROM feature. Table 4 shows the edit ROM configuration.

Table 4 Edit ROM Configuration

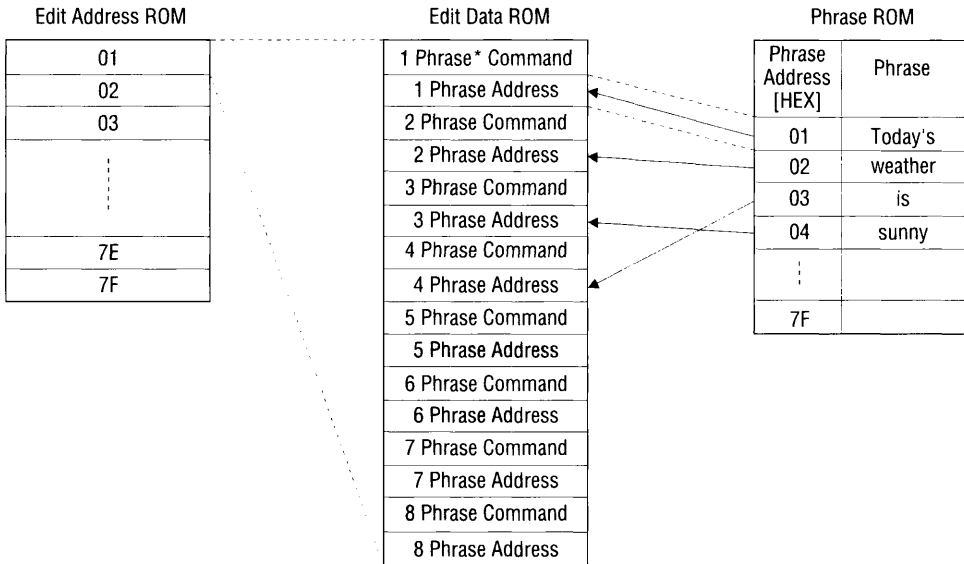

* The word "phrase" as used here includes any of the following: voice, music, BEEP tones or silence.

Edit ROM details—The "phrase ROM" consists of up to a maximum of 127 phrases, the "edit ROM" allows you to choose up to any 8 of the 127 phrases in the "phrase ROM". The "edit data ROM" contains both phrase address and command data. Each address in the "edit address ROM" can contain up to 8 phrases in the "edit data ROM". Therefore, each of the 127 edit ROM addresses available can represent a single phrase or up to 8 phrases (for concatenation).

The phrase ROM cannot be directly accessed if the edit ROM is used.

Figure 1 shows the flowchart when creating an edit ROM using the AR76-202 development tool.

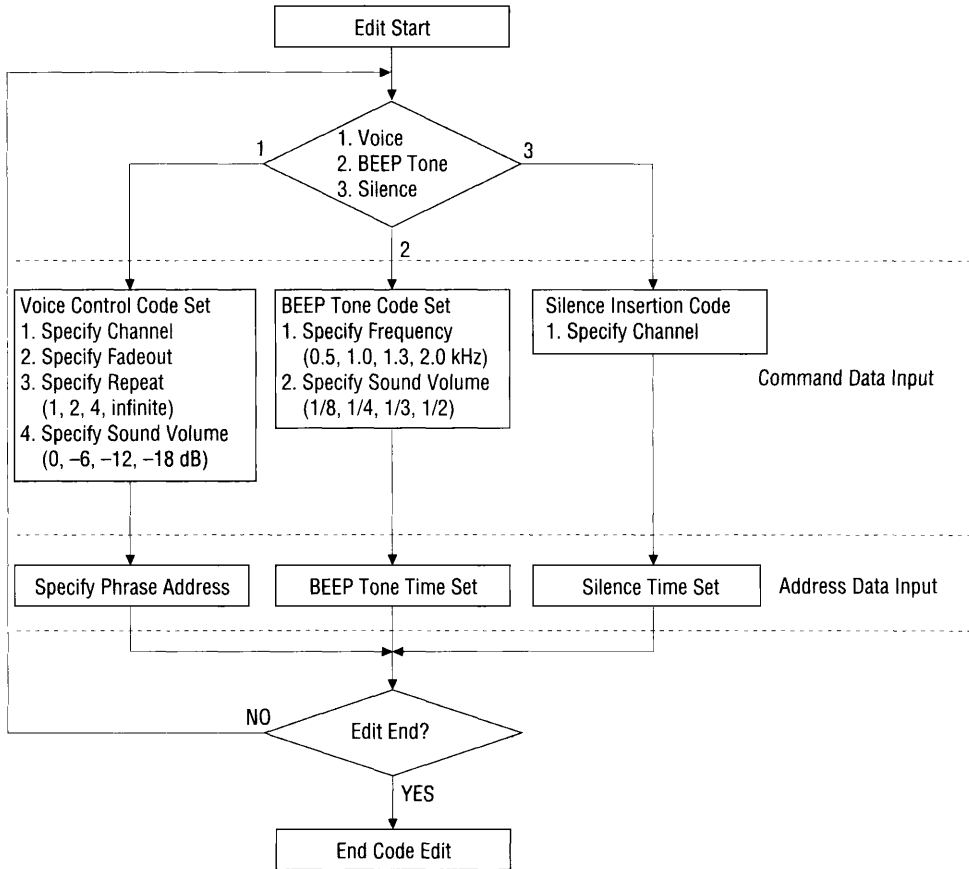

Figure 1 Edit Data ROM Flowchart

1. EDIT ROM COMMANDS

Table 5 shows the commands that can be set in the edit ROM.

Table 5 List of Edit ROM Commands

O7	O6	O5	O4	O3	O2	O1	O0	Command
0	0	0	0	0	0	0	0	End Code
ch	0	1	0	0	0	0	0	Silence Insertion Code
1	1	0	0	bf1	bf0	bf1	bf0	BEEP Tone Code
ch	1	1	sm	rp1	rp0	vl1	vl0	Voice Control Code

Each of the edit ROM commands in Table 5 are explained below.

1.1 End Code

The end code is used at the completion of a phrase. The MSM665X family recognizes the end code which is necessary when the edit ROM contains only a single phrase. When the maximum number of phrases is selected (8) the end code is unnecessary.

1.2 Silence Insertion Code

Silence insertion code inserts silence in the specified channel, reducing voice data.

O7	O6	O5	O4	O3	O2	O1	O0
ch	0	1	0	0	0	0	0

The channel for silence insertion is specified in the command data, while the silence time is set in the address data.

Command data bit O7 (CH) specifies into which channel silence will be inserted, a "1" in data bit O7 selects channel 1 while a "0" selects channel 2.

Silence time is set at the address settings of phrases shown in Table 4.

Minimum Silence Time 16.384 ms

Maximum Silence Time 2.1 sec.

The formula to set the silence time is shown below.

$$t_{MU} = (2^6 \times (O6) + 2^5 \times (O5) + 2^4 \times (O4) + 2^3 \times (O3) + 2^2 \times (O2) + 2^1 \times (O1) + 2^0 \times (O0)) \times 16.384 \text{ ms}$$

Table 6 Edit Data Example of Silence insertion Coding

	O7	O6	O5	O4	O3	O2	O1	O0	
1st Byte	1	0	1	0	0	0	0	0	Silence Insertion Code
2nd Byte	0	0	0	1	1	0	0	0	Silence Time
3rd Byte	0	0	0	0	0	0	0	0	End Code

For example, if edit data is set as in Table 6, 393 ms of silence is inserted to channel 1.

1.3 BEEP Tone Code

The BEEP tone code produces a BEEP tone from an internal circuit which is independent of the ADPCM circuitry. The sound volume and frequency of a BEEP tone is set in command data, while the playback time of a BEEP tone is set in the address data.

The BEEP tone can be set only in channel 1.

The sound volume is set at data bits O3, O2 and the frequency is set at data bits O1, O0.

O7	O6	O5	O4	O3	O2	O1	O0
1	1	0	0	bf1	bf0	bf1	bf0

Tables 7 and 8 show the sound volumes and the frequencies that can be set.

Table 7 Sound Volume Settings

O3	O2	Sound Volume
0	0	1/8 amplitude sound volume of channel 1
0	1	1/4 amplitude sound volume of channel 1
1	0	1/3 amplitude sound volume of channel 1
1	1	1/2 amplitude sound volume of shannel 1

Table 8 Frequency Settings

O1	O0	Frequency
0	0	0.5 kHz
0	1	1.0 kHz
1	0	1.3 kHz
1	1	2.0 kHz

The BEEP tone time is set in the phrase address setting of the edit data ROM shown in Table 4.

Minimum BEEP Tone Time 16.384 ms
 Maximum BEEP Tone Time 2.1 sec.

The formula to set a BEEP Tone time is shown below.

$$t_{BE} = (2^6 \times (O6) + 2^5 \times (O5) + 2^4 \times (O4) + 2^3 \times (O3) + 2^2 \times (O2) + 2^1 \times (O1) + 2^0 \times (O0)) \times 16.384 \text{ ms}$$

Table 9 Edit Data Example of BEEP Tone Coding

	O7	O6	O5	O4	O3	O2	O1	O0	
1st Byte	1	1	0	0	1	1	0	1	BEEP Tone Code
2nd Byte	0	0	0	1	1	0	0	0	BEEP Tone Time
3rd Byte	0	0	0	0	0	0	0	0	End Code

For example, if edit data is set as in Table 9, a 1.0 kHz BEEP tone is played back at a 1/2 amplitude sound volume in channel 1 for 393 ms.

1.4 Voice Control Code

The voice control code sets repeat and sound volume.

O7	O6	O5	O4	O3	O2	O1	O0
ch	1	1	sm	rp1	rp0	vl1	vl0

The channel is set with data bits "O7". If bit "O7" is "H", channel 1 is selected, if "L" channel 2 is set. The voice control condition of each channel is set using bits O0-O4.

(1) Setting the Number of Repeats

The number of repeats is set with data bits O3 and O2, and can be selected from 4 types: 1, 2, 4 and infinite. If infinite is selected, repeat can be stopped by switching to another phrase.

Table 10 shows the relationship between O3, O2 and the number of repeats.

Table 10 Number of Repeats Settings

O3	O2	Number of Repeats
0	0	1
0	1	2
1	0	4
1	1	Infinite

(2) Sound Volume Smoothing During Repeat

If data bit "O4" is set to a "1", sound volume during repeat is attenuated from 1 to 1/2, 1/4 and 1/8. This smoothing, however, is effective only when 2, 4 or infinite is selected for the repeat setting.

If infinite is selected, voice is played, remaining at 1/8 sound volume after attenuating from 1 to 1/2, 1/4 and 1/8. If the initial sound volume setting is other than 1, the sound volume attenuates from that value in 1/2 units, stopping at 1/8.

(3) Setting Sound Volume

Voice volume can be changed in 4 steps if voice playback overlaps during channel mixing. The sound volume is set with data bits O1 and O0. Table 11 shows the corresponding data and attenuation values.

Table 11 Volume Attenuation Setting

O1	O0	Volume Attenuation
0	0	No attenuation (sound volume is same as voice data)
0	1	-6 dB attenuation (sound volume is 1/2 of voice data)
1	0	-12 dB attenuation (sound volume is 1/4 of voice data)
1	1	-18 dB attenuation (sound volume is 1/8 of voice data)

2. PCM PLAYBACK USING THE EDIT ROM

For PCM playback, edit data is set together with the voice control data. Items which can be set in the voice control code include (channel, sound volume smoothing during repeat, number of repeats, and sound volume).

3. MELODY PLAYBACK USING THE EDIT ROM

For melody playback, edit data is set together with the voice control data. Channels however cannot be set. Channel 1 is fixed. Channel 2 mixing of melodies is not possible.

4. RANDOM PLAYBACK USING THE EDIT ROM

If the $\overline{\text{RND}}$ pin is used during random playback, the 1st edit phrase (which consists of an edit data ROM sequence up to 8 phrases/16 bytes) is played and the random playback of the 2nd edit phrase then starts random play continuously.

Random play requires the channel setting for the 1st and 2nd edit phrases to be the same. Random play cannot be used during channel 2 play or echo play without the use of the silence insertion technique shown in figure 10 item (2). Figure 2 item (1) shows the overlapping of the 2nd edit phrase in channel 1 with the echo playback of channel 2. Item (2) shows how silence is inserted after the 1st edit phrase in channel 1 to avoid overlapping of the 2nd edit phrase with channel 2 playback.

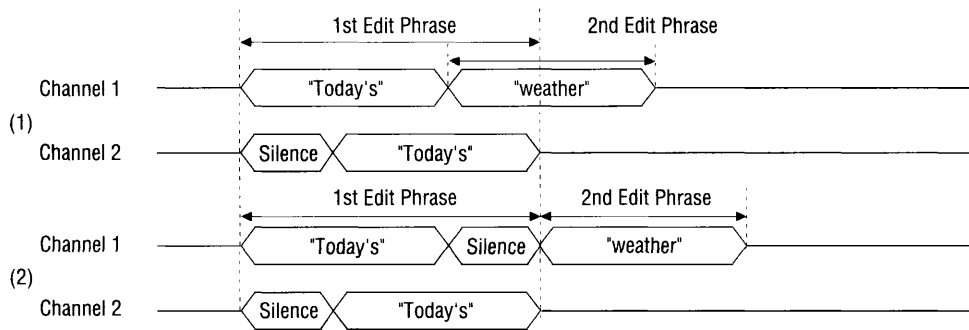

Figure 2 Example of Random Vocalization Timing

5. CHANNEL 2 MIXING FUNCTION IN THE EDIT ROM

This function overlaps 2 phrases. By using edit ROM, it is easy to echo a phrase (echo play) and to a phrase with BGM (background music, in channel 2).

5.1 Echo Playback

Echo playback delays and overlaps the phrase played in channel 1 at -6 dB attenuation (1/2 amplitude of channel 1) in channel 2.

ECHO PLAYBACK OF A SINGLE PHRASE

Using address [02] of the phrase ROM, "weather", an example is shown with echo of a single phrase.

Table 12 Edit Data Example of Echo Playback of a Single Phrase

	O7	O6	O5	O4	O3	O2	O1	O0	
1st Byte	1	1	1	0	0	0	0	0	Voice Control Code (CH1 select, repeat, -6 dB attenuation)
2nd Byte	0	0	0	0	0	0	1	0	Phrase Address (02H "weather")
3rd Byte	0	0	1	0	0	0	0	0	Silence Insertion Code (CH2 select)
4th Byte	0	0	0	0	0	1	1	0	Silence Time (98.3 ms)
5th Byte	0	1	1	0	0	0	0	1	Voice Control Code (CH2 select, repeat, -12 dB attenuation)
6th Byte	0	0	0	0	0	0	1	0	Phrase Address (02H "weather")
7th Byte	0	0	0	0	0	0	0	0	End Code

If edit data is set as in Table 12, "weather" is played in channel 1, and is overlapped during playback from channel 2 at -6 dB attenuated sound volume 98.3 ms after the start of channel 1 play.

When two phrases overlap set the attenuation of the voice control command with attention to sound volume to prevent clipping.

Be aware that the silence time is an element that influences the echo quality. Set the silence time so that the desired echo is created.

When using echo play set the number of repeats of the voice control command to 1. If 2, 4 or infinite is set, timing becomes as shown in Figure 3.

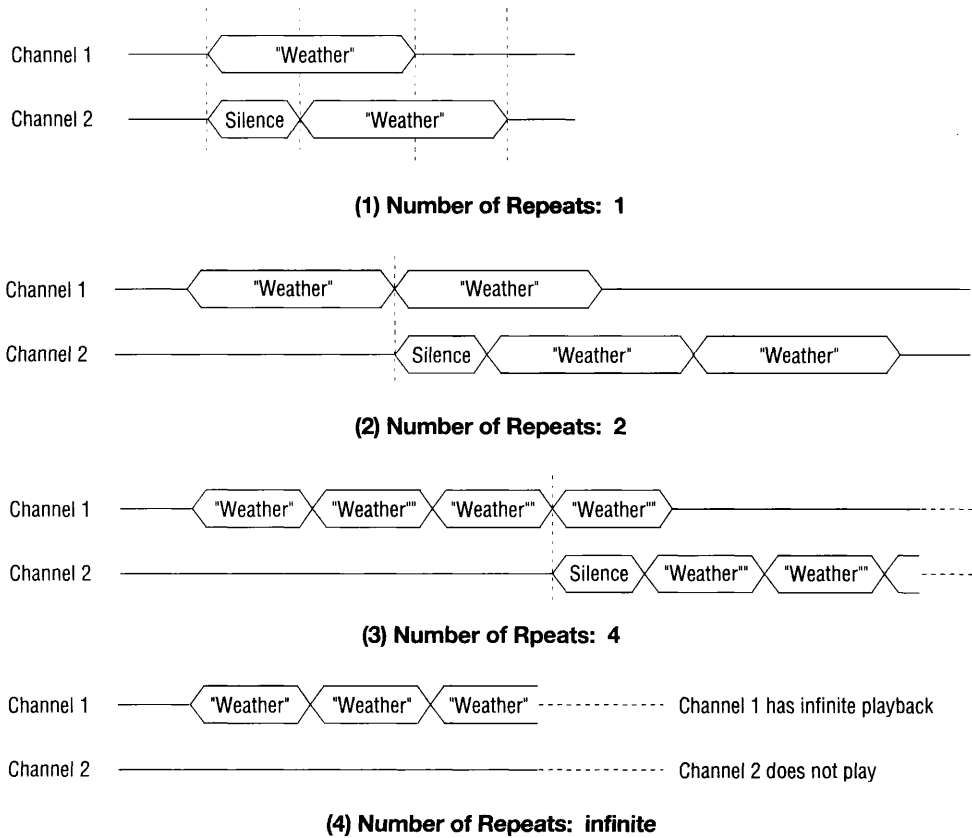

Figure 3 Echo Playback Timing Using Repeated Playback

The echo playback timing, during repeated paly which is assigned with the voice control command for an edit data phrase, is explained below.

(1) When the number of repeats is set to 1

When the same channel is selected for playback of the next phrase, playback of the next phrase starts after playback of the 1st phrase ends. If the channel of the next phrase is different (channel 2), then channel synthesis (playback of channels 1 and 2) begins at the start of playback.

(2) When the number of repeats is set to 2

When the same channel is selected for playback of the next phrase, playback of the next phrase starts after playback of the 2nd phrase ends. If the channel of the next phrase is different (channel 2), then channel synthesis at the start of the second phrase playback. Echo does not occur under these conditions because channels 1 and 2 are played simultaneously. A silence insertion code must be applied to channel 2 for echo to occur, playback in channel 2 is then delayed with respect to channel 1 which causes echo (see Figure 3). The amount of echo depends on the duration of the silence in channel 2.

(3) When the number of repeats is set to 4

When the same channel is selected for playback of the next phrase, playback of the next phrase starts after playback of the 4th phrase ends. If the channel of the next phrase is different (channel 2), then channel synthesis (playback of channels 1 and 2) begins at the start of the 4th phrase playback. Echo does not occur under these conditions because channels 1 and 2 are played simultaneously. A silence insertion code must be applied to channel 2 for echo to occur, playback in channel 2 is then delayed with respect to channel 1 which causes echo (see Figure 3). The amount of echo depends on the duration of the silence in channel 2.

(4) When the number of repeats is set to infinite

The next phrase becomes invalid and is not played regardless of the channel specification (see Figure 3 (4)).

ECHO PLAYBACK OF MULTIPLE PHRASES

A maximum of eight phrases (16 bytes) can be set to the edit data ROM. Up to three phrases can be set for echo play with 16 bytes. The phrase ROM should be set so that the number of phrases does not exceed four. Using "Today's", "weather" and "is" of the phrase ROM in Table 2 as an example, Table 13 shows echo playback of three phrases. Figure 4 shows the playback timing.

Table 13 Edit Data Example – Three Phrase Echo Playback

	07	06	05	04	03	02	01	00	
1st Byte	1	1	1	0	0	0	0	1	Voice Control Code (CH1 select, repeat once, -6 dB attenuation)
2nd Byte	0	0	0	0	0	0	0	1	Phrase Address (01H "Today's")
3rd Byte	0	0	1	0	0	0	0	0	Silence Insertion Code (CH2 select)
4th Byte	0	0	0	0	0	1	1	0	Silence Time (98.3 ms)
5th Byte	0	1	1	0	0	0	1	0	Voice Control Code (CH2 select, repeat once, -12 dB attenuation)
6th Byte	0	0	0	0	0	0	0	1	Phrase Address (01H "Today's")
7th Byte	1	1	1	0	0	0	0	1	Voice Control Code (CH1 select, repeat once, -6 dB attenuation)
8th Byte	0	0	0	0	0	0	1	0	Phrase Address (02H "weather")
9th Byte	0	1	1	0	0	0	1	0	Voice Control Code (CH2 select, repeat once, -12 dB attenuation)
10th Byte	0	0	0	0	0	0	1	0	Phrase Address (02H "weather")
11th Byte	1	1	1	0	0	0	0	1	Voice Control Code (CH1 select, repeat once, -6 dB attenuation)
12th Byte	0	0	0	1	0	0	0	0	Phrase Address (10H "is")
13th Byte	0	1	1	0	0	0	1	0	Voice Control Code (CH2 select repeat once, -12 dB attenuation)
14th Byte	0	0	0	1	0	0	0	0	Phrase Address (10H "is")
15th Byte	1	1	1	0	0	0	1	1	Voice Control Code (CH1 select, repeat once, -6 dB attenuation)
16th Byte	0	0	0	0	0	0	1	1	Phrase Address (03H "sunny")

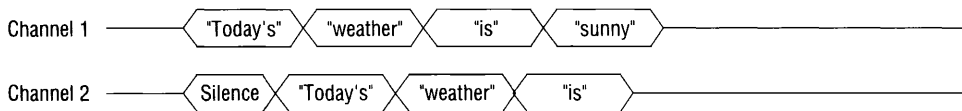

Figure 4 Playback Timing of Three Phrases with Echo

For the echo playback of multiple phrases, the sampling frequency of each phrase must be the same. If a phrase with a different sampling frequency is mixed, the voice of channel 2 (ECHO) will be played fast or slow because the sampling frequency of channel has priority. Figure 5 shows the timing.

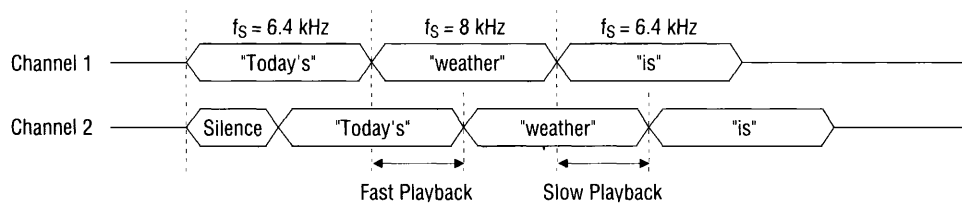

Figure 5 Echo Playback Timing with Different Sampling Frequencies

ECHO PLAYBACK OF A SINGLE PHRASE WITHIN A PHRASE STRING

Table 14 shows an edit data example to apply echo to "is" in the four phrases of "Today's", "weather", "is" and "sunny".

Table 14 Edit Data Example of a Single Phrase within a Phrase String

	O7	O6	O5	O4	O3	O2	O1	O0	
1st Byte	1	1	1	0	0	0	0	0	Voice Control Code (CH1 select, repeat once, no attenuation)
2nd Byte	0	0	0	0	0	0	0	1	Phrase Address (01H "Today's")
3rd Byte	0	0	1	0	0	0	0	0	Silence Insertion Code (CH2 select)
4th Byte	0	1	1	0	0	0	0	1	Silence Time (1.59 sec)
5th Byte	1	1	1	0	0	0	0	0	Voice Control Code (CH1 select, repeat once, no attenuation)
6th Byte	0	0	0	0	0	0	1	0	Phrase Address (02H "weather")
7th Byte	1	1	1	0	0	0	0	0	Voice Control Code (CH1 select, repeat once, no attenuation)
8th Byte	0	0	0	1	0	0	0	0	Phrase Address (10H "is")
9th Byte	0	1	1	0	0	0	0	1	Voice Control Code (CH2 select, repeat once, -6 dB attenuation)
10th Byte	0	0	0	1	0	0	0	0	Phrase Address (10H "is")
11th Byte	1	1	1	0	0	0	0	0	Voice Control Code (CH1 select, repeat once, no attenuation)
12th Byte	0	0	0	0	0	0	1	1	Phrase Address (03H "sunny")
13th Byte	0	0	0	0	0	0	0	0	End Code

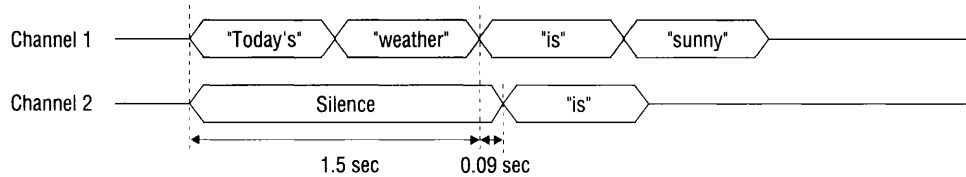

Figure 6 Playback Timing Using Table 14 Edit Data

As shown by the timing in Figure 6, "is" is echoed by setting the silence time to delay playback of channel 2 echo. While channel 1 plays four consecutive phrases, the silence time has been set so that channel 2 play is delayed until the selected phrase in channel 1 can be echoed. If the silence time exceeds 2.1 sec, it is necessary to add a silence insertion setting to 2 bytes of the edit data.

A maximum of 6 phrases are possible if the silence insertion setting is 2 bytes.

5.2 Two-Channel Playback

Two-channel play uses PCM, memory and ADPCM methods. Channel mixing is possible with all combinations except melody play/melody play (in channel 2). Melody play is in channel 1 only. The sampling frequency of phrases which overlap must be the same.

Figures 7 to 10 show 2 channel playback timing.

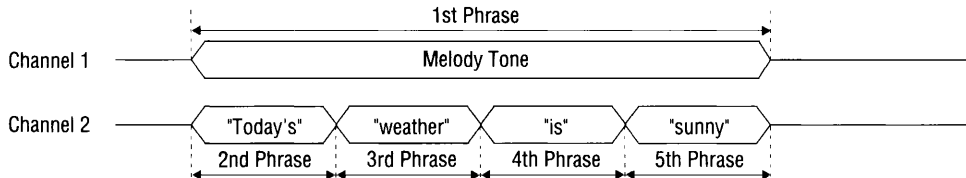

Figure 7 Timing of Four Phrase Channel Mixing with a Melody Tone as BGM (Background Music)

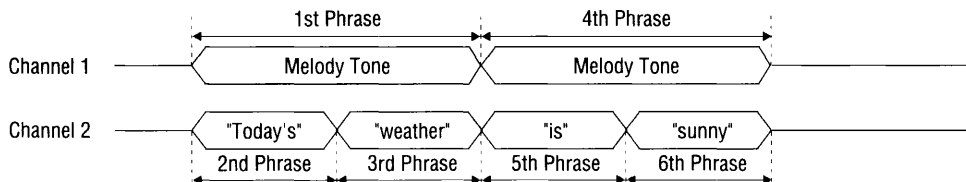

Figure 8 Timing of Four Phrase Channel Mixing with a Melody Tone for 1st and 4th Phrases as BGM (Background Music)

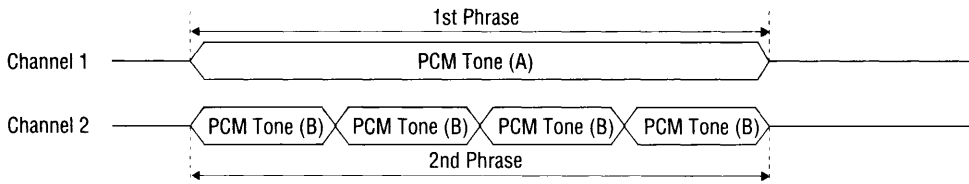

Figure 9 Channel Mixing between PCM Main Melody Tone (A) and PCM Rhythm Tone (B) with 4 Repeats

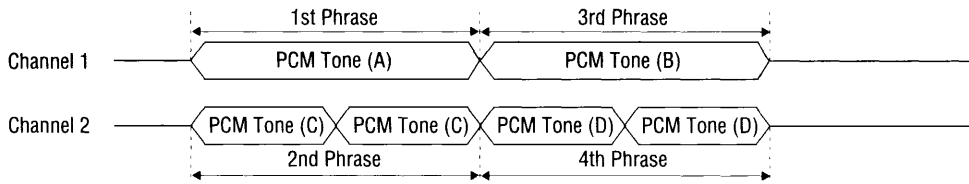

Figure 10 Channel Synthesis between PCM Main Melody Tone (A) (B) and PCM Rhythm Tone (C) (D) with 2 Repeats