

---

# ML9479B

---

Static, 1/2 Duty, 1/3 Duty, 1/4 Duty 160 Outputs LCD Driver

---

## GENERAL DESCRIPTION

The ML9479B is a LCD driver LSI, consists of an 160-bit shift register, a 640-bit data latch, 160 sets of LCD drivers, and a common signal generation circuit.

It can directly drive an LCD up to 160 segments for static display, 320 segments for 1/2-duty display, 480 segments for 1/3-duty display, and 640 segments for 1/4-duty display.

The three-wire serial interface and I<sup>2</sup>C interface are selectable.

## FEATURES

- Logic power supply voltage : 2.7 to 5.5 V
- LCD drive power supply voltage : 4.5 to 5.5 V
- Maximum number of segments
  - Static display : 160 segments
  - 1/2-duty display : 320 segments
  - 1/3-duty display : 480 segments
  - 1/4-duty display : 640 segments
- Interface with microcomputer :
  - Serial interface : DATA, CLOCK, LOAD
  - CLOCK transfer speed up to 1 MHz
  - I<sup>2</sup>C interface : SDA, SCL, SDAACK
  - SCL transfer speed up to 400 kHz
- Built-in CR oscillator circuit using the internal resistor or External resistor
- Cascade connectable (up to eight chips)
- Built-in common signal generation circuit
- Built-in common output intermediate-value voltage generation circuit
- Built-in POC (Power On Clear) circuit
- Gold bump chip (ML9479BDVWA)

**BLOCK DIAGRAM**

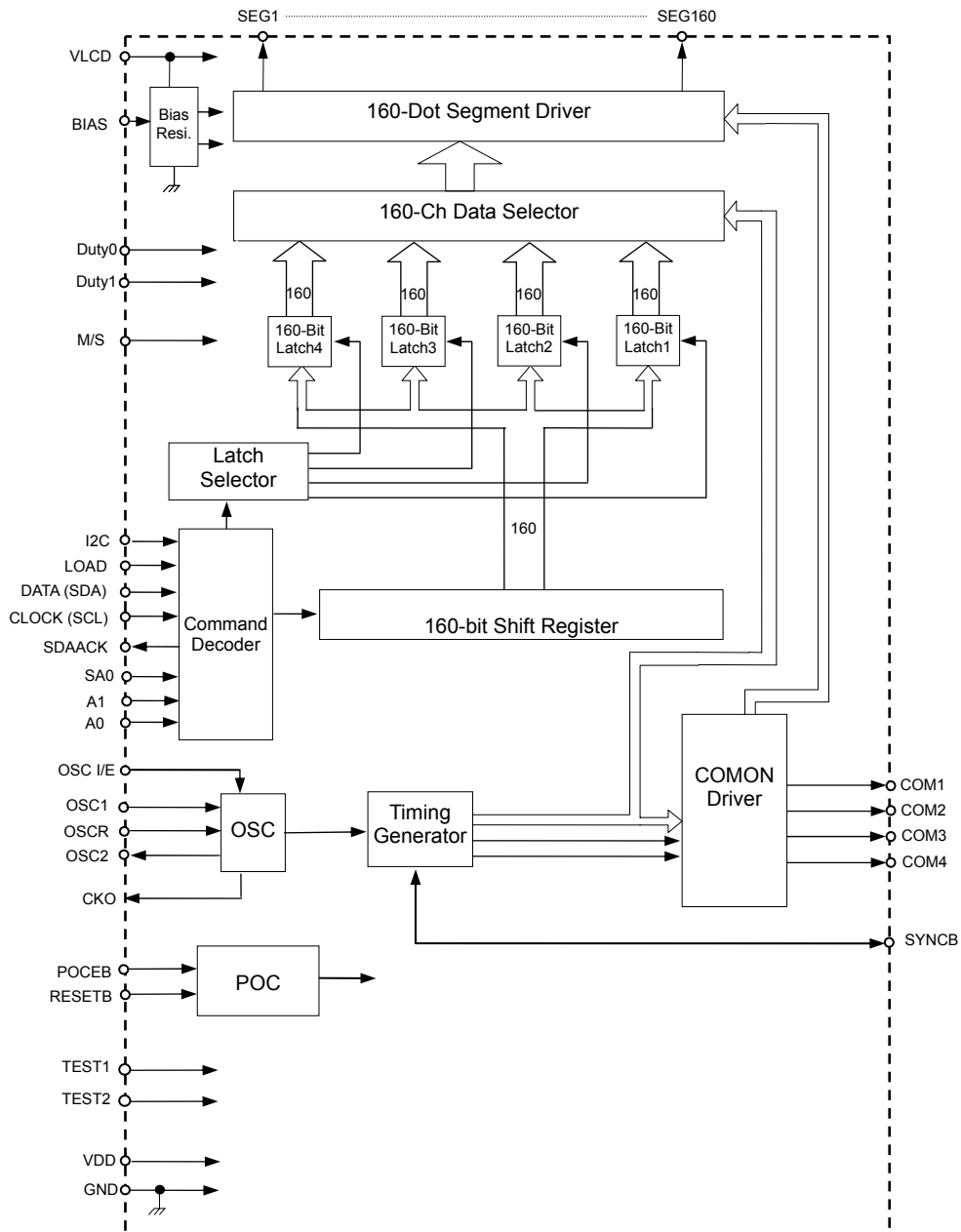

**ABSOLUTE MAXIMUM RATINGS**

Item	Symbol	Condition	Rating	Unit
Logic power supply voltage	V <sub>DD</sub>	T <sub>a</sub> = 25°C	-0.3 to 6.0	V
LCD drive power supply voltage	V <sub>LCD</sub>	T <sub>a</sub> = 25°C	-0.3 to 6.0	V
Input voltage	V <sub>I</sub>	T <sub>a</sub> = 25°C	GND – 0.3 to V <sub>DD</sub> + 0.3	V
Output short-circuit current	I <sub>S</sub>	T <sub>a</sub> = 25°C	-2.0 to +2.0	mA
Chip temperature	T <sub>C</sub>	—	125	°C
Storage temperature	T <sub>STG</sub>	—	-55 to +150	°C

Note: Do not use the ML9479B by short-circuiting one output pin to another output pin as well as to other pin (input pin, input/output pin, or power supply pin).

**RECOMMENDED OPERATION CONDITIONS**

Item	Symbol	Condition	Range	Unit
Logic power supply voltage	V <sub>DD</sub> *	—	2.7 to 5.5	V
LCD drive power supply voltage	V <sub>LCD</sub> *	—	4.5 to 5.5	V
OSC IN clock frequency	f <sub>CP1</sub>	—	up to 10	kHz
Data clock frequency	f <sub>CP2</sub>	—	up to 1.0	MHz
SCL clock frequency	f <sub>SCL</sub>	—	up to 400	kHz
Operating temperature	T <sub>a</sub>	—	-40 to +105	°C

Note(\*): Use at V<sub>DD</sub> ≤ V<sub>LCD</sub>.

The relation between OSC IN clock frequency and frame frequency is as the equation below.

$$f_{\text{FRM}} = f_{\text{OSC}} / 24$$

**Recommended setting range for external component (oscillator circuit)**

(V<sub>DD</sub> = 2.7 to 5.5 V, V<sub>LCD</sub> = 4.5 to 5.5 V, T<sub>a</sub> = –40 to +105°C)

Item	Symbol	Condition	Min	TYP	Max	Unit
Oscillation resistor	R <sub>f</sub>	—	423	470	517	kΩ
Frame frequency	f <sub>FRM</sub>	(F1,F0)=(0,1)	47	75	114	Hz

The relation between oscillation resistor and frame frequency is as the equation below.

$$f_{\text{FRM}} = f_{\text{OSC}} / (16 \times 24)$$

$$f_{\text{OSC}} = 1 / (\text{Device coefficient} \times \text{External resistor } R_f)$$

$$\text{Device coefficient} = 73.8 \times 10^{-12} \pm 25\%$$

## ELECTRICAL CHARACTERISTICS

### DC Characteristics

( $V_{DD} = 2.7$  to  $5.5$  V,  $V_{LCD} = 4.5$  to  $5.5$  V,  $T_a = -40$  to  $+105^\circ\text{C}$ )

Item	Symbol	Condition	Min.	Typ.	Max.	Unit	Applicable pin	
"H" input voltage	$V_{IH}$	—	$0.8V_{DD}$	—	$V_{DD}$	V	(*1)	
"L" input voltage	$V_{IL}$	—	GND	—	$0.2V_{DD}$	V	(*1)	
Input leakage current 1	$I_{L1}$	$V_i = V_{DD}$ or $0$ V	-1.0	—	1.0	$\mu\text{A}$	(*1)	
Input leakage current 2	$I_{L2}$	$V_i = V_{DD}$ or $0$ V POCEB = "H"	-1.0	—	1.0	$\mu\text{A}$	RESETB	
Pull-up current	$I_{pu}$	$V_{DD} = 5.0$ V, $V_i = 0$ V POCEB = "L"	30	—	140	$\mu\text{A}$	RESETB	
"H" output voltage	$V_{OH}$	$I_o = -600\mu\text{A}$	$0.9V_{DD}$	—	—	V	CKO, SYNCB	
"L" output voltage 1	$V_{OL1}$	$I_o = 600\mu\text{A}$	—	—	$0.1V_{DD}$	V	CKO, SYNCB	
"L" output voltage 2	$V_{OL2}$	$I_o = 600\mu\text{A}$	—	—	$0.1V_{DD}$	V	SDAACK	
Driver ON resistor	Segment	$V_{OHS}$	$V_{LCD} = 5$ V	—	5	15	$k\Omega$	SEG1 to SEG160
	Common	$V_{OHC}$	$V_{LCD} = 5$ V	—	5	12	$k\Omega$	COM 1 to COM4

(\*1): DATA(SDA), CLOCK(SCL), LOAD, M/S, SYNCB, Duty1, Duty0, BIAS, SA0, A1, A0, OSC1, OSC I/E, I2C, POCEB

( $V_{DD} = 2.7$  to  $5.5$  V,  $V_{LCD} = 4.5$  to  $5.5$  V,  $T_a = -40$  to  $+105^\circ\text{C}$ )

Item	Symbol	Condition	Min.	Typ.	Max.	Unit	Applicable pin	
Static supply current	$I_{DD5}$	$V_{DD}=V_{LCD}=5.5$ V Input pin fixed to "H" or "L"	—	8	15	$\mu\text{A}$	$V_{DD}$	
	$I_{LCD5}$	Oscillation stopped, output no-load POCEB="L"	—	9	15	$\mu\text{A}$	$V_{LCD}$	
Dynamic supply current 1	$I_{DD1}$	$V_{DD}=V_{LCD}= 5.5$ V (*2)(*3) Clock OSC1 external input	(*6)	—	10	18	$\mu\text{A}$	$V_{DD}$
	$I_{LCD1}$	$f_{CP1}=1.8$ kHz	(*7)	—	9	15	$\mu\text{A}$	$V_{LCD}$
Dynamic supply current 2	$I_{DD2}$	$V_{DD}=V_{LCD}= 5.5$ V (*2)(*3) Internal oscillation	(*6)	—	65	90	$\mu\text{A}$	$V_{DD}$
	$I_{LCD2}$		(*7)	—	9	15	$\mu\text{A}$	$V_{LCD}$
Dynamic supply current 3	$I_{DD3}$	$V_{DD}=V_{LCD}= 5.5$ V (*2)(*4)(*6) Internal oscillation	—	200	300	$\mu\text{A}$	$V_{DD}$	
	$I_{LCD3}$	At three-wire serial IF data input	—	9	15	$\mu\text{A}$	$V_{LCD}$	
Dynamic supply current 4	$I_{DD4}$	$V_{DD}=V_{LCD}= 5.5$ V (*2)(*5)(*6) Internal oscillation	—	230	350	$\mu\text{A}$	$V_{DD}$	
	$I_{LCD4}$	At I <sup>2</sup> C IF data input	—	9	15	$\mu\text{A}$	$V_{LCD}$	

(\*2): M/S = "H", 1/4-duty, 1/3-bias, (F1,F0) = (1,1) 95 Hz, POCEB = "L", output pin no-load.

(\*3): Three-wire serial or I<sup>2</sup>C interface. Input pin fixed to "H" or "L".

(\*4): Serial interface, data input frequency = 1 MHz.

(\*5): I<sup>2</sup>C interface, data input frequency = 400 kHz.

(\*6): Alternately inputs "0" and "1" for LCD display data (checkered display).

(\*7): Inputs all "1s" for LCD display data (all illuminated).

## Switching Characteristics

- OSC timing

( $V_{DD} = 2.7$  to  $5.5$  V,  $V_{LCD} = 4.5$  to  $5.5$  V,  $T_a = -40$  to  $+105^\circ\text{C}$ )

Item	Symbol	Condition	Min.	Typ.	Max.	Unit	Applicable pin
OSC IN clock frequency (external input)	$f_{CP1}$	Clock input from OSC1. OSC2 and OSCR open. OSC I/E = "L"	—	1.8	10	kHz	OSC1
Clock pulse width (External input)	$t_{WCP1}$		40	—	—	$\mu\text{s}$	OSC1
Clock rise and fall time (external input)	$t_{OSC}$		—	—	(*1)	$\mu\text{s}$	OSC1
External Rf clock frequency (Internal oscillation)	$f_{OSC1}$	Between OSC1 and OSC2 $R_f = 470\text{k}\Omega$ (F1,F0)=(0,1) OSCR open. OSC I/E = "H"	18	28.8	44	kHz	OSC1, OSC2
Internal clock frequency (Internal oscillation)	$f_{OSC2}$	OSC1 open. (F1,F0)=(0,1) OSC2 and OSCR short-circuited. OSC I/E = "H"	18	28.8	44	kHz	OSC1, OSCR, OSC2

The relation between OSC IN clock frequency and frame frequency is as the equation below.

$$f_{FRM} = f_{OSC} / 24$$

(\*1)  $t_{OSC}$  is a reference value.

The longer the clock rise and fall time, the more susceptible to extraneous noises around the threshold value.  
Make the rise as steep as possible. Reference value: max=2 $\mu\text{s}$ .

- Serial interface timing

( $V_{DD} = 2.7$  to  $5.5$  V,  $V_{LCD} = 4.5$  to  $5.5$  V,  $T_a = -40$  to  $+105^\circ\text{C}$ )

Item	Symbol	Condition	Min.	Typ.	Max.	Unit	Applicable pin
Data clock frequency	$f_{CP2}$		—	—	1	MHz	CLOCK
Data clock pulse width	$t_{WCP2}$		100	—	—	ns	CLOCK
Data setup time	$t_{SU}$		50	—	—	ns	DATA
Data hold time	$t_{HD}$		50	—	—	ns	CLOCK
CLOCK-LOAD timing	$t_{CL}$		100	—	—	ns	CLOCK
LOAD-CLOCK timing	$t_{LC}$		100	—	—	ns	LOAD
LOAD pulse width	$t_{WLD}$		100	—	—	ns	LOAD
Signal rise and fall time	$t_{sr}, t_{sf}$		—	—	(*2)	ns	CLOCK, DATA, LOAD

(\*2)  $t_{sr}$  and  $t_{sf}$  shall be reference values.

The longer the clock rise and fall time, the more susceptible to extraneous noises around the threshold value.  
Make the rise as steep as possible. Reference value: max=10ns.

- I<sup>2</sup>C interface timing

(V<sub>DD</sub> = 2.7 to 5.5 V, V<sub>LCD</sub> = 4.5 to 5.5 V, Ta = -40 to +105°C)

Item	Symbol	Condition	Min.	Typ.	Max.	Unit	Applicable pin
SCL clock frequency	f <sub>SCL</sub>		—	—	400	kHz	SCL
Hold time (repeat) "STATRT" condition	t <sub>HD,STA</sub>		0.6	—	—	μs	SCL,SDA
SCL "L" pulse width	t <sub>LOW</sub>		1.3	—	—	μs	SCL
SCL "H" pulse width	t <sub>HIGH</sub>		0.6	—	—	μs	SCL
Setup time for repeat "START" condition	t <sub>SU,STA</sub>		0.6	—	—	μs	SCL,SDA
Data hold time	t <sub>HD,DAT</sub>		0	—	—	ns	SCL,SDA
Data setup time	t <sub>SU,DAT</sub>		200	—	—	ns	SCL,SDA
Setup time for "STOP" condition	t <sub>SU,STO</sub>		0.6	—	—	μs	SCL,SDA
Bus free time between "STOP" condition and "START" condition	t <sub>BUF</sub>		1.3	—	—	μs	SCL
Data valid acknowledge time	t <sub>VD,ACK</sub>		—	—	1.2	μs	SCL,SDAAACK
Signal rise and fall time	t <sub>ir,tif</sub>		—	—	(*3)	μs	SCL,SDA
Data bus load capacitance	C <sub>b</sub>		—	—	400	pF	SDA,SDAAACK
Noise pulse width tolerance	t <sub>wf</sub>		—	—	50	ns	SCL,SDA

(\*3) t<sub>ir</sub> and t<sub>tif</sub> shall be reference values.

The longer the clock rise and fall time, the more susceptible to extraneous noises around the threshold value.  
Make the rise as steep as possible. Reference value: max=0.1us.

**Timing chart (OSC1)**

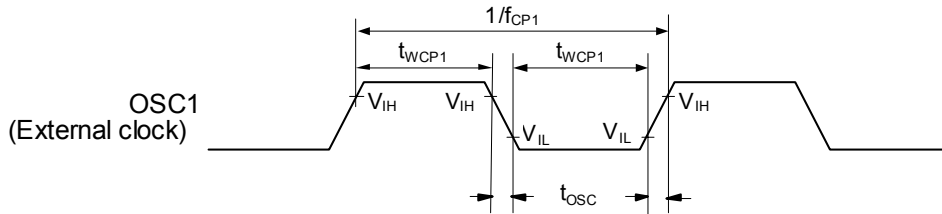

**Timing chart (Serial interface)**

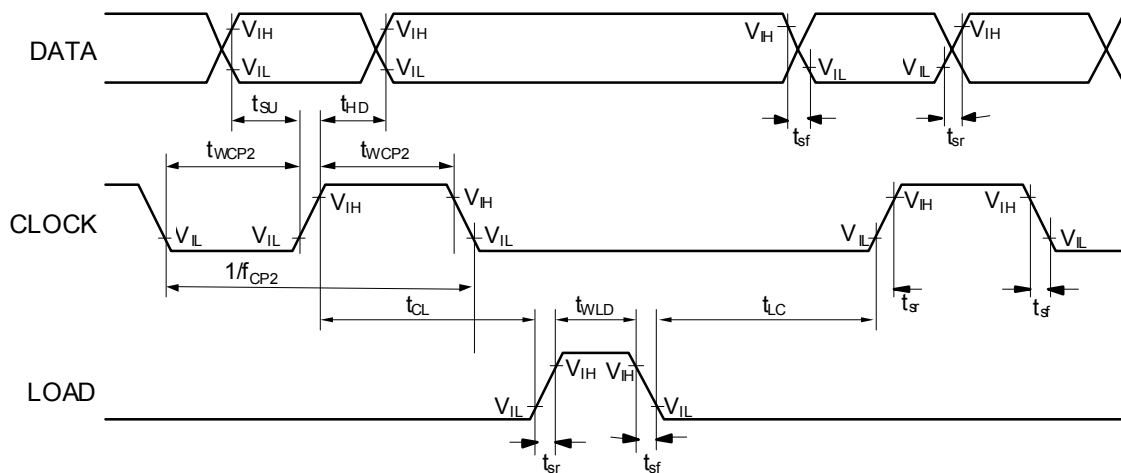

**Timing chart (I<sup>2</sup>C interface)**

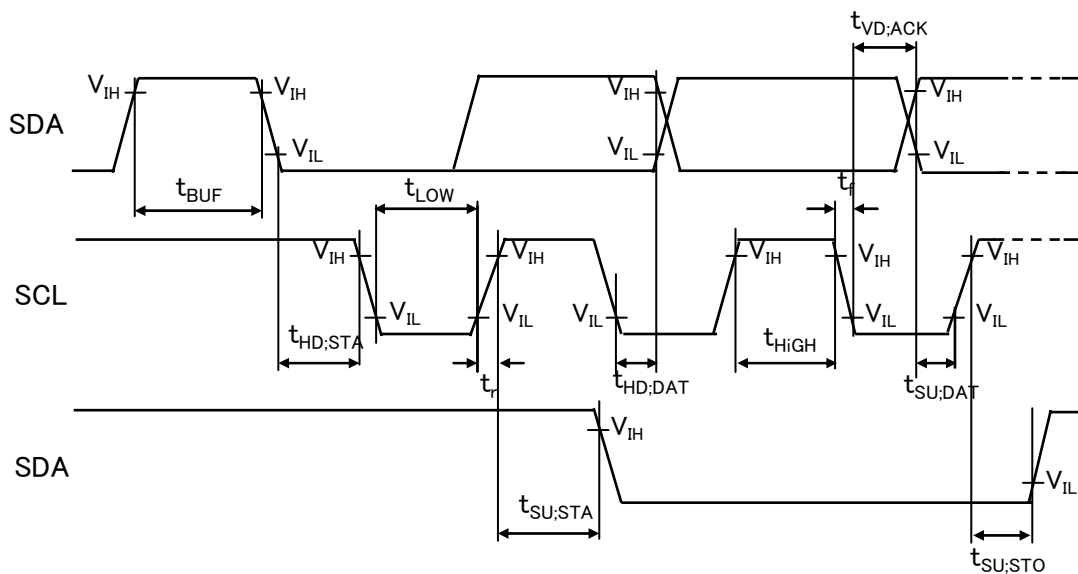

**REFERENCE DATA**

Frame frequency Characteristics

VDD=5.5V/2.7V Rf=470Ω

Frame frequency  $f_{FRM} = f_{OSC} / (16 \times 24)$

fosc = 1 / (Device coefficient x External resistor Rf)

Device coefficient =  $73.8 \times 10^{-12} \pm 25\%$

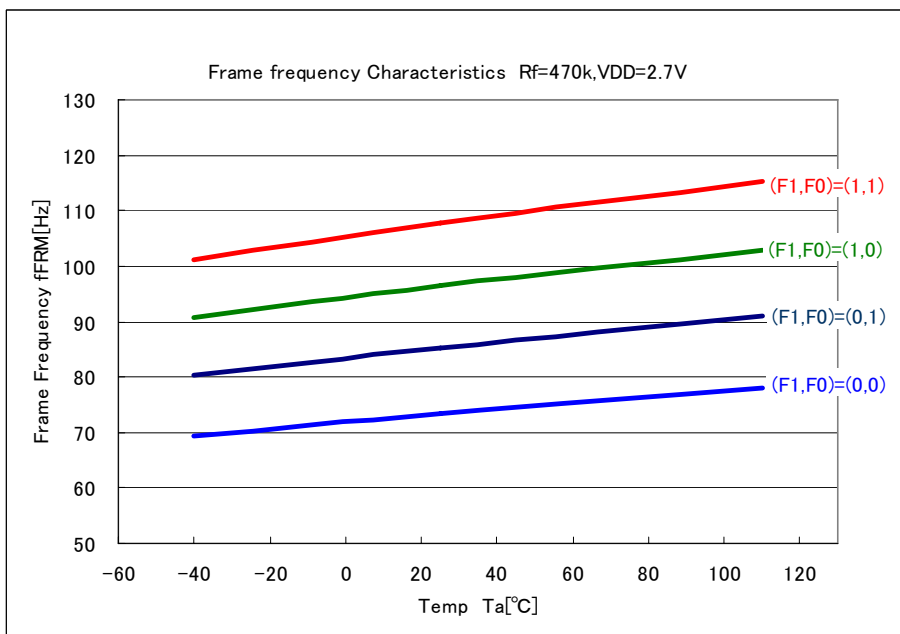
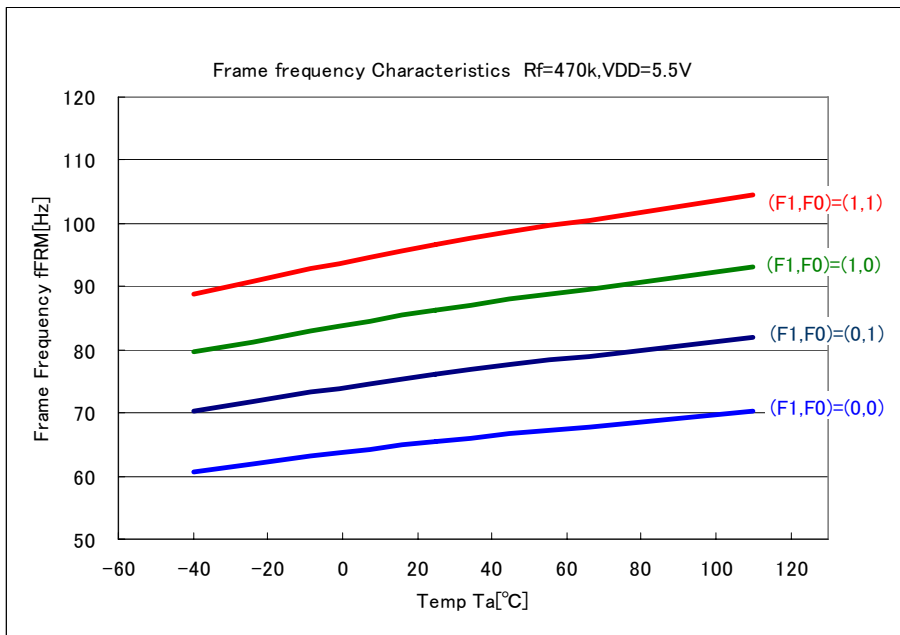

## POWER ON/OFF TIMING

To turn on the power supply, raise the logic power supply first, then LCD drive power supply in order to prevent the IC from malfunctioning.

To fall the power supply, fall the LCD drive power supply first, then the logic power supply.

For a VDD pin ranging from 0 V to VDDmin, set  $VDD \geq VLCD$  and  $t1 \geq 0$  [ns].

To enable the Internal POC circuit, the VDD power supply rise time  $t2$  range needs to be  $100 [\mu s] \leq t2 \leq 500$  [ms].

For the VDD power supply to turn OFF then turn ON again, it is necessary to secure the POC discharge time  $t3 \geq 100$  [ms].

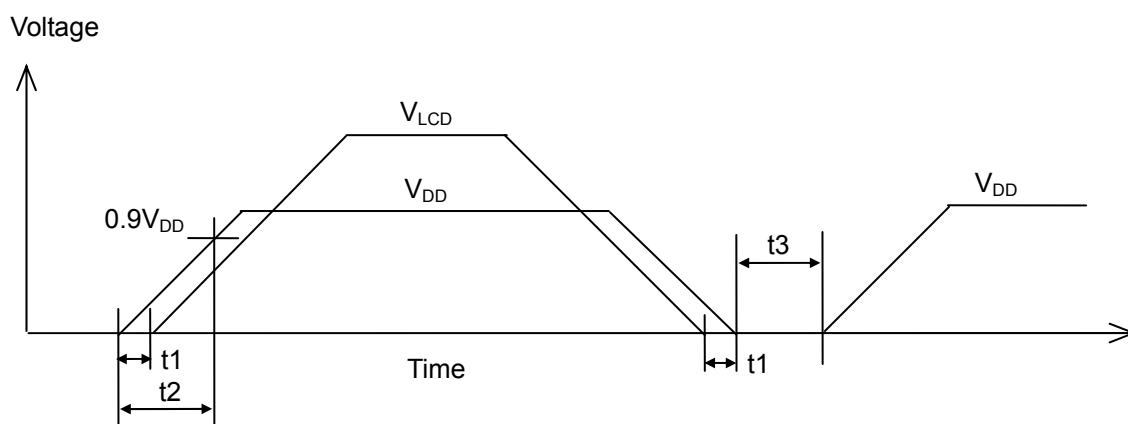

## INITIALIZATION SIGNAL TIMING

### When RESETB signal is externally input

The RESETB pin input is valid both for POCEB = "L" and "H". Usable in combination with the POC. Keep the RESETB pin at "L" level until the VDD reaches VDDmin. ( $t4 \geq 200$ [ns])

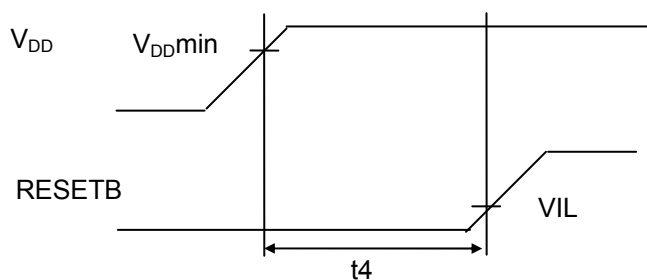

### When Internal POC circuit is used

When using the Internal POC circuit in the initialization, set the POCEB pin to "L".

At this time, the power ON/OFF timing conditions are t1 to t3 above mentioned.

### When RESETB pin POC circuit is used

If the power ON/OFF timing conditions t1 to t3 cannot be kept, the RESETB pin needs to have a capacitance to configure the POC circuit. For this case, connect a capacitance value according to the power supply rise time.

For the power supply rise time  $t2$  and external capacitance value, use the following formula as a guide:

$$C_{RST} [F] > t2 [sec] / (30 \times 10^3)$$

## PIN DESCRIPTIONS

Pad number	Symbol	I/O	Description
109-112	M/S	I	This is the input to switch between the master and slave modes. It has a schmitt circuit. When this pin is "H", the mode is master. When this pin is "L", the mode is slave.
9-12 13-16	Duty0 Duty1 *1	I	Display duty switch pin. It has a schmitt circuit. Duty0="0", Duty1="0" : Static (COM1=COM2=COM3=COM4) Duty0="1", Duty1="0" : 1/2Duty (COM1=COM3, COM2=COM4) Duty0="0", Duty1="1" : 1/3Duty (COM2=COM4) Duty0="1", Duty1="1" : 1/4Duty
121-124	BIAS	I	This pin sets the LCD bias. It has a schmitt circuit. BIAS="0": 1/3bias BIAS="1": 1/2bias
25-28	SA0	I	Slave address input pin. It has a schmitt circuit.
17-20 21-24	A1 A0	I	Sub address input pin. It has a schmitt circuit.
117-120	OSC I/E	I	This input selects whether to use the external clock input mode or to use the Internal oscillation mode or external oscillation mode. It has a schmitt circuit. When this pin is "H", the mode is the Internal or external Rf oscillation mode. When this pin is "L", the mode is the external clock input mode. Use the slave chip as it is connected to GND.
78-82 83-87 88-82	OSC1, OSCR, OSC2 *2	I I O	This pin is for the oscillator circuit to generate common signals. The OSC1 and OSC2 pins are input pins and have a schmitt circuit. OSC2 is an output pin. It becomes an output when the OSC I/E pin = "H" and a high impedance when the OSC I/E pin = "L". 【 In the master mode (M/S pin = "H") 】 Three types are selectable: Internal oscillation mode, external oscillation mode, and external clock input mode. •Internal oscillation mode: Set the OSC I/E pin to "H", short the OSC2 and OSC2 pins, and open the OSC1 pin. •External Rf oscillation mode: Set the OSC I/E pin to "H", connect an oscillation resistor Rf between the OSC1 and OSC2 pins, and open the OSC2 pin. •External clock input mode: Set the OSC I/E pin to "L", open the OSC2 and OSC2 pins, and input the external clock to the OSC1 pin. 【 In the slave mode (M/S pin = "L") 】 Open the OSC2 and OSC2 pins and connect the OSC1 pin to the ML9479B's CKO pin that has been set to the master mode.
93-97	CKO	O	Clock output pin. In the master mode (M/S pin = "H"), the 1/16 division signal of the oscillation frequency is output. In the slave mode (M/S pin = "L"), the output is fixed to "L". For a cascade connection, connect this pin to the OSC1 pin of the chip that has been set to the slave mode.

**ML9479B**

98-102	SYNCB	I/O	Input/output pin for common synchronization. It has a schmitt circuit. It becomes the synchronization signal output pin in the master mode (M/S pin = "H"). It becomes the synchronization signal input pin in the slave mode (M/S pin = "L"). For cascade connection, connect all of the involved ML9479Bs' SYNC pins by the common line.
105-108	I2C	I	Interface switching pin. It has a schmitt circuit. When this pin is "H", the interface is I <sup>2</sup> C. When this pin is "L", the interface is three-wire serial.
36-40	DATA (SDA)	I	Display data input pin. It has a schmitt circuit. I2C="L": Serial interface; DATA Input the display data in the order of SEG160, SEG159, ... , SEG2, and SEG1. The display data turns on at "H" and turns off at "L". I2C="H": I <sup>2</sup> C interface; SDA Input the display data in units of 8 bits. The display data turns on at "H" and turns off at "L". This pin has a built-in noise filter through which noises in widths up to 50 ns are removed. This noise filter is valid only when I2C = "H".
41-45	CLOCK (SCL)	I	Shift clock input pin for display data. It has a schmitt circuit. I2C="L": Serial interface; CLOCK The display data input to the DATA pin is serially input to the shift register at the CLOCK signal rise. I2C="H": I <sup>2</sup> C interface; SCL The display data input to the SDA pin is serially input to the shift register at the SCL signal rise. This pin has a built-in noise filter through which noises in widths up to 50 ns are removed. This noise filter is valid only when I2C = "H".
46-50	LOAD	I	Input pin for the load signal of display data. It has a schmitt circuit. I2C="L": Serial interface; LOAD The display data in the shift register is transmitted as is to the segment driver for the "H" duration. When this pin is brought into "L", the shift register is disconnected from the segment driver. The display data in the shift register immediately before it become "L" is held in the data latch and transmitted to the segment driver. I2C="H": I <sup>2</sup> C interface Use this pin as it is connected to GND.
31-35	SDAACK	O	I2C="L": Serial interface Use this pin as it is opened. I2C="H": I <sup>2</sup> C interface The I <sup>2</sup> C bus acknowledge output signal. Normally, use it as it is connected with the SDA pin. Connect an external pull-up resistor whenever necessary, as it is an open drain pin. The pull-up connection destination supply voltage shall be the V <sub>DD</sub> supply voltage or less.
113-116	POCEB	I	Internal POC circuit enable pin. It has a schmitt circuit. When this pin is "H", the POC circuit becomes OFF and the constant current (8μA) is cut. The RESETB pin pull-up resistor is cut as well. When this pin is "L", the POC circuit becomes ON. The RESETB pin is connected to a pull-up resistor.
73-77	RESETB *3	I	Reset signal input pin for initializing inside the IC. It has a schmitt circuit. The "L" level enables the reset. This pin has a Internal pull-up resistor. Open when POCEB = "H". Pull-up when POCEB = "L". The power-on reset operation is available by connecting an external capacitor.

125-128 129-132	TEST1 TEST2	I	Pin for testing the IC. It has a Internal pull-down resistor. Use it as it is connected to GND.
155-234 239-318	SEG1 ~SEG160	O	Output for LCD display. Connected to the segment pin on the LCD panel.
143-146 235-238 326-329	COM1 ~COM4	O	Output for LCD display. Connected to the common pin on the LCD panel. The output pin is located at three positions: both ends of the chip and between SEG80 and SEG81. Each is connected inside the chip. Use the COM pin in accordance with the panel to be used.
59-65	VDD	-	Power supply pin for logic circuit.
66-72	VLCD	-	Power supply pin for LCD driver.
51-58	GND	-	Ground pin.
29-30 103-104	VDDO	-	VDD output pin. Use this pin when fixing the mode setting input pin to "H" on the COG.
7-8 133-134	GNDO	-	Ground output pin. Use this pin when fixing the mode setting input pin to "L" on the COG.
1-6 135-142 147-154 319-325 330-331	DUMMY	-	Floating pin. At this time, avoid this pin from shorting with pins other than DUMMY in the wiring on the COG.

\*1: For details of the COM waveform when a duty is selected, refer to "Common waveform" on page 18.

\*2: Oscillator circuit configuration

- When M/S = "H", OSC I/E = "H"

[Internal Rf oscillation mode]

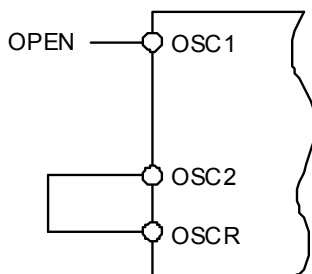

[External Rf oscillation mode]

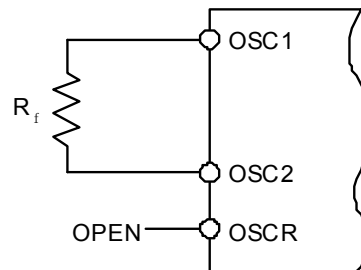

- External clock input mode when M/S = "H" and OSC I/E = "L"

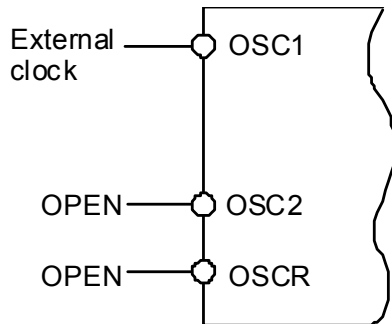

- M/S = "L", slave mode, external clock input mode

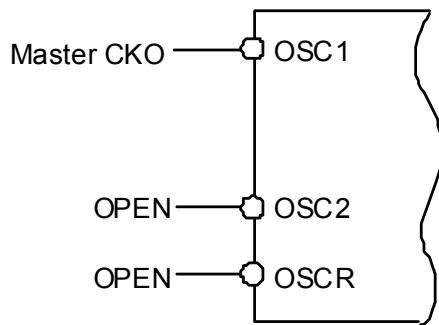

\*3: Reset circuit configuration

- External input to RESTB when POCEB = "H"

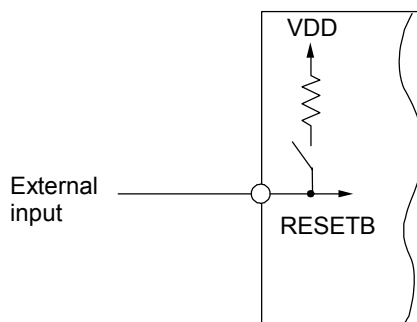

- POC circuit configuration when POCEB = "L"

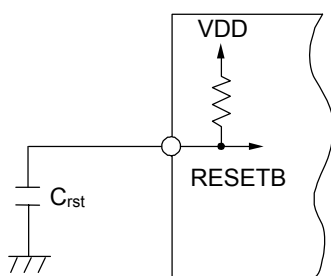

## DESCRIPTION

### Operation description (Serial interface)

- Display data input

As described in the Data configuration section, the display data consists of the data field that corresponds to each segment on/off and the command field that indicates the display data input.

When inputting the display data, the "F3" command is set in the command field. When the "F1" or "F2" command is set in the command field, the display data in the data field becomes invalid.

The data input to the DATA pin is loaded to the shift register at the CLOCK pulse rise, transferred to the display data latch during the LOAD pulse at the "H" level, then output via the segment driver.

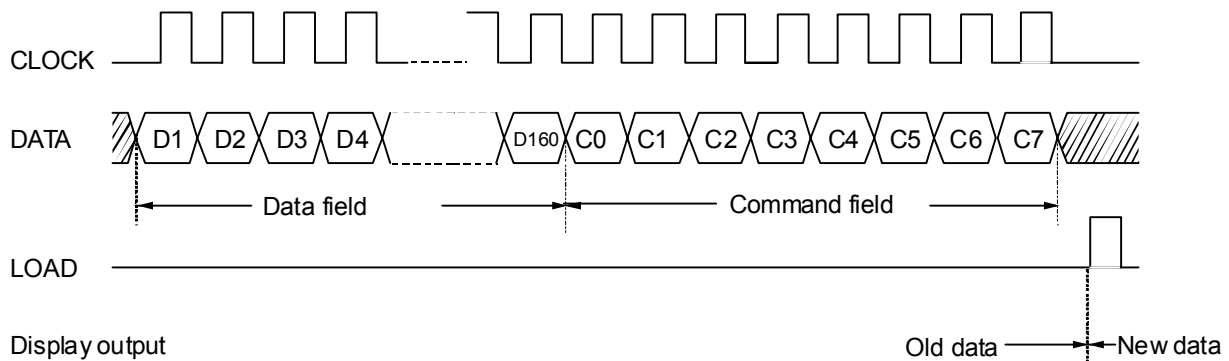

- Display on, Display off

The display becomes off at power-on reset. To display, write the display on command.

The display off is the command that makes all segments off. Writing the display off command turns off the lights regardless of the display data.

The display on is the command to release the display off. Writing the display on command returns the display to the original state.

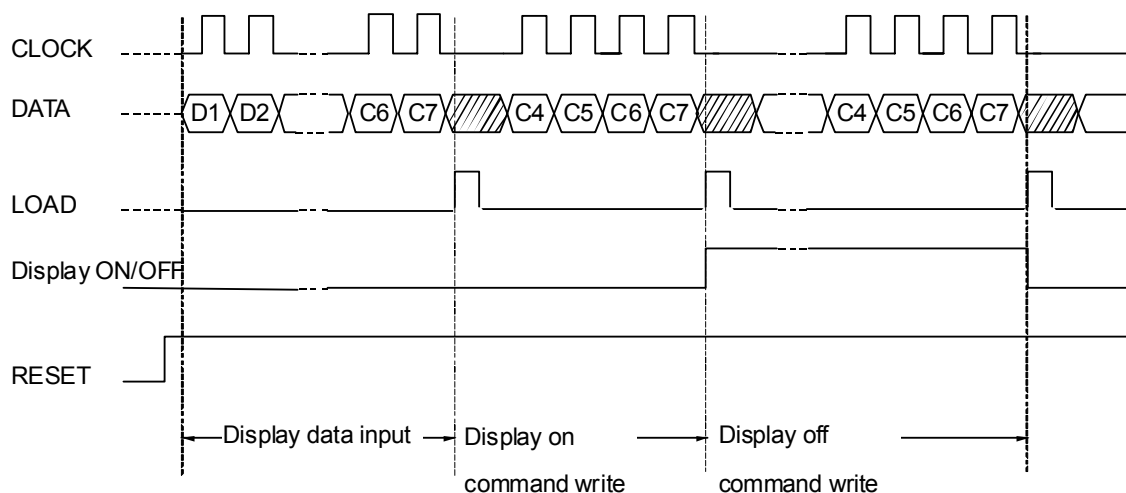

**List of Commands**

Command name	C7	C6	C5	C4	C3	C2	C1	C0	Operation
F0	0	0	0	0	x	x	x	x	Disabled
F1	0	1	F1 (*2)	F0 (*2)	x	x	x	x	Frame frequency setting (F1,F0)=(0, 0): 65Hz (F1,F0)=(0, 1): 75Hz (F1,F0)=(1, 0): 85Hz (F1,F0)=(1, 1): 95Hz (valid for Internal CR oscillation)
F2	1	0	1	D (*2)	x	x	x	x	Display on/off "0": Off "1": On
F3(*1)	1	1	SA1	SA0	A1	A0	Co1	Co0	Data write address setting (Co1,Co0)=(0, 0): Corresponding to common 1 (Co1,Co0)=(0, 1): Corresponding to common 2 (Co1,Co0)=(1, 0): Corresponding to common 3 (Co1,Co0)=(1, 1): Corresponding to common 4 SA1, SA0, A1, A0: Chip address

x: Don't care

(\*1): For the I<sup>2</sup>C interface, SA0 is set at a slave address.  
These bits become "Don't care".

In the ML9479B, set the SA1 address to "1".

(\*2): The register is set to the following value by the RESETB = "L" input or by the power-on POC.  
F1="0", F0="0", D="0"

**Data configuration**

- Data configuration (Serial interface)

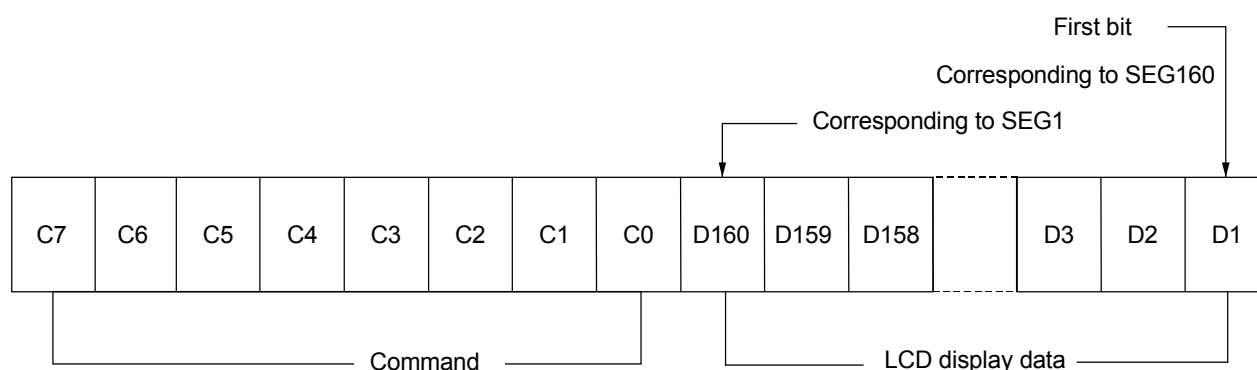

Note 1 : The commands F1 and F2 settings become valid when the least four bits of C4 to C7 are input.  
(The bits from D1 to D160 and from C0 to C3 are not necessary.)

Note 2 : If the dummy bit is needed for the reason of number of transfer bits, put it on the first bit side.

Note 3 : The command execution follows the contents of the C7 to C0 registers immediately before the LOAD becomes "H".

• Data configuration (I<sup>2</sup>C interface)

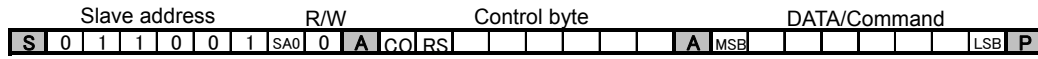

Slave address: 0 1 1 0 0 1

CO: Consecutive control byte setting bit  
 0: Last control byte, 1: Consecutive control byte  
 RS: Command/data setting bit  
 0: Command data, 1: Display data

For the I<sup>2</sup>C interface, each IC is assigned with a 7-bit slave address. The first one byte in the transfer consists of this 7-bit slave address and the R/W bit that indicates the data transfer direction. Always input "0" to the eighth R/W bit because the ML9479B is a write-only LSI.

The eight bits next to the slave address is a control byte. The first one bit is CO: consecutive command setting bit and the next one bit is RS: command/data setting bit (the remaining six bits are the Don't care bits).

When CO = "0": Means the last control byte.

When CO = "1": Means the control bytes are successively input.

When RS = "0": Means the data to be input next is the command data.

When RS = "1": Means the data to be input next is the display data.

The display data can be successively input.

Example of Data Setting

- When inputting two commands

When inputting two commands

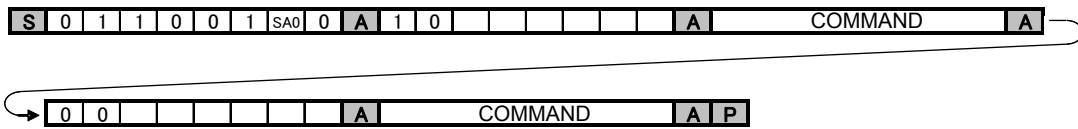

- When inputting the command and display data

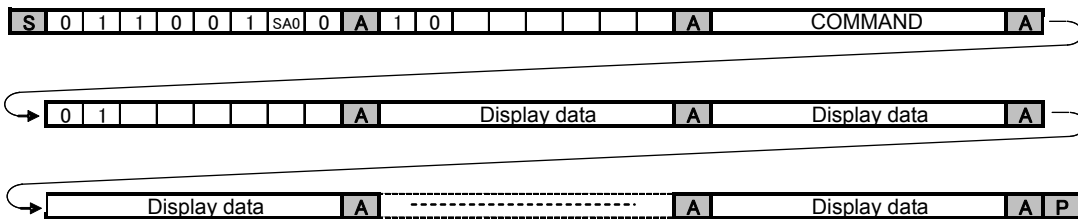

**Data write method**

• Serial interface

The data is written to the address set by the data write setting command (F3).

For the Serial interface, the data is written in units of 160 bits.

Written from D160 to SEG1, D159 to SEG2, ... , D2 to SEG159, and D1 to SEG160.

	MSB				Segment output								LSB
	1	2	3	4	72	73	74	75	76	77	78	79	
COM1	D160	D159	D158	D157	D89	D88	D87	D86	D85	D84	D83	D82	D81
COM2	D160	D159	D158	D157	D89	D88	D87	D86	D85	D84	D83	D82	D81
COM3	D160	D159	D158	D157	D89	D88	D87	D86	D85	D84	D83	D82	D81
COM4	D160	D159	D158	D157	D89	D88	D87	D86	D85	D84	D83	D82	D81

	MSB				Segment output								LSB
	81	82	83	84	152	153	154	155	156	157	158	159	
COM1	D80	D79	D78	D77	D9	D8	D7	D6	D5	D4	D3	D2	D1
COM2	D80	D79	D78	D77	D9	D8	D7	D6	D5	D4	D3	D2	D1
COM3	D80	D79	D78	D77	D9	D8	D7	D6	D5	D4	D3	D2	D1
COM4	D80	D79	D78	D77	D9	D8	D7	D6	D5	D4	D3	D2	D1

• I<sup>2</sup>C interface

The data is written to the address set by the slave address.

For the I<sup>2</sup>C interface, the data is written to the specified address starting with the LSB side in units of 8 bits.

(The data is written in the order from SEG153-160, SEG145-SEG152, ... , SEG9-16, and SEG1-SEG8.)

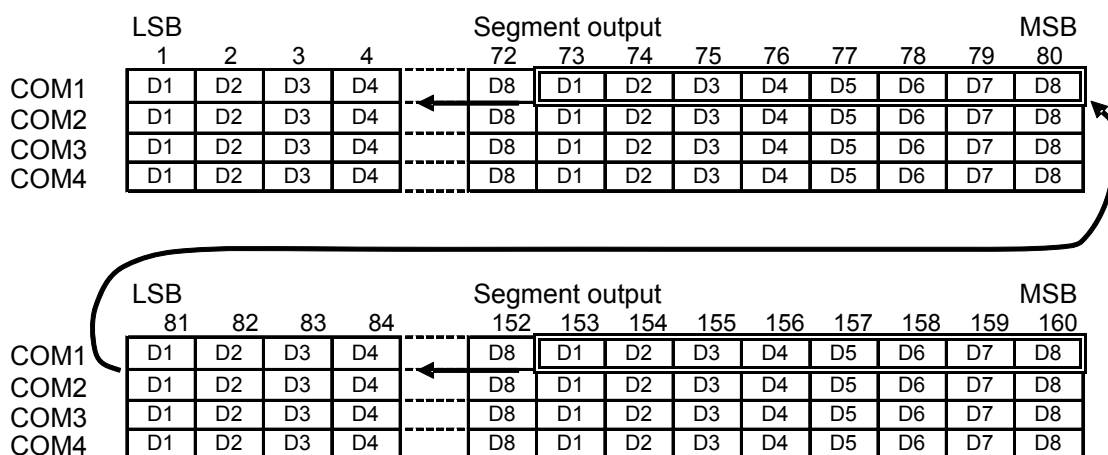

● Common waveform

(1) At static

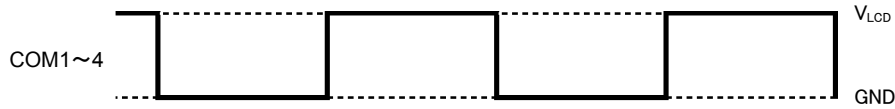

(2) At 1/2-duty  
At 1/2-bias

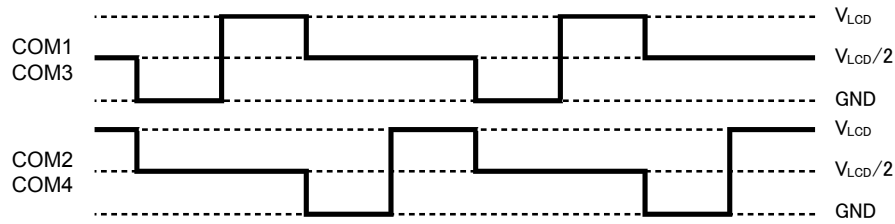

At 1/3-bias

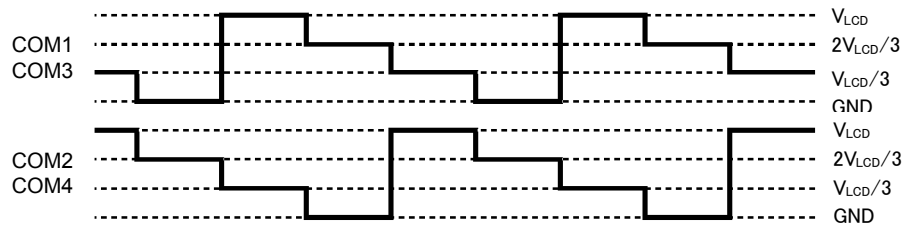

(3) At 1/3-duty

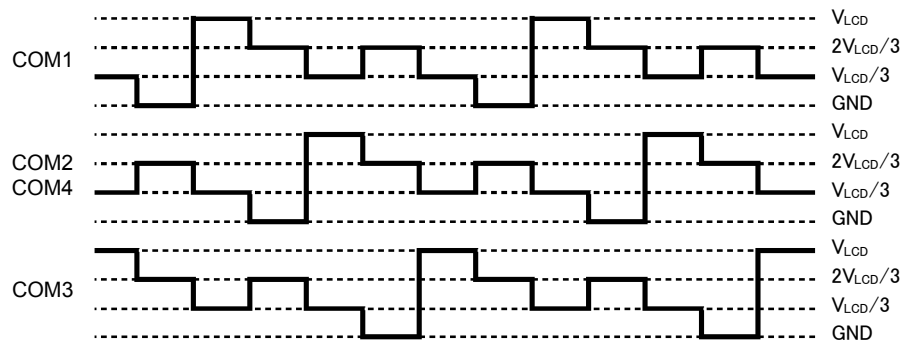

(4) At 1/4-duty

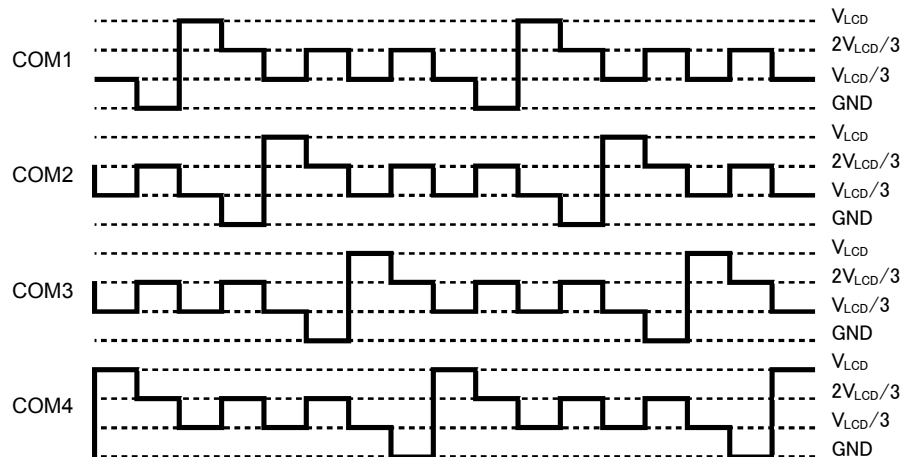

- Common segment output waveform  
 · At 1/3-duty

Display example

	S	S	S
	E	E	E
	G	G	G
	1	2	3

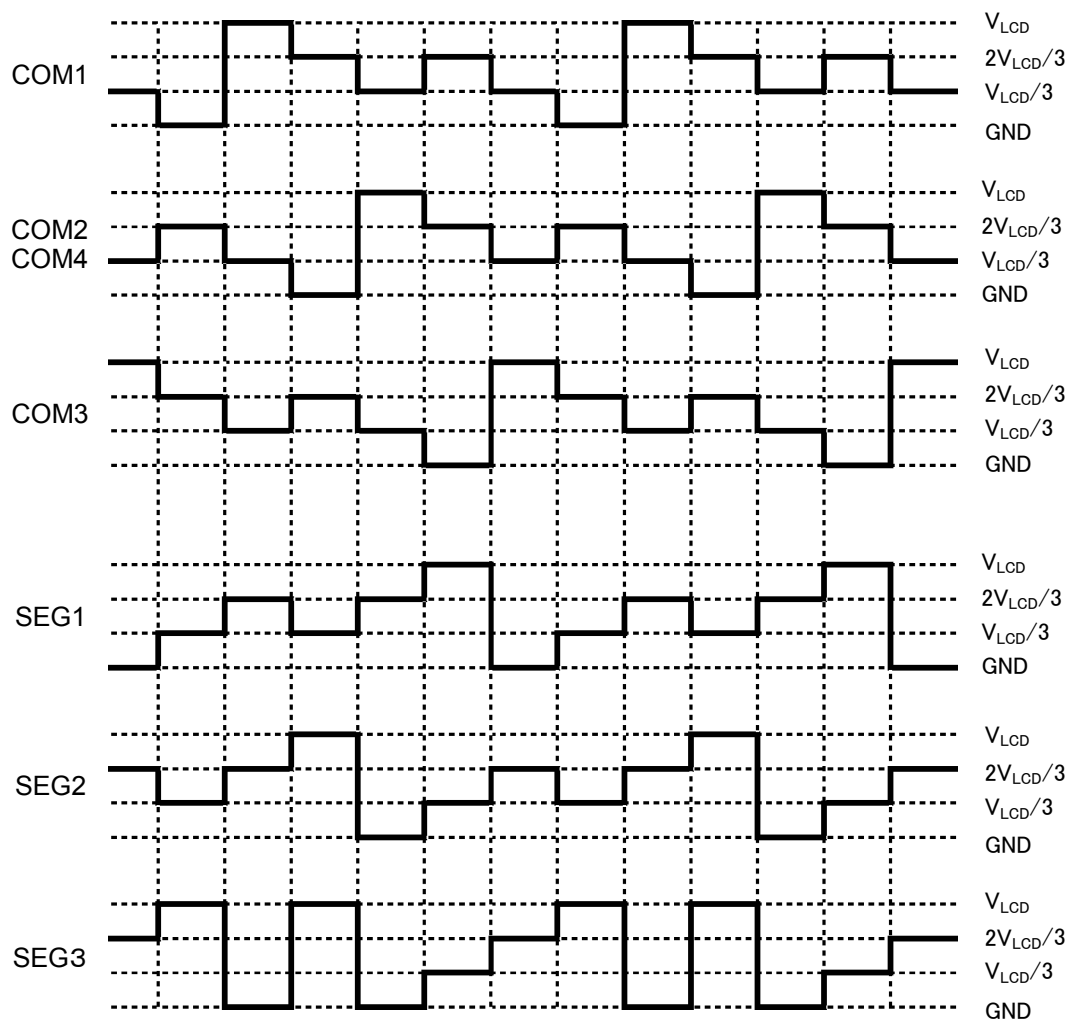
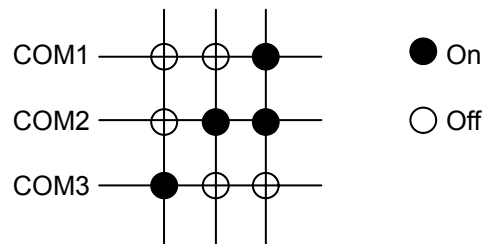

- Common segment output waveform  
 · At 1/4-duty

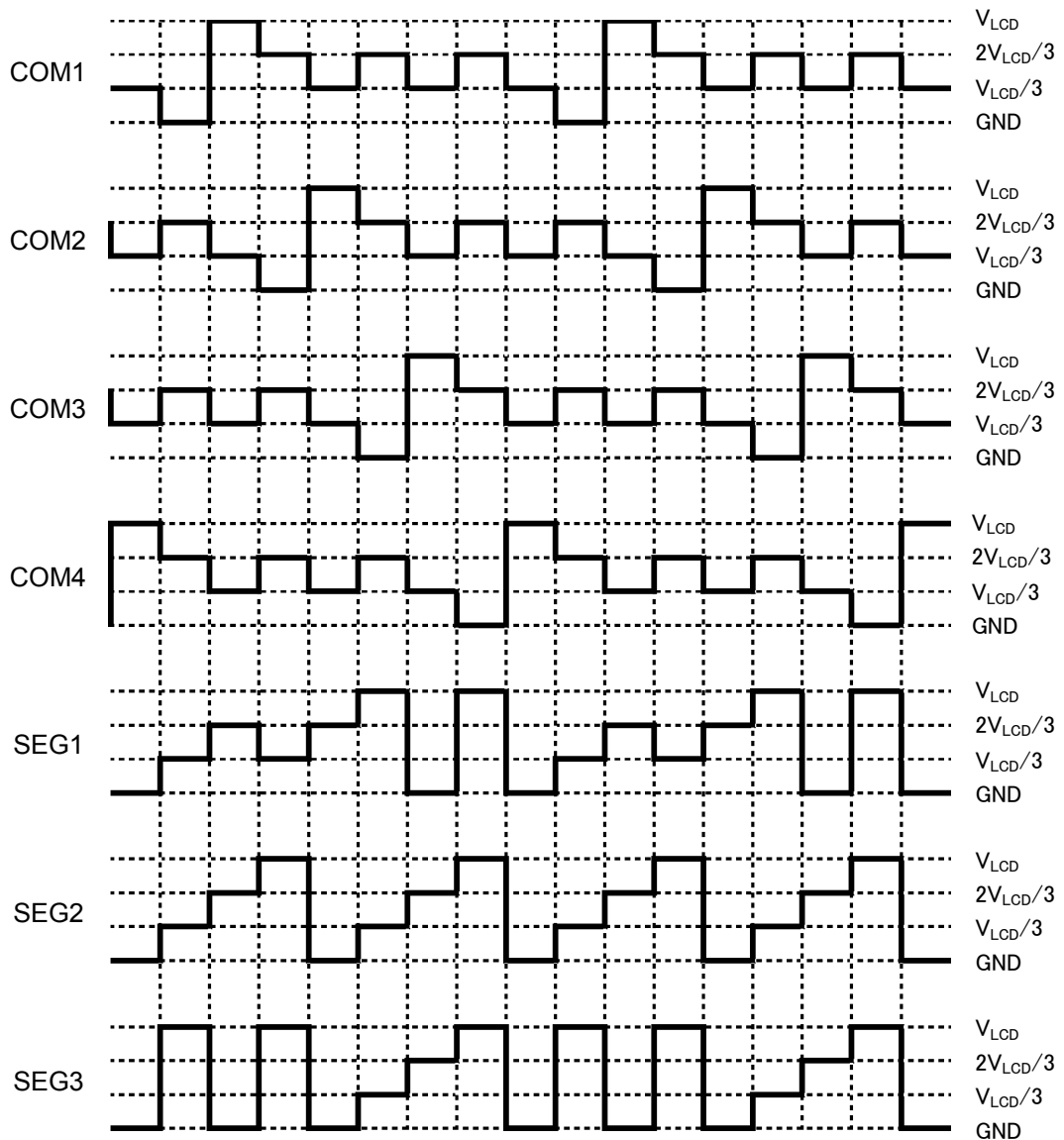
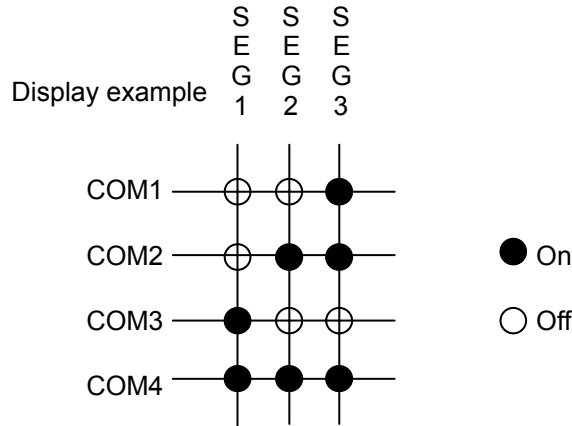

**EXAMPLE OF APPLICATION CIRCUIT**

**Cascade configuration 1**

- Serial interface
- Internal CR oscillator circuit used
- 1/4Duty
- RESETB pin + external capacitance connection to configure POC circuit

[External component]

- $C_p = 0.1 \text{ } [\mu\text{F}]$  (bypass capacitor between power supplies)
- $C_{rst} = 4.7 \text{ } [\mu\text{F}]$  (capacitance for external POC circuit)

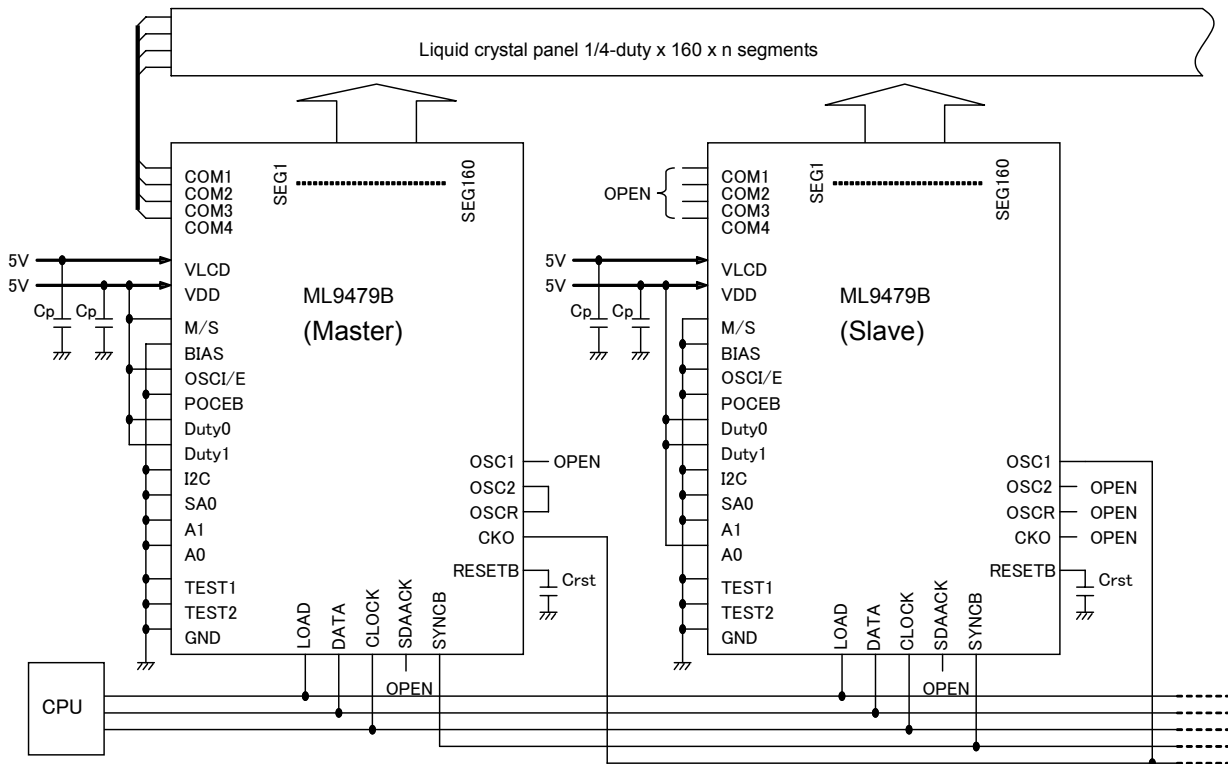

**Cascade configuration 2**

- I<sup>2</sup>C interface
- External R<sub>f</sub>-based CR oscillator circuit used
- 1/4Duty
- External RESETB signal input

[External component]

- C<sub>p</sub> = 0.1 [μF] (bypass capacitor between power supplies),
- R<sub>f</sub> = 470 [kΩ] (external R, resistor for CR oscillator circuit),
- R<sub>up</sub> = Resistor for SDA data bus pull-up

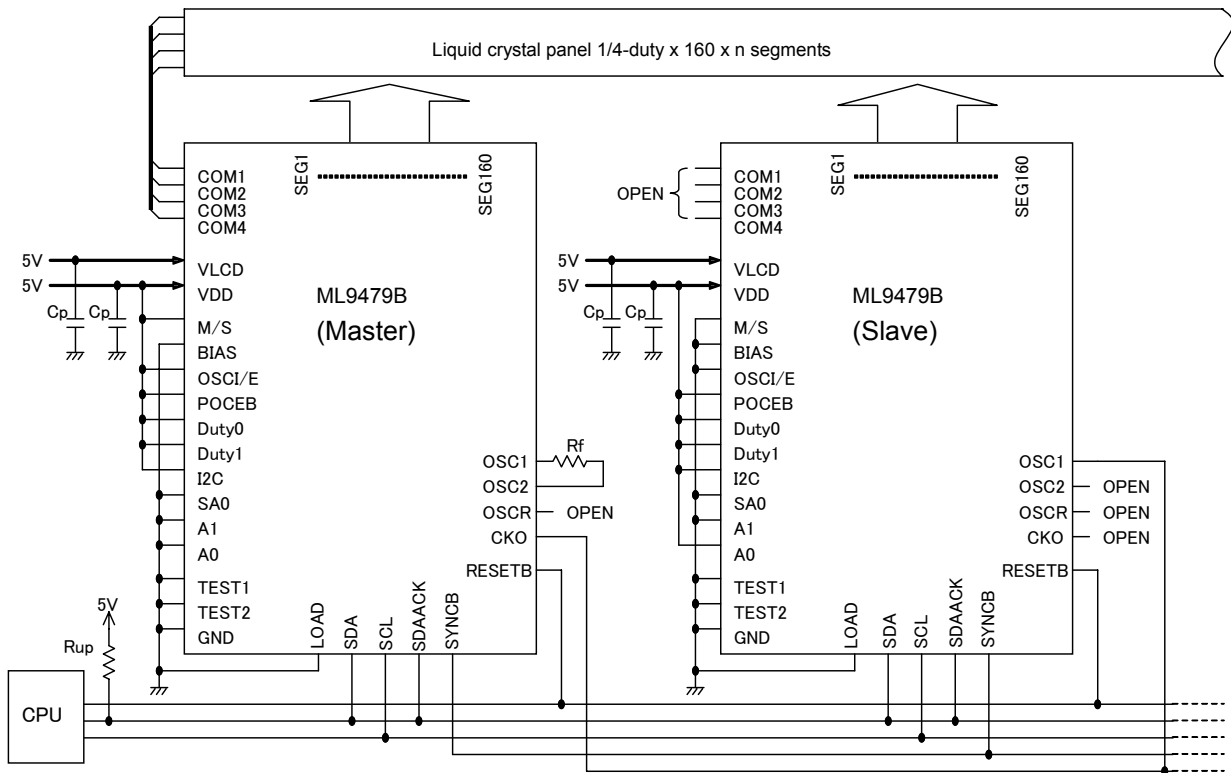

**PAD CONFIGURATION**

**Pad layout (pattern face)**

Chip size : 8.84 mm x 0.90 mm  
 Chip thickness : 400 μm ± 20 μm  
 Minimum bump pitch : 50 μm  
 Bump height : 15 μm ± 3 μm

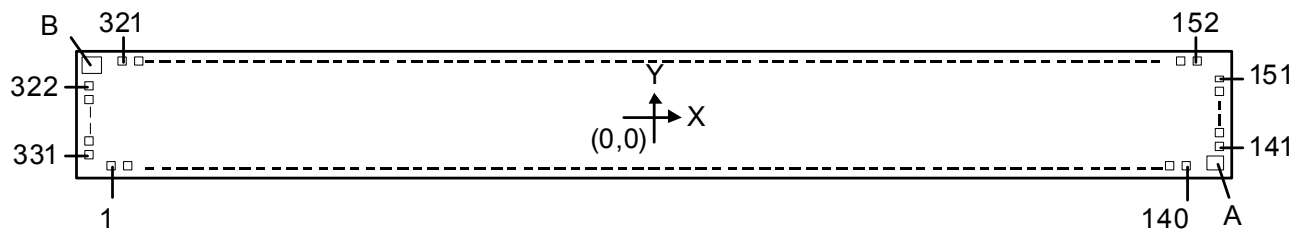

**Bump and alignment mark dimensions (pattern face)**

PAD No.1~140 : 35 μm x 72 μm  
 PAD No.141~331 : 30 μm x 84 μm  
 Alignment marks A and B : See below

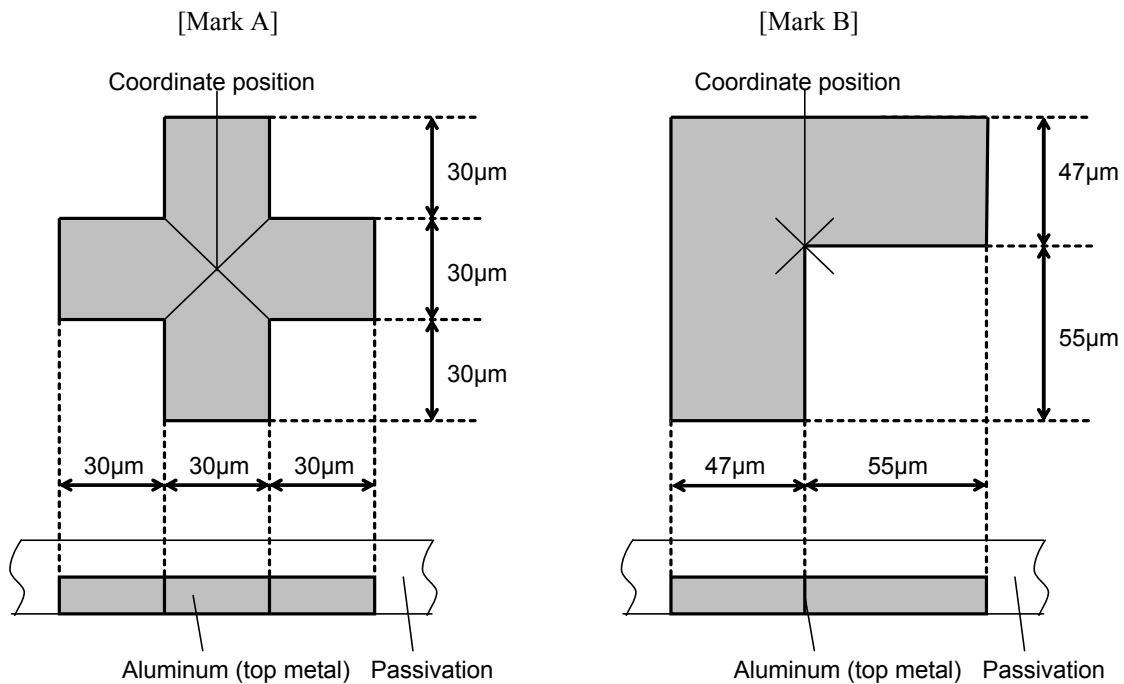

**Pad center coordinates**

Pad number	Pad name	X-coordinate (μm)	Y-coordinate (μm)	Pad number	Pad name	X-coordinate (μm)	Y-coordinate (μm)
1	DUMMY	-4236.2	-312.1	40	DATA(SDA)	-1863	-312.1
2	DUMMY	-4176.2	-312.1	41	CLOCK(SCL)	-1767.8	-312.1
3	DUMMY	-4116.2	-312.1	42	CLOCK(SCL)	-1711.8	-312.1
4	DUMMY	-4056.2	-312.1	43	CLOCK(SCL)	-1655.8	-312.1
5	DUMMY	-3996.2	-312.1	44	CLOCK(SCL)	-1599.8	-312.1
6	DUMMY	-3936.2	-312.1	45	CLOCK(SCL)	-1543.8	-312.1
7	GNDO	-3871	-312.1	46	LOAD	-1448.6	-312.1
8	GNDO	-3815	-312.1	47	LOAD	-1392.6	-312.1
9	Duty1	-3749	-312.1	48	LOAD	-1336.6	-312.1
10	Duty1	-3693	-312.1	49	LOAD	-1280.6	-312.1
11	Duty1	-3637	-312.1	50	LOAD	-1224.6	-312.1
12	Duty1	-3581	-312.1	51	GND	-1154.4	-312.1
13	Duty0	-3510.4	-312.1	52	GND	-1084.2	-312.1
14	Duty0	-3454.4	-312.1	53	GND	-1028.2	-312.1
15	Duty0	-3398.4	-312.1	54	GND	-972.2	-312.1
16	Duty0	-3342.4	-312.1	55	GND	-916.2	-312.1
17	A0	-3272	-312.1	56	GND	-860.2	-312.1
18	A0	-3216	-312.1	57	GND	-804.2	-312.1
19	A0	-3160	-312.1	58	GND	-748.2	-312.1
20	A0	-3104	-312.1	59	VDD	-653	-312.1
21	A1	-3033.8	-312.1	60	VDD	-597	-312.1
22	A1	-2977.8	-312.1	61	VDD	-541	-312.1
23	A1	-2921.8	-312.1	62	VDD	-485	-312.1
24	A1	-2865.8	-312.1	63	VDD	-429	-312.1
25	SA0	-2795.6	-312.1	64	VDD	-373	-312.1
26	SA0	-2739.6	-312.1	65	VDD	-317	-312.1
27	SA0	-2683.6	-312.1	66	VLCD	-221.8	-312.1
28	SA0	-2627.6	-312.1	67	VLCD	-165.8	-312.1
29	VDDO	-2557.4	-312.1	68	VLCD	-109.8	-312.1
30	VDDO	-2501.4	-312.1	69	VLCD	-53.8	-312.1
31	SDAACK	-2406.2	-312.1	70	VLCD	2.2	-312.1
32	SDAACK	-2350.2	-312.1	71	VLCD	58.2	-312.1
33	SDAACK	-2294.2	-312.1	72	VLCD	114.2	-312.1
34	SDAACK	-2238.2	-312.1	73	RESETB	209.6	-312.1
35	SDAACK	-2182.2	-312.1	74	RESETB	265.6	-312.1
36	DATA(SDA)	-2087	-312.1	75	RESETB	321.6	-312.1
37	DATA(SDA)	-2031	-312.1	76	RESETB	377.6	-312.1
38	DATA(SDA)	-1975	-312.1	77	RESETB	433.6	-312.1
39	DATA(SDA)	-1919	-312.1	78	OSC1	503.8	-312.1

**ML9479B**

Pad number	Pad name	X-coordinate (μm)	Y-coordinate (μm)	Pad number	Pad name	X-coordinate (μm)	Y-coordinate (μm)
79	OSC1	559.8	-312.1	124	BIAS	3251.4	-312.1
80	OSC1	615.8	-312.1	125	TEST2	3321.6	-312.1
81	OSC1	671.8	-312.1	126	TEST2	3377.6	-312.1
82	OSC1	727.8	-312.1	127	TEST2	3433.6	-312.1
83	OSC2	790.4	-312.1	128	TEST2	3489.6	-312.1
84	OSC2	846.4	-312.1	129	TEST1	3559.8	-312.1
85	OSC2	902.4	-312.1	130	TEST1	3615.8	-312.1
86	OSC2	958.4	-312.1	131	TEST1	3671.8	-312.1
87	OSC2	1014.4	-312.1	132	TEST1	3727.8	-312.1
88	OSCR	1090.4	-312.1	133	GNDO	3798	-312.1
89	OSCR	1146.4	-312.1	134	GNDO	3854	-312.1
90	OSCR	1202.4	-312.1	135	DUMMY	3924.2	-312.1
91	OSCR	1258.4	-312.1	136	DUMMY	3984.2	-312.1
92	OSCR	1314.4	-312.1	137	DUMMY	4044.2	-312.1
93	CKO	1389.8	-312.1	138	DUMMY	4104.2	-312.1
94	CKO	1445.8	-312.1	139	DUMMY	4164.2	-312.1
95	CKO	1501.8	-312.1	140	DUMMY	4224.2	-312.1
96	CKO	1557.8	-312.1	141	DUMMY	4308.9	-232.2
97	CKO	1613.8	-312.1	142	DUMMY	4308.9	-182.2
98	SYNCB	1694	-312.1	143	COM1	4308.9	-132.2
99	SYNCB	1750	-312.1	144	COM2	4308.9	-82.2
100	SYNCB	1806	-312.1	145	COM3	4308.9	-32.2
101	SYNCB	1862	-312.1	146	COM4	4308.9	17.8
102	SYNCB	1918	-312.1	147	DUMMY	4308.9	67.8
103	VDDO	2004.4	-312.1	148	DUMMY	4308.9	117.8
104	VDDO	2060.4	-312.1	149	DUMMY	4308.9	167.8
105	I2C	2130.6	-312.1	150	DUMMY	4308.9	217.8
106	I2C	2186.6	-312.1	151	DUMMY	4308.9	267.8
107	I2C	2242.6	-312.1	152	DUMMY	4225	308.9
108	I2C	2298.6	-312.1	153	DUMMY	4175	308.9
109	M/S	2368.8	-312.1	154	DUMMY	4125	308.9
110	M/S	2424.8	-312.1	155	SEG1	4075	308.9
111	M/S	2480.8	-312.1	156	SEG2	4025	308.9
112	M/S	2536.8	-312.1	157	SEG3	3975	308.9
113	POCEB	2607	-312.1	158	SEG4	3925	308.9
114	POCEB	2663	-312.1	159	SEG5	3875	308.9
115	POCEB	2719	-312.1	160	SEG6	3825	308.9
116	POCEB	2775	-312.1	161	SEG7	3775	308.9
117	OSCI/E	2845.2	-312.1	162	SEG8	3725	308.9
118	OSCI/E	2901.2	-312.1	163	SEG9	3675	308.9
119	OSCI/E	2957.2	-312.1	164	SEG10	3625	308.9
120	OSCI/E	3013.2	-312.1	165	SEG11	3575	308.9
121	BIAS	3083.4	-312.1	166	SEG12	3525	308.9
122	BIAS	3139.4	-312.1	167	SEG13	3475	308.9
123	BIAS	3195.4	-312.1	168	SEG14	3425	308.9

**ML9479B**

Pad number	Pad name	X-coordinate (μm)	Y-coordinate (μm)	Pad number	Pad name	X-coordinate (μm)	Y-coordinate (μm)
169	SEG15	3375	308.9	214	SEG60	1125	308.9
170	SEG16	3325	308.9	215	SEG61	1075	308.9
171	SEG17	3275	308.9	216	SEG62	1025	308.9
172	SEG18	3225	308.9	217	SEG63	975	308.9
173	SEG19	3175	308.9	218	SEG64	925	308.9
174	SEG20	3125	308.9	219	SEG65	875	308.9
175	SEG21	3075	308.9	220	SEG66	825	308.9
176	SEG22	3025	308.9	221	SEG67	775	308.9
177	SEG23	2975	308.9	222	SEG68	725	308.9
178	SEG24	2925	308.9	223	SEG69	675	308.9
179	SEG25	2875	308.9	224	SEG70	625	308.9
180	SEG26	2825	308.9	225	SEG71	575	308.9
181	SEG27	2775	308.9	226	SEG72	525	308.9
182	SEG28	2725	308.9	227	SEG73	475	308.9
183	SEG29	2675	308.9	228	SEG74	425	308.9
184	SEG30	2625	308.9	229	SEG75	375	308.9
185	SEG31	2575	308.9	230	SEG76	325	308.9
186	SEG32	2525	308.9	231	SEG77	275	308.9
187	SEG33	2475	308.9	232	SEG78	225	308.9
188	SEG34	2425	308.9	233	SEG79	175	308.9
189	SEG35	2375	308.9	234	SEG80	125	308.9
190	SEG36	2325	308.9	235	COM1	75	308.9
191	SEG37	2275	308.9	236	COM2	25	308.9
192	SEG38	2225	308.9	237	COM3	-25	308.9
193	SEG39	2175	308.9	238	COM4	-75	308.9
194	SEG40	2125	308.9	239	SEG81	-125	308.9
195	SEG41	2075	308.9	240	SEG82	-175	308.9
196	SEG42	2025	308.9	241	SEG83	-225	308.9
197	SEG43	1975	308.9	242	SEG84	-275	308.9
198	SEG44	1925	308.9	243	SEG85	-325	308.9
199	SEG45	1875	308.9	244	SEG86	-375	308.9
200	SEG46	1825	308.9	245	SEG87	-425	308.9
201	SEG47	1775	308.9	246	SEG88	-475	308.9
202	SEG48	1725	308.9	247	SEG89	-525	308.9
203	SEG49	1675	308.9	248	SEG90	-575	308.9
204	SEG50	1625	308.9	249	SEG91	-625	308.9
205	SEG51	1575	308.9	250	SEG92	-675	308.9
206	SEG52	1525	308.9	251	SEG93	-725	308.9
207	SEG53	1475	308.9	252	SEG94	-775	308.9
208	SEG54	1425	308.9	253	SEG95	-825	308.9
209	SEG55	1375	308.9	254	SEG96	-875	308.9
210	SEG56	1325	308.9	255	SEG97	-925	308.9
211	SEG57	1275	308.9	256	SEG98	-975	308.9
212	SEG58	1225	308.9	257	SEG99	-1025	308.9
213	SEG59	1175	308.9	258	SEG100	-1075	308.9
259	SEG101	-1125	308.9	304	SEG146	-3375	308.9
260	SEG102	-1175	308.9	305	SEG147	-3425	308.9
261	SEG103	-1225	308.9	306	SEG148	-3475	308.9
262	SEG104	-1275	308.9	307	SEG149	-3525	308.9

**ML9479B**

Pad number	Pad name	X-coordinate (μm)	Y-coordinate (μm)	Pad number	Pad name	X-coordinate (μm)	Y-coordinate (μm)
263	SEG105	-1325	308.9	308	SEG150	-3575	308.9
264	SEG106	-1375	308.9	309	SEG151	-3625	308.9
265	SEG107	-1425	308.9	310	SEG152	-3675	308.9
266	SEG108	-1475	308.9	311	SEG153	-3725	308.9
267	SEG109	-1525	308.9	312	SEG154	-3775	308.9
268	SEG110	-1575	308.9	313	SEG155	-3825	308.9
269	SEG111	-1625	308.9	314	SEG156	-3875	308.9
270	SEG112	-1675	308.9	315	SEG157	-3925	308.9
271	SEG113	-1725	308.9	316	SEG158	-3975	308.9
272	SEG114	-1775	308.9	317	SEG159	-4025	308.9
273	SEG115	-1825	308.9	318	SEG160	-4075	308.9
274	SEG116	-1875	308.9	319	DUMMY	-4125	308.9
275	SEG117	-1925	308.9	320	DUMMY	-4175	308.9
276	SEG118	-1975	308.9	321	DUMMY	-4225	308.9
277	SEG119	-2025	308.9	322	DUMMY	-4308.9	203.2
278	SEG120	-2075	308.9	323	DUMMY	-4308.9	153.2
279	SEG121	-2125	308.9	324	DUMMY	-4308.9	103.2
280	SEG122	-2175	308.9	325	DUMMY	-4308.9	53.2
281	SEG123	-2225	308.9	326	COM4	-4308.9	3.2
282	SEG124	-2275	308.9	327	COM3	-4308.9	-46.8
283	SEG125	-2325	308.9	328	COM2	-4308.9	-96.8
284	SEG126	-2375	308.9	329	COM1	-4308.9	-146.8
285	SEG127	-2425	308.9	330	DUMMY	-4308.9	-196.8
286	SEG128	-2475	308.9	331	DUMMY	-4308.9	-246.8
287	SEG129	-2525	308.9				
288	SEG130	-2575	308.9	A	A-MARK	4308.9	-312.1
289	SEG131	-2625	308.9	B	A-MARK	-4305.9	305.9
290	SEG132	-2675	308.9				
291	SEG133	-2725	308.9				
292	SEG134	-2775	308.9				
293	SEG135	-2825	308.9				
294	SEG136	-2875	308.9				
295	SEG137	-2925	308.9				
296	SEG138	-2975	308.9				
297	SEG139	-3025	308.9				
298	SEG140	-3075	308.9				
299	SEG141	-3125	308.9				
300	SEG142	-3175	308.9				
301	SEG143	-3225	308.9				
302	SEG144	-3275	308.9				
303	SEG145	-3325	308.9				

**REVISION HISTORY**

Document No.	Issue Date	Page		Description
		Previous Edition	New Edition	
FEDL9479B-01	June. 22,2010	–	–	Final edition 1 issued

**NOTICE**

1. The information contained herein can change without notice owing to product and/or technical improvements. Before using the product, please make sure that the information being referred to is up-to-date.
2. The outline of action and examples for application circuits described herein have been chosen as an explanation for the standard action and performance of the product. When planning to use the product, please ensure that the external conditions are reflected in the actual circuit, assembly, and program designs.
3. When designing your product, please use our product below the specified maximum ratings and within the specified operating ranges including, but not limited to, operating voltage, power dissipation, and operating temperature.
4. **OKI SEMICONDUCTOR assumes no responsibility or liability whatsoever for any failure or unusual or unexpected operation resulting from misuse, neglect, improper installation, repair, alteration or accident, improper handling, or unusual physical or electrical stress including, but not limited to, exposure to parameters beyond the specified maximum ratings or operation outside the specified operating range.**
5. Neither indemnity against nor license of a third party's industrial and intellectual property right, etc. is granted by us in connection with the use of the product and/or the information and drawings contained herein. No responsibility is assumed by us for any infringement of a third party's right which may result from the use thereof.
6. The products listed in this document are intended for use in general electronics equipment for commercial applications (e.g., office automation, communication equipment, measurement equipment, consumer electronics, etc.). These products are not, unless specifically authorized by OKI SEMICONDUCTOR, authorized for use in any system or application that requires special or enhanced quality and reliability characteristics nor in any system or application where the failure of such system or application may result in the loss or damage of property, or death or injury to humans. Such applications include, but are not limited to, traffic and automotive equipment, safety devices, aerospace equipment, nuclear power control, medical equipment, and life-support systems.
7. Certain products in this document may need government approval before they can be exported to particular countries. The purchaser assumes the responsibility of determining the legality of export of these products and will take appropriate and necessary steps at their own expense for these.
8. No part of the contents contained herein may be reprinted or reproduced without our prior permission.

Copyright 2010 OKI SEMICONDUCTOR CO., LTD.