



16Mb Synchronous DRAM

Features

- High Performance:

		-10 CL=3	-12 CL=3	Units
f_{CK}	Clock Frequency	100	83	MHz
t_{CK}	Clock Cycle	10	12	ns
t_{AC}	Clock Access Time	8	9	ns

- Single Pulsed \overline{RAS} Interface
- Fully Synchronous to Positive Clock Edge
- Dual Banks controlled by A11 (Bank Select)
- Programmable CAS Latency: 1,2,3
- Programmable Burst Length: 1,2,4,8,full-page
- Programmable Wrap Sequence: Sequential or Interleave

- Multiple Burst Read with Single Write Option
- Automatic and Controlled Precharge Command
- Data Mask for Read/Write control (x4,x8)
- Dual Data Mask for byte control (x16)
- Auto Refresh (CBR) and Self Refresh
- Suspend Mode and Power Down Mode
- 4096 refresh cycles/64ms
- Random Column Address every CLK (1-N Rule)
- Single 3.3V \pm 0.3V Power Supply
- LVTTTL compatible
- Package: 44 pin 400 mil TSOP-Type II (x4,x8)
50 pin 400 mil TSOP-Type II (x16)

Description

The IBM0316409C, IBM0316809C, and IBM0316169C are dual bank Synchronous DRAM's organized as 2Mbit x 4 I/O x 2 Bank, 1Mbit x 8 I/O x 2 Bank, and 512Kbit x 16 I/O x 2 Bank, respectively. These synchronous devices achieve high speed data transfer rates of up to 100MHz by employing a chip architecture that prefetches multiple bits and then synchronizes the output data to a system clock. The chip is fabricated with IBM's advanced 16Mbit single transistor CMOS DRAM process technology.

The device is designed to comply with all JEDEC standards set for synchronous DRAM products, both electrically and mechanically. All of the control, address and data input/output circuits are synchronized with the positive edge of an externally supplied clock.

\overline{RAS} , \overline{CAS} , \overline{WE} , and \overline{CS} are pulsed signals which are examined at the positive edge of each externally applied clock (CLK). Internal chip operating modes are defined by combinations of these signals and a command decoder initiates the necessary timings for each operation. A twelve bit address bus accepts address data in the conventional $\overline{RAS/CAS}$ multiplexing style. Eleven row

addresses (A0-A10) and a bank select address (A11) are strobed with \overline{RAS} . Ten column addresses (A0-A9) plus a bank select address (A11) are strobed with \overline{CAS} . Column address A9 is dropped on the x8 device and column addresses A8 and A9 are dropped on the x16 device.

Prior to any access operation, the \overline{CAS} latency, burst length, and burst sequence must be programmed into the device by address inputs A0-A9 during a mode register set cycle. In addition, it is possible to program a multiple burst sequence with single write cycle for write through cache operation.

Operating the two memory banks in an interleave fashion allows random access operation to occur at a higher rate than is possible with standard DRAMs. A sequential and gapless data rate of up to 100MHz is possible depending on burst length, \overline{CAS} latency, and speed grade of the device.

Auto Refresh (CBR) and Self Refresh operation are supported. These devices operate with a single 3.3V \pm 0.3V power supply and are available in 400mil TSOP Type II packages.

16Mb Synchronous DRAM

Pin Assignments (Top View)

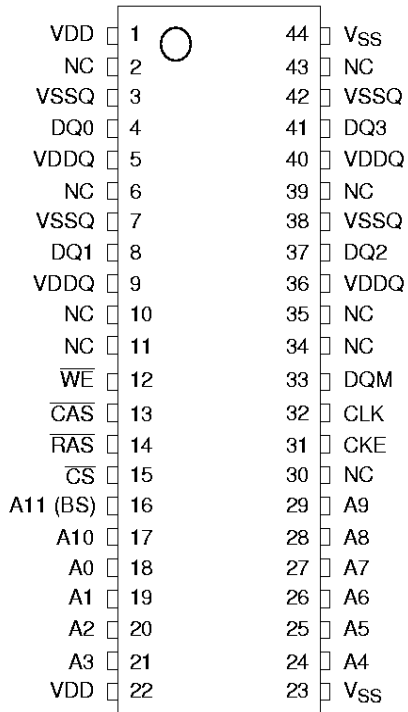

44-pin Plastic TSOP(II) 400 mil

2Mbit x 4 I/O x 2 Bank

IBM0316409CT3

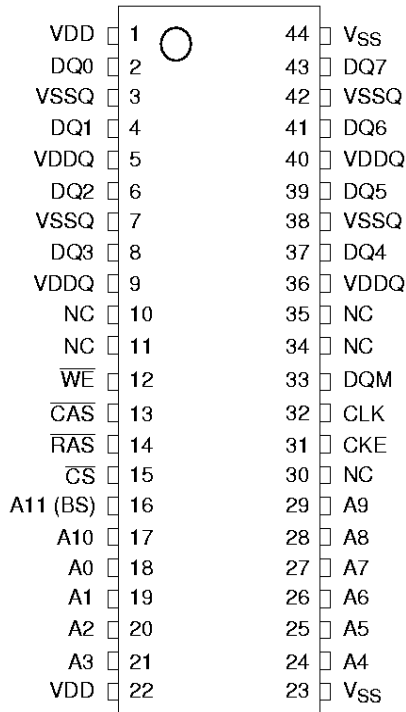

44-pin Plastic TSOP(II) 400 mil

1Mbit x 8 I/O x 2 Bank

IBM0316809CT3

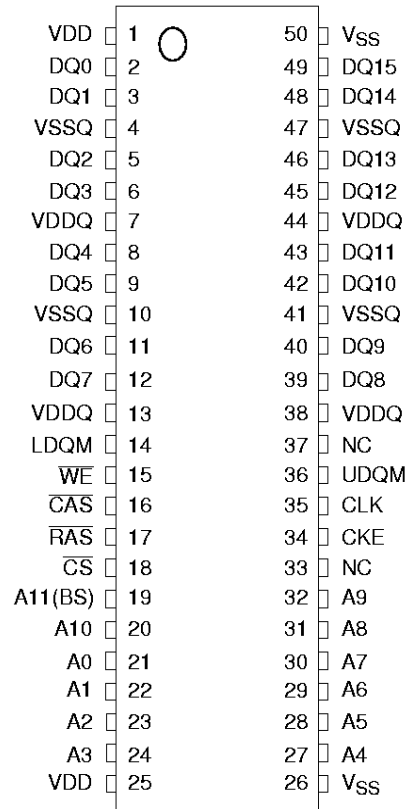

50-pin Plastic TSOP(II) 400 mil

512Kbit x 16 I/O x 2 Bank

IBM0316169CT3

Pin Description

CLK	Clock Input	DQ0-DQ15	Data Input/Output
CKE	Clock Enable	DQM, LDQM, UDQM	Data Mask
CS	Chip Select	VDD	Power (+3.3V)
RAS	Row Address Strobe	VSS	Ground
CAS	Column Address Strobe	VDDQ	Power for DQ's (+3.3V)
WE	Write Enable	VSSQ	Ground for DQ's
A11 (BS)	Bank Select	NC	No Connection
A0 - A10	Address Inputs	—	—



Input/Output Functional Description

Symbol	Type	Signal	Polarity	Function
CLK	Input	Pulse	Positive Edge	The system clock input. All of the SDRAM inputs are sampled on the rising edge of the clock.
CKE	Input	Level	Active High	Activates the CLK signal when high and deactivates the CLK signal when low. By deactivating the clock, CKE low initiates the Power Down mode, Suspend mode, or the Self Refresh mode.
\overline{CS}	Input	Pulse	Active Low	\overline{CS} enables the command decoder when low and disables the command decoder when high. When the command decoder is disabled, new commands are ignored but previous operations continue.
RAS, CAS WE	Input	Pulse	Active Low	When sampled at the positive rising edge of the clock, CAS, RAS, and WE define the operation to be executed by the SDRAM.
A11 (BS)	Input	Level	—	Selects which bank is to be active. A11 low selects bank A and A11 high selects bank B.
A0 - A10	Input	Level	—	During a Bank Activate command cycle, A0-A10 defines the row address (RA0-RA10) when sampled at the rising clock edge. During a Read or Write command cycle, A0-A9 defines the column address (CA0-CA9) when sampled at the rising clock edge. In addition to the column address, A10 is used to invoke autoprecharge operation at the end of the burst read or write cycle. If A10 is high, autoprecharge is selected and A11 defines the bank to be precharged (low=bank A, high=bank B). If A10 is low, autoprecharge is disabled. During a Precharge command cycle, A10 is used in conjunction with A11 to control which bank(s) to precharge. If A10 is high, both bank A and bank B will be precharged regardless of the state of A11. If A10 is low, then A11 is used to define which bank to precharge.
DQ0 - DQ15	Input Output	Level	—	Data Input/Output pins operate in the same manner as on conventional DRAMs.
DQM LDQM UDQM	Input	Pulse	Active Low	The Data Input/Output mask places the DQ buffers in a high impedance state when sampled high. In Read mode, DQM has a latency of two clock cycles and controls the output buffers like an output enable. In Write mode, DQM has a latency of zero and operates as a word mask by allowing input data to be written if it is low but blocks the write operation if DQM is high.
VDD, VSS	Supply	—	—	Power and ground for the input buffers and the core logic.
VDDQ VSSQ	Supply	—	—	Isolated power supply and ground for the output buffers to provide improved noise immunity.



Ordering Information

Part Number	CAS Latencies	Power Supply	Clock Cycle	Package	Org.
IBM0316409CT3-10	1,2,3	3.3V	10ns	400mil Type II TSOP-44	x4
IBM0316409CT3-12	1,2,3	3.3V	12ns	400mil Type II TSOP-44	x4
IBM0316809CT3-10	1,2,3	3.3V	10ns	400mil Type II TSOP-44	x8
IBM0316809CT3-12	1,2,3	3.3V	12ns	400mil Type II TSOP-44	x8
IBM0316169CT3-10	1,2,3	3.3V	10ns	400mil Type II TSOP-50	x16
IBM0316169CT3-12	1,2,3	3.3V	12ns	400mil Type II TSOP-50	x16



Block Diagram (2Mbit x 4 I/O x 2 Bank)

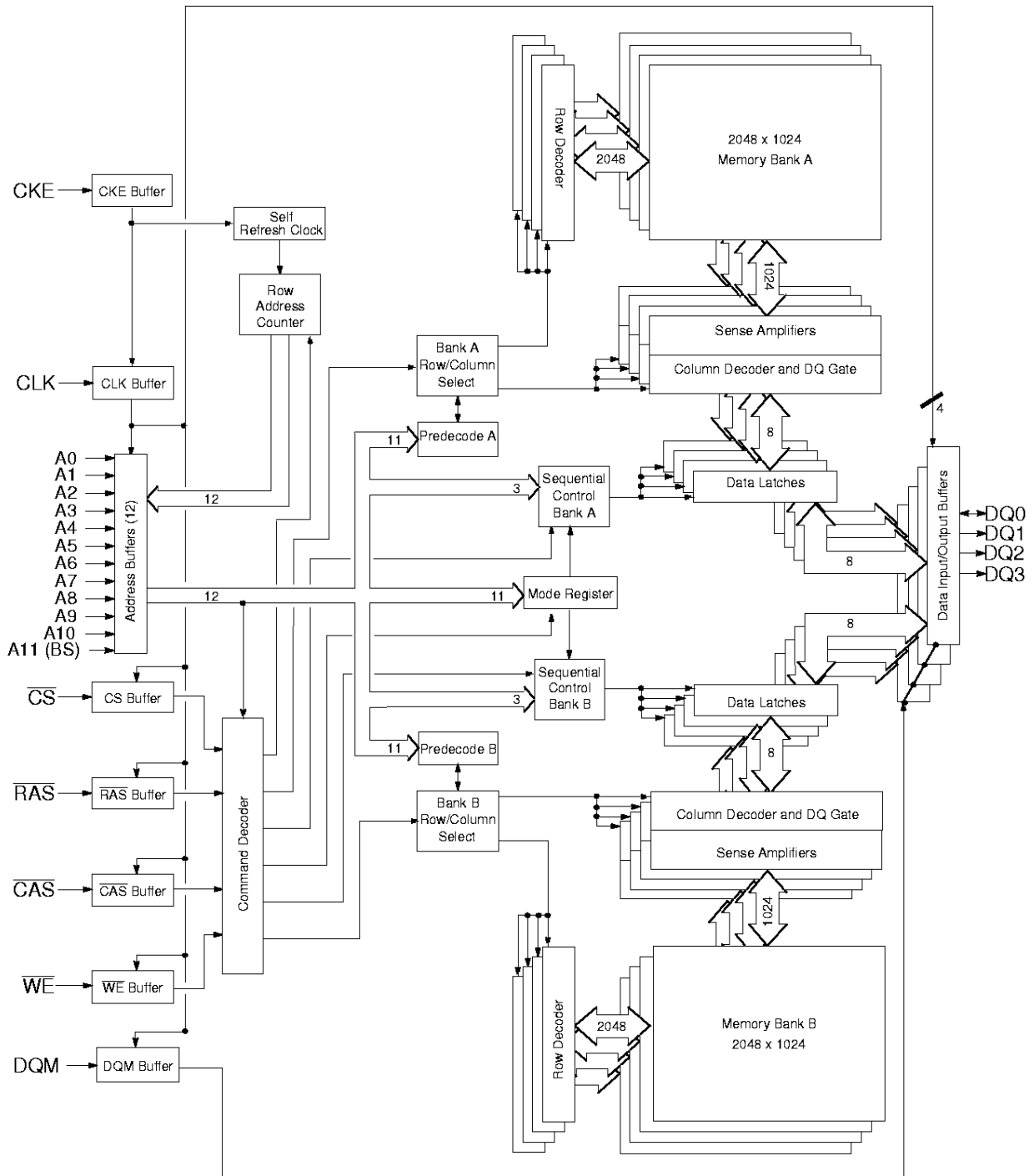



Block Diagram (1Mbit x 8 I/O x 2 Bank)

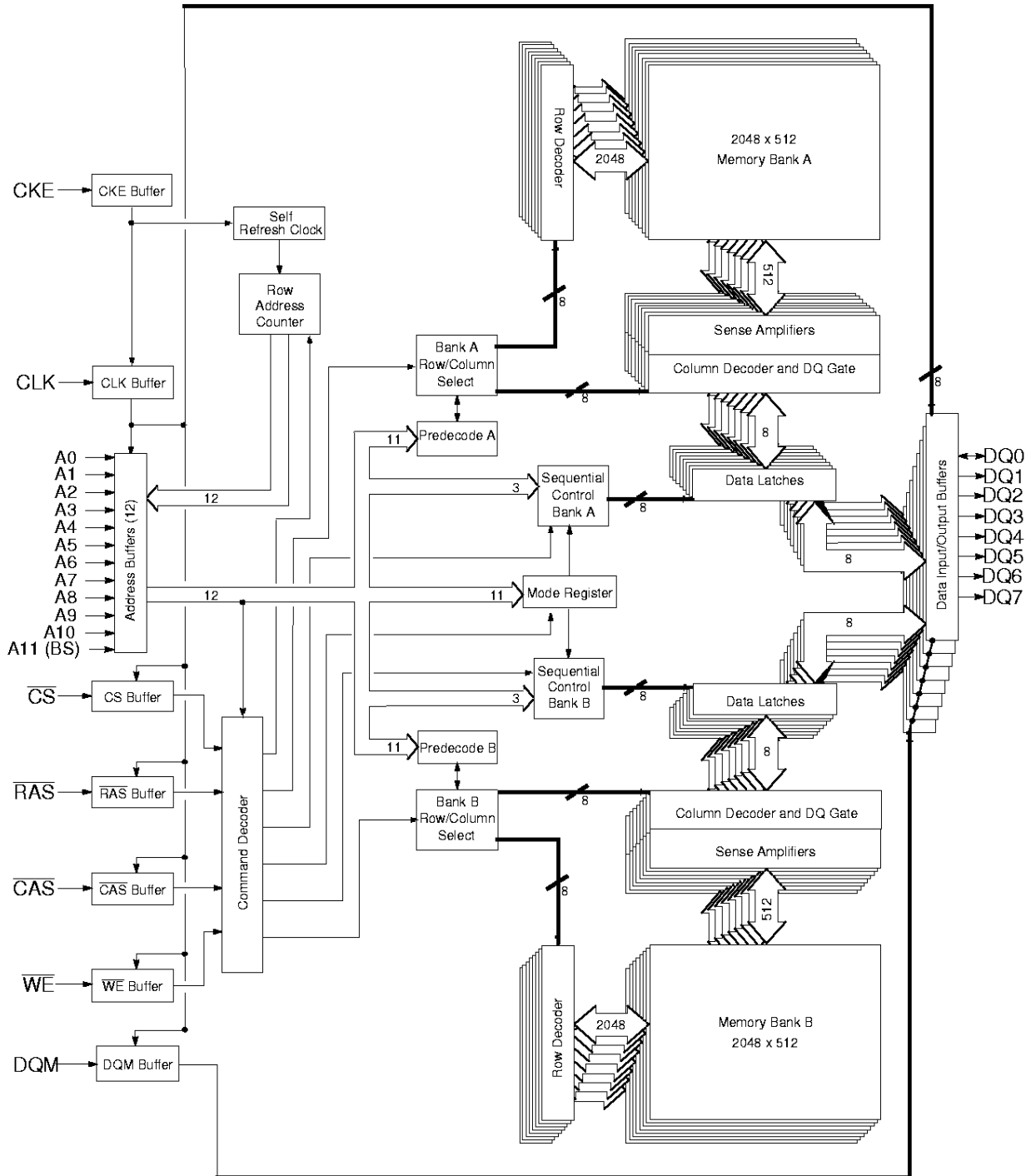

Block Diagram (512Kbit x 16 I/O x 2 Bank)

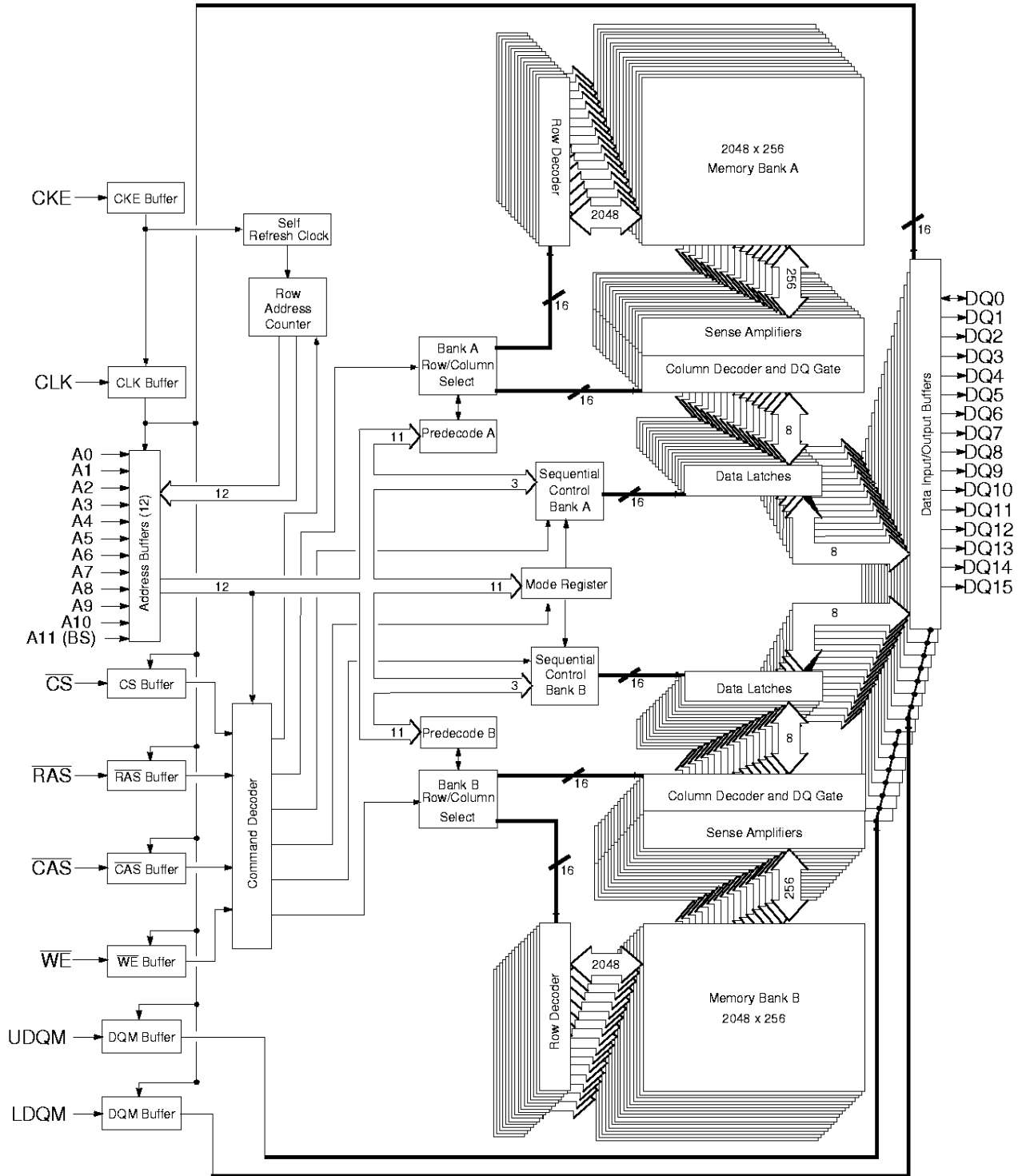

Power On and Initialization

The default power on state of the mode register is supplier specific and may be undefined. The following power on and initialization sequence guarantees the device is preconditioned to each users specific needs.

Like a conventional DRAM, the Synchronous DRAM must be powered up and initialized in a predefined manner. During power on, all VDD and VDDQ pins must be built up simultaneously to the specified voltage no later than any of the input signal voltages. The power on voltage must not exceed $VDD+0.3V$ on any of the input pins or VDD supplies. After power on, an initial pause of $100\mu s$ is required followed by a precharge of both banks using the precharge command. In an attempt to reduce the possibility of data contention on the DQ bus during power on, it is recommended that the DQM pin(s) be held high during the initial pause period. Once both banks have been precharged, a minimum of two Auto Refresh cycles (CBR) must occur before the Mode Register can be programmed. Failure to follow these steps may lead to unpredictable start-up modes.

Programming the Mode Register

For application flexibility, \overline{CAS} latency, burst length, burst sequence, and operation type are user defined variables and must be programmed into the SDRAM Mode Register with a single Mode Register Set Command. Any content of the Mode Register can be altered by re-executing the Mode Register Set Command. If the user chooses to modify only a subset of the Mode Register variables, all four variables must be redefined when the Mode Register Set Command is issued.

After initial power up, the Mode Register Set Command must be issued before read or write cycles may begin. Both banks must be in a precharged state and CKE must be high at least one cycle before the Mode Register Set Command can be issued. The Mode Register Set Command is activated by the low signals of \overline{RAS} , \overline{CAS} , \overline{CS} and \overline{WE} at the positive edge of the clock. The address input data during this cycle defines the parameters to be set as shown in the Mode Register Operation table. A new command may be issued on the second clock following the mode register set command.

\overline{CAS} Latency

The \overline{CAS} latency is a parameter that is used to define the delay from when a Read Command is registered on a rising clock edge to when the data from that Read Command becomes available at the outputs. The \overline{CAS} latency is expressed in terms of clock cycles and can have a value of 1, 2, or 3 cycles. The value of the \overline{CAS} latency is determined by the speed grade of the device and the clock frequency that is used in the application. A table showing the relationship between the \overline{CAS} latency, speed grade, and clock frequency appears in the Electrical Characteristics section of this document. Once the appropriate \overline{CAS} latency has been selected it must be programmed into the mode register after power up, for an explanation of this procedure see Programming the Mode Register in the previous section.

Mode Register Operation (Address Input For Mode Set)

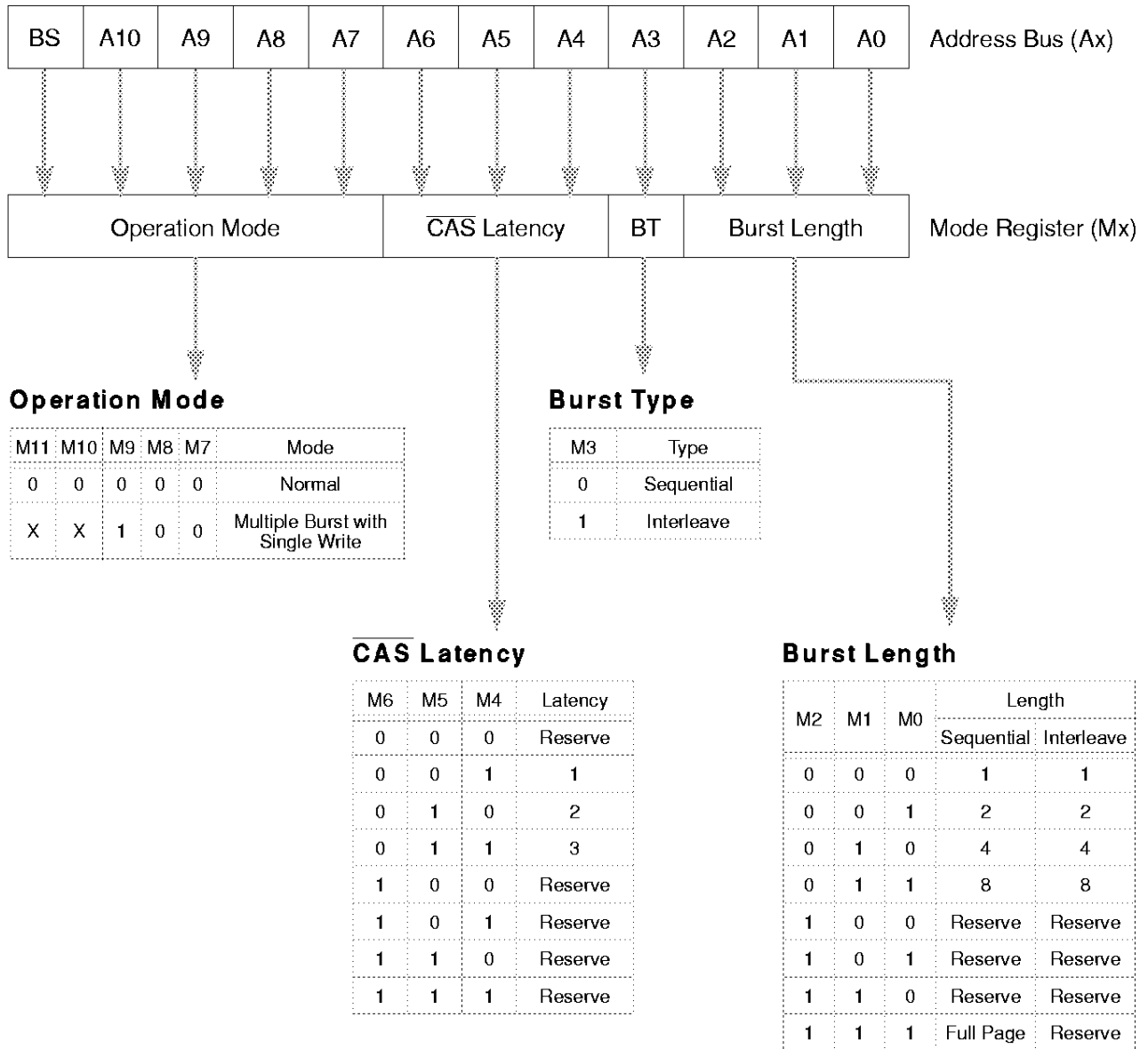



16Mb Synchronous DRAM

Burst Mode Operation

Burst mode operation is used to provide a constant flow of data to memory locations (write cycle), or from memory locations (read cycle). There are three parameters that define how the burst mode will operate. These parameters include burst sequence, burst length, and operation mode. The burst sequence and burst length are programmable, and are determined by address bits A0 - A3 during the Mode Register Set command. Operation mode is also programmable and is set by address bits A7 - A10 and BS.

The burst type is used to define the order in which the burst data will be delivered or stored to the SDRAM. Two types of burst sequences are supported, sequential and interleaved. See Table.

The burst length controls the number of bits that will be output after a Read Command, or the number of bits to be input after a Write Command. The burst length can be programmed to have values of 1, 2, 4, 8 or full page (actual page length is dependent on organization: x4, x8, or x16). Full page burst operation is only possible using the sequential burst type.

Burst operation mode can be normal operation or multiple burst with single write operation. Normal operation implies that the device will perform burst operations on both read and write cycles until the desired burst length is satisfied. Multiple burst with single write operation was added to support Write Through Cache operation. Here, the programmed burst length only applies to read cycles. All write cycles are single write operations when this mode is selected.

Burst Length and Sequence

Burst Length	Starting Address (A2 A1 A0)	Sequential Addressing (decimal)	Interleave Addressing (decimal)
2	x x 0	0, 1	0, 1
	x x 1	1, 0	1, 0
4	x 0 0	0, 1, 2, 3	0, 1, 2, 3
	x 0 1	1, 2, 3, 0	1, 0, 3, 2
	x 1 0	2, 3, 0, 1	2, 3, 0, 1
	x 1 1	3, 0, 1, 2	3, 2, 1, 0
8	0 0 0	0, 1, 2, 3, 4, 5, 6, 7	0, 1, 2, 3, 4, 5, 6, 7
	0 0 1	1, 2, 3, 4, 5, 6, 7, 0	1, 0, 3, 2, 5, 4, 7, 6
	0 1 0	2, 3, 4, 5, 6, 7, 0, 1	2, 3, 0, 1, 6, 7, 4, 5
	0 1 1	3, 4, 5, 6, 7, 0, 1, 2	3, 2, 1, 0, 7, 6, 5, 4
	1 0 0	4, 5, 6, 7, 0, 1, 2, 3	4, 5, 6, 7, 0, 1, 2, 3
	1 0 1	5, 6, 7, 0, 1, 2, 3, 4	5, 4, 7, 6, 1, 0, 3, 2
	1 1 0	6, 7, 0, 1, 2, 3, 4, 5	6, 7, 4, 5, 2, 3, 0, 1
	1 1 1	7, 0, 1, 2, 3, 4, 5, 6	7, 6, 5, 4, 3, 2, 1, 0
Full Page (Note)	n n n	Cn, Cn+1, Cn+2,	Not Supported

Note: Page length is a function of I/O organization and column addressing.

X4 organization (CA0-CA9); Page Length = 1024 bits

X8 organization (CA0-CA8); Page Length = 512 bits

X16 organization (CA0-CA7); Page Length = 256 bits

Bank Activate Command

In relation to the operation of a fast page mode DRAM, the Bank Activate command corresponds to a falling $\overline{\text{RAS}}$ signal. The Bank Activate command is issued by holding $\overline{\text{CAS}}$ and $\overline{\text{WE}}$ high with $\overline{\text{CS}}$ and $\overline{\text{RAS}}$ low at the rising edge of the clock. The bank select address, A_{11} (sometimes referred to as BS), is used to select the desired bank. If BS is low then bank A is activated, if BS is high then bank B is activated. The row address $\text{A}_0 - \text{A}_{10}$ is used to determine which row to activate in the selected bank.

The Bank Activate command must be applied before any Read or Write operation can be executed. The delay from when the Bank Activate command is applied to when the first read or write operation can begin must meet or exceed the $\overline{\text{RAS}}$ to $\overline{\text{CAS}}$ delay time (t_{RCD}). Once a bank has been activated it must be pre-charged before another Bank Activate command can be applied to the same bank. The minimum time interval between successive Bank Activate commands to the same bank is determined by the $\overline{\text{RAS}}$ cycle time of the device (t_{RC}). The minimum time interval between interleaved Bank Activate commands (Bank A to Bank B and vice versa) is the Bank to Bank delay time (t_{RRD}).

Bank Activate Command Cycle ($\overline{\text{CAS}}$ latency = 3)

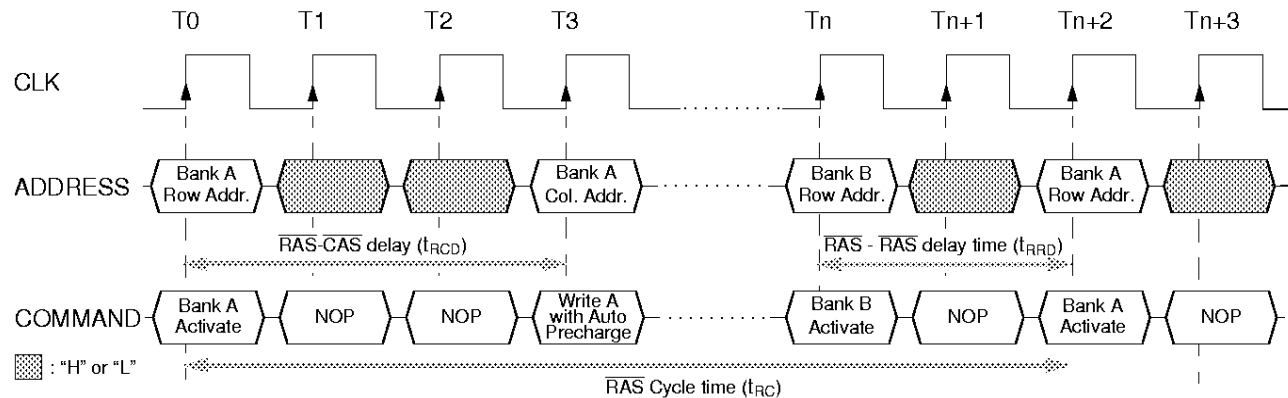

Read and Write Access Modes

After a bank has been activated, a read or write cycle can be executed. This is accomplished by setting $\overline{\text{RAS}}$ high and $\overline{\text{CAS}}$ low at the clock's rising edge after the necessary $\overline{\text{RAS}}$ to $\overline{\text{CAS}}$ delay (t_{RCD}). $\overline{\text{WE}}$ must also be defined at this time to determine whether the access cycle is a read operation ($\overline{\text{WE}}$ high), or a write operation ($\overline{\text{WE}}$ low).

The SDRAM provides a wide variety of fast access modes. A single Read or Write Command will initiate a serial read or write operation on successive clock cycles at data rates of up to 100MHz. The number of serial data bits for each access is equal to the burst length, which is programmed into the Mode Register. Although the burst length is user programmable, the boundary of the burst cycle is restricted to specific segments of the page length.

For example, the 2Mbit x 4 I/O x 2 Bank device has a page length of 1024 bits (defined by $\text{CA}_0 - \text{CA}_9$). If a burst length of 4 is programmed into the Mode Register, then 256 boundary segments (4-bits each) are addressable. The first access will begin at the column address supplied to the device during the READ or Write Command ($\text{CA}_0 - \text{CA}_9$). However, the second access is not necessarily the next higher order column address. The second access is a function of the starting address, the burst sequence, and burst boundary. Restated, the burst sequence is contained to four bits associated with one of the 256 possible boundary segments. The actual boundary segment (1 of 256) is determined by the eight higher order column addresses ($\text{CA}_2 - \text{CA}_9$). The first access within this boundary segment is determined by the two low order column addresses ($\text{CA}_0 - \text{CA}_1$) and the following three accesses are determined by the burst sequence.

16Mb Synchronous DRAM

The above discussion does not apply when full page burst is programmed into the Mode Register. Full page burst length works only with the sequential burst sequence and has no address boundaries. The SDRAM device will continue bursting data even after the entire page burst length has been satisfied. The burst sequence will start at the column address defined during the read or write cycle and will increment sequentially until the highest order column address has been reached. At this point, the burst counter will reset to address 0 and continue to perform burst read or burst write operations sequentially until either a Burst Stop Command is issued, a Precharge Command is issued to the bursting bank, or until a new Read or Write Command is issued which will interrupt the existing burst and begin a new burst at the new starting column address.

Similar to Page Mode of conventional DRAM's, a read or write cycle can not begin until the sense amplifiers latch the selected row address information. The refresh period (t_{REF}) is what limits the number of random column accesses to an activated bank. A new burst access can be done even before the previous burst ends. The ability to interrupt a burst operation at every clock cycle is supported, this is referred to as the 1-N rule. When the previous burst is interrupted by another Read or Write Command, the remaining addresses are overridden by the new address once the CAS Latency has been satisfied.

Precharging an active bank after each read or write operation is not necessary providing the same row is to be accessed again. To perform a read or write cycle to a different row within an activated bank, the bank must be precharged and a new Bank Activate command must be issued. When both Bank A and Bank B are activated, interleaved (ping pong) bank Read or Write operations are possible. By using the programmed burst length and alternating the access and precharge operations between the two banks, fast and seamless data access operation among many different pages can be realized. When the two banks are activated, column to column interleave operation can be done between two different pages. Finally, Read or Write Commands can be issued to the same bank or between active banks on every clock cycle.

Burst Read Command

The Burst Read command is initiated by having \overline{CS} and \overline{CAS} low while holding \overline{RAS} and \overline{WE} high at the rising edge of the clock. The address inputs determine the starting column address for the burst, the Mode Register sets type of burst (sequential or interleave) and the burst length (1, 2, 4, 8, full page). The delay from the start of the command to when the data from the first cell appears on the outputs is equal to the value of the CAS latency that is set in the Mode Register.

Burst Read Operation (Burst Length = 4, CAS latency = 1, 2, 3)

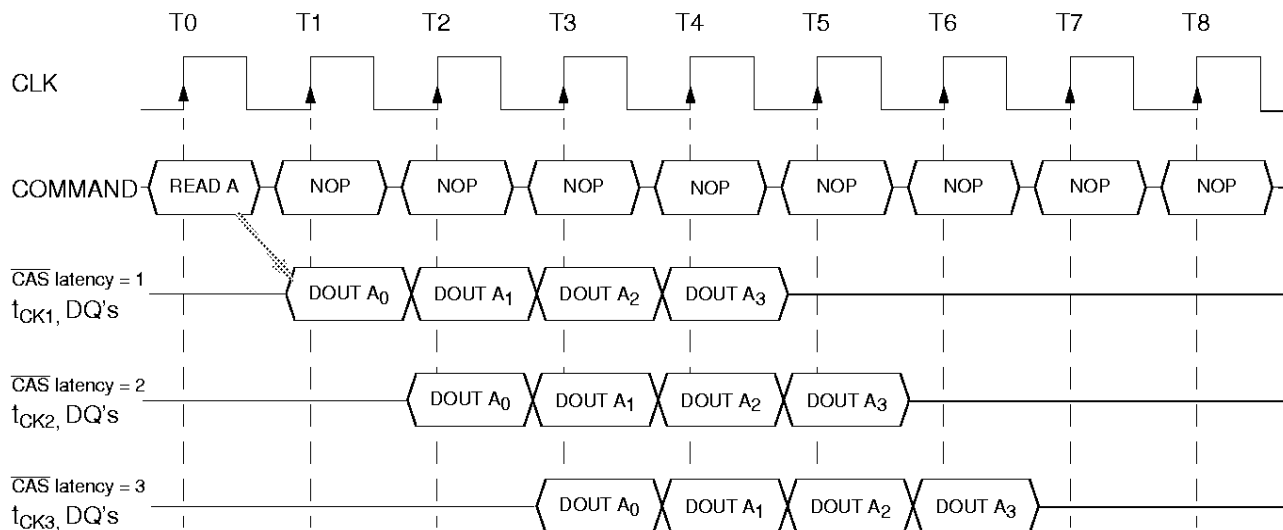

Read Interrupted by a Read

A Burst Read may be interrupted before completion of the burst by another Read Command, with the only restriction being that the interval that separates the commands must be at least one clock cycle. When the previous burst is interrupted, the remaining addresses are overridden by the new address with the full burst length. The data from the first Read Command continues to appear on the outputs until the $\overline{\text{CAS}}$ latency from the interrupting Read Command is satisfied, at this point the data from the interrupting Read Command appears.

(Burst Length = 4, $\overline{\text{CAS}}$ latency = 1, 2, 3)

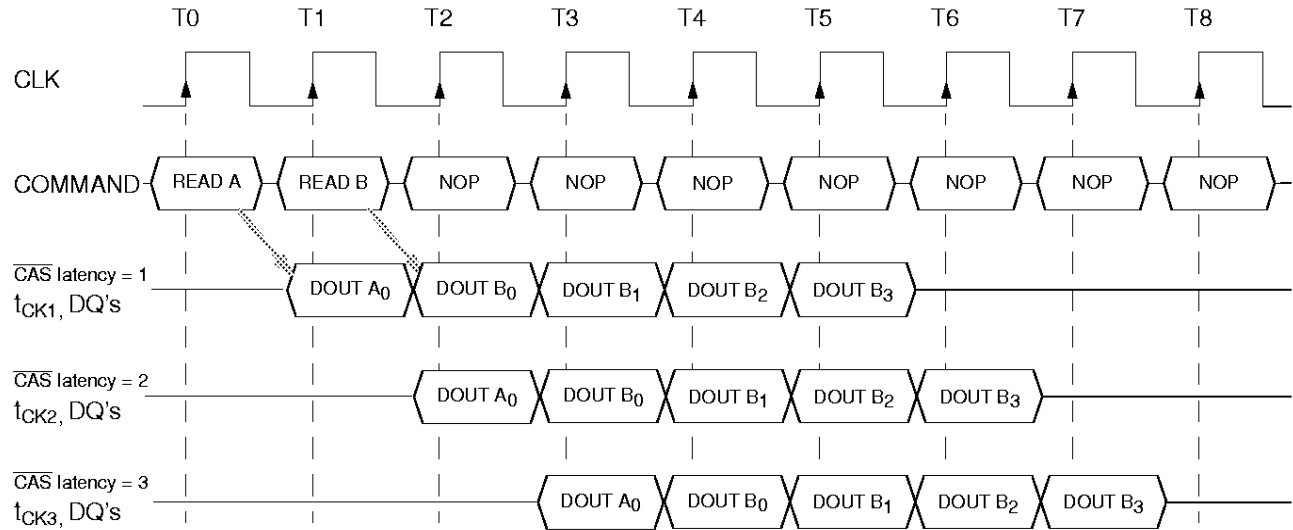

Read Interrupted by a Write

Dependent upon $\overline{\text{CAS}}$ Latency and burst length, there exist two methods in which a burst read operation can be interrupted by a Write Command and one situation in which a burst read operation can not be interrupted by a Write Command. To interrupt a burst read with a Write Command, DQM must be used to avoid data contention on the I/O bus by placing the DQ's (output drivers) in a high impedance state at least one clock cycle before the Write Command is initiated. To insure the DQ's are tri-stated one cycle before the write operation begins, DQM must be activated at least 3 clock cycles before the Write Command and be deactivated in the same clock cycle as the Write Command.



Method 1: $\overline{\text{CAS}}$ latency = 1 or 2, Burst Length = Any

When the $\overline{\text{CAS}}$ latency is 1 or 2, the minimum interval between the Read and Write commands is one clock cycle.

Minimum Read to Write Interval: Burst Length = 4, $\overline{\text{CAS}}$ latency = 1, 2

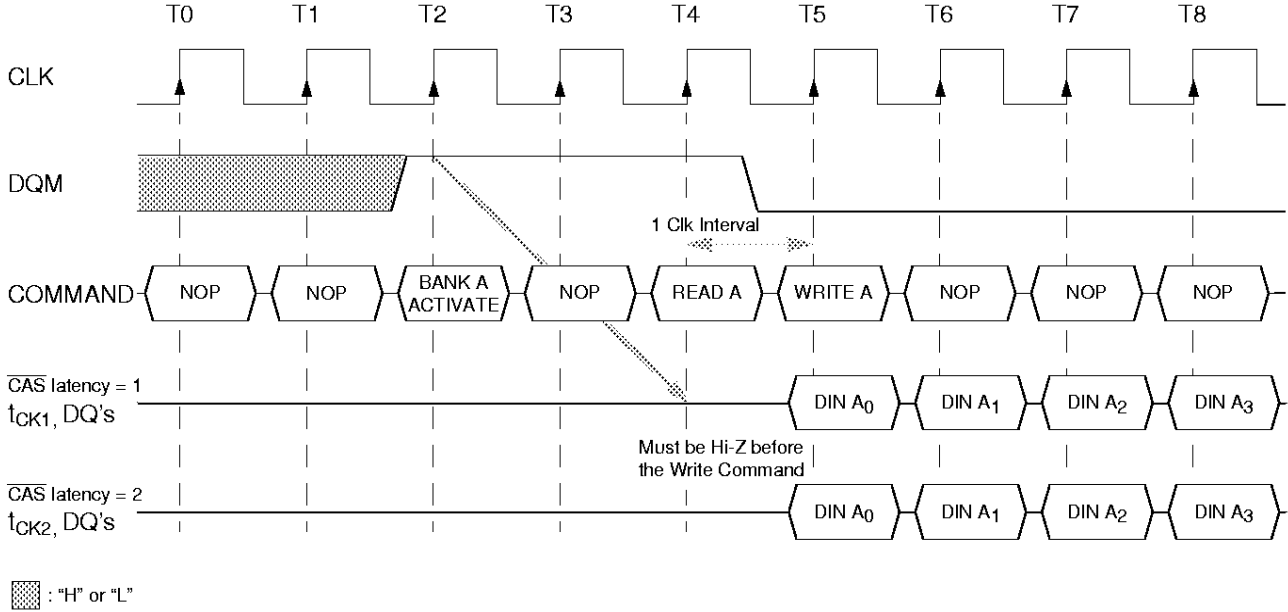

Non-minimum Read to Write Interval: Burst Length = 4, $\overline{\text{CAS}}$ latency = 1, 2

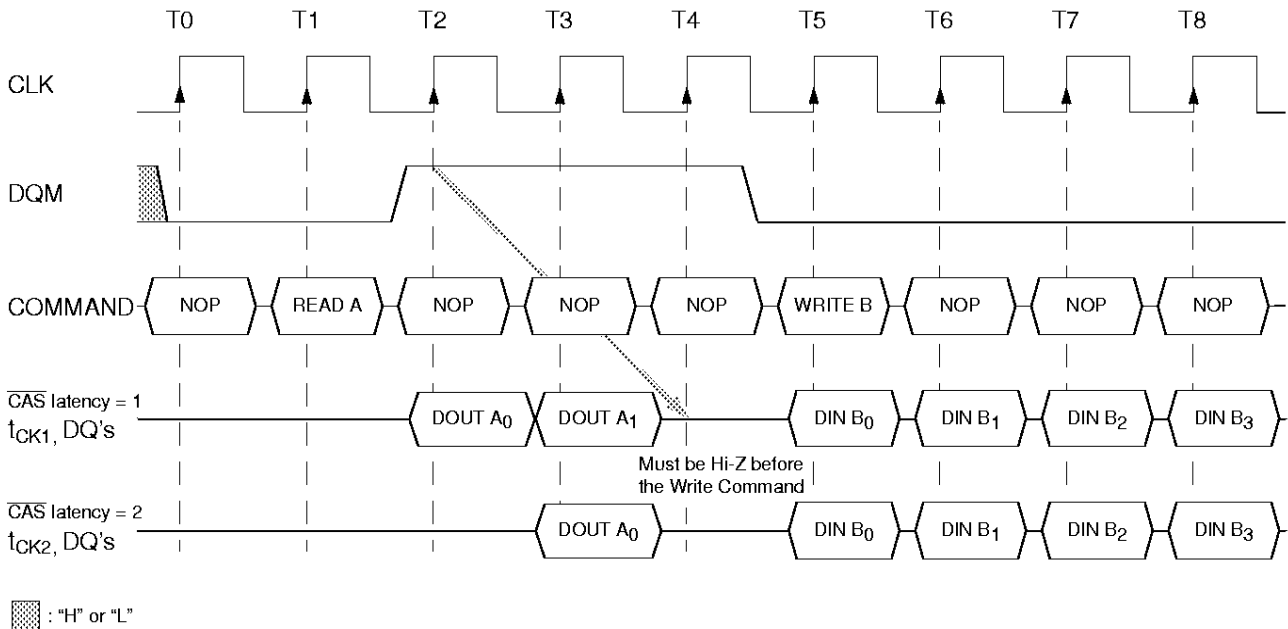

Method 2: CAS latency = 3, Burst Length = 1, 2, 4, or 8

If the CAS latency is 3 and the burst length is not full page, then a Burst Read operation can be interrupted by a Write command provided that the Write command occurs after a minimum interval of [burst length + 1] cycles.

Read to Write Interval: Burst Length = 4, CAS latency = 3

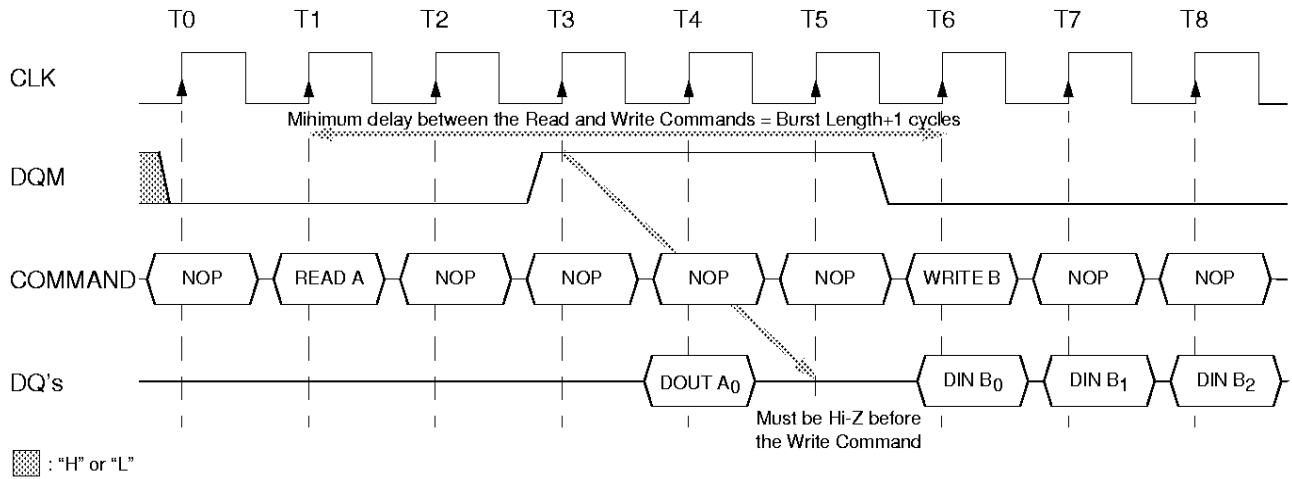

If the CAS latency is 3 and the burst length is full page, then a Burst Read operation can never be interrupted by a Write command. In this situation, the Burst Read operation must be interrupted by a Burst Stop Command before a Write operation can be issued to the open bank.

Burst Write Command

The Burst Write command is initiated by having \overline{CS} , \overline{CAS} and \overline{WE} low while holding \overline{RAS} high at the rising edge of the clock. The address inputs determine the starting column address. There is no \overline{CAS} latency required for burst write cycles. Data for the first burst write cycle must be applied on the DQ pins on the same clock cycle that the Write Command is issued. The remaining data inputs must be supplied on each subsequent rising clock edge until the burst length is completed. When the burst has finished, any additional data supplied to the DQ pins will be ignored.

Burst Write Operation (Burst Length = 4, \overline{CAS} latency = 1, 2, or 3)

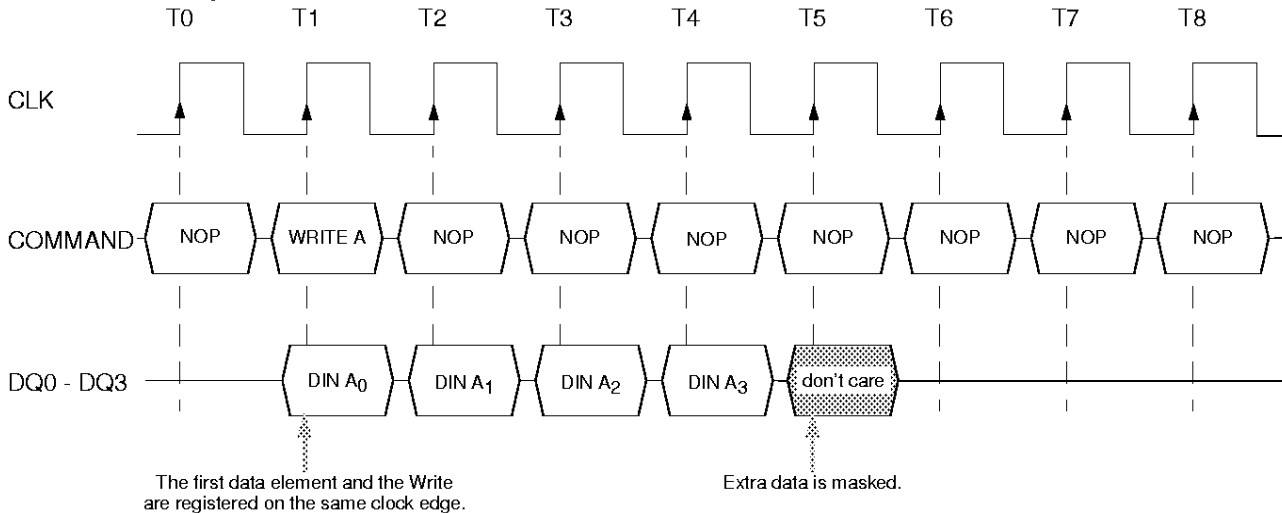

Write Interrupted by a Write

A burst write may be interrupted before completion of the burst by another Write Command. When the previous burst is interrupted, the remaining addresses are overridden by the new address and data will be written into the device until the programmed burst length is satisfied.

(Burst Length = 4, \overline{CAS} latency = 1, 2, or 3)

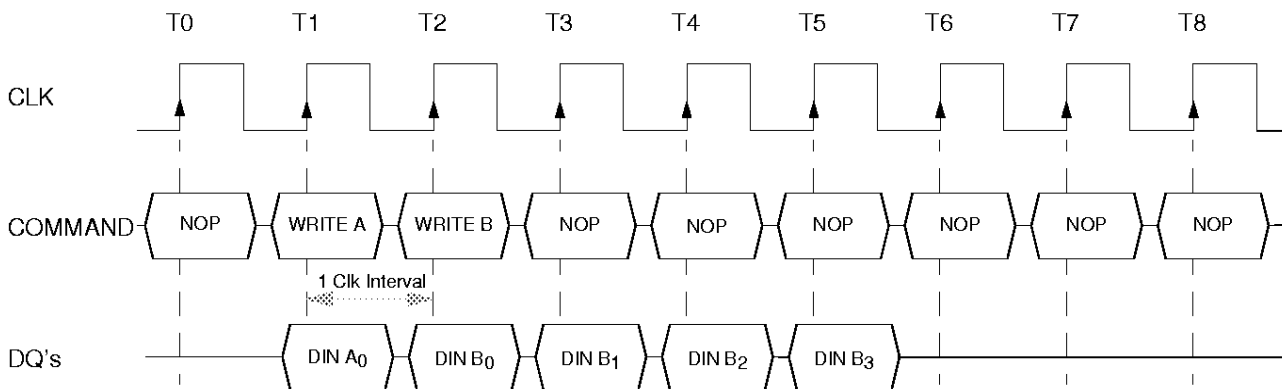

Write Interrupted by a Read

A Read Command will interrupt a burst write operation on the same clock cycle that the Read Command is registered. The DQ's must be in the high impedance state at least one cycle before the interrupting read data appears on the outputs to avoid data contention. When the Read Command is registered, any residual data from the burst write cycle will be ignored. Data that is presented on the DQ pins before the Read Command is initiated will actually be written to the memory.

(Burst Length = 4, CAS latency = 1, 2, 3)

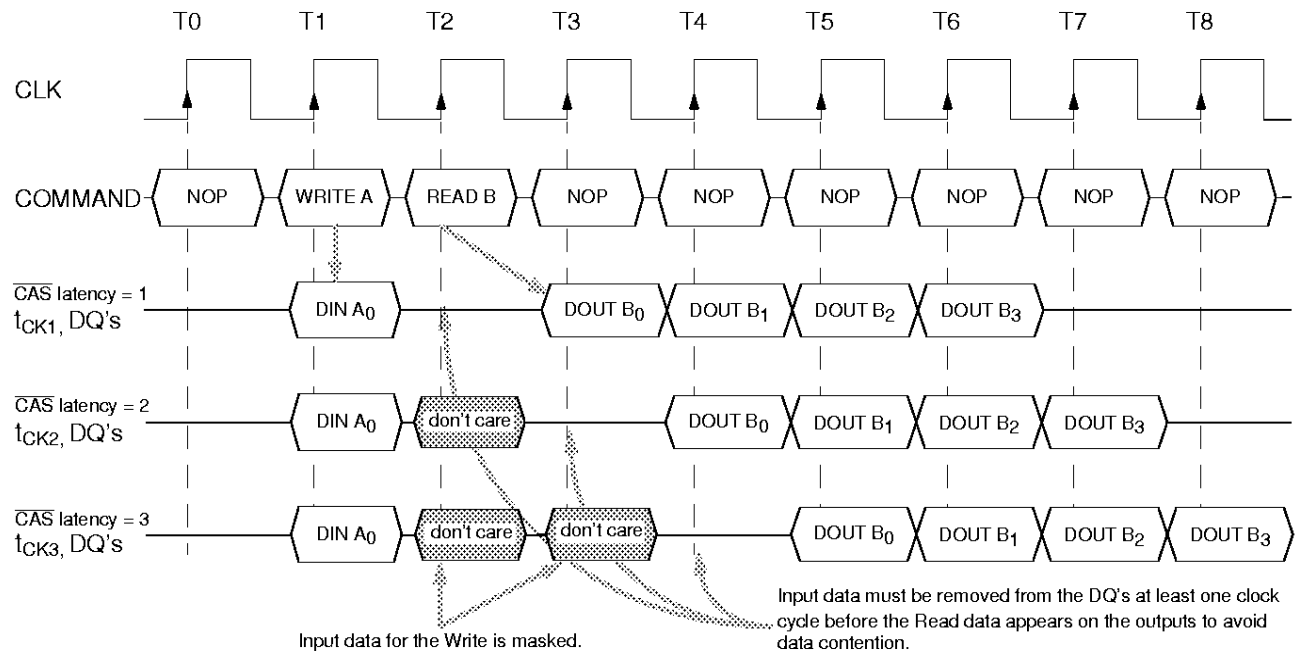

16Mb Synchronous DRAM

Burst Stop Command

Once a burst read or write operation has been initiated, there exist several methods in which to terminate the burst operation prematurely. These methods include using another Read or Write Command to interrupt an existing burst operation, use a Precharge Command to interrupt a burst cycle and close the active bank, or using the Burst Stop Command to terminate the existing burst operation but leave the bank open for future Read or Write Commands to the same page of the active bank. When interrupting a burst with another Read or Write Command care must be taken to avoid DQ contention. The Burst Stop Command, however, has the fewest restrictions making it the easiest method to use when terminating a burst operation before it has been completed. The Burst Stop Command is defined by having \overline{RAS} and \overline{CAS} high with \overline{CS} and \overline{WE} low at the rising edge of the clock.

When using the Burst Stop Command during a burst read cycle, the data DQ's go to a high impedance state after a delay which is equal to the CAS Latency set in the Mode Register.

Termination of a Burst Read Operation (Burst Length > 4, \overline{CAS} latency = 1, 2, 3)

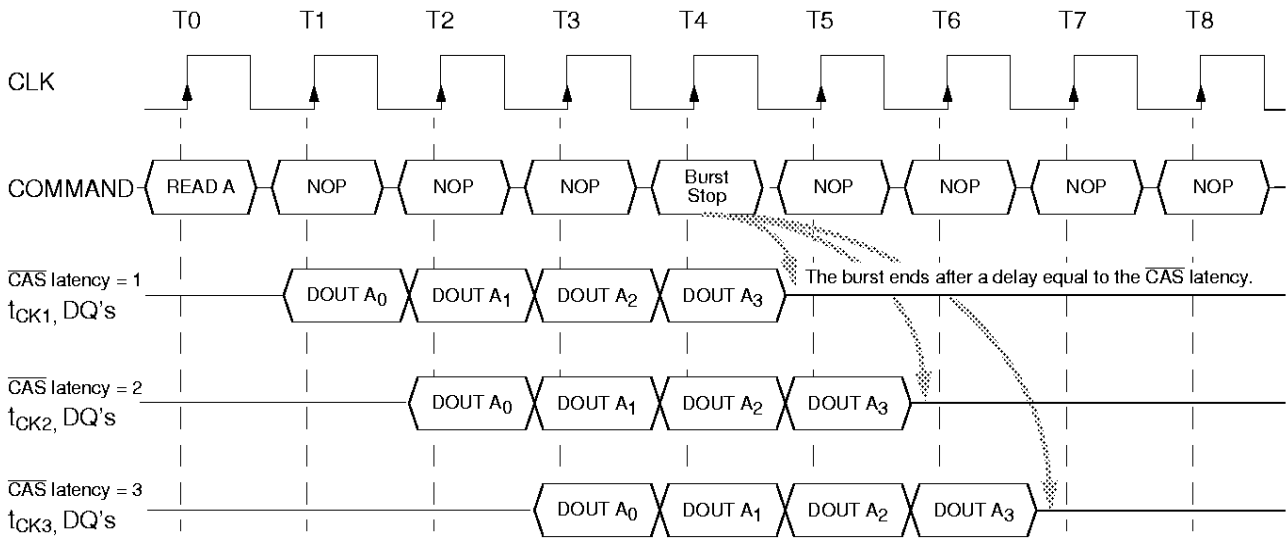

If a Burst Stop Command is issued during a burst write operation, then any residual data from the burst write cycle will be ignored. Data that is presented on the DQ pins before the Burst Stop Command is registered will be written to the memory.

Termination of a Burst Write Operation (Burst Length = X, \overline{CAS} latency = 1,2,3)

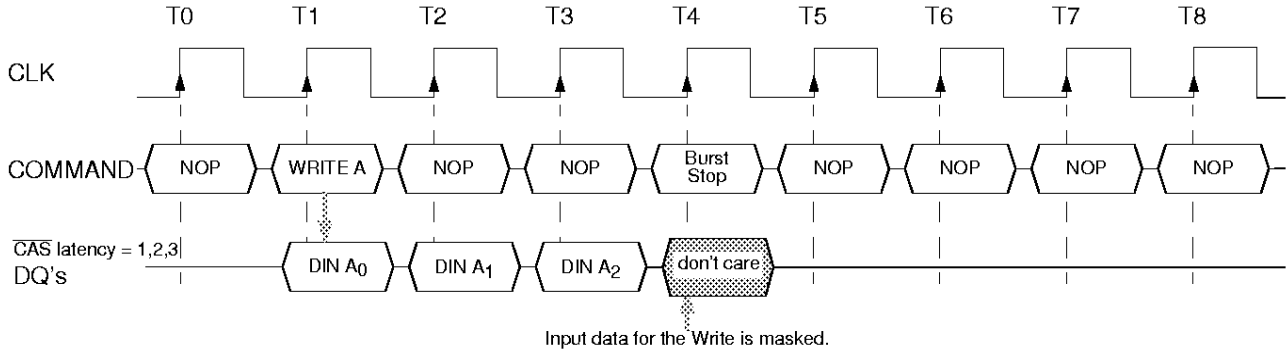

Auto-Precharge Operation

Before a new row in an active bank can be opened, the active bank must be precharged using either the Precharge Command or the auto-precharge function. When a Read or a Write Command is given to the SDRAM, the CAS timing accepts one extra address, column address A10, to allow the active bank to automatically begin precharge at the earliest possible moment during the burst read or write cycle. If A10 is low when the READ or WRITE Command is issued, then normal Read or Write burst operation is executed and the bank remains active at the completion of the burst sequence. If A10 is high when the Read or Write Command is issued, then the auto-precharge function is engaged. During autoprecharge, a Read Command will execute as normal with the exception that the active bank will begin to precharge before all burst read cycles have been completed. This feature allows the precharge operation to be partially or completely hidden during the burst read cycles (dependent upon burst length) thus improving system performance for random data access. Auto-precharge can also be implemented during Write commands although precharge can not begin any sooner than is possible by issuing the Precharge Command directly to the device.

A Read or Write Command without auto-precharge can be terminated in the midst of a burst operation. However, a Read or Write Command with auto-precharge can not be interrupted before the entire burst operation is completed. Therefore use of a Read, Write, Precharge, or Burst Stop Command is prohibited during a read or write cycle with auto-precharge.

If A10 is high when a Read Command is issued, the Read with Auto-Precharge function is initiated. The SDRAM automatically enters the precharge operation one clock after the Read Command is registered for CAS latencies of 1 and 2, and two clocks after the Read Command is registered for CAS latency of 3. Once the precharge operation has started the bank cannot be reactivated until the Precharge time (t_{RP}) has been satisfied. It should be noted that the device will not respond to the Auto-Precharge command if the device is programmed for full page burst read or write cycles, or full page burst read cycles with single write operation.

Burst Read with Autoprecharge (Burst Length = 4, CAS latency = 1, 2, 3)

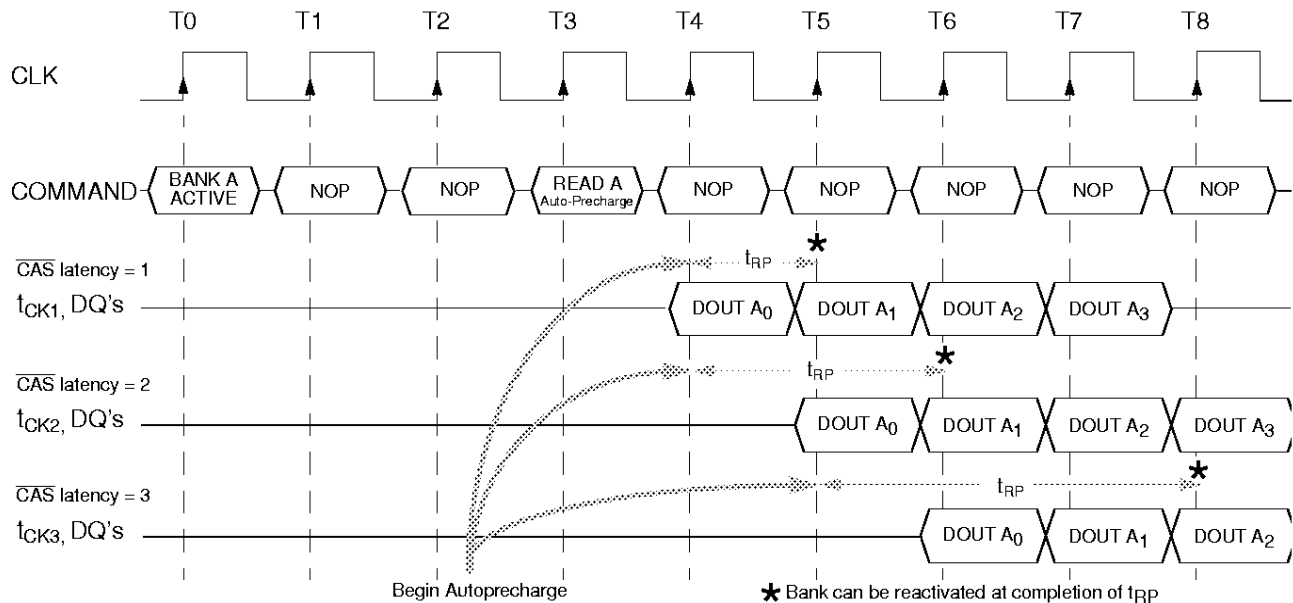

If A10 is high when a Write Command is issued, the Write with Auto-Precharge function is initiated. The SDRAM automatically enters the precharge operation one clock delay from the last burst write cycle for CASL = 1,2 or two clocks for CASL=3. This delay is referred to as t_{DPL} . The bank undergoing auto-precharge can not be reactivated until t_{DPL} and t_{RP} are satisfied. This is referred to as t_{DAL} , Data-in to Active delay ($t_{DAL} = t_{DPL} + t_{RP}$).



Burst Write with Auto-Precharge (Burst Length = 2, $\overline{\text{CAS}}$ latency = 1, 2, 3)

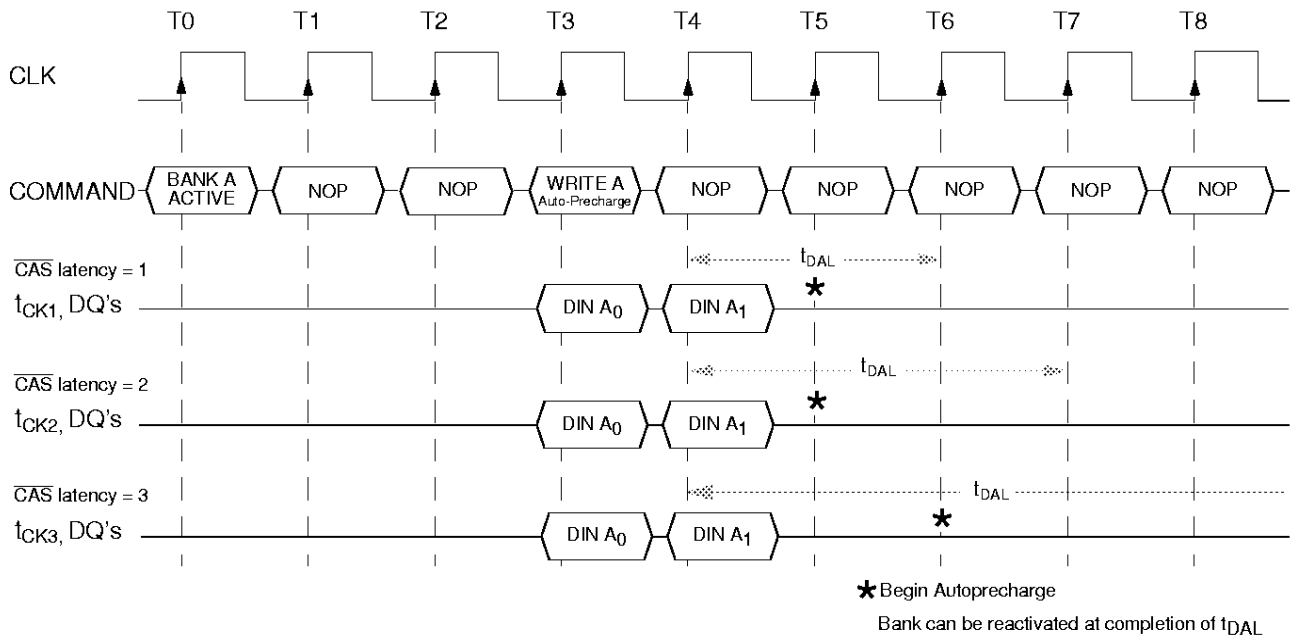

Precharge Command

The Precharge Command is used to precharge or close a bank that has been activated. The Precharge Command is triggered when $\overline{\text{CS}}$, $\overline{\text{RAS}}$ and $\overline{\text{WE}}$ are low and $\overline{\text{CAS}}$ is high at the rising edge of the clock. The Precharge Command can be used to precharge each bank separately or both banks simultaneously. Two address bits A10 and A11 (BS) are used to define which bank(s) is to be precharged when the command is issued.

Bank Selection for Precharge by Address Bits

A10	BS(A11)	Precharged Bank(s)
LOW	LOW	Bank A only
LOW	HIGH	Bank B only
HIGH	DON'T CARE	Both Banks A and B

For read cycles when $\overline{\text{CAS}}$ latency = 1, the Precharge Command may be applied coincident with the last clock of the burst read cycle. For Read cycles when $\overline{\text{CAS}}$ latency = 2 or 3, the Precharge Command may be applied coincident with the second to last clock of the burst read cycle.

For write cycles, however, a delay must be satisfied from the start of the last burst write cycle until the Precharge Command can be issued. This delay is known as t_{DPL} , Data-in to Precharge delay.

After the Precharge Command is issued, the precharged bank must be reactivated before a new read or write access can be executed. The delay between the Precharge Command and the Activate Command must be greater than or equal to the Precharge time (t_{RP}).



Burst Read followed by the Precharge Command (Burst Length = 4, $\overline{\text{CAS}}$ latency = 2)

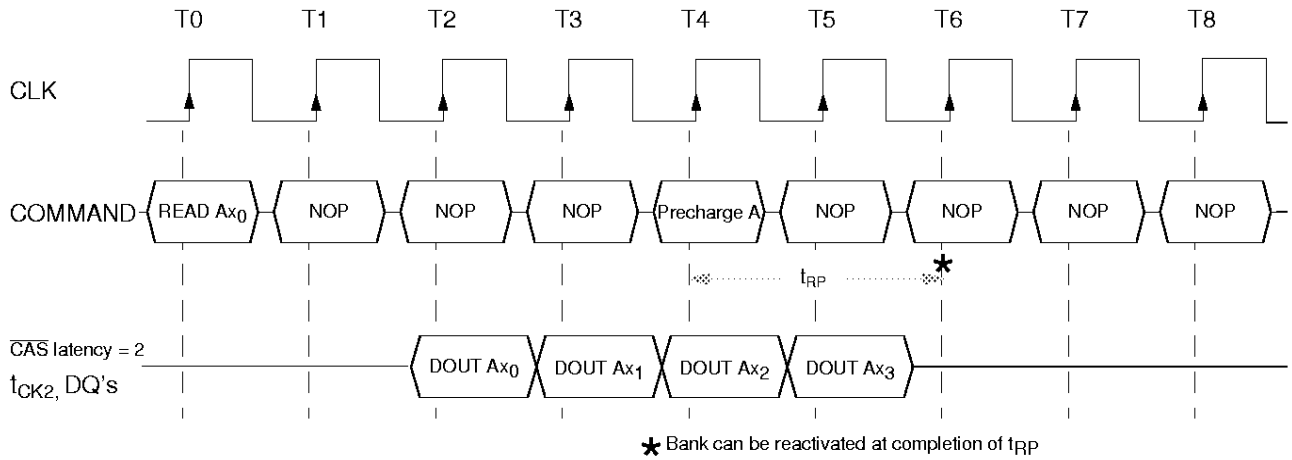

Burst Write followed by the Precharge Command (Burst Length = 2, $\overline{\text{CAS}}$ latency = 2)

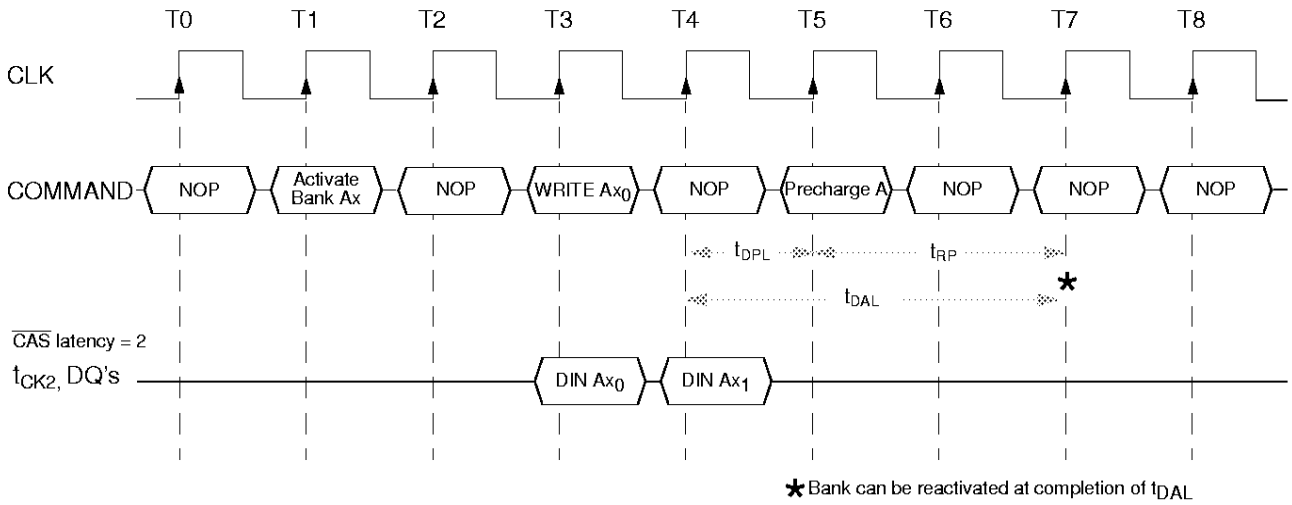

Precharge Termination

The Precharge Command may be used to terminate either a burst read or burst write operation. When the Precharge command is issued, the burst operation is terminated and bank precharge begins.

For burst read operations, valid data will continue to appear on the data bus as a function of $\overline{\text{CAS}}$ Latency. In addition, invalid data may also appear on the data bus for one or two subsequent clock cycles again as a function of $\overline{\text{CAS}}$ Latency. It is recommended that the DQM input(s) be asserted to mask this invalid data. (See "Burst Read Interrupted by Precharge" timing diagrams below.)

Burst Read Interrupted by Precharge (Burst Length = 8, $\overline{\text{CAS}}$ latency = 1)

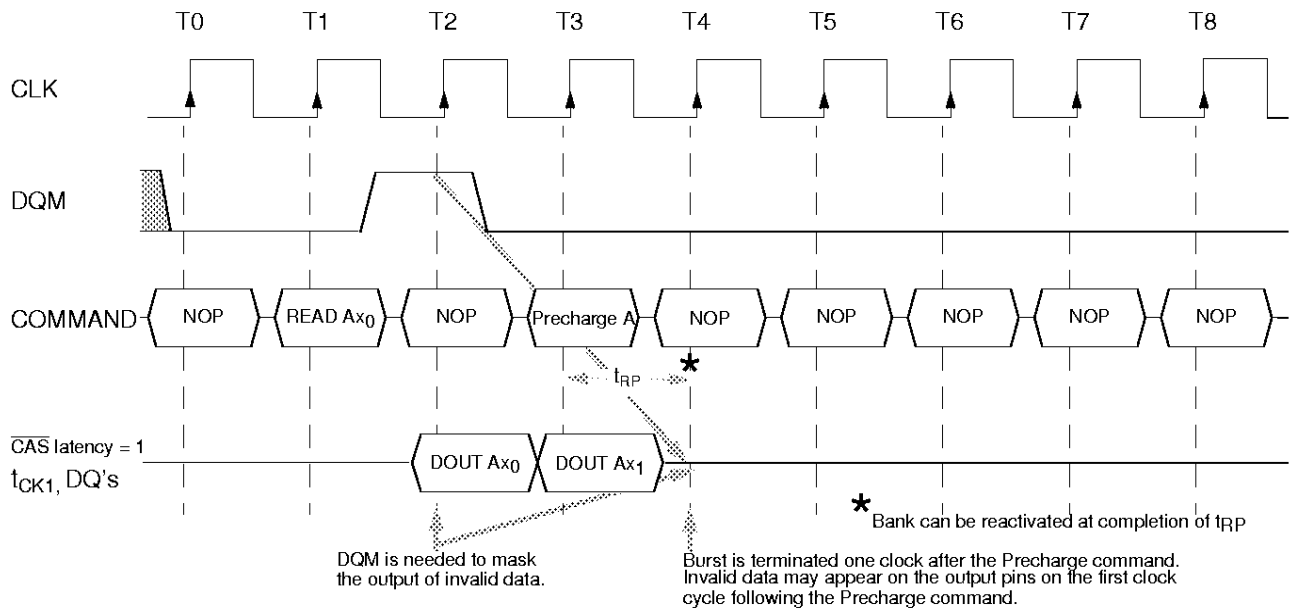

Burst Read Interrupted by Precharge (Burst Length = 8, $\overline{\text{CAS}}$ latency = 2)

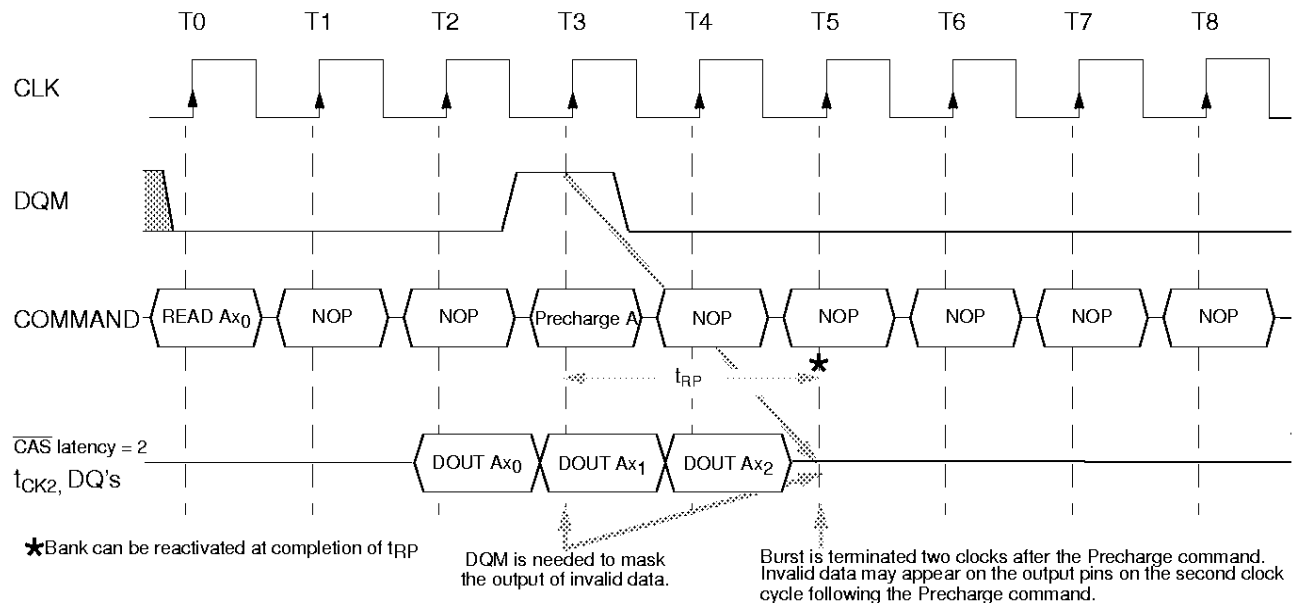

Burst Read Interrupted by Precharge (Burst Length = 8, CAS latency = 3)

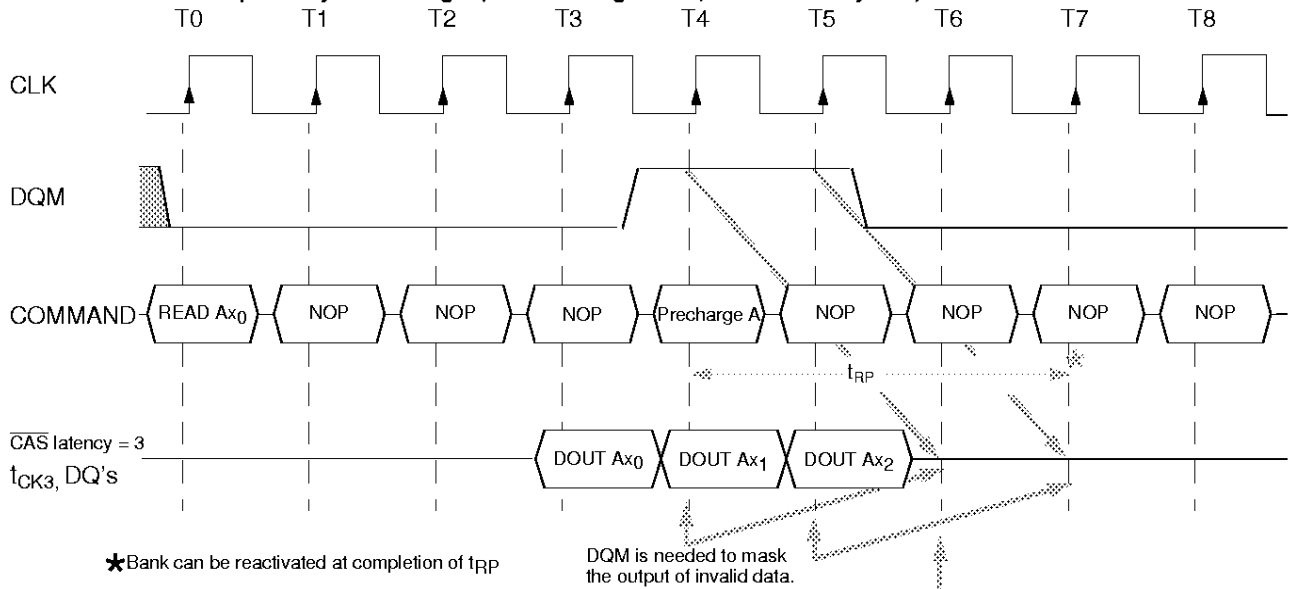

Burst is terminated two clocks after the Precharge command. Invalid data may appear on the output pins on the second and third clock cycles following the Precharge command.

Burst write operations will be terminated by the Precharge command. However, write data written to the device during the Precharge command or prior to the Precharge command may be stored incorrectly and is a function of $\overline{\text{CAS}}$ latency.

When $\overline{\text{CAS}}$ latency is set to equal 1 or 2, the last write data that will be properly stored in the device is that write data that is presented to the device on the clock cycle prior to the Precharge command. The write data presented during the Precharge command may be stored incorrectly. To prevent from writing invalid data to the device, DQM must be asserted high during the same clock cycle as the Precharge command to mask the invalid write data.

Precharge Termination of a Burst Write (Burst Length = 8, CAS Latency = 1)

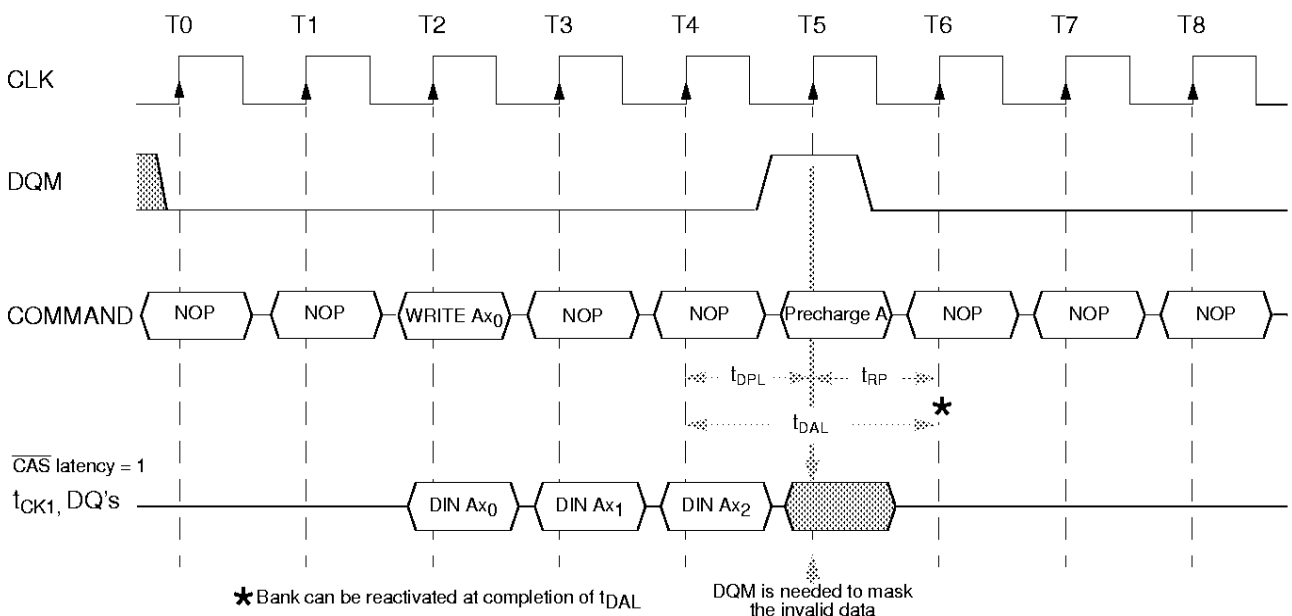

16Mb Synchronous DRAM

Precharge Termination of a Burst Write (Burst Length = 8, CAS Latency = 2)

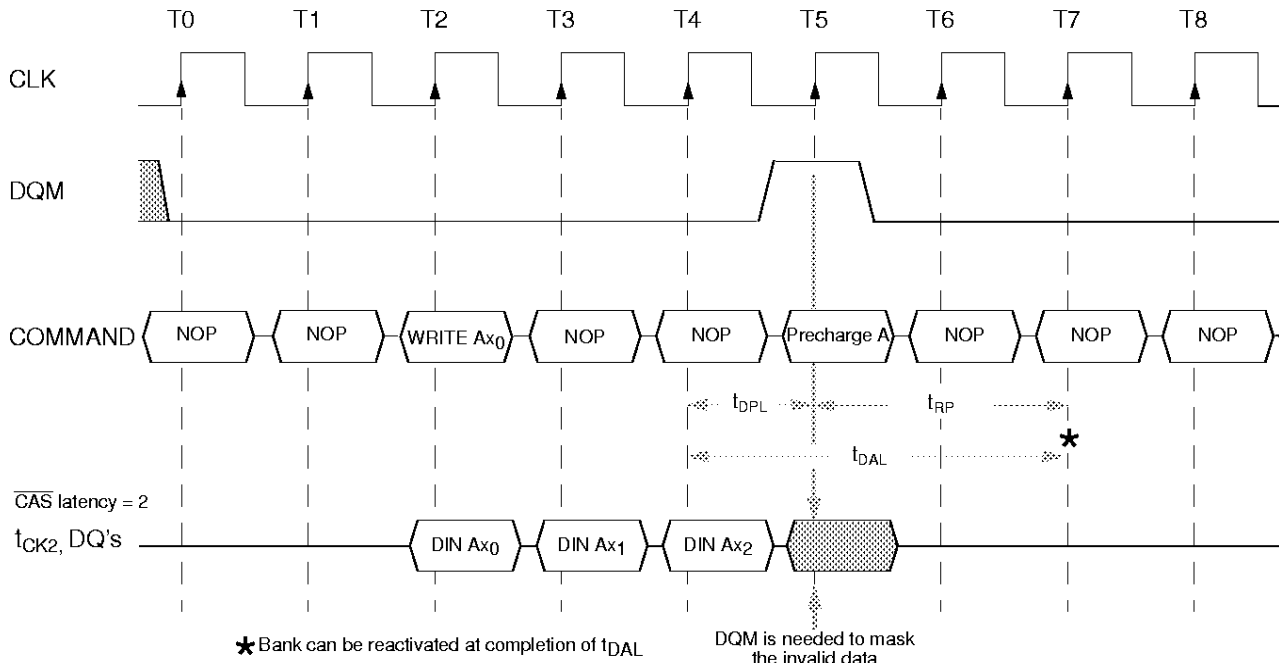

When $\overline{\text{CAS}}$ latency is set to equal 3, the last write data that will be properly stored in the device is that write data that is presented to the device two clocks prior to the Precharge command. The write data presented during the Precharge command and the clock cycle prior to the Precharge command may be stored incorrectly. To prevent from writing invalid data to the device, DQM must be asserted high one clock cycle prior to the Precharge command and on the same clock cycle as the Precharge command to mask the invalid write data.

Precharge Termination of a Burst Write (Burst Length = 8, CAS Latency = 3)

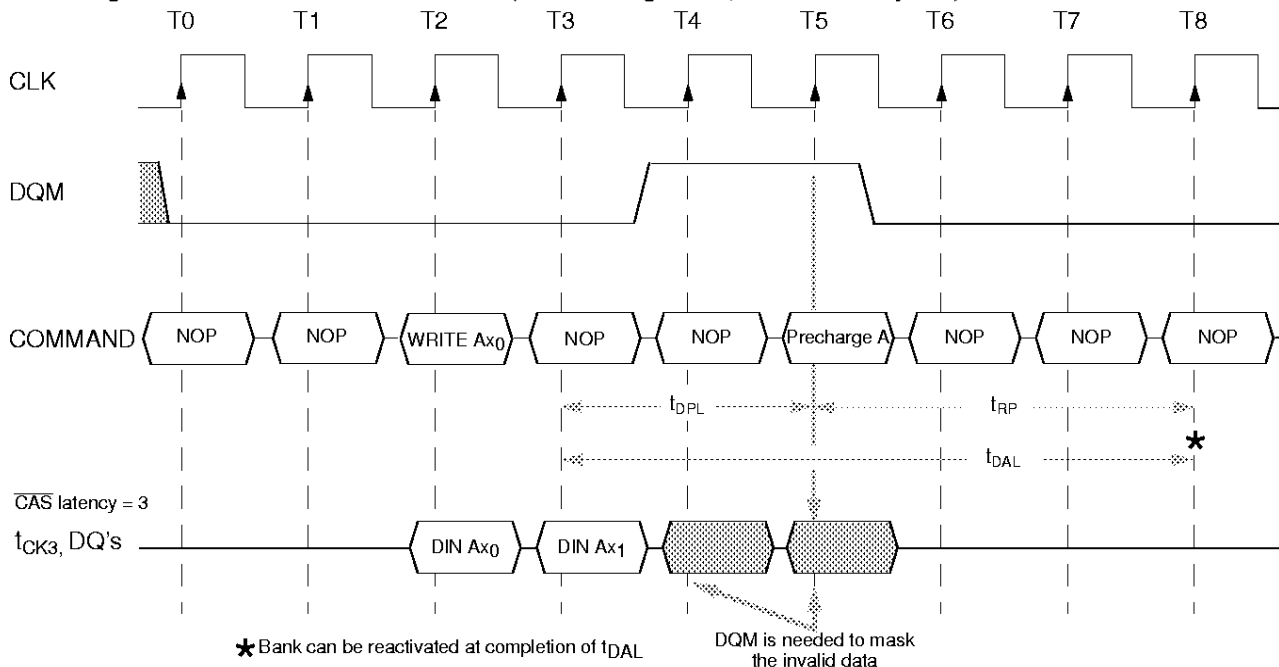

Automatic Refresh Command ($\overline{\text{CAS}}$ Before $\overline{\text{RAS}}$ Refresh)

When $\overline{\text{CS}}$, $\overline{\text{RAS}}$ and $\overline{\text{CAS}}$ are held low with CKE and $\overline{\text{WE}}$ high at the rising edge of the clock, the chip enters the Automatic Refresh mode (CBR). Both banks of the SDRAM must be precharged and idle for a minimum of the Precharge time (t_{RP}) before the Auto Refresh Command (CBR) can be applied. An address counter, internal to the device, decrements the word and bank address during the refresh cycle. No control of the external address pins is required once this cycle has started.

When the refresh cycle has completed, both banks of the SDRAM will be in the precharged (idle) state. A delay between the Auto Refresh Command (CBR) and the next Activate Command or subsequent Auto Refresh Command must be greater than or equal to the RAS cycle time (t_{RC}).

Self Refresh Command

The SDRAM device has a built-in timer to accommodate Self Refresh operation. The Self Refresh Command is defined by having $\overline{\text{CS}}$, $\overline{\text{RAS}}$, $\overline{\text{CAS}}$ and CKE held low with $\overline{\text{WE}}$ high at the rising edge of the clock. Once the Command is registered, CKE must be held low to keep the device in Self Refresh mode. When the SDRAM has entered Self Refresh mode all of the external control signals, except CKE , are disabled. The clock is internally disabled during Self Refresh Operation to save power. The user may halt the external clock while the device is in Self Refresh mode, however, the clock must be restarted before the device can exit Self Refresh operation. Once the clock is cycling, the device will exit Self Refresh operation on the second positive clock transition after CKE is returned high. A minimum delay time is required when the device exits Self Refresh Operation and before the next command can be issued. This delay is equal to the RAS cycle time (t_{RC}).

Data Mask

The SDRAM has a Data Mask function that can be used in conjunction with data read and write cycles. When the Data Mask is activated (DQM high) during a write cycle, the write operation is prohibited immediately (zero clock latency). If the Data Mask is activated during a read cycle, the data outputs are disabled and become high impedance after a two clock delay, independent of $\overline{\text{CAS}}$ latency.

Data Mask Activated During a Read Cycle (Burst Length = 4, $\overline{\text{CAS}}$ latency = 1)

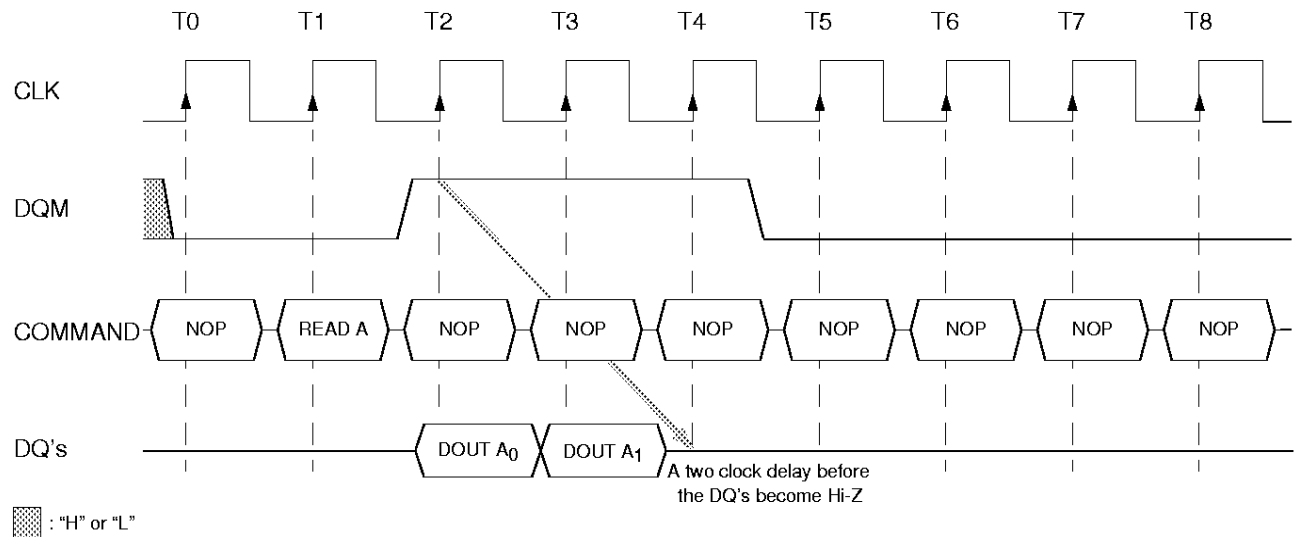

No Operation Command

The No Operation Command should be used in cases when the SDRAM is in a idle or a wait state. The purpose of the No Operation Command is to prevent the SDRAM from registering any unwanted commands between operations. A No Operation Command is registered when \overline{CS} is low with \overline{RAS} , \overline{CAS} , and \overline{WE} held high at the rising edge of the clock. A No Operation Command will not terminate a previous operation that is still executing, such as a burst read or write cycle.

Deselect Command

The Deselect Command performs the same function as a No Operation Command. Deselect Command occurs when \overline{CS} is brought high, the \overline{RAS} , \overline{CAS} , and \overline{WE} signals become don't cares.

Power Down Mode

In order to reduce standby power consumption, a power down mode is available. All banks must be pre-charged and the necessary Precharge delay (t_{RP}) must occur before the SDRAM can enter the Power Down mode. Once the Power Down mode is initiated by holding CKE low, all of the receiver circuits except CLK and CKE are gated off. The Power Down mode does not perform any refresh operations, therefore the device can't remain in Power Down mode longer than the Refresh period (t_{REF}) of the device.

The Power Down mode is exited by bringing CKE high. A one clock delay after the registration of CKE high is required for the SDRAM to exit the Power Down mode.

Clock Suspend Mode

During normal access mode, CKE is held high enabling the clock. When CKE is registered low while at least one of the banks is active, Clock Suspend Mode is entered. The Clock Suspend mode deactivates the internal clock and suspends or “freezes” any clocked operation that was currently being executed. There is a one clock delay between the registration of CKE low and the time at which the SDRAM’s operation suspends. While in Clock Suspend mode, the SDRAM ignores any new commands that are issued. The Clock Suspend mode is exited by bringing CKE high. There is a one clock cycle delay from when CKE returns high to when Clock Suspend mode is exited.

When the operation of the SDRAM is suspended during the execution of a Burst Read operation, the last valid data output onto the DQ pins will be actively held valid until Clock Suspend mode is exited.

Clock Suspend During a Read Cycle (Burst Length = 4, CAS latency = 2)

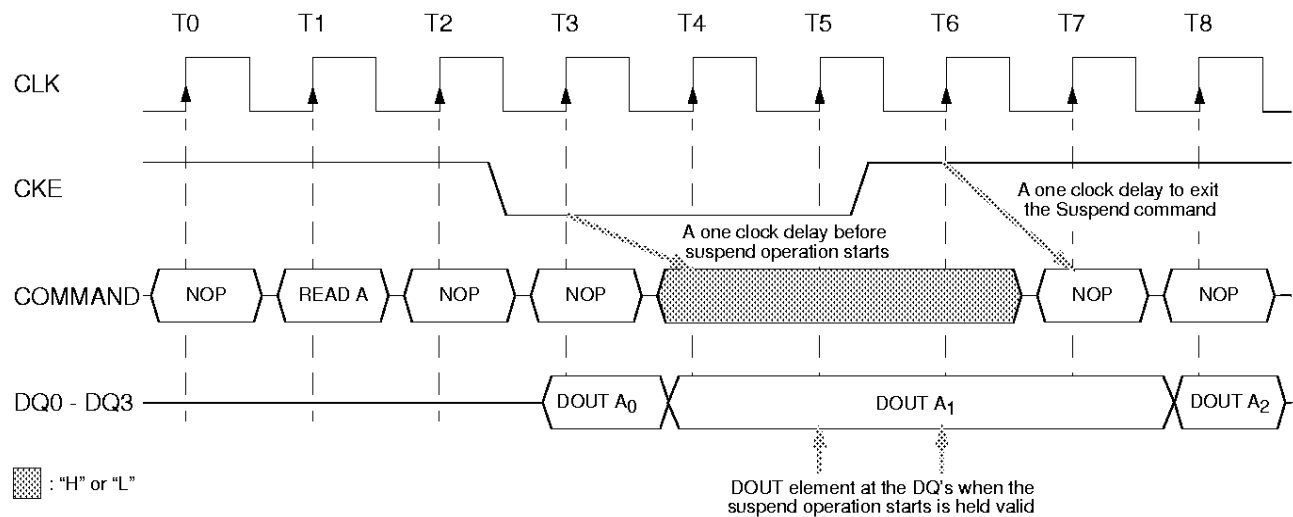

If Clock Suspend mode is initiated during a burst write operation, then the input data is masked and ignored until the Clock Suspend mode is exited.

Clock Suspend During a Write Cycle (Burst Length = 4, CAS latency = 2)

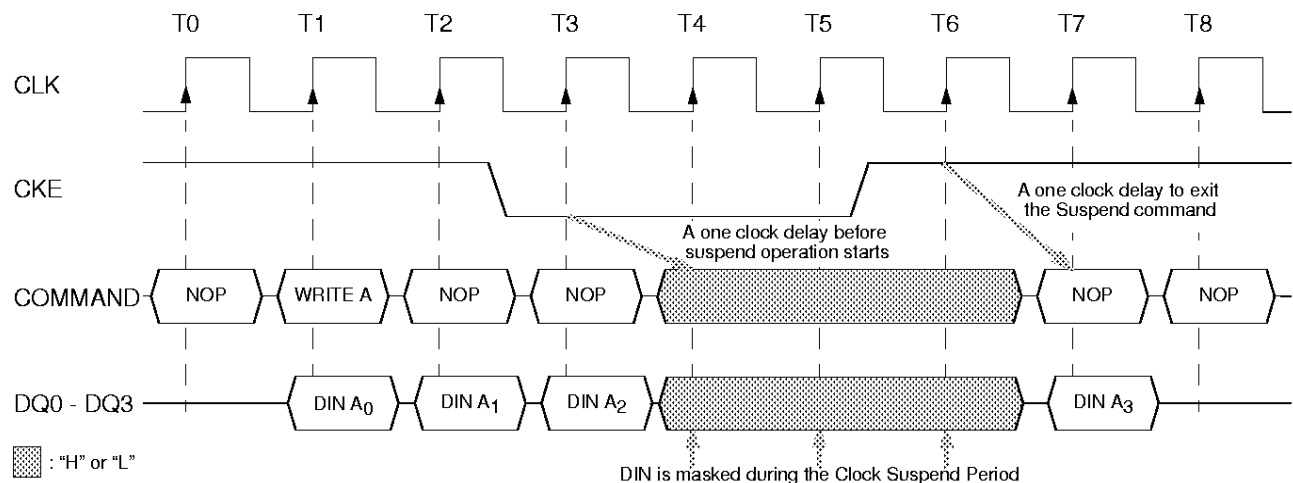



16Mb Synchronous DRAM

Command Truth Table (Notes: 1)

Function	CKE		\overline{CS}	\overline{RAS}	\overline{CAS}	\overline{WE}	DQM	A11	A10	A9 - A0	Notes
	Previous Cycle	Current Cycle									
Mode Register Set	H	X	L	L	L	L	X	OP Code			
Auto (CBR) Refresh	H	H	L	L	L	H	X	X	X	X	
Entry Self Refresh	H	L	L	L	L	H	X	X	X	X	
Single Bank Precharge	H	X	L	L	H	L	X	BS	L	X	2
Precharge all Banks	H	X	L	L	H	L	X	X	H	X	
Bank Activate	H	X	L	L	H	H	X	BS	Row Address		2
Write	H	X	L	H	L	L	X	BS	L	Column	2
Write with Auto-Precharge	H	X	L	H	L	L	X	BS	H	Column	2
Read	H	X	L	H	L	H	X	BS	L	Column	2
Read with Auto-Precharge	H	X	L	H	L	H	X	BS	H	Column	2
Burst Termination	H	X	L	H	H	L	X	X	X	X	3
No Operation	H	X	L	H	H	H	X	X	X	X	
Device Deselect	H	X	H	X	X	X	X	X	X	X	
Clock Suspend/Standby Mode	L	X	X	X	X	X	X	X	X	X	4
Data Write/Output Enable	H	X	X	X	X	X	L	X	X	X	5
Data Mask/Output Disable	H	X	X	X	X	X	H	X	X	X	5
Power Down Mode Entry	X	L	X	X	X	X	X	X	X	X	6,7
Power Down Mode Exit	X	H	X	X	X	X	X	X	X	X	6,7

1. All of the SDRAM operations are defined by states of \overline{CS} , \overline{WE} , \overline{RAS} , \overline{CAS} , and DQM at the positive rising edge of the clock.
2. Bank Select (BS), if BS = 0 then bank A is selected, if BS = 1 then bank B is selected.
3. During a Burst Write cycle there is a zero clock delay, for a Burst Read cycle the delay is equal to the \overline{CAS} latency.
4. During normal access mode, CKE is held high and CLK is enabled. When it is low, it freezes the internal clock and extends data Read and Write operations. One clock delay is required for mode entry and exit.
5. The DQM has two functions for the data DQ Read and Write operations. During a Read cycle, when DQM goes high at a clock timing the data outputs are disabled and become high impedance after a two clock delay. DQM also provides a data mask function for Write cycles. When it activates, the Write operation at the clock is prohibited (zero clock latency).
6. All banks must be precharged before entering the Power Down Mode. The Power Down Mode does not perform any refresh operations, therefore the device can't remain in this mode longer than the Refresh period (t_{REF}) of the device. One clock delay is required for mode entry and exit.
7. If \overline{CS} is low, then when CKE returns high, no command is registered into the chip for one clock cycle.



Clock Enable (CKE) Truth Table

Current State	CKE		Command						Action	Notes
	Previous Cycle	Current Cycle	\overline{CS}	\overline{RAS}	\overline{CAS}	\overline{WE}	A11	A10 - A0		
Self Refresh	H	X	X	X	X	X	X	X	INVALID	1
	L	H	H	X	X	X	X	X	Exit Self Refresh with Device Deselect	2
	L	H	L	H	H	H	X	X	Exit Self Refresh with No Operation	2
	L	H	L	H	H	L	X	X	ILLEGAL	2
	L	H	L	H	L	X	X	X	ILLEGAL	2
	L	H	L	L	X	X	X	X	ILLEGAL	2
	L	L	X	X	X	X	X	X	Maintain Self Refresh	
Power Down	H	X	X	X	X	X	X	X	INVALID	1
	L	H	H	X	X	X	X	X	Power Down mode exit, all banks idle	2
	L	H	L	X	X	X	X	X	ILLEGAL	2
	L	L	X	X	X	X	X	X	Maintain Power Down Mode	
All Banks Idle	H	H	H	X	X	X				3
	H	H	L	H	X	X			Refer to the Idle State section of the Current State Truth Table	3
	H	H	L	L	H	X				3
	H	H	L	L	L	H	X	X		CBR Refresh
	H	H	L	L	L	L		OP Code	Mode Register Set	4
	H	L	H	X	X	X				3
	H	L	L	H	X	X			Refer to the Idle State section of the Current State Truth Table	3
	H	L	L	L	H	X				3
	H	L	L	L	L	H	X	X	Entry Self Refresh	4
	H	L	L	L	L	L		OP Code	Mode Register Set	
L	X	X	X	X	X	X	X	Power Down	4	
Any State other than listed above	H	H	X	X	X	X	X	X	Refer to operations in the Current State Truth Table	
	H	L	X	X	X	X	X	X		Begin Clock Suspend next cycle
	L	H	X	X	X	X	X	X	Exit Clock Suspend next cycle	
	L	L	X	X	X	X	X	X	Maintain Clock Suspend	

1. For the given Current State CKE must be low in the previous cycle.
2. When CKE has a low to high transition, the clock and other inputs are re-enabled asynchronously. The minimum setup time for CKE (t_{CES}) must be satisfied before any command other than Exit is issued.
3. The address inputs (A11 - A0) depend on the command that is issued. See the Idle State section of the Current State Truth Table for more information.
4. The Power Down Mode, Self Refresh Mode, and the Mode Register Set can only be entered from the all banks idle state.
5. Must be a legal command as defined in the Current State Truth Table.



16Mb Synchronous DRAM

Current State Truth Table (Notes: 1)

Current State	Command						Description	Action	Notes
	CS	RAS	CAS	WE	A11	A10 - A0			
Idle	L	L	L	L		OP Code	Mode Register Set	Set the Mode Register	2
	L	L	L	H	X	X	Auto or Self Refresh	Start Auto or Self Refresh	2, 3
	L	L	H	L	BS	X	Precharge	No Operation	
	L	L	H	H	BS	Row Address	Bank Activate	Activate the specified bank and row	
	L	H	L	L	BS	Column	Write w/o Precharge	ILLEGAL	4
	L	H	L	H	BS	Column	Read w/o Precharge	ILLEGAL	4
	L	H	H	L	X	X	Burst Termination	No Operation	
	L	H	H	H	X	X	No Operation	No Operation	
	H	X	X	X	X	X	Device Deselect	No Operation or Power Down	5
Row Active	L	L	L	L		OP Code	Mode Register Set	ILLEGAL	
	L	L	L	H	X	X	Auto or Self Refresh	ILLEGAL	
	L	L	H	L	BS	X	Precharge	Precharge	6
	L	L	H	H	BS	Row Address	Bank Activate	ILLEGAL	4
	L	H	L	L	BS	Column	Write	Start Write; Determine if Auto Precharge	7, 8
	L	H	L	H	BS	Column	Read	Start Read; Determine if Auto Precharge	7, 8
	L	H	H	L	X	X	Burst Termination	No Operation	
	L	H	H	H	X	X	No Operation	No Operation	
	H	X	X	X	X	X	Device Deselect	No Operation	
Read	L	L	L	L		OP Code	Mode Register Set	ILLEGAL	
	L	L	L	H	X	X	Auto or Self Refresh	ILLEGAL	
	L	L	H	L	BS	X	Precharge	Terminate Burst; Start the Precharge	
	L	L	H	H	BS	Row Address	Bank Activate	ILLEGAL	4
	L	H	L	L	BS	Column	Write	Terminate Burst; Start the Write cycle	8, 9
	L	H	L	H	BS	Column	Read	Terminate Burst; Start a new Read cycle	8, 9
	L	H	H	L	X	X	Burst Termination	Terminate the Burst	
	L	H	H	H	X	X	No Operation	Continue the Burst	
	H	X	X	X	X	X	Device Deselect	Continue the Burst	

1. CKE is assumed to be active (high) in the previous cycle for all entries. The Current State is the state of the bank that the Command is being applied to.
2. Both Banks must be idle otherwise it is an illegal action.
3. If CKE is active (high) the SDRAM will start the Auto (CBR) Refresh operation, if CKE is inactive (low) than the Self Refresh mode is entered.
4. The Current State refers only refers to one of the banks, if BS selects this bank then the action is illegal. If BS selects the bank not being referenced by the Current State then the action may be legal depending on the state of that bank.
5. If CKE is inactive (low) than the Power Down mode is entered, otherwise there is a No Operation.
6. The minimum and maximum Active time (t_{RAS}) must be satisfied.
7. The \overline{RAS} to \overline{CAS} Delay (t_{RCD}) must occur before the command is given.
8. Column address A10 is used to determine if the Auto Precharge function is activated.
9. The command must satisfy any bus contention, bus turn around, and/or write recovery requirements.
10. The command is illegal if the minimum bank to bank delay time (t_{RRD}) is not satisfied.



Current State Truth Table (Continued) (Notes: 1)

Current State	Command							Action	Notes
	CS	RAS	CAS	WE	A11	A10 - A0	Description		
Write	L	L	L	L		OP Code	Mode Register Set	ILLEGAL	
	L	L	L	H	X	X	Auto or Self Refresh	ILLEGAL	
	L	L	H	L	BS	X	Precharge	Terminate Burst; Start the Precharge	
	L	L	H	H	BS	Row Address	Bank Activate	ILLEGAL	4
	L	H	L	L	BS	Column	Write	Terminate Burst; Start a new Write cycle	8, 9
	L	H	L	H	BS	Column	Read	Terminate Burst; Start the Read cycle	8, 9
	L	H	H	L	X	X	Burst Termination	Terminate the Burst	
	L	H	H	H	X	X	No Operation	Continue the Burst	
	H	X	X	X	X	X	Device Deselect	Continue the Burst	
Read with Auto Precharge	L	L	L	L		OP Code	Mode Register Set	ILLEGAL	
	L	L	L	H	X	X	Auto or Self Refresh	ILLEGAL	
	L	L	H	L	BS	X	Precharge	ILLEGAL	4
	L	L	H	H	BS	Row Address	Bank Activate	ILLEGAL	4
	L	H	L	L	BS	Column	Write	ILLEGAL	
	L	H	L	H	BS	Column	Read	ILLEGAL	
	L	H	H	L	X	X	Burst Termination	ILLEGAL	
	L	H	H	H	X	X	No Operation	Continue the Burst	
	H	X	X	X	X	X	Device Deselect	Continue the Burst	
Write with Auto Precharge	L	L	L	L		OP Code	Mode Register Set	ILLEGAL	
	L	L	L	H	X	X	Auto or Self Refresh	ILLEGAL	
	L	L	H	L	BS	X	Precharge	ILLEGAL	4
	L	L	H	H	BS	Row Address	Bank Activate	ILLEGAL	4
	L	H	L	L	BS	Column	Write	ILLEGAL	
	L	H	L	H	BS	Column	Read	ILLEGAL	
	L	H	H	L	X	X	Burst Termination	ILLEGAL	
	L	H	H	H	X	X	No Operation	Continue the Burst	
	H	X	X	X	X	X	Device Deselect	Continue the Burst	

1. CKE is assumed to be active (high) in the previous cycle for all entries. The Current State is the state of the bank that the Command is being applied to.
2. Both Banks must be idle otherwise it is an illegal action.
3. If CKE is active (high) the SDRAM will start the Auto (CBR) Refresh operation, if CKE is inactive (low) than the Self Refresh mode is entered.
4. The Current State refers only refers to one of the banks, if BS selects this bank then the action is illegal. If BS selects the bank not being referenced by the Current State then the action may be legal depending on the state of that bank.
5. If CKE is inactive (low) than the Power Down mode is entered, otherwise there is a No Operation.
6. The minimum and maximum Active time (t_{RAS}) must be satisfied.
7. The \overline{RAS} to \overline{CAS} Delay (t_{RCD}) must occur before the command is given.
8. Column address A10 is used to determine if the Auto Precharge function is activated.
9. The command must satisfy any bus contention, bus turn around, and/or write recovery requirements.
10. The command is illegal if the minimum bank to bank delay time (t_{RRD}) is not satisfied.



16Mb Synchronous DRAM

Current State Truth Table (Continued) (Notes: 1)

Current State	Command							Action	Notes
	CS	RAS	CAS	WE	A11	A10 - A0	Description		
Precharging	L	L	L	L		OP Code	Mode Register Set	ILLEGAL	
	L	L	L	H	X	X	Auto or Self Refresh	ILLEGAL	
	L	L	H	L	BS	X	Precharge	No Operation; Bank(s) idle after t _{RP}	
	L	L	H	H	BS	Row Address	Bank Activate	ILLEGAL	4
	L	H	L	L	BS	Column	Write	ILLEGAL	4
	L	H	L	H	BS	Column	Read	ILLEGAL	4
	L	H	H	L	X	X	Burst Termination	No Operation; Bank(s) idle after t _{RP}	
	L	H	H	H	X	X	No Operation	No Operation; Bank(s) idle after t _{RP}	
	H	X	X	X	X	X	Device Deselect	No Operation; Bank(s) idle after t _{RP}	
Row Activating	L	L	L	L		OP Code	Mode Register Set	ILLEGAL	
	L	L	L	H	X	X	Auto or Self Refresh	ILLEGAL	
	L	L	H	L	BS	X	Precharge	ILLEGAL	4
	L	L	H	H	BS	Row Address	Bank Activate	ILLEGAL	4, 10
	L	H	L	L	BS	Column	Write	ILLEGAL	4
	L	H	L	H	BS	Column	Read	ILLEGAL	4
	L	H	H	L	X	X	Burst Termination	No Operation; Row Active after t _{RCD}	
	L	H	H	H	X	X	No Operation	No Operation; Row Active after t _{RCD}	
	H	X	X	X	X	X	Device Deselect	No Operation; Row Active after t _{RCD}	
Write Recovering	L	L	L	L		OP Code	Mode Register Set	ILLEGAL	
	L	L	L	H	X	X	Auto or Self Refresh	ILLEGAL	
	L	L	H	L	BS	X	Precharge	ILLEGAL	4
	L	L	H	H	BS	Row Address	Bank Activate	ILLEGAL	4
	L	H	L	L	BS	Column	Write	Start Write; Determine if Auto Precharge	9
	L	H	L	H	BS	Column	Read	Start Read; Determine if Auto Precharge	9
	L	H	H	L	X	X	Burst Termination	No Operation; Row Active after t _{DPL}	
	L	H	H	H	X	X	No Operation	No Operation; Row Active after t _{DPL}	
	H	X	X	X	X	X	Device Deselect	No Operation; Row Active after t _{DPL}	

1. CKE is assumed to be active (high) in the previous cycle for all entries. The Current State is the state of the bank that the Command is being applied to.
2. Both Banks must be idle otherwise it is an illegal action.
3. If CKE is active (high) the SDRAM will start the Auto (CBR) Refresh operation, if CKE is inactive (low) than the Self Refresh mode is entered.
4. The Current State refers only refers to one of the banks, if BS selects this bank then the action is illegal. If BS selects the bank not being referenced by the Current State then the action may be legal depending on the state of that bank.
5. If CKE is inactive (low) than the Power Down mode is entered, otherwise there is a No Operation.
6. The minimum and maximum Active time (t_{RAS}) must be satisfied.
7. The RAS to CAS Delay (t_{RCD}) must occur before the command is given.
8. Column address A10 is used to determine if the Auto Precharge function is activated.
9. The command must satisfy any bus contention, bus turn around, and/or write recovery requirements.
10. The command is illegal if the minimum bank to bank delay time (t_{RRD}) is not satisfied.



Current State Truth Table (Continued) (Notes: 1)

Current State	Command						Description	Action	Notes
	CS	RAS	CAS	WE	A11	A10 - A0			
Write Recovering with Auto Precharge	L	L	L	L		OP Code	Mode Register Set	ILLEGAL	
	L	L	L	H	X	X	Auto or Self Refresh	ILLEGAL	
	L	L	H	L	BS	X	Precharge	ILLEGAL	4
	L	L	H	H	BS	Row Address	Bank Activate	ILLEGAL	4
	L	H	L	L	BS	Column	Write	ILLEGAL	4, 9
	L	H	L	H	BS	Column	Read	ILLEGAL	4, 9
	L	H	H	L	X	X	Burst Termination	No Operation; Precharge after t _{DPL}	
	L	H	H	H	X	X	No Operation	No Operation; Precharge after t _{DPL}	
Refreshing	H	X	X	X	X	X	Device Deselect	No Operation; Precharge after t _{DPL}	
	L	L	L	L		OP Code	Mode Register Set	ILLEGAL	
	L	L	L	H	X	X	Auto or Self Refresh	ILLEGAL	
	L	L	H	L	BS	X	Precharge	ILLEGAL	
	L	L	H	H	BS	Row Address	Bank Activate	ILLEGAL	
	L	H	L	L	BS	Column	Write	ILLEGAL	
	L	H	L	H	BS	Column	Read	ILLEGAL	
	L	H	H	L	X	X	Burst Termination	No Operation; Idle after t _{RC}	
Mode Register Accessing	L	H	H	H	X	X	No Operation	No Operation; Idle after t _{RC}	
	H	X	X	X	X	X	Device Deselect	No Operation; Idle after t _{RC}	
	L	L	L	L		OP Code	Mode Register Set	ILLEGAL	
	L	L	L	H	X	X	Auto or Self Refresh	ILLEGAL	
	L	L	H	L	BS	X	Precharge	ILLEGAL	
	L	L	H	H	BS	Row Address	Bank Activate	ILLEGAL	
	L	H	L	L	BS	Column	Write	ILLEGAL	
	L	H	L	H	BS	Column	Read	ILLEGAL	
	L	H	H	L	X	X	Burst Termination	ILLEGAL	
	L	H	H	H	X	X	No Operation	No Operation; Idle after two clock cycles	
	H	X	X	X	X	X	Device Deselect	No Operation; Idle after two clock cycles	

1. CKE is assumed to be active (high) in the previous cycle for all entries. The Current State is the state of the bank that the Command is being applied to.
2. Both Banks must be idle otherwise it is an illegal action.
3. If CKE is active (high) the SDRAM will start the Auto (CBR) Refresh operation, if CKE is inactive (low) than the Self Refresh mode is entered.
4. The Current State refers only refers to one of the banks, if BS selects this bank then the action is illegal. If BS selects the bank not being referenced by the Current State then the action may be legal depending on the state of that bank.
5. If CKE is inactive (low) than the Power Down mode is entered, otherwise there is a No Operation.
6. The minimum and maximum Active time (t_{RAS}) must be satisfied.
7. The RAS to CAS Delay (t_{RCd}) must occur before the command is given.
8. Column address A10 is used to determine if the Auto Precharge function is activated.
9. The command must satisfy any bus contention, bus turn around, and/or write recovery requirements.
10. The command is illegal if the minimum bank to bank delay time (t_{RRD}) is not satisfied.

16Mb Synchronous DRAM

Absolute Maximum Ratings

Symbol	Parameter	Rating	Units	Notes
VDD	Power Supply Voltage	-1.0 to +4.6	V	1
VDDQ	Power Supply Voltage for Output	-1.0 to +4.6	V	1
V _{IN}	Input Voltage	-1.0 to +4.6	V	1
V _{OUT}	Output Voltage	-1.0 to +4.6	V	1
T _A	Operating Temperature (ambient)	0 to +70	°C	1
T _{STG}	Storage Temperature	-55 to +125	°C	1
P _D	Power Dissipation	1.0	W	1
I _{OUT}	Short Circuit Output Current	50	mA	1

1. Stresses greater than those listed under "Absolute Maximum Ratings" may cause permanent damage to the device. This is a stress rating only and functional operation of the device at these or any other conditions above those indicated in the operational sections of this specification is not implied. Exposure to absolute maximum rating conditions for extended periods may affect reliability.

Recommended DC Operating Conditions (T_A= 0 to 70°C)

Symbol	Parameter	Rating			Units	Notes
		Min.	Typ.	Max.		
VDD	Supply Voltage	3.0	3.3	3.6	V	1
VDDQ	Supply Voltage for Output	3.0	3.3	3.6	V	1
V _{IH}	Input High Voltage	2.0	—	VDD + 0.3	V	1
V _{IL}	Input Low Voltage	-0.3	—	0.8	V	1

1. All voltages referenced to V_{SS} and VSSQ.

Capacitance (T_A= 25°C, f=1MHz, V_{DD}= 3.3V ± 0.3V)

Symbol	Parameter	Min.	Typ.	Max.	Units	Notes
C _{I1}	Input Capacitance (A0 - A11)	2.0	2.7	4.0	pF	
C _{I2}	Input Capacitance (RAS, CAS, WE, CS, CLK, CKE, DQM)	2.0	2.7	4.0	pF	
C _O	Output Capacitance (DQ0 - DQ15)	2.0	4.0	5.0	pF	

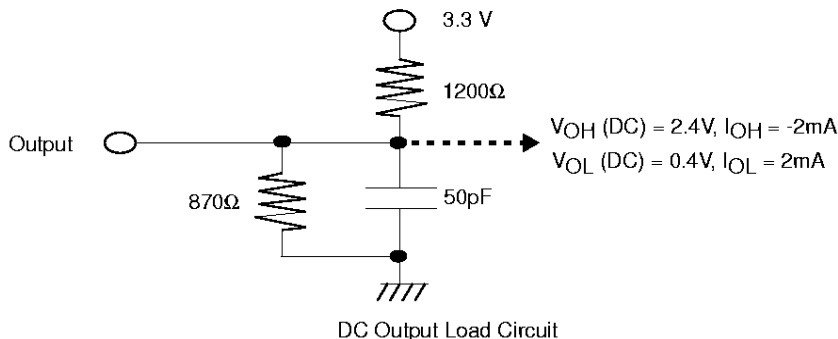



Output Characteristics ($T_A = 0$ to $+70^\circ\text{C}$, $V_{DD} = 3.3\text{V} \pm 0.3\text{V}$)

Symbol	Parameter	Min.	Max.	Units	Notes
$I_{(L)}$	Input Leakage Current, any input ($0.0\text{V} \leq V_{IN} \leq 3.6\text{V}$), All Other Pins Not Under Test = 0V	-1	+1	μA	
$I_{(OL)}$	Output Leakage Current (D_{OUT} is disabled, $0.0\text{V} \leq V_{OUT} \leq 3.6\text{V}$)	-1	+1	μA	
V_{OH}	Output Level (TTL) Output "H" Level Voltage ($I_{OUT} = -2.0\text{mA}$)	2.4	VDDQ	V	1
V_{OL}	Output Level (TTL) Output "L" Level Voltage ($I_{OUT} = +2.0\text{mA}$)	0.0	0.4	V	1

1. See DC output load circuit.

Standby and Refresh Currents ($T_A = 0$ to $+70^\circ\text{C}$, $V_{DD} = 3.3\text{V} \pm 0.3\text{V}$)

Parameter	Symbol	Test Condition	Organization			Units	Notes	
			X4	X8	X16			
Precharge Standby Current in Power Down Mode	I_{CC1P}	$\text{CKE} \leq V_{IL}(\text{max})$, $t_{CK} = 15\text{ns}$	3	3	3	mA		
	I_{CC1PS}	$\text{CKE} \leq V_{IL}(\text{max})$, $t_{CK} = \text{Infinity}$	2	2	2	mA		
Precharge Standby Current in Non-Power Down Mode	I_{CC1N}	$\text{CKE} \geq V_{IH}(\text{min})$, $t_{CK} = 15\text{ns}$ Input Change every 30ns	30	30	30	mA	$\overline{\text{CS}} = \text{High}$	
	I_{CC1NS}	$\text{CKE} \geq V_{IH}(\text{min})$, $t_{CK} = \text{Infinity}$ No Input Change	15	15	15	mA		
Active Standby Current in Power Down Mode	I_{CC2P}	$\text{CKE} \leq V_{IL}(\text{max})$, $t_{CK} = 15\text{ns}$	3	3	3	mA		
	I_{CC2PS}	$\text{CKE} \leq V_{IL}(\text{max})$, $t_{CK} = \text{Infinity}$	2	2	2	mA		
Active Standby Current in Non-Power Down Mode	I_{CC2N}	$\text{CKE} \geq V_{IH}(\text{min})$, $t_{CK} = 15\text{ns}$ Input Change every 30ns	30	30	30	mA	$\overline{\text{CS}} = \text{High}$	
	I_{CC2NS}	$\text{CKE} \geq V_{IH}(\text{min})$, $t_{CK} = \text{Infinity}$ No Input Change	20	20	20	mA		
Auto (CBR) Refresh Current	I_{CC3}	$\overline{\text{CAS}}$ Latency = 1 $t_{RC} \geq t_{RC}(\text{min})$	-10	85	85	85	mA	1,2,3
			-12	75	75	75		
		$\overline{\text{CAS}}$ Latency = 2 $t_{RC} \geq t_{RC}(\text{min})$	-10	105	105	105	mA	
			-12	90	90	90		
		$\overline{\text{CAS}}$ Latency = 3 $t_{RC} \geq t_{RC}(\text{min})$	-10	125	125	125	mA	
			-12	110	110	110		
Self Refresh Current	I_{CC4}	$\text{CKE} \leq 0.2\text{V}$	2	2	2	mA		

1. The specified values are valid when addresses are changed no more than once during $t_{CK}(\text{min})$.
2. The specified values are valid when No Operation commands are registered on every rising clock edge during $t_{RC}(\text{min})$.
3. The specified values are valid when data inputs (DQ's) are stable during $t_{RC}(\text{min})$.



16Mb Synchronous DRAM

Operating Currents ($T_A = 0$ to $+70^\circ\text{C}$, $V_{DD} = 3.3\text{V} \pm 0.3\text{V}$)

Symbol	Parameter	Test Condition	CAS Latency	$t_{RC}(\text{min})$	Speed Sort	Organization			Units	Notes
						X4	X8	X16		
I_{CC5}	Operating Current Burst Length = 1	$t_{RC} = t_{RC}(\text{min})$ $t_{CK} \geq t_{CK}(\text{min})$ $I_O = 0\text{mA}$	CL=1	90 ns	-10	95	95	95	mA	1, 2
				108 ns	-12	80	80	85		
			CL=2	75 ns	-10	125	125	130	mA	
				90 ns	-12	110	110	115		
			CL=3	80 ns	-10	140	140	145	mA	
				96 ns	-12	120	120	125		
I_{CC6}	Operating Current Burst Length = 2	$t_{RC} = t_{RC}(\text{min})$ $t_{CK} \geq t_{CK}(\text{min})$ $I_O = 0\text{mA}$	CL=1	120 ns	-10	75	75	80	mA	1, 2, 3
				144 ns	-12	65	65	70		
			CL=2	90 ns	-10	115	115	120	mA	
				108 ns	-12	100	100	105		
			CL=3	90 ns	-10	140	140	145	mA	
				108 ns	-12	120	120	125		
I_{CC7}	Operating Current Burst Length = 4	$t_{RC} = t_{RC}(\text{min})$ $t_{CK} \geq t_{CK}(\text{min})$ $I_O = 0\text{mA}$	CL=1	180 ns	-10	65	65	70	mA	1, 2, 3
				216 ns	-12	55	55	60		
			CL=2	120 ns	-10	100	105	110	mA	
				144 ns	-12	85	90	95		
			CL=3	110 ns	-10	130	135	140	mA	
				132 ns	-12	115	120	125		
I_{CC8}	Operating Current Burst Length = 8	$t_{RC} = t_{RC}(\text{min})$ $t_{CK} \geq t_{CK}(\text{min})$ $I_O = 0\text{mA}$	CL=1	300 ns	-10	55	60	65	mA	1, 2, 3
				360 ns	-12	45	50	55		
			CL=2	180 ns	-10	90	95	105	mA	
				216 ns	-12	80	85	95		
			CL=3	150 ns	-10	125	130	140	mA	
				180 ns	-12	105	110	120		
I_{CC9}	Operating Current Burst Length = Full Page	$t_{RC} = \text{Infinity}$ $t_{CK} \geq t_{CK}(\text{min})$ $I_O = 0\text{mA}$	CL=1	$t_{RC} = \infty$ $t_{CK} = 30 \text{ ns}$	-10	40	45	55	mA	1, 2, 3
				$t_{RC} = \infty$ $t_{CK} = 36 \text{ ns}$	-12	35	40	45		
			CL=2	$t_{RC} = \infty$ $t_{CK} = 15 \text{ ns}$	-10	70	75	90	mA	
				$t_{RC} = \infty$ $t_{CK} = 18 \text{ ns}$	-12	60	65	80		
			CL=3	$t_{RC} = \infty$ $t_{CK} = 10 \text{ ns}$	-10	100	105	135	mA	
				$t_{RC} = \infty$ $t_{CK} = 12 \text{ ns}$	-12	85	95	120		

1. The specified values are obtained with the output open.
2. The specified values are valid when addresses and DQ's are changed no more than once during $t_{CK}(\text{min})$.
3. The specified values are obtained when the programmed burst length is executed to completion without interruption by a subsequent burst Read or Write cycle.



Operating Currents ($T_A = 0$ to $+70^\circ\text{C}$, $V_{DD} = 3.3\text{V} \pm 0.3\text{V}$)

Symbol	Parameter	Test Condition	$\overline{\text{CAS}}$ Latency	$t_{RC}(\text{min})$	Speed Sort	Organization			Units	Notes
						X4	X8	X16		
I_{CC10}	Operating Current 1-N Rule (Continuous Read/Write cycles with new column address registered each clock cycle)	$t_{RC} = \text{Infinity}$ $t_{CK} \geq t_{CK}(\text{min})$ $I_O = 0\text{mA}$	CL=1	$t_{RC} = \infty$ $t_{CK} = 30 \text{ ns}$	-10	85	85	90	mA	1, 2
				$t_{RC} = \infty$ $t_{CK} = 36 \text{ ns}$	-12	80	80	85		
			CL=2	$t_{RC} = \infty$ $t_{CK} = 15 \text{ ns}$	-10	130	130	140	mA	
				$t_{RC} = \infty$ $t_{CK} = 18 \text{ ns}$	-12	115	115	120		
			CL=3	$t_{RC} = \infty$ $t_{CK} = 10 \text{ ns}$	-10	175	175	190	mA	
				$t_{RC} = \infty$ $t_{CK} = 12 \text{ ns}$	-12	150	150	165		

1. The specified values are obtained with the output open.
2. The specified values are valid when addresses and DQ's are changed no more than once during $t_{CK}(\text{min})$.
3. The specified values are obtained when the programmed burst length is executed to completion without interruption by a subsequent burst Read or Write cycle.

16Mb Synchronous DRAM

AC Characteristics ($T_A = 0$ to $+70^\circ\text{C}$, $V_{DD} = 3.3\text{V} \pm 0.3\text{V}$)

1. An initial pause of $100\mu\text{s}$ is required after power-up, then a Precharge All Banks command must be given followed by a minimum of two Auto (CBR) Refresh cycles before the Mode Register Set operation can begin.
2. AC timing tests have $V_{IL} = 0.8\text{V}$ and $V_{IH} = 2.0\text{V}$ with the timing referenced to the 1.4V crossover point.

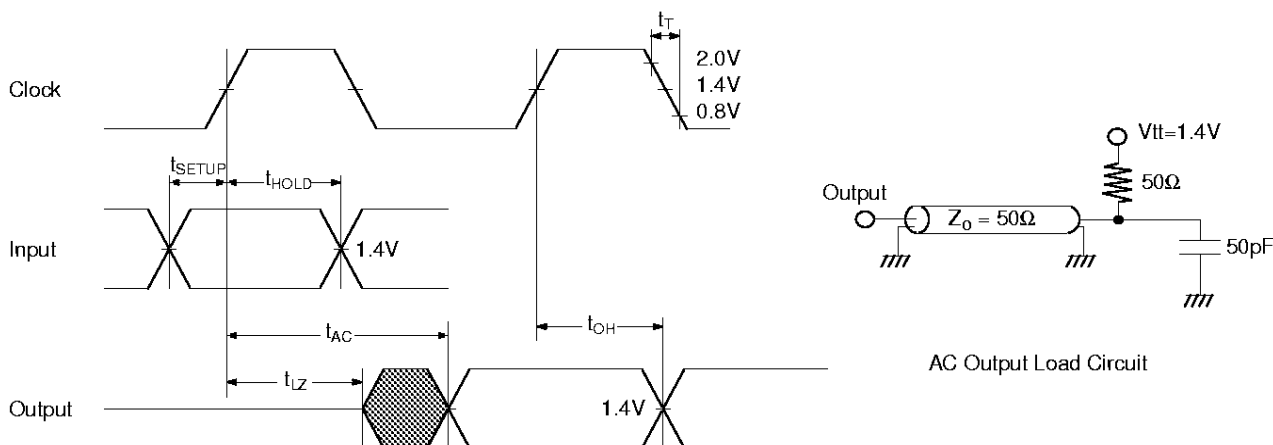

3. The Transition time is measured between V_{IH} and V_{IL} (or between V_{IL} and V_{IH}).
4. AC measurements assume $t_T = 1\text{ns}$.
5. In addition to meeting the transition rate specification, the clock and CKE must transit between V_{IH} and V_{IL} (or between V_{IL} and V_{IH}) in a monotonic manner.

Clock and Clock Enable Parameters

Symbol	Parameter	-10		-12		Units	Notes
		Min.	Max.	Min.	Max.		
t_{CK3}	Clock Cycle Time, $\overline{\text{CAS}}$ Latency = 3	10	100MHz	12	83MHz	ns	
t_{CK2}	Clock Cycle Time, $\overline{\text{CAS}}$ Latency = 2	15	66MHz	18	56MHz	ns	
t_{CK1}	Clock Cycle Time, $\overline{\text{CAS}}$ Latency = 1	30	33MHz	36	28MHz	ns	
t_{AC3}	Clock Access Time, $\overline{\text{CAS}}$ Latency = 3	—	8	—	9	ns	1,2
t_{AC2}	Clock Access Time, $\overline{\text{CAS}}$ Latency = 2	—	9	—	10	ns	1,2
t_{AC1}	Clock Access Time, $\overline{\text{CAS}}$ Latency = 1	—	27	—	27	ns	1,2
t_{CKH}	Clock High Pulse Width	3.5	—	4	—	ns	3
t_{CKL}	Clock Low Pulse Width	3.5	—	4	—	ns	3
t_{CES}	Clock Enable Set-up Time	3	—	3	—	ns	
t_{CEH}	Clock Enable Hold Time	1	—	1	—	ns	
t_{CESP}	CKE Set-up Time (Power down mode)	3	—	3	—	ns	
t_T	Transition Time (Rise and Fall)	1	30	1	30	ns	

1. Access time is measured at 1.4V . See AC output load circuit.
2. Access time is measured assuming a clock rise time of 1ns . If clock rise time is longer than 1ns , then $(\text{trise}/2-0.5)\text{ns}$ should be added to the parameter.
3. Assumes clock rise and fall times are equal to 1ns . If rise or fall time exceeds 1ns , then other AC parameters under consideration should be compensated by an additional $[(\text{trise}+\text{tfall})/2-1]\text{ns}$.



Common Parameters

Symbol	Parameter	-10		-12		Units	Notes
		Min.	Max.	Min.	Max.		
t_{CS}	Command Setup Time	3	—	3	—	ns	
t_{CH}	Command Hold Time	1	—	1	—	ns	
t_{AS}	Address and Bank Select Set-up Time	3	—	3	—	ns	
t_{AH}	Address and Bank Select Hold Time	1	—	1	—	ns	
t_{RCD}	RAS to CAS Delay	30	—	30	—	ns	
t_{RC}	Bank Cycle Time	75	120000	96	120000	ns	
t_{RAS}	Active Command Period	45	120000	60	120000	ns	
t_{RP}	Precharge Time	30	—	30	—	ns	
t_{RRD}	Bank to Bank Delay Time	20	—	24	—	ns	
t_{CCD}	CAS to CAS Delay Time (Same Bank)	1	—	1	—	CLK	

Refresh Cycle

Symbol	Parameter	-10		-12		Units	Notes
		Min.	Max.	Min.	Max.		
t_{SREX}	Self Refresh Exit Time	$2CLK+t_{RC}$	—	$2CLK+t_{RC}$	—	ns	3
t_{REF}	Refresh Period	—	64	—	64	ms	1, 2

- 4096 cycles.
- Any time that the Refresh Period has been exceeded, a minimum of two Auto (CBR) Refresh commands must be given to "wake-up" the device.
- Self Refresh Exit is a synchronous operation and begins on the 2nd positive clock edge after CKE returns high. Self Refresh Exit is not complete until a time period equal to t_{RC} is satisfied once the Self Refresh Exit command is registered.

Read Cycle

Symbol	Parameter	-10		-12		Units	Notes
		Min.	Max.	Min.	Max.		
t_{OH}	Data Out Hold Time	3	—	3	—	ns	
t_{LZ}	Data Out to Low Impedance Time	3	—	3	—	ns	
t_{HZ3}	Data Out to High Impedance Time, CL= 3	3	8	3	8	ns	1
t_{HZ2}	Data Out to High Impedance Time, CL= 2	3	8	3	10	ns	1
t_{HZ1}	Data Out to High Impedance Time, CL= 1	3	15	3	18	ns	1
t_{DQZ}	DQM Data Out Disable Latency	2	—	2	—	CLK	

- Referenced to the time at which the output achieves the open circuit condition, not to output voltage levels.



16Mb Synchronous DRAM

Write Cycle

Symbol	Parameter	-10		-12		Units	Notes
		Min.	Max.	Min.	Max.		
t_{DS}	Data In Set-up Time	3	—	3	—	ns	
t_{DH}	Data In Hold Time	1	—	1	—	ns	
t_{DPL}	Data input to Precharge	15	—	15	—	ns	
t_{DQW}	DQM Write Mask Latency	0	—	0	—	CLK	

Clock Frequency and Latency

Symbol	Parameter	Speed Sort						Units	Notes
		-10			-12				
f_{CK}	Clock Frequency	100	66	33	83	56	28	MHz	
t_{CK}	Clock Cycle Time	10	15	30	12	18	36	ns	
t_{AA}	\overline{CAS} Latency	3	2	1	3	2	1	CLK	
t_{RCD}	\overline{RAS} to \overline{CAS} Delay	3	2	1	3	2	1	CLK	
t_{RL}	\overline{RAS} Latency	6	4	2	6	4	2	CLK	
t_{RC}	Bank Cycle Time	8	5	3	8	5	3	CLK	
t_{RAS}	Minimum Bank Active Time	5	3	2	5	3	2	CLK	
t_{RP}	Precharge Time	3	2	1	3	2	1	CLK	
t_{DPL}	Data In to Precharge	2	1	1	2	1	1	CLK	
t_{DAL}	Data In to Active/Refresh	5	3	2	5	3	2	CLK	
t_{RRD}	Bank to Bank Delay Time	2	2	1	2	2	1	CLK	
t_{CCD}	\overline{CAS} to \overline{CAS} Delay Time	1	1	1	1	1	1	CLK	
t_{WL}	Write Latency	0	0	0	0	0	0	CLK	
t_{DQW}	DQM Write Mask Latency	0	0	0	0	0	0	CLK	
t_{DQZ}	DQM Data Disable Latency	2	2	2	2	2	2	CLK	
t_{CSL}	Clock Suspend Latency	1	1	1	1	1	1	CLK	



Timing Diagrams	Page
AC Parameters for Write Timing.....	43
AC Parameters for Read Timing	44
Mode Register Set.....	45
Power on Sequence and Auto Refresh (CBR)	46
Clock Suspension During a Burst Read (Using CKE)	
$\overline{\text{CAS}}$ Latency = 1	47
$\overline{\text{CAS}}$ Latency = 2.....	48
$\overline{\text{CAS}}$ Latency = 3.....	49
Clock Suspension During a Burst Write (Using CKE)	
$\overline{\text{CAS}}$ Latency = 1	50
$\overline{\text{CAS}}$ Latency = 2.....	51
$\overline{\text{CAS}}$ Latency = 3.....	52
Power Down Mode and Clock Suspend	53
Auto Refresh (CBR).....	54
Self Refresh (Entry and Exit)	55
Random Column Read (Page within same Bank)	
$\overline{\text{CAS}}$ Latency = 1	56
$\overline{\text{CAS}}$ Latency = 2.....	57
$\overline{\text{CAS}}$ Latency = 3.....	58
Random Column Write (Page within same Bank)	
$\overline{\text{CAS}}$ Latency = 1	59
$\overline{\text{CAS}}$ Latency = 2.....	60
$\overline{\text{CAS}}$ Latency = 3.....	61
Random Row Read (Interleaving Banks)	
$\overline{\text{CAS}}$ Latency = 1	62
$\overline{\text{CAS}}$ Latency = 2.....	63
$\overline{\text{CAS}}$ Latency = 3.....	64
Random Row Write (Interleaving Banks)	
$\overline{\text{CAS}}$ Latency = 1	65
$\overline{\text{CAS}}$ Latency = 2.....	66
$\overline{\text{CAS}}$ Latency = 3.....	67
Read And Write Cycle	
$\overline{\text{CAS}}$ Latency = 1	68
$\overline{\text{CAS}}$ Latency = 2.....	69
$\overline{\text{CAS}}$ Latency = 3.....	70

Timing Diagrams	Page
Interleaved Column Read Cycle	
$\overline{\text{CAS}}$ Latency = 1	71
$\overline{\text{CAS}}$ Latency = 2	72
$\overline{\text{CAS}}$ Latency = 3	73
Interleaved Column Write Cycle	
$\overline{\text{CAS}}$ Latency = 1	74
$\overline{\text{CAS}}$ Latency = 2	75
$\overline{\text{CAS}}$ Latency = 3	76
Auto Precharge after a Read Burst	
$\overline{\text{CAS}}$ Latency = 1	77
$\overline{\text{CAS}}$ Latency = 2	78
$\overline{\text{CAS}}$ Latency = 3	79
Auto Precharge after a Write Burst	
$\overline{\text{CAS}}$ Latency = 1	80
$\overline{\text{CAS}}$ Latency = 2	81
$\overline{\text{CAS}}$ Latency = 3	82
Full Page Read Cycle	
$\overline{\text{CAS}}$ Latency = 1	83
$\overline{\text{CAS}}$ Latency = 2	84
$\overline{\text{CAS}}$ Latency = 3	85
Full Page Write Cycle	
$\overline{\text{CAS}}$ Latency = 1	86
$\overline{\text{CAS}}$ Latency = 2	87
$\overline{\text{CAS}}$ Latency = 3	88
Byte Write Operation.....	89
Burst Read and Single Write Operation.....	90
Full Page Burst Read and Single Write Operation.....	91
Random Row Read (Interleaving Banks).....	92
Full Page Random Column Read	93
Full Page Random Column Write	94
Precharge Termination of a Burst	
$\overline{\text{CAS}}$ Latency = 1	95
$\overline{\text{CAS}}$ Latency = 2	96
$\overline{\text{CAS}}$ Latency = 3	97
$\overline{\text{CS}}$ Function (Only $\overline{\text{CS}}$ signal needs to be asserted at minimum rate).....	98

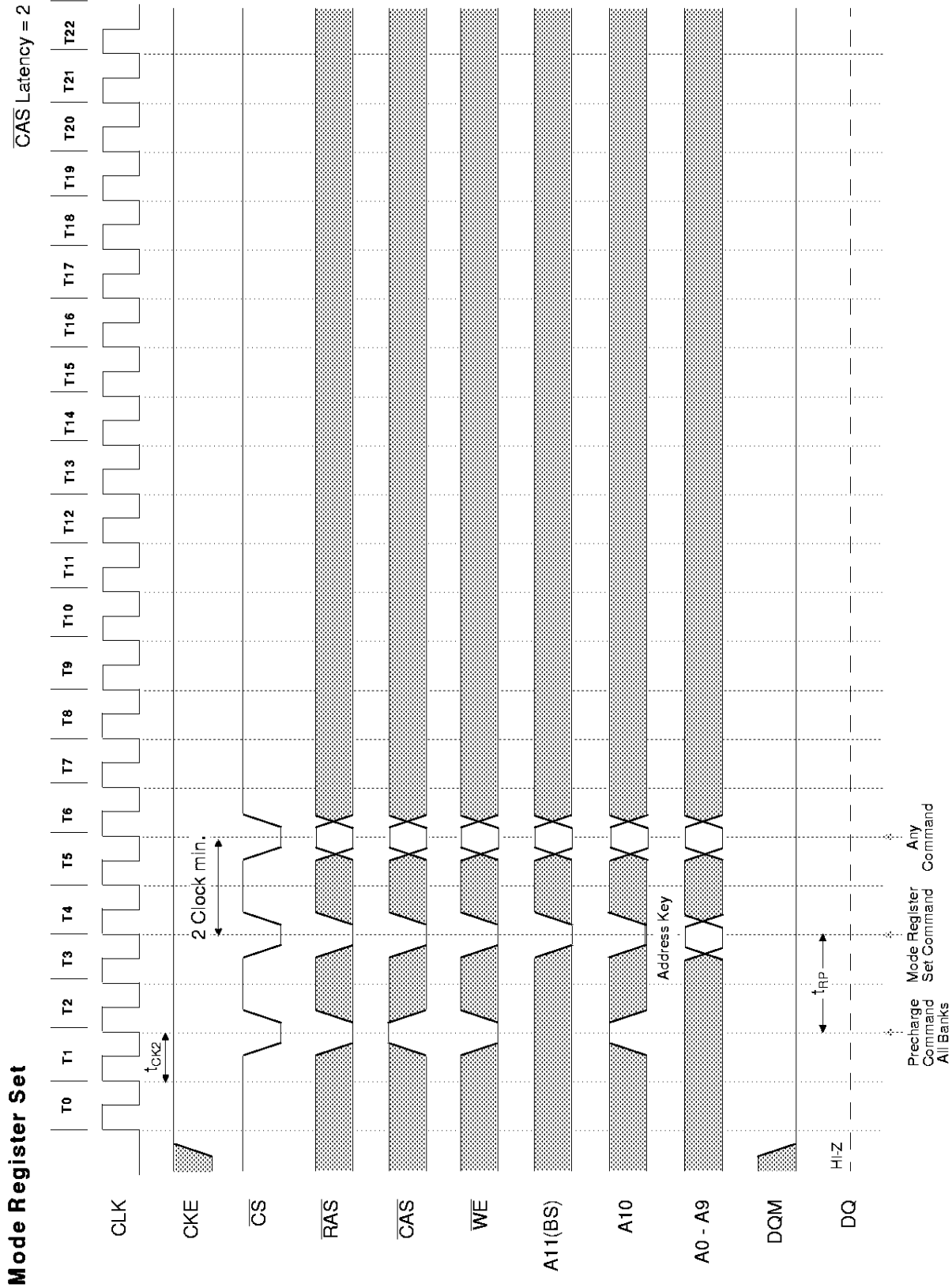



Power on Sequence and Auto Refresh (CBR)

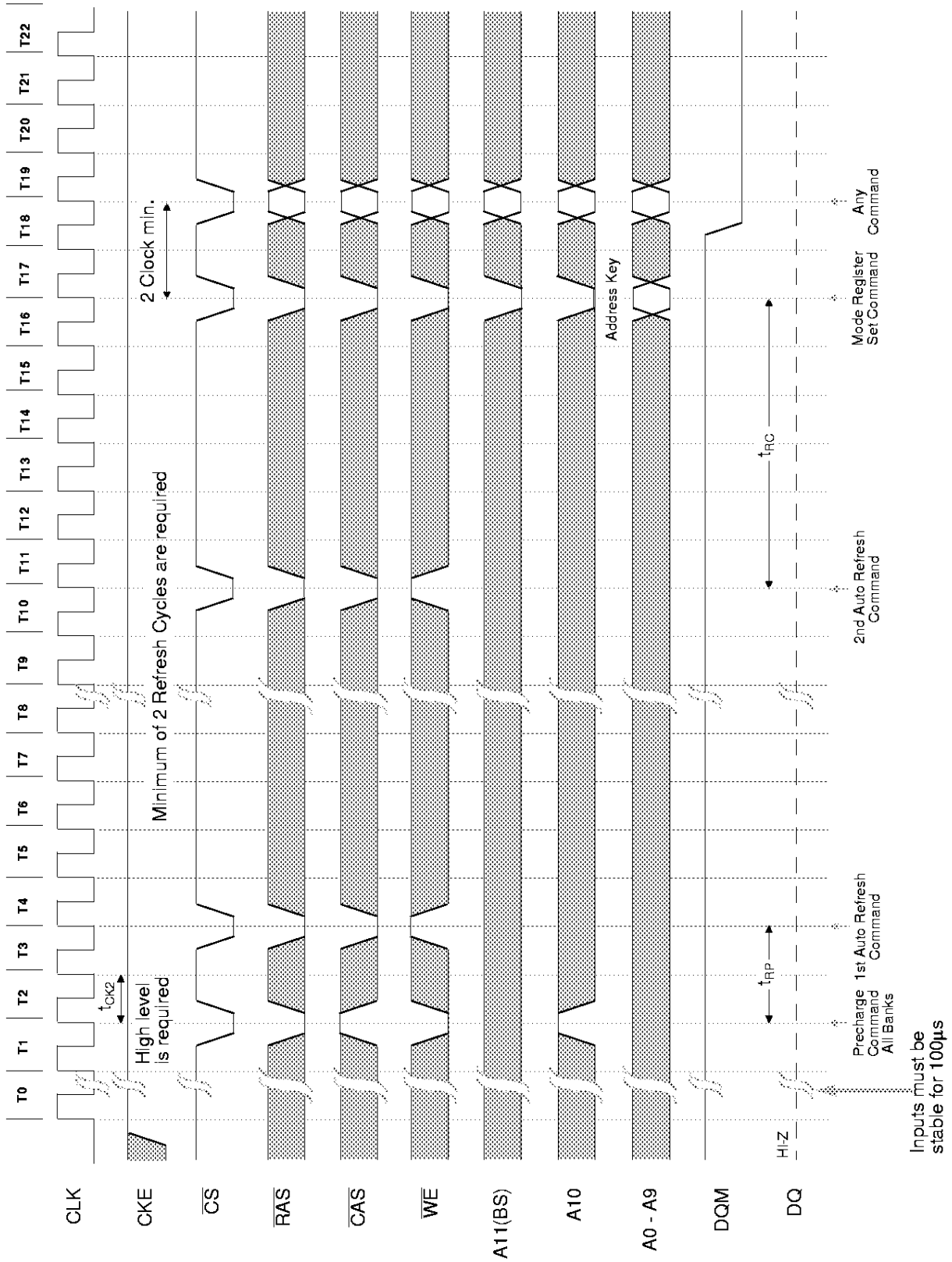



Clock Suspension During Burst Read (Using CKE) (1 of 3)

Burst Length = 4, CAS Latency = 1

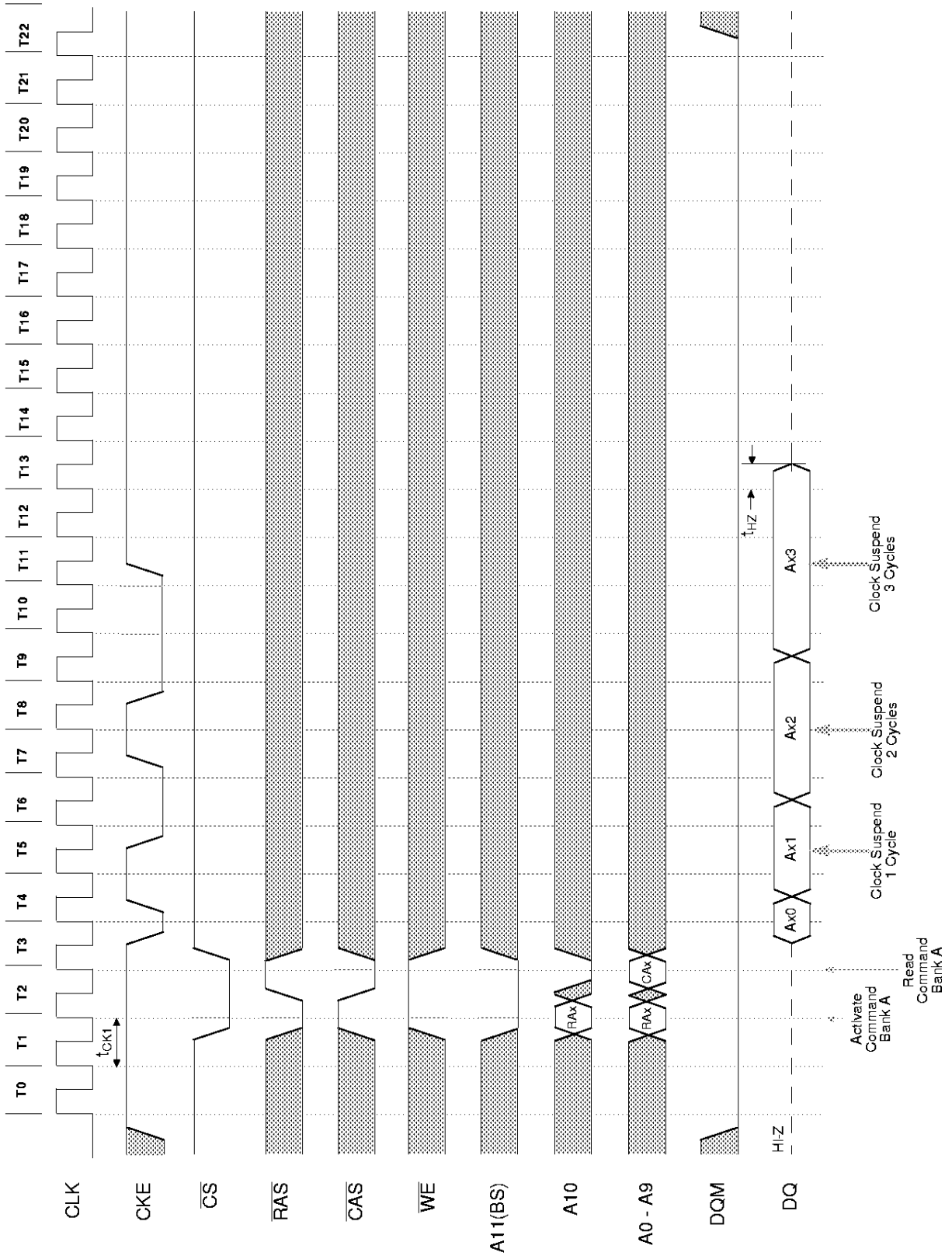



Clock Suspension During Burst Read (Using CKE) (2 of 3)

Burst Length = 4, CAS Latency = 2

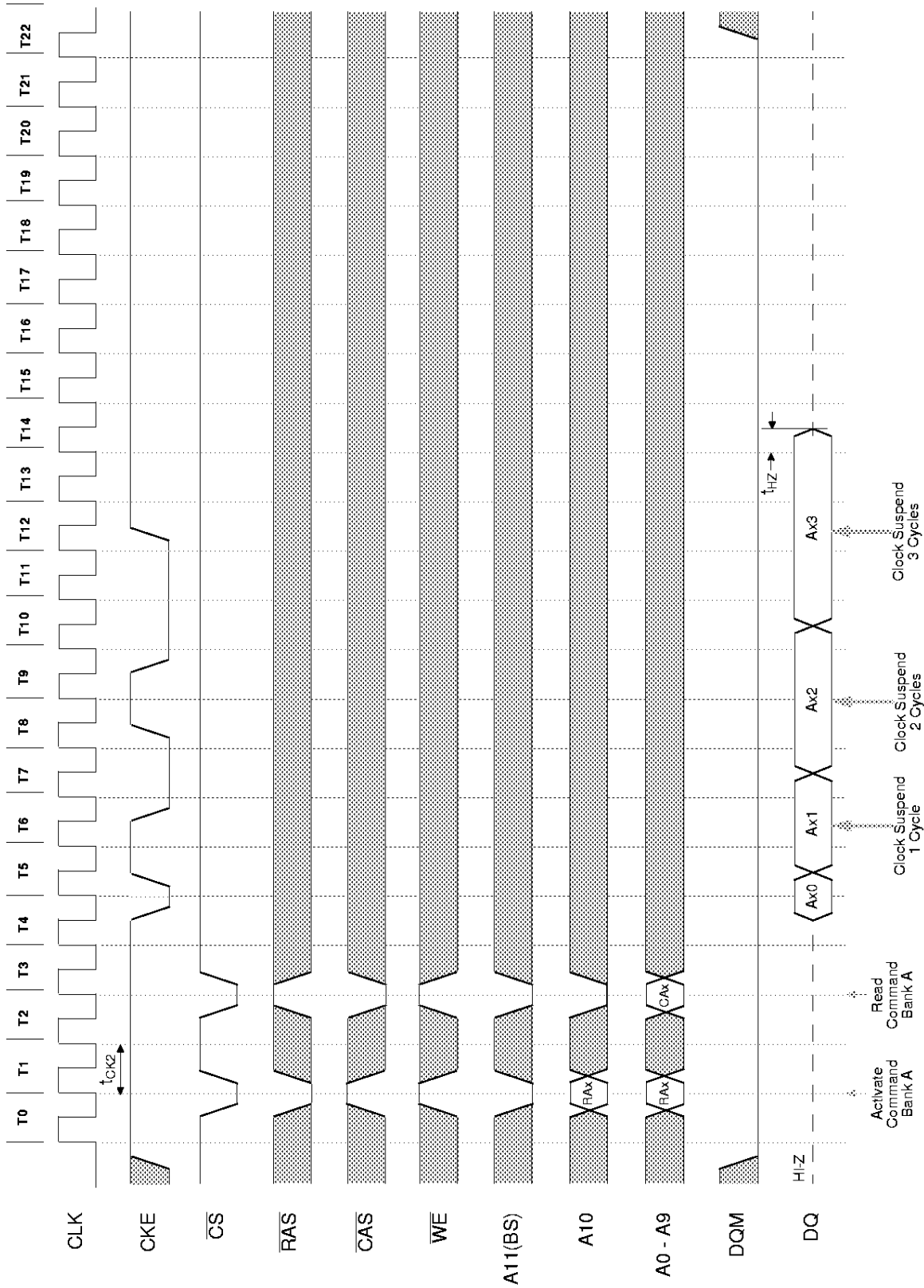



Clock Suspension During Burst Read (Using CKE) (3 of 3)

Burst Length = 4, CAS Latency = 3

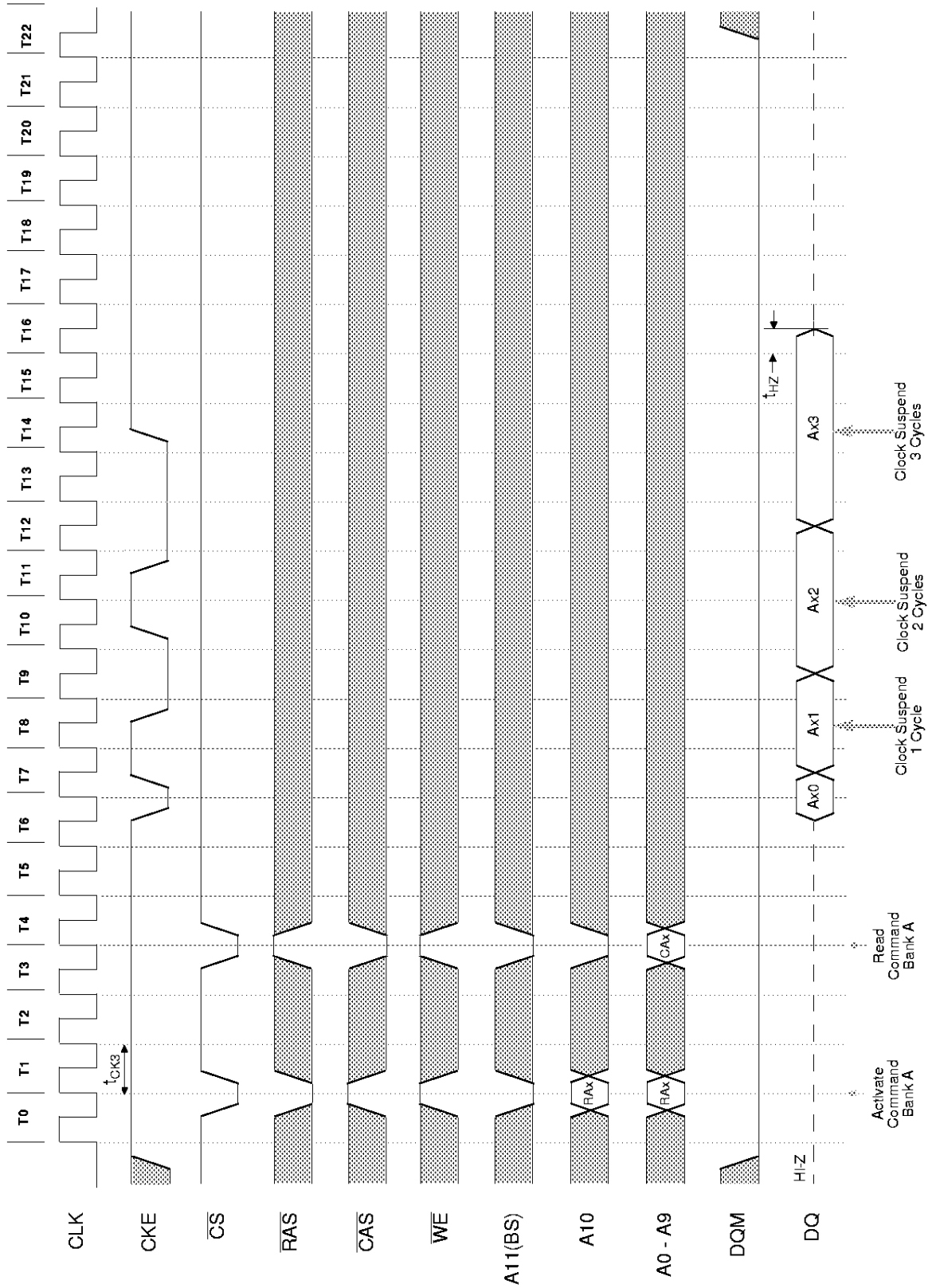



Clock Suspension During Burst Write (Using CKE) (1 of 3)

Burst Length = 4, CAS Latency = 1

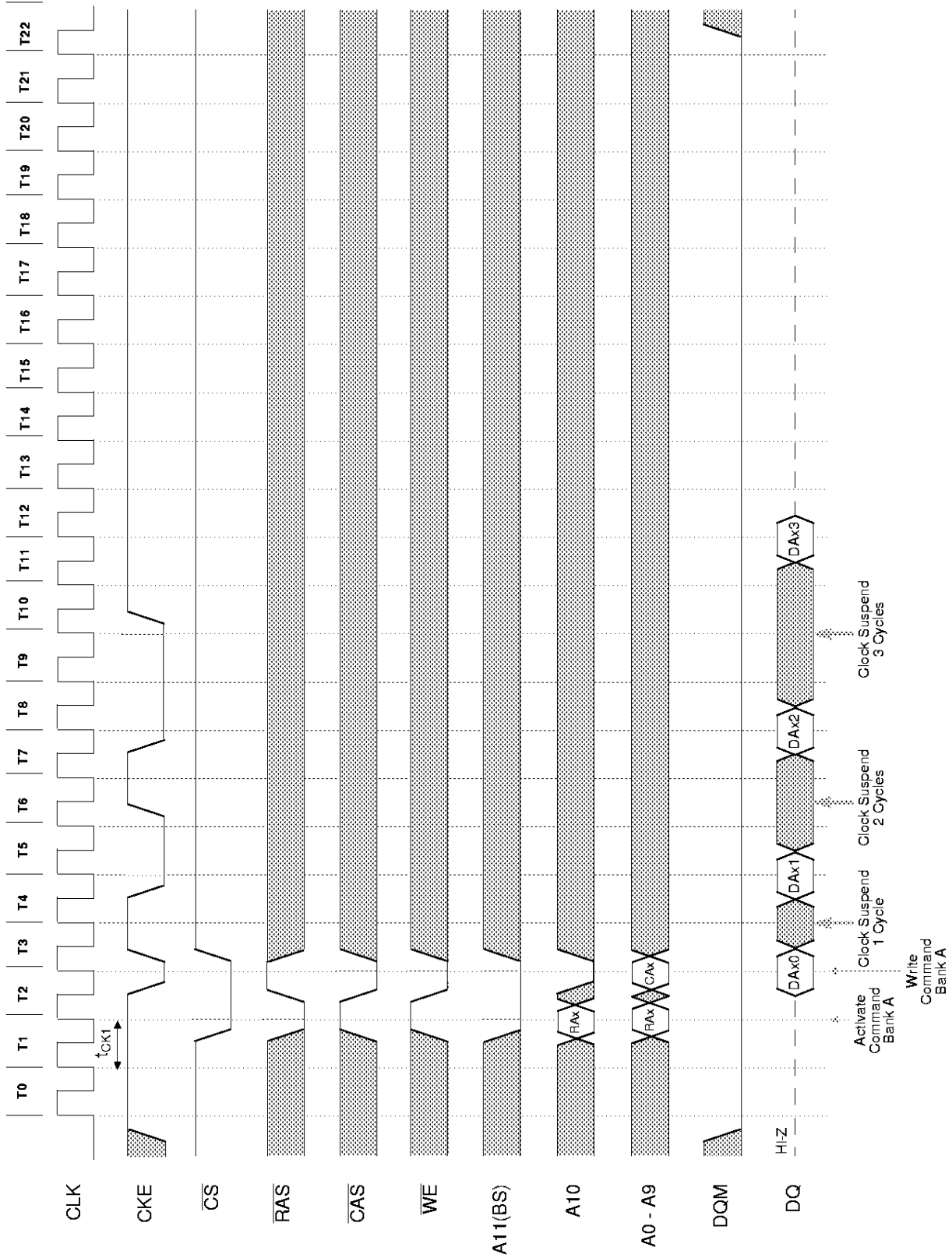



Clock Suspension During Burst Write (Using CKE) (2 of 3)

Burst Length = 4, CAS Latency = 2

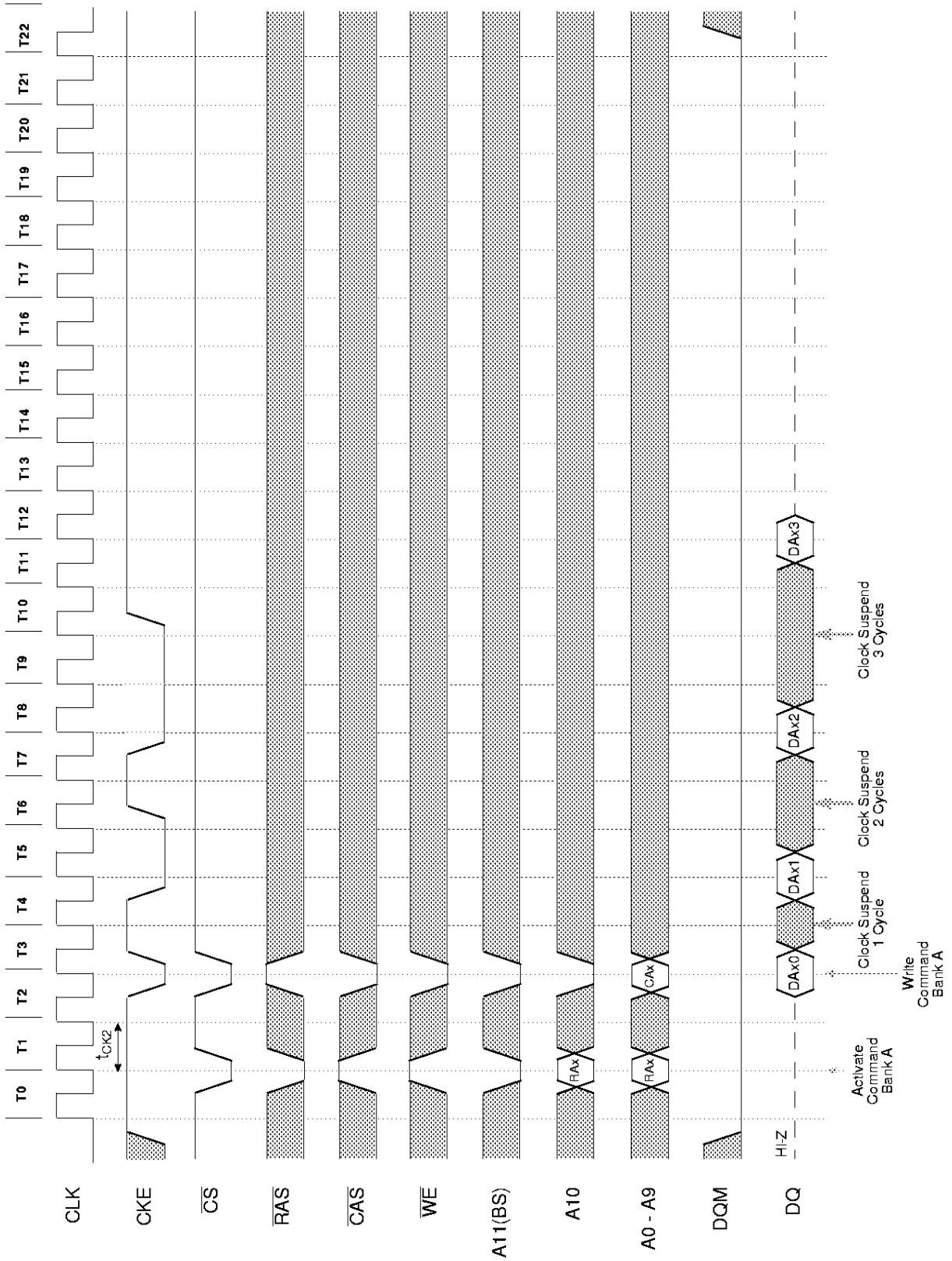



Clock Suspension During Burst Write (Using CKE) (3 of 3)

Burst Length = 4, CAS Latency = 3

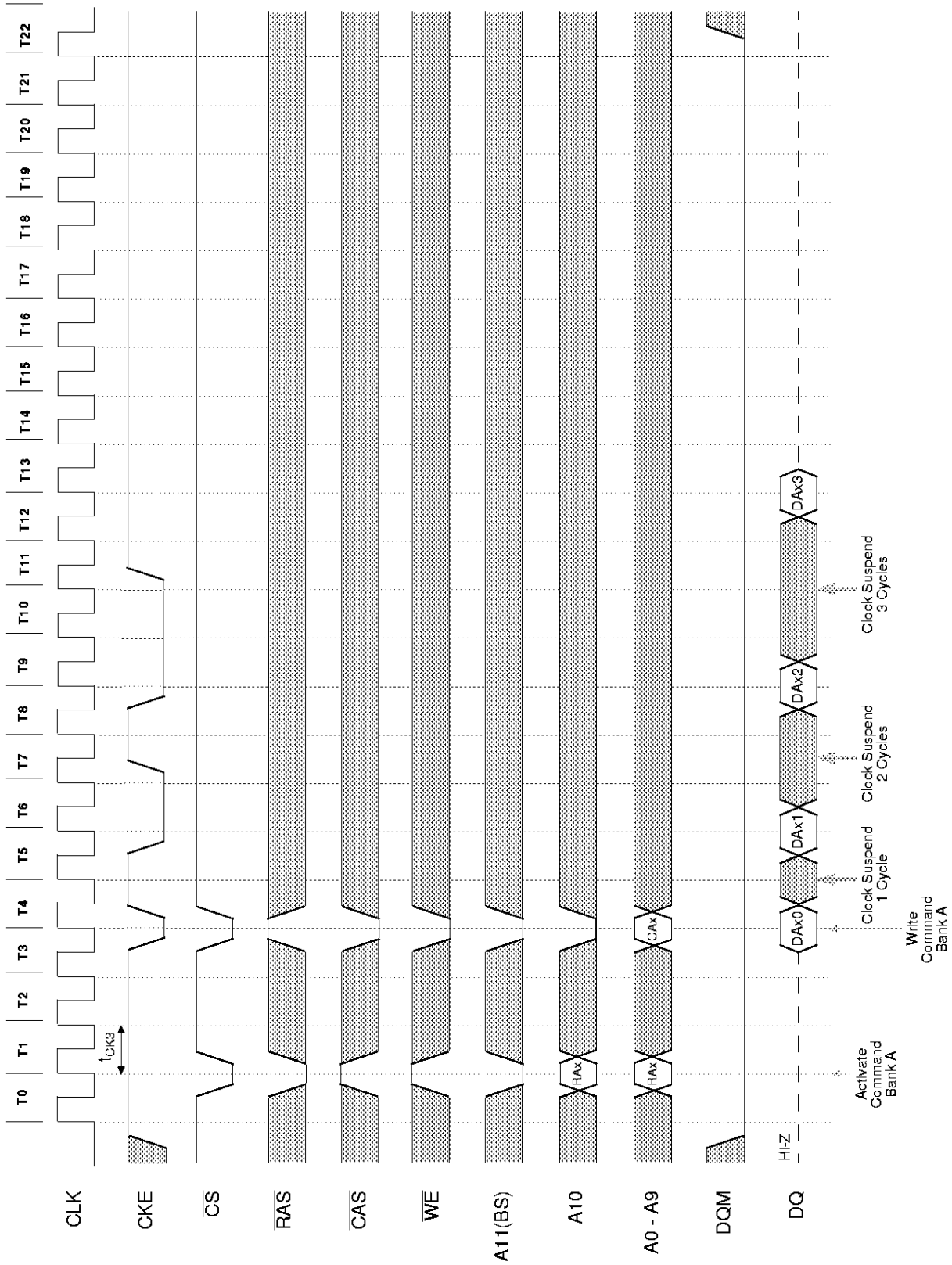



Power Down Mode and Clock Suspend

Burst Length = 4, CAS Latency = 2

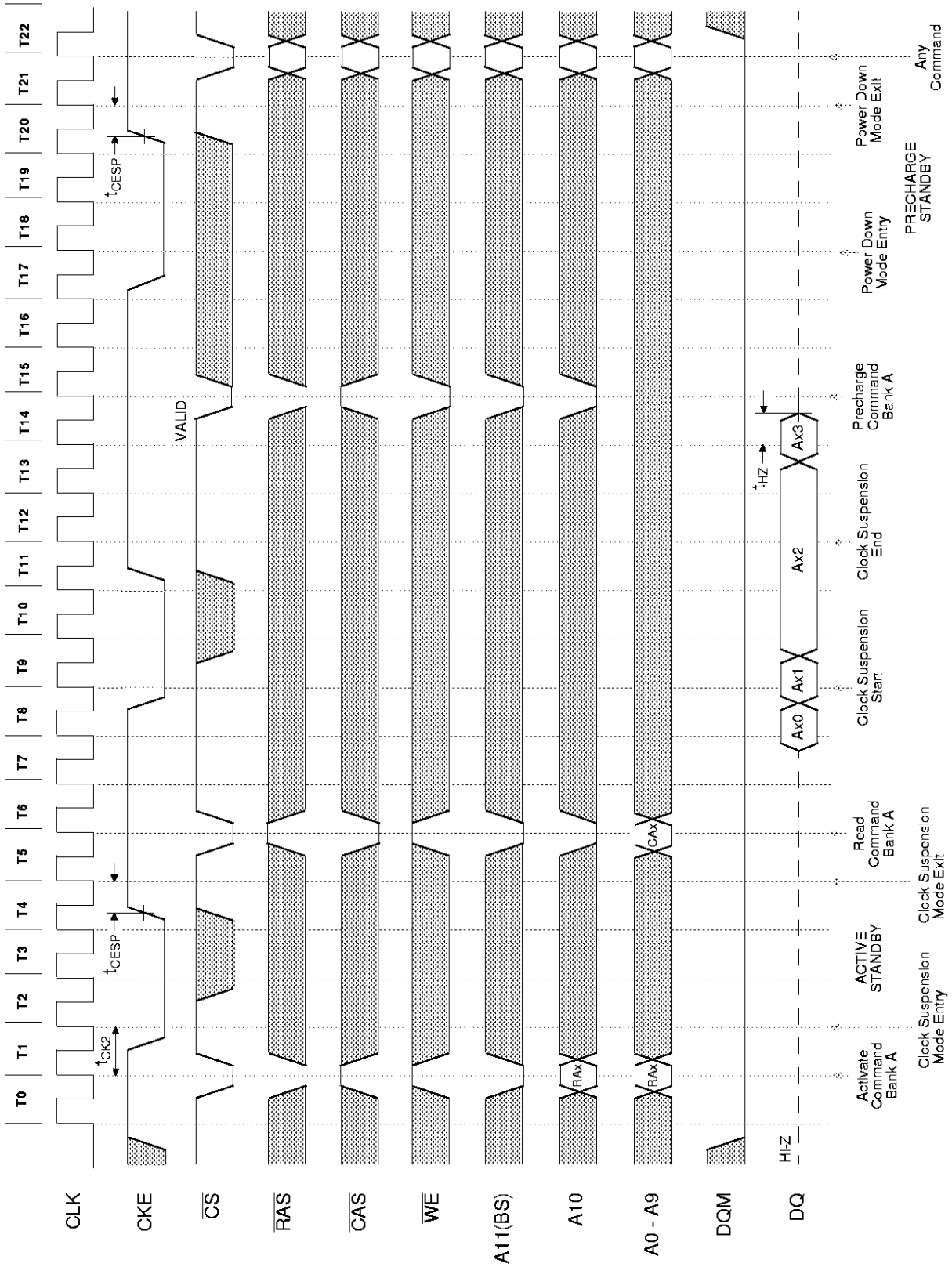



16Mb Synchronous DRAM

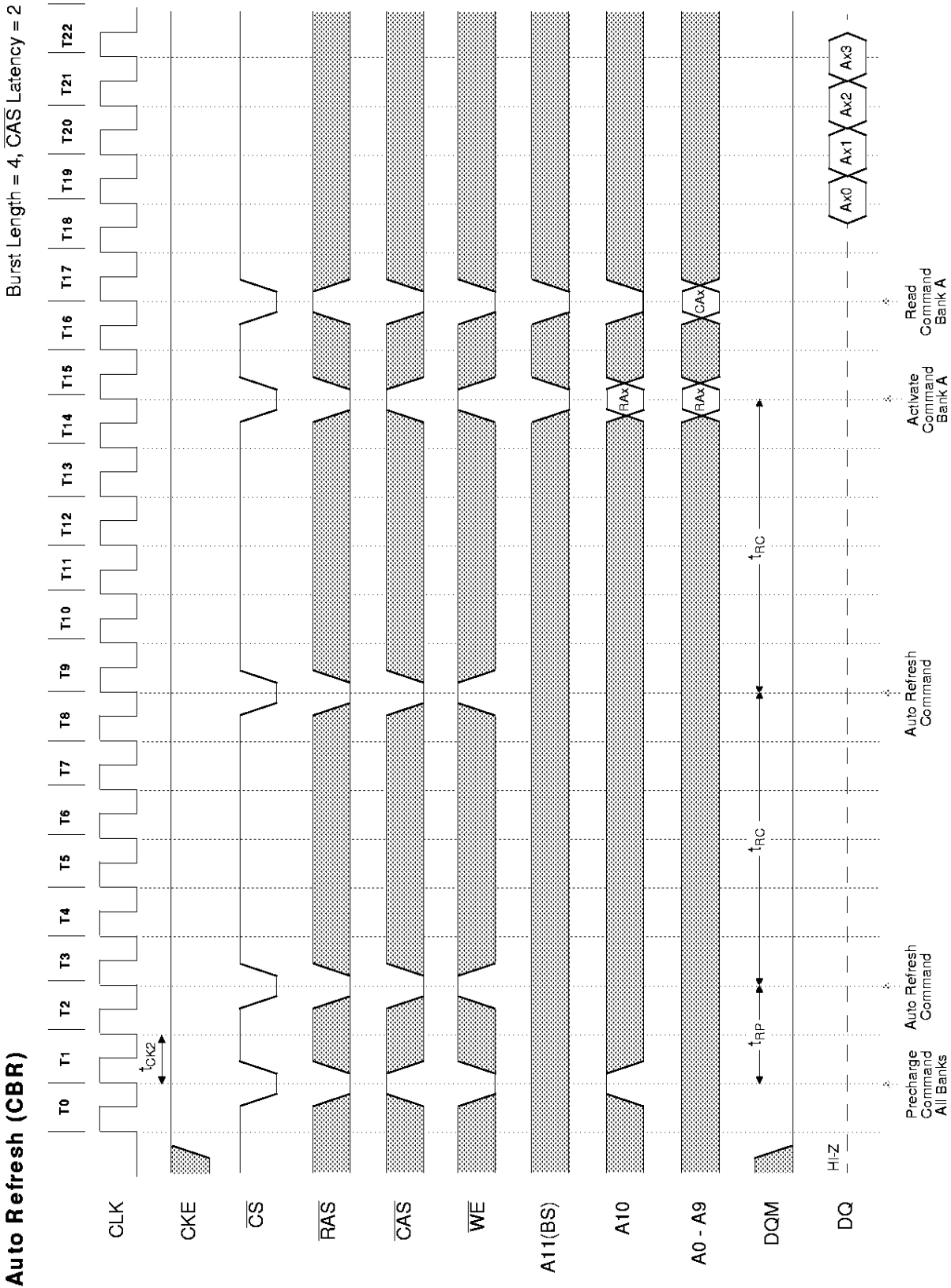



Random Column Read (Page within same Bank) (1 of 3)

Burst Length = 4, CAS Latency = 1

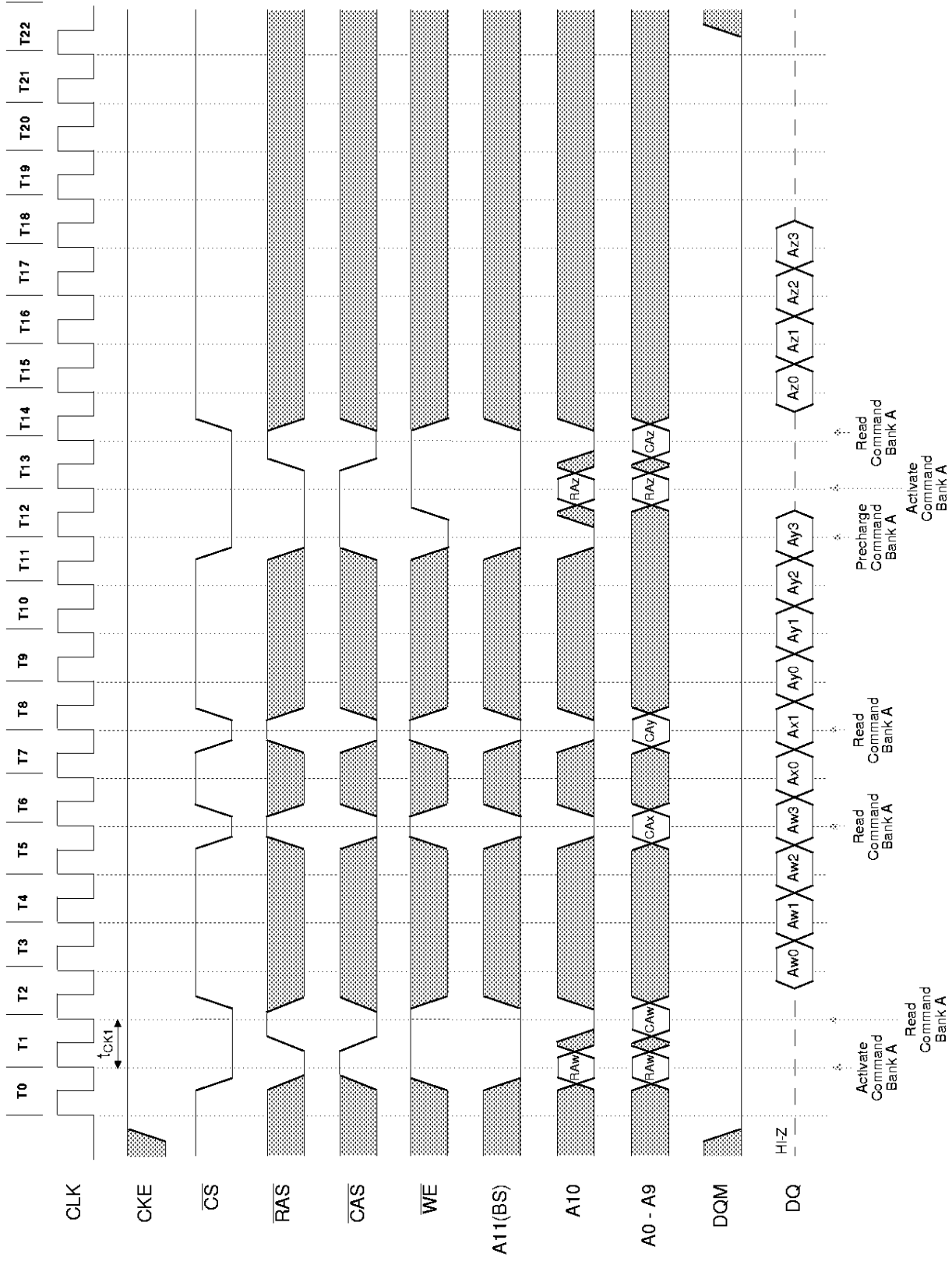



Random Column Read (Page within same Bank) (2 of 3)

Burst Length = 4, CAS Latency = 2

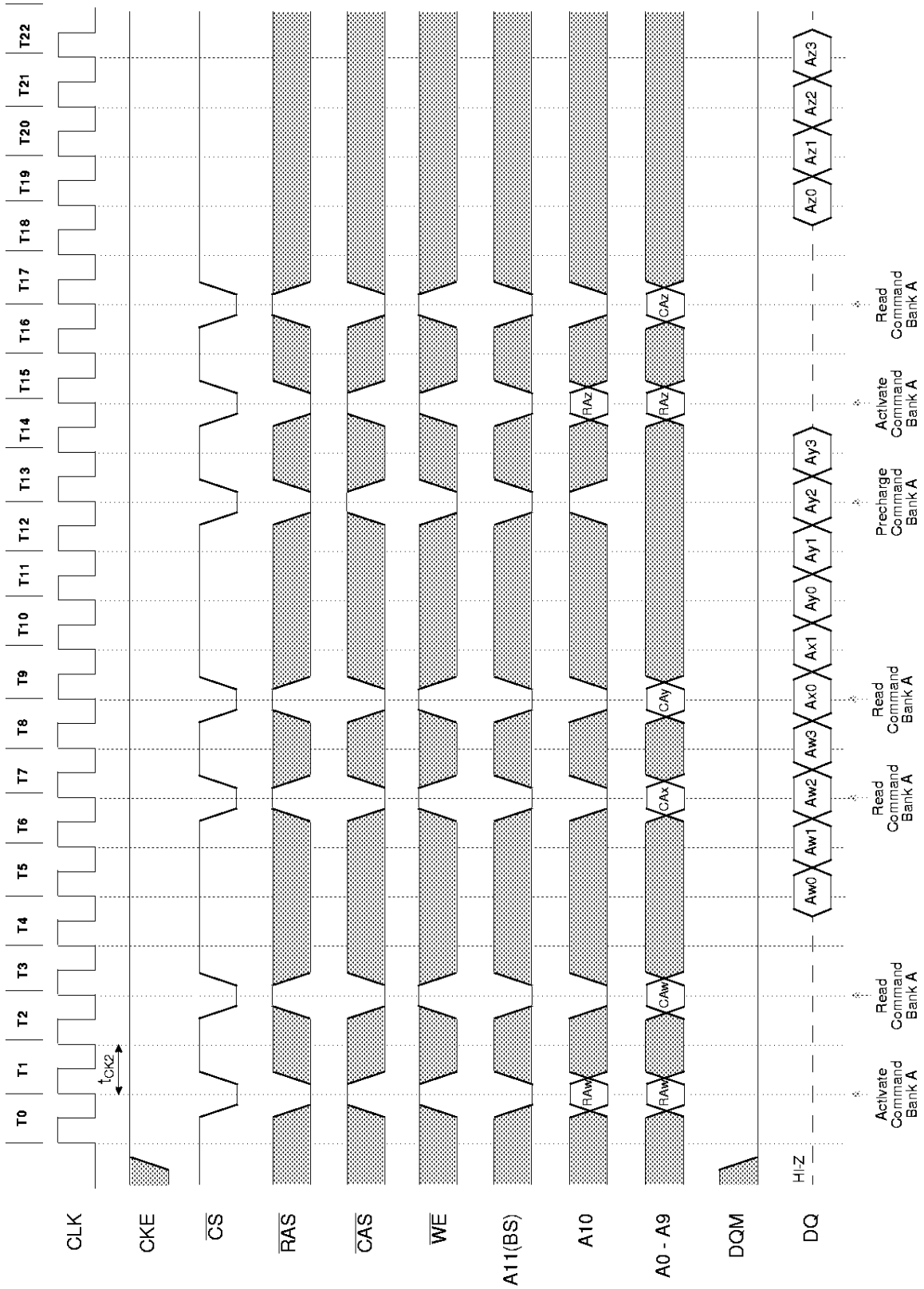



Random Column Read (Page within same Bank) (3 of 3)

Burst Length = 4, CAS Latency = 3

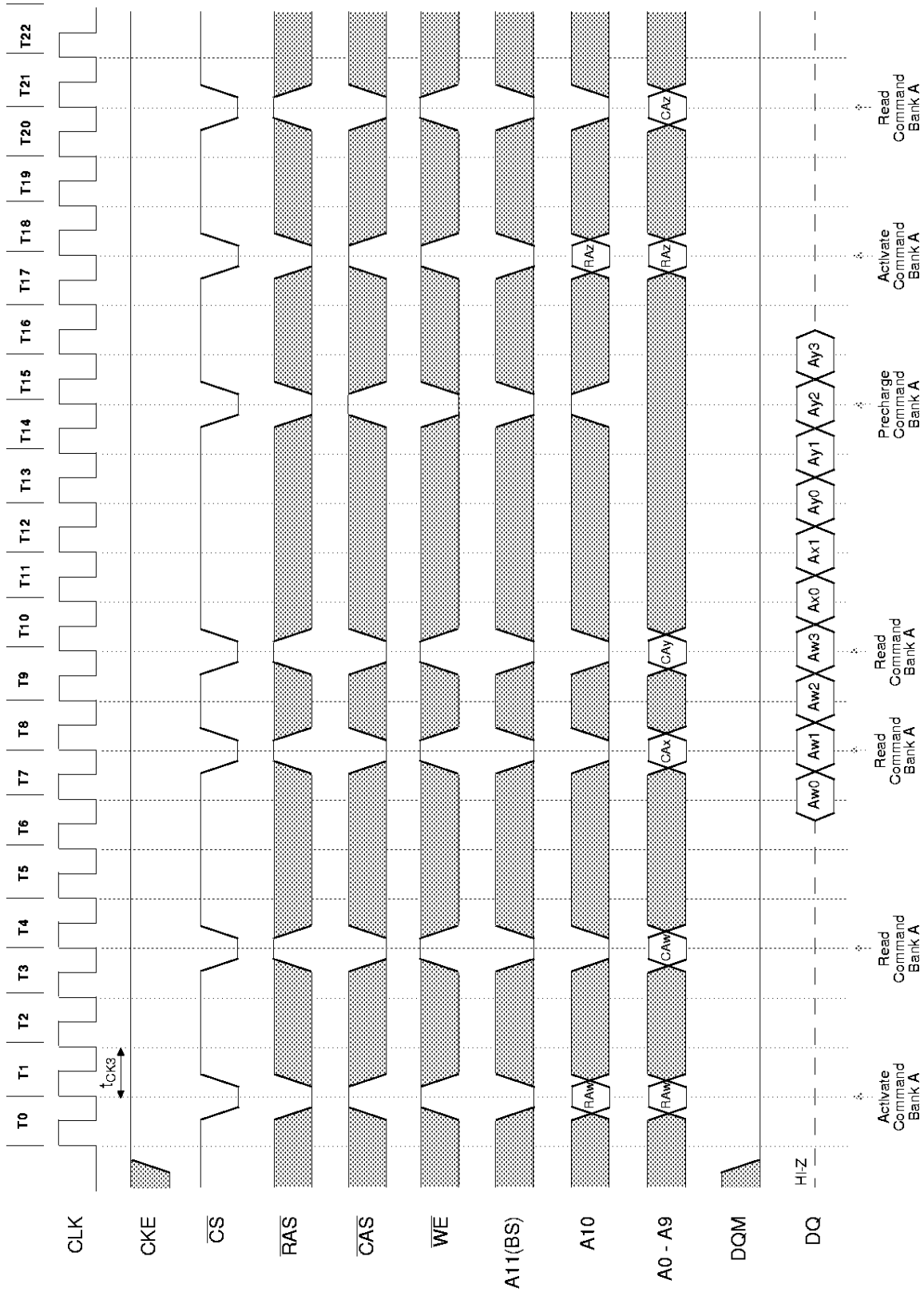



Random Column Write (Page within same Bank) (1 of 3)

Burst Length = 4, CAS Latency = 1

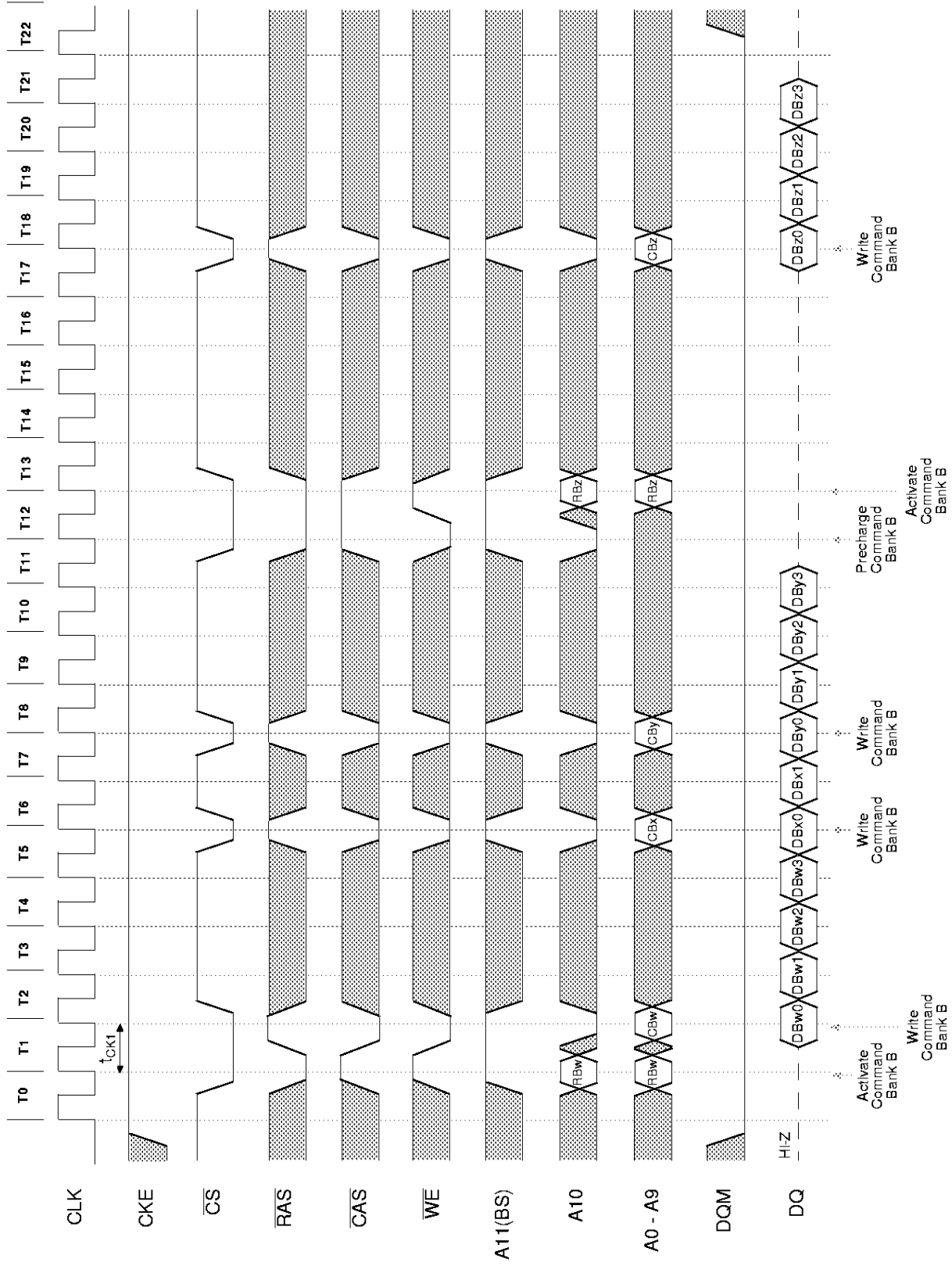



16Mb Synchronous DRAM

Burst Length = 4, CAS Latency = 2

Random Column Write (Page within same Bank) (2 of 3)

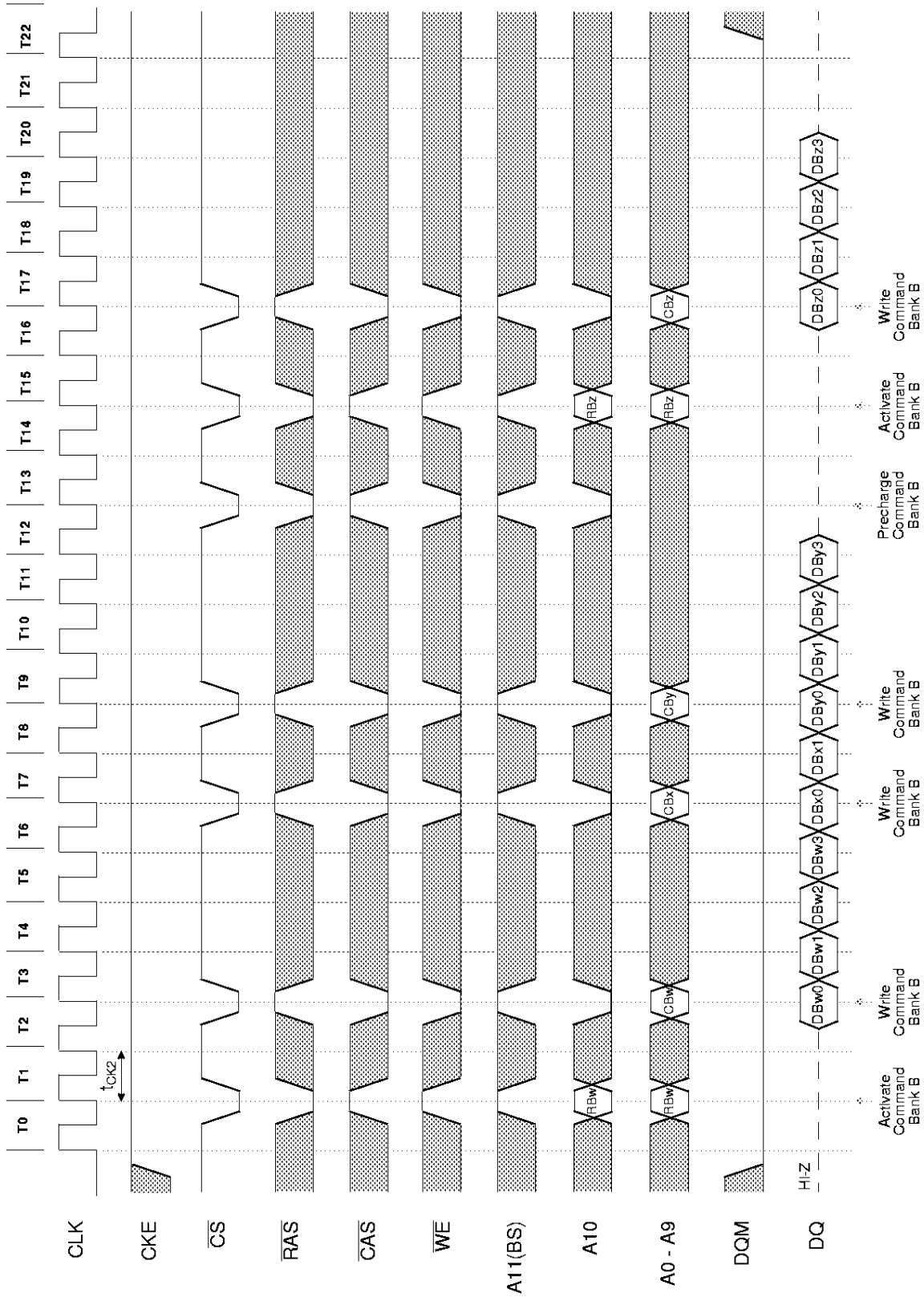

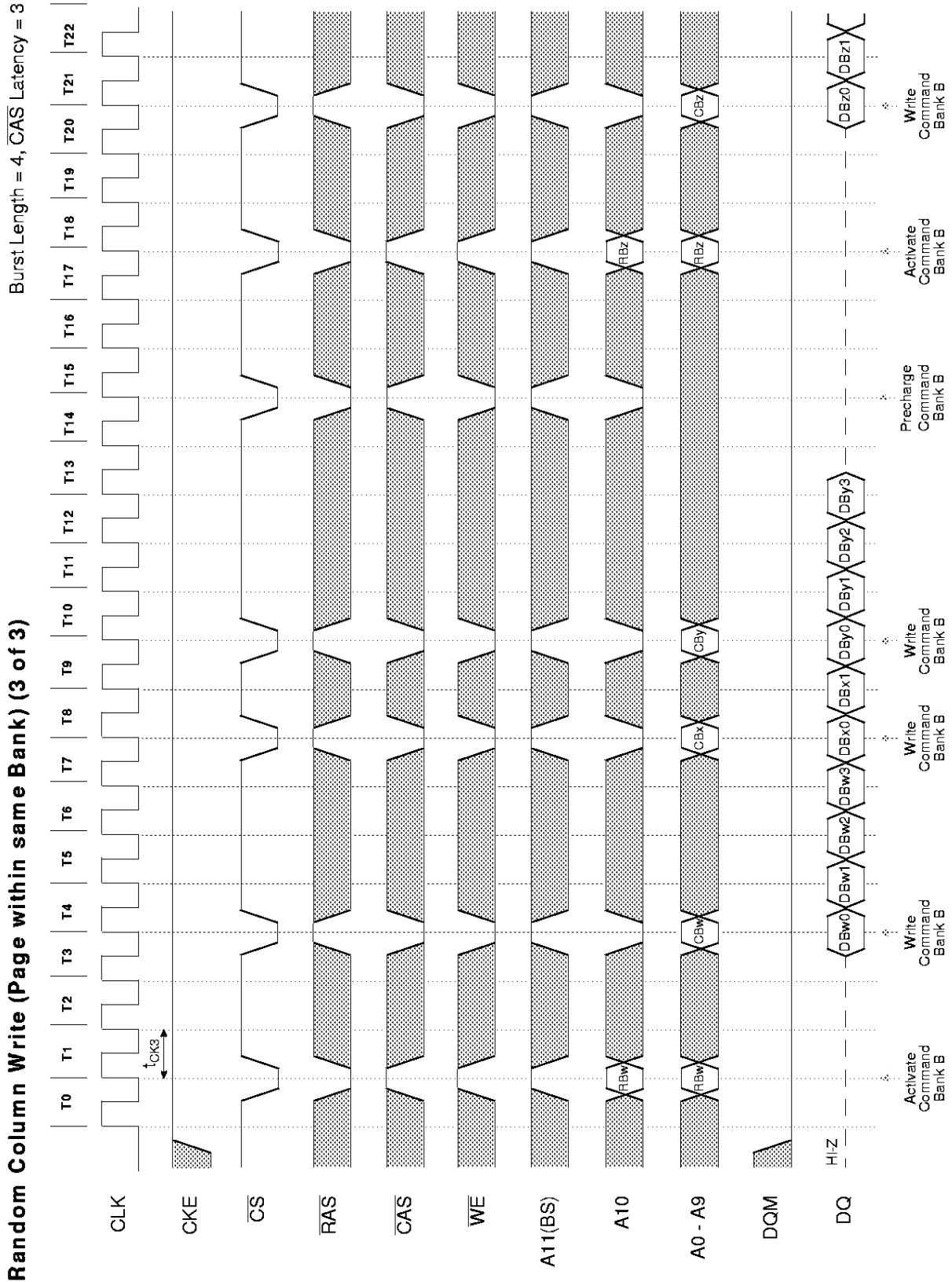



16Mb Synchronous DRAM

Random Row Read (Interleaving Banks) (1 of 3)

Burst Length = 8, CAS Latency = 1

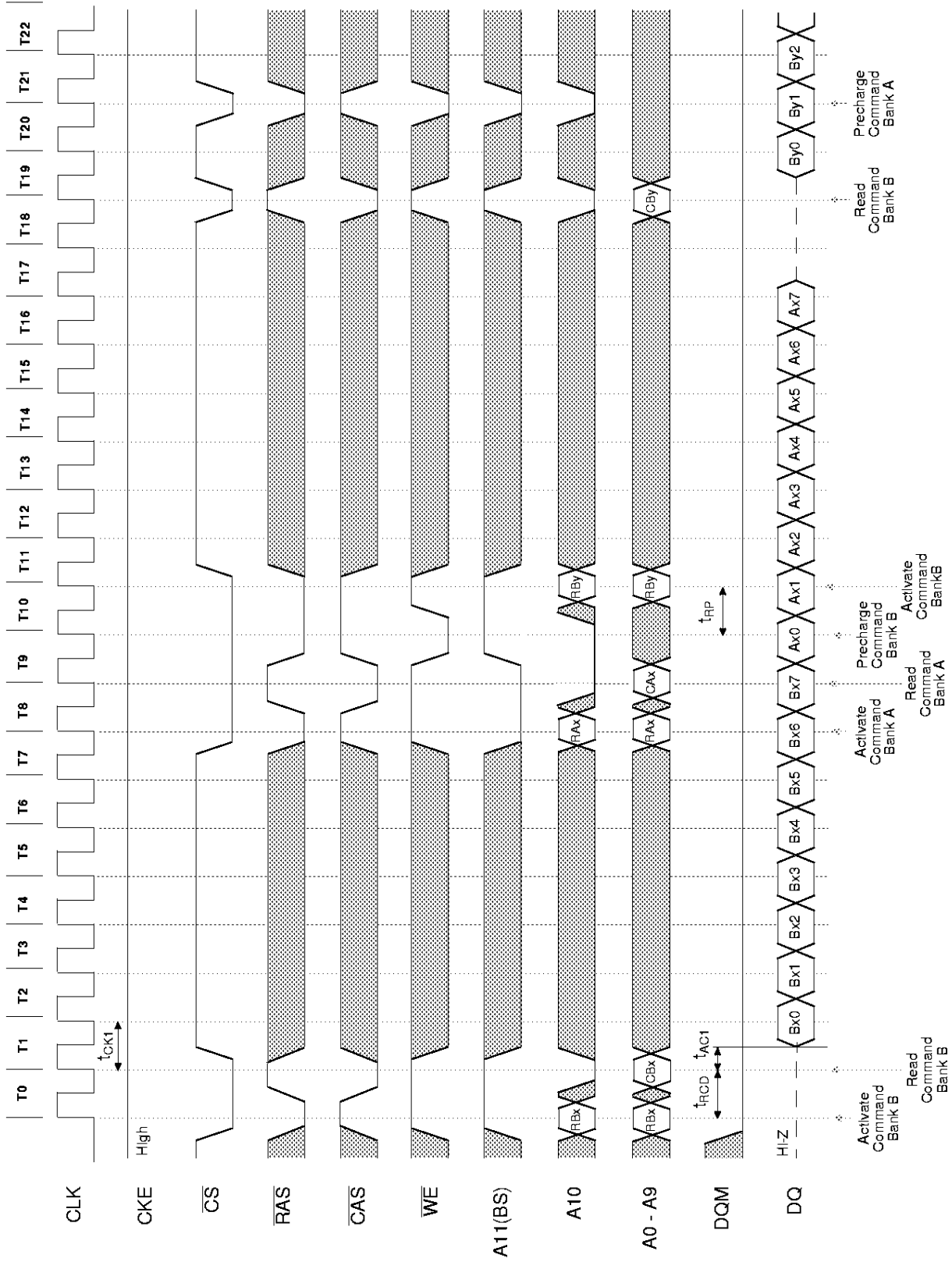



Random Row Read (Interleaving Banks) (2 of 3)

Burst Length = 8, CAS Latency = 2

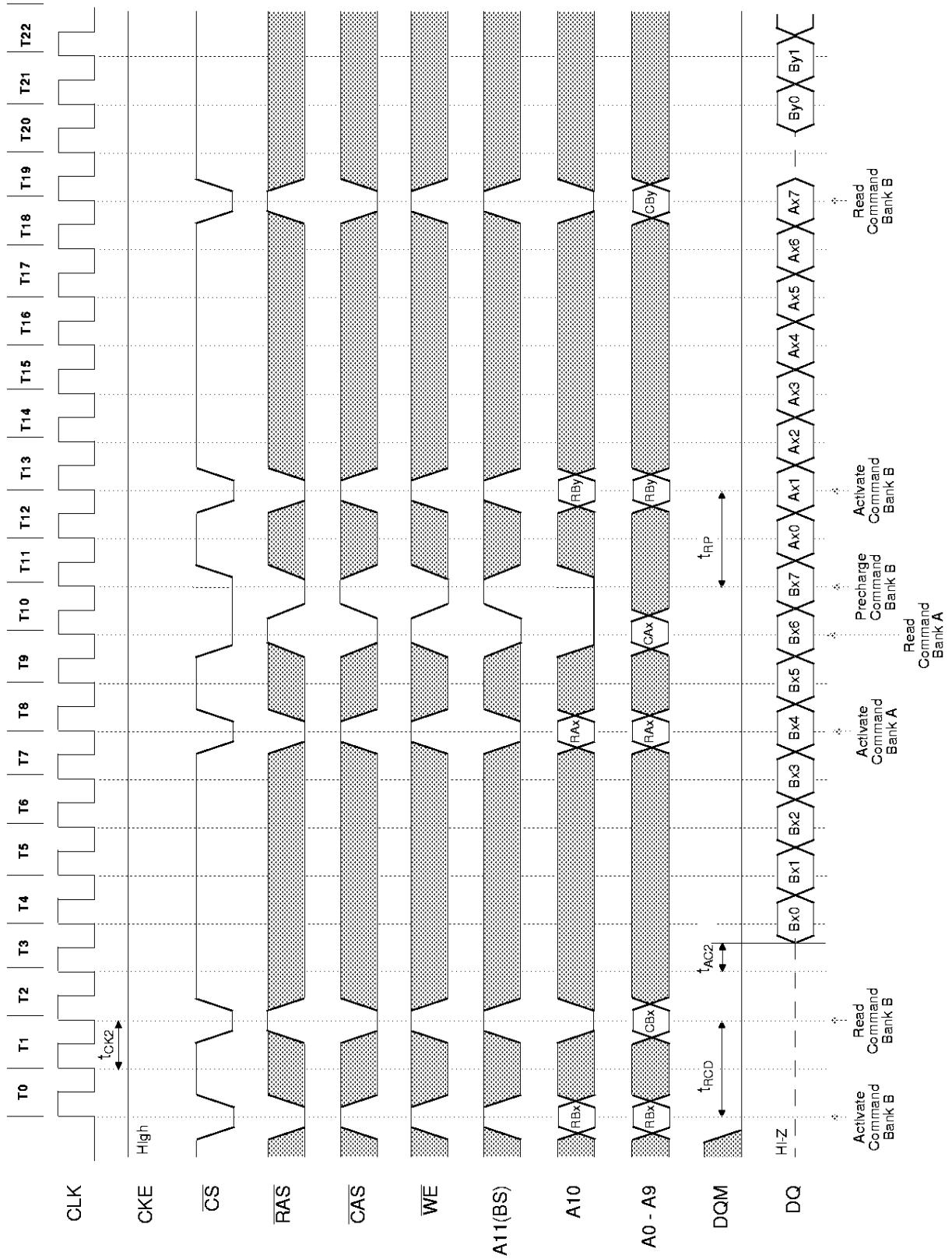



16Mb Synchronous DRAM

Random Row Read (Interleaving Banks) (3 of 3)

Burst Length = 8, CAS Latency = 3

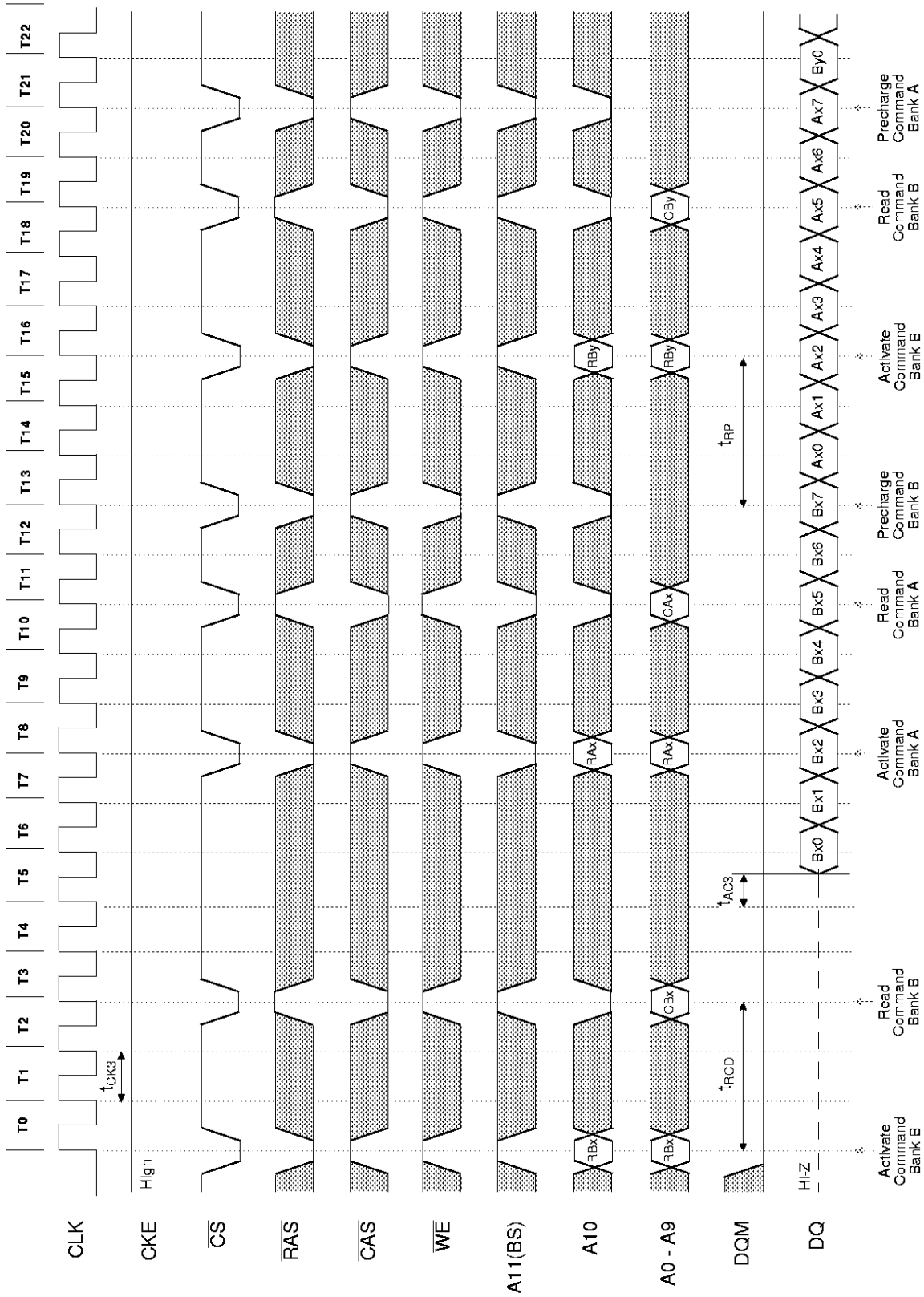



Random Row Write (Interleaving Banks) (1 of 3)

Burst Length = 8, CAS Latency = 1

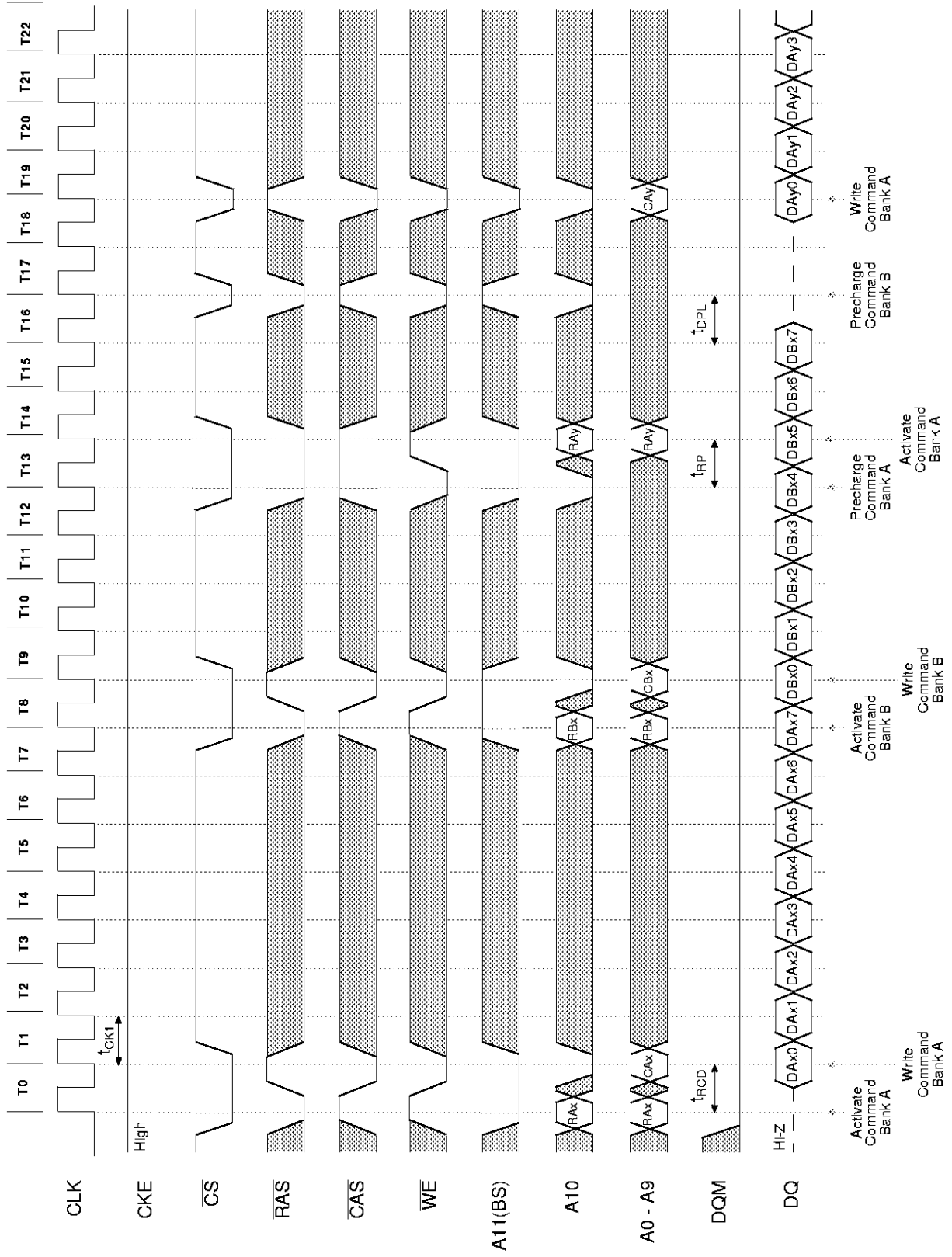



16Mb Synchronous DRAM

Random Row Write (Interleaving Banks) (2 of 3)

Burst Length = 8, CAS Latency = 2

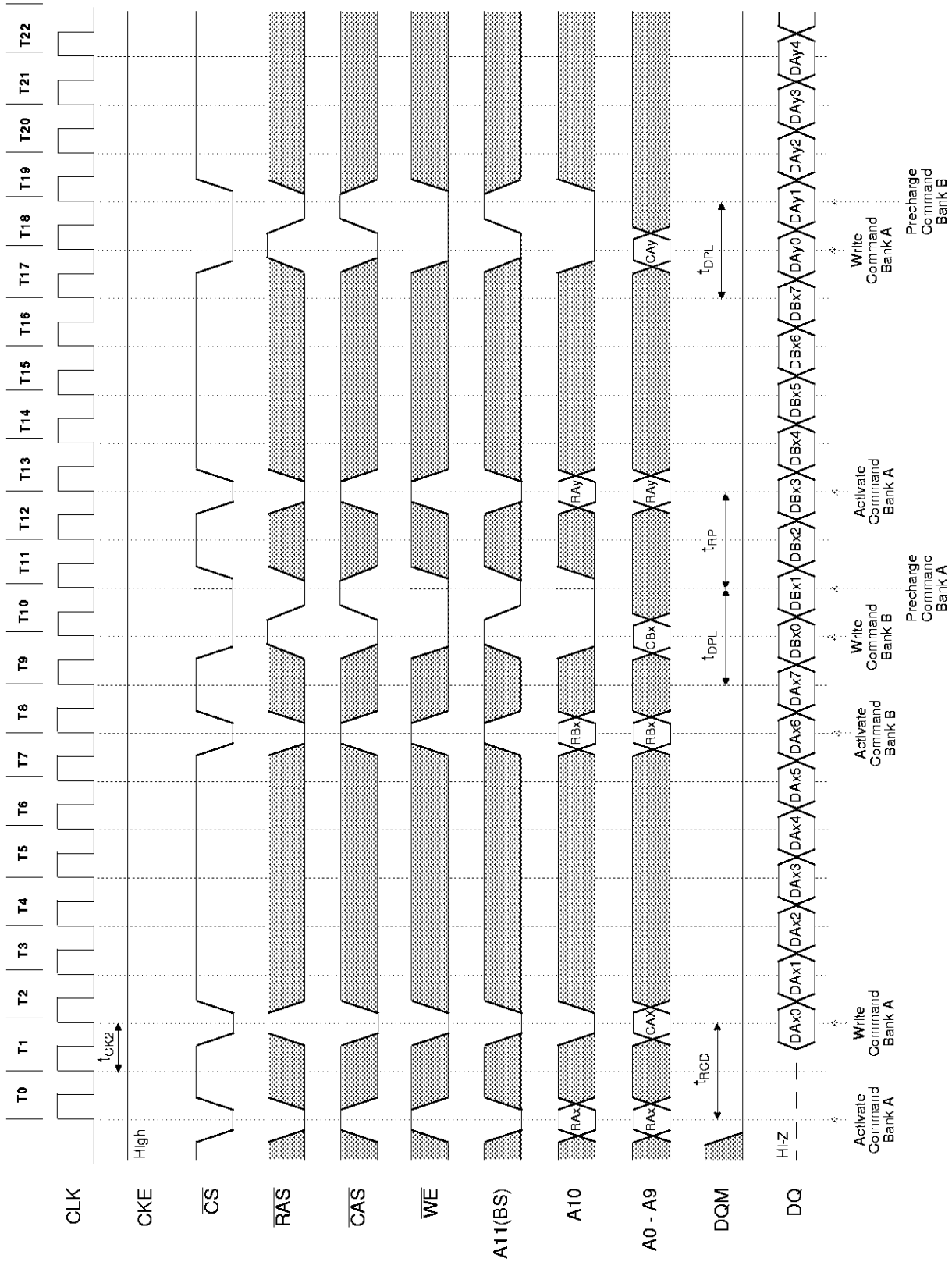



Random Row Write (Interleaving Banks) (3 of 3)

Burst Length = 8, CAS Latency = 3

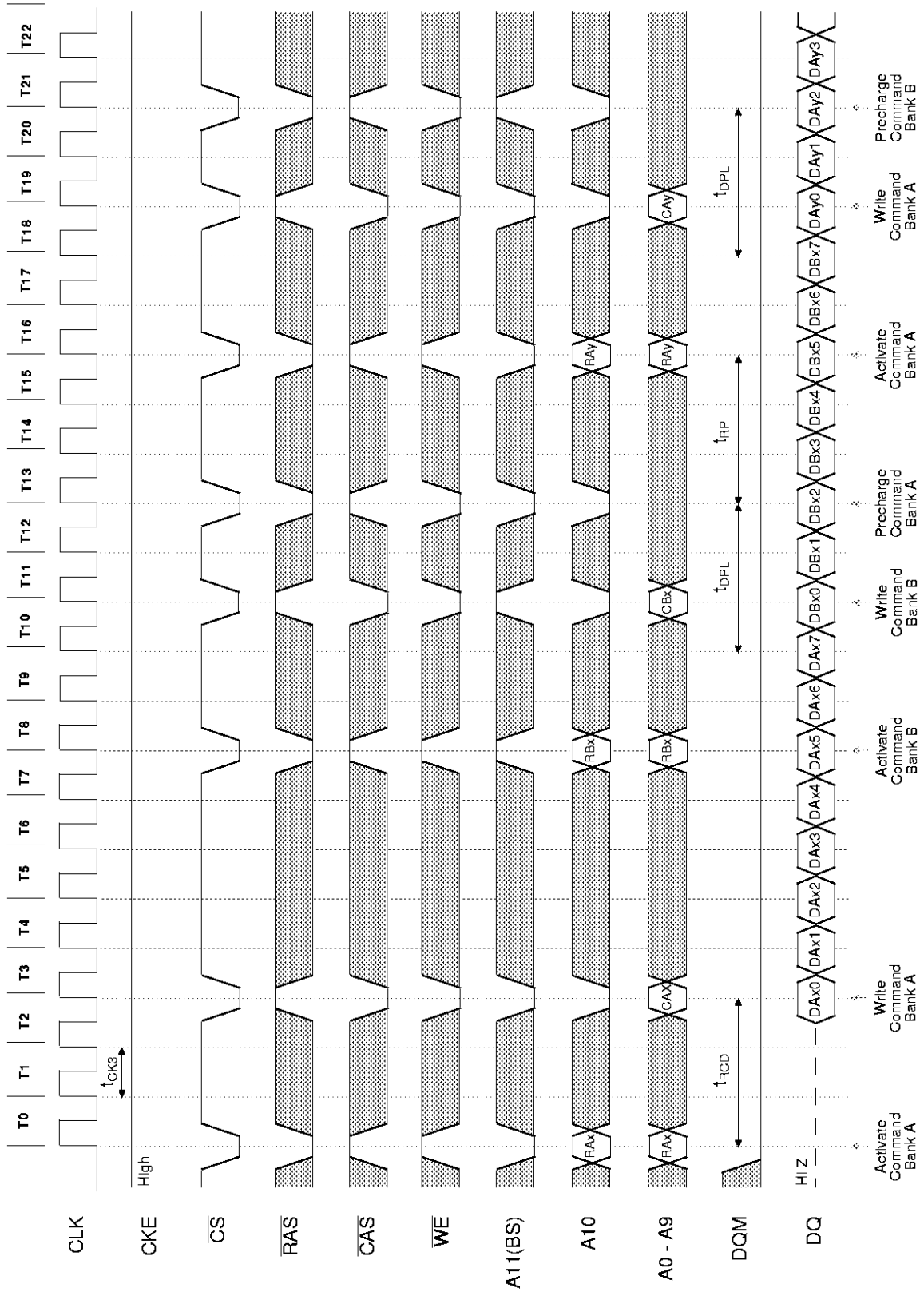



16Mb Synchronous DRAM

Read and Write Cycle (1 of 3)

Burst Length = 4, CAS Latency = 1

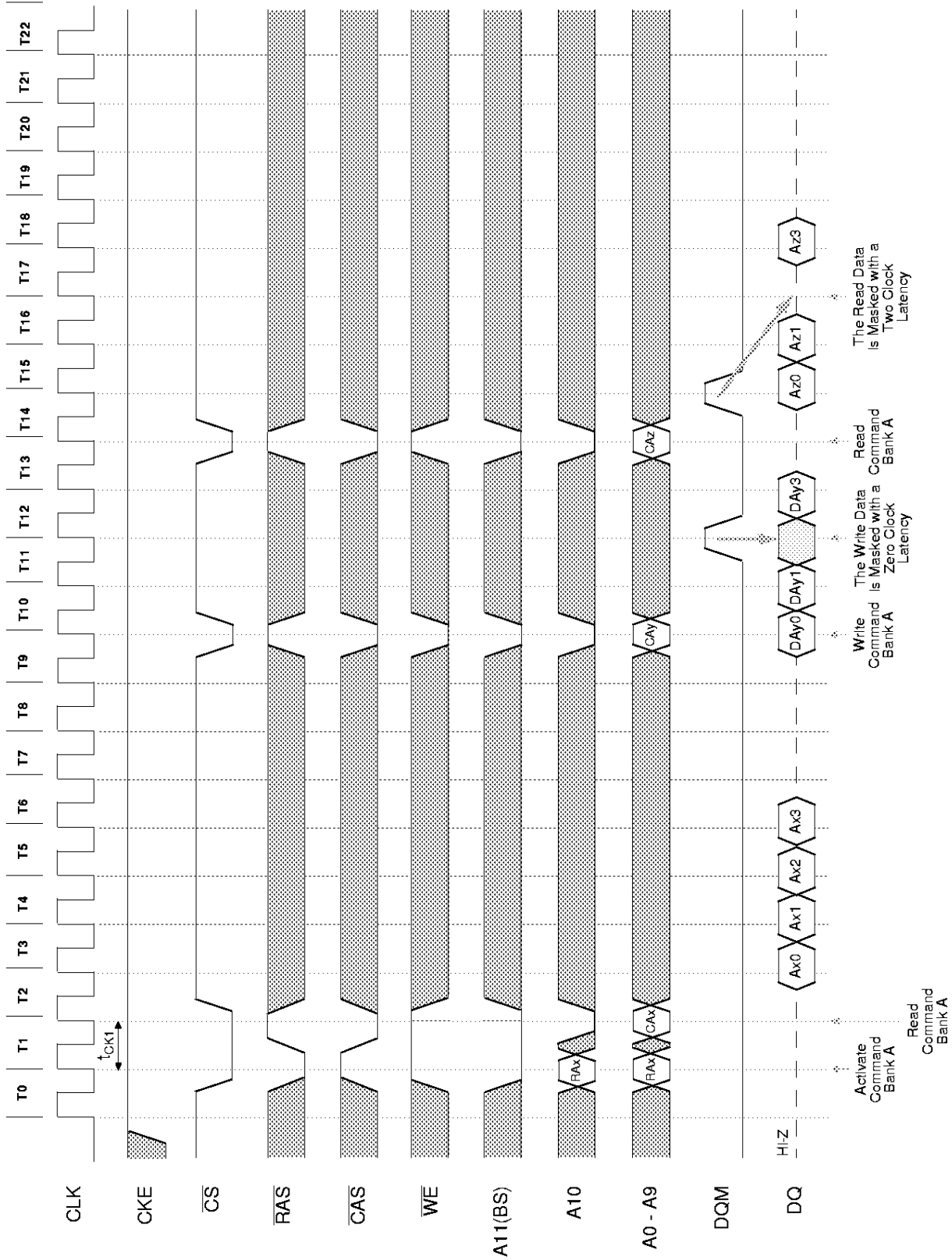



Read and Write Cycle (2 of 3)

Burst Length = 4, CAS Latency = 2

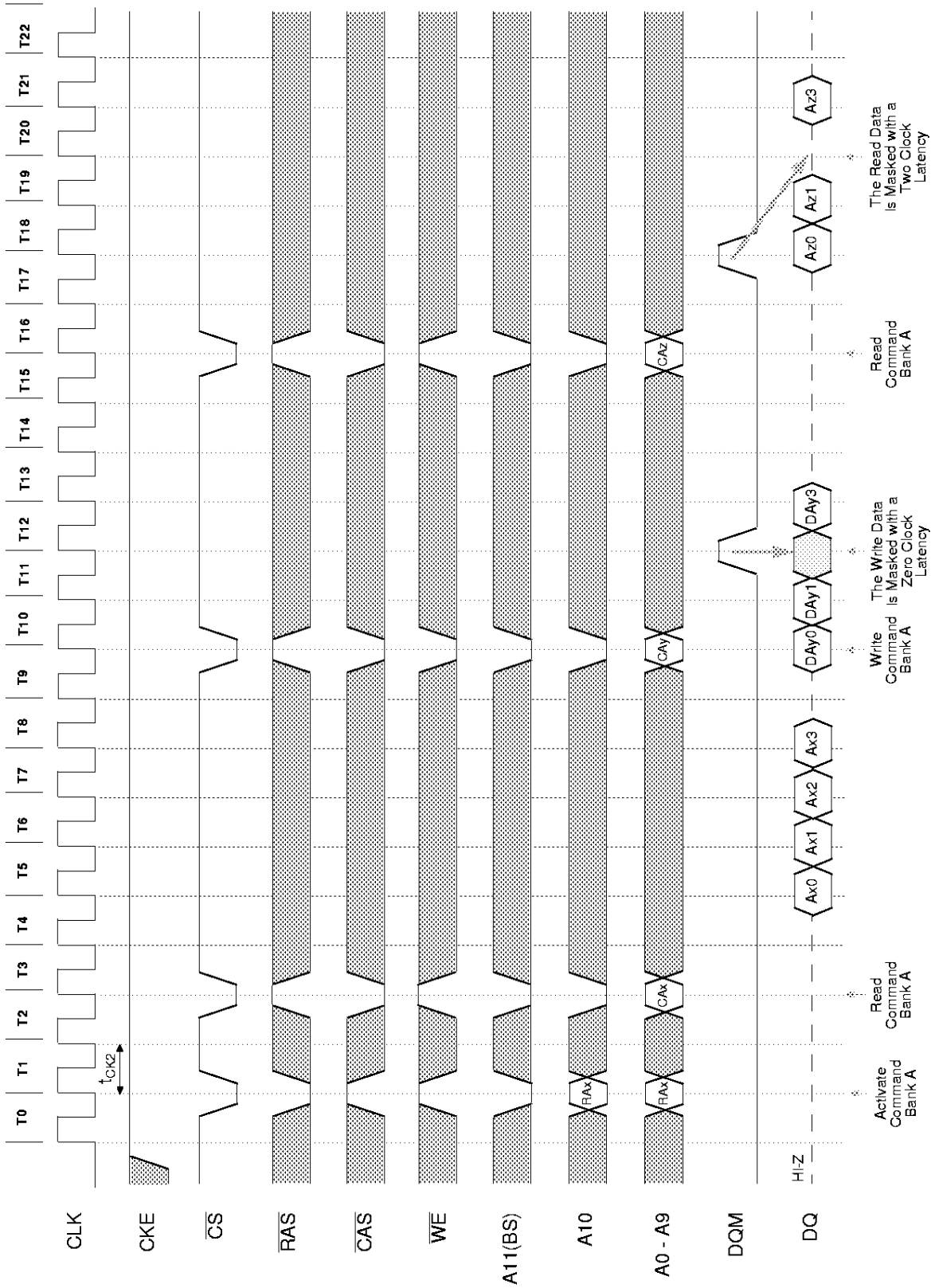



Read and Write Cycle (3 of 3)

Burst Length = 4, CAS Latency = 3

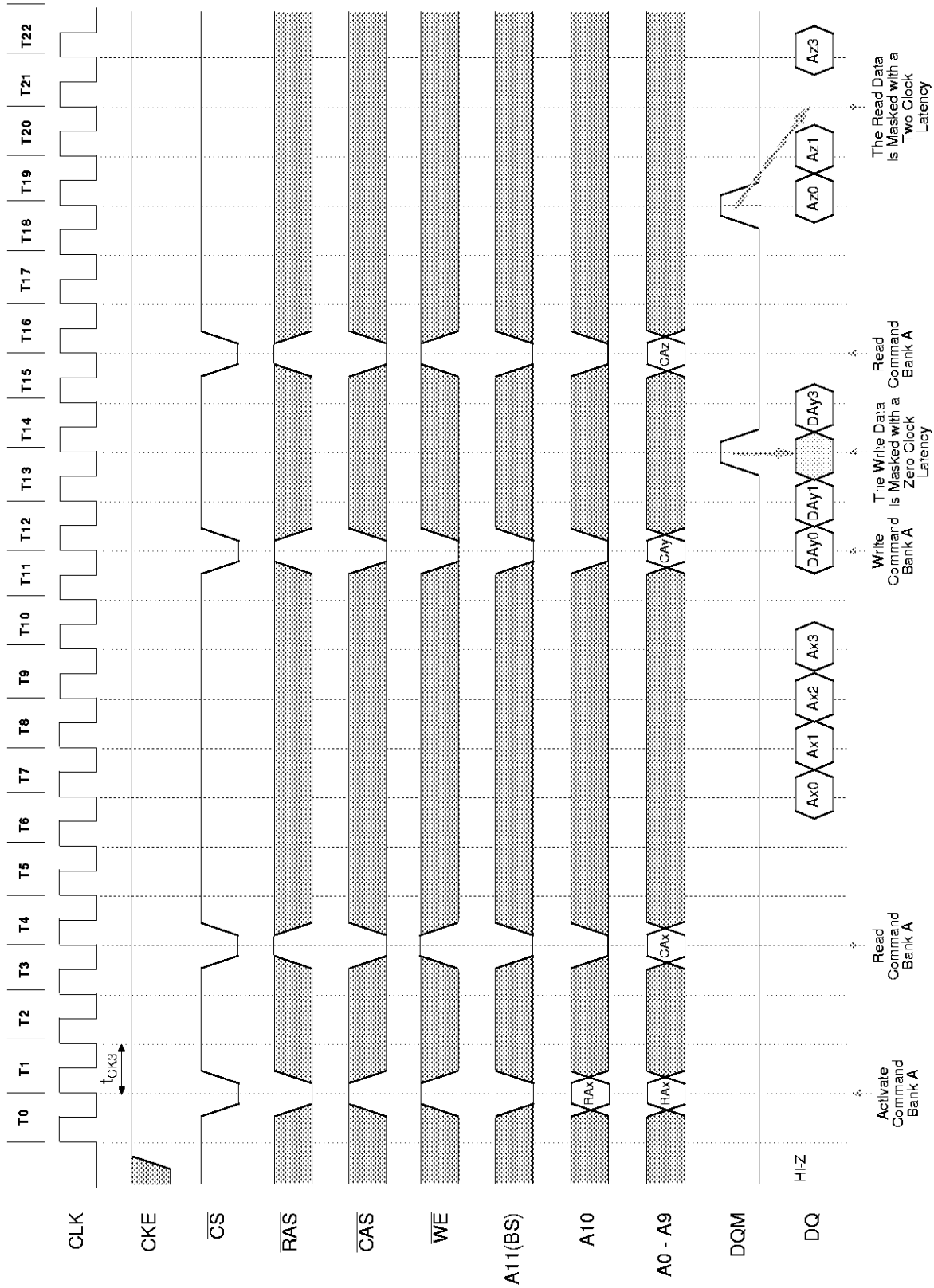



Interleaved Column Read Cycle (1 of 3)

Burst Length = 4, CAS Latency = 1

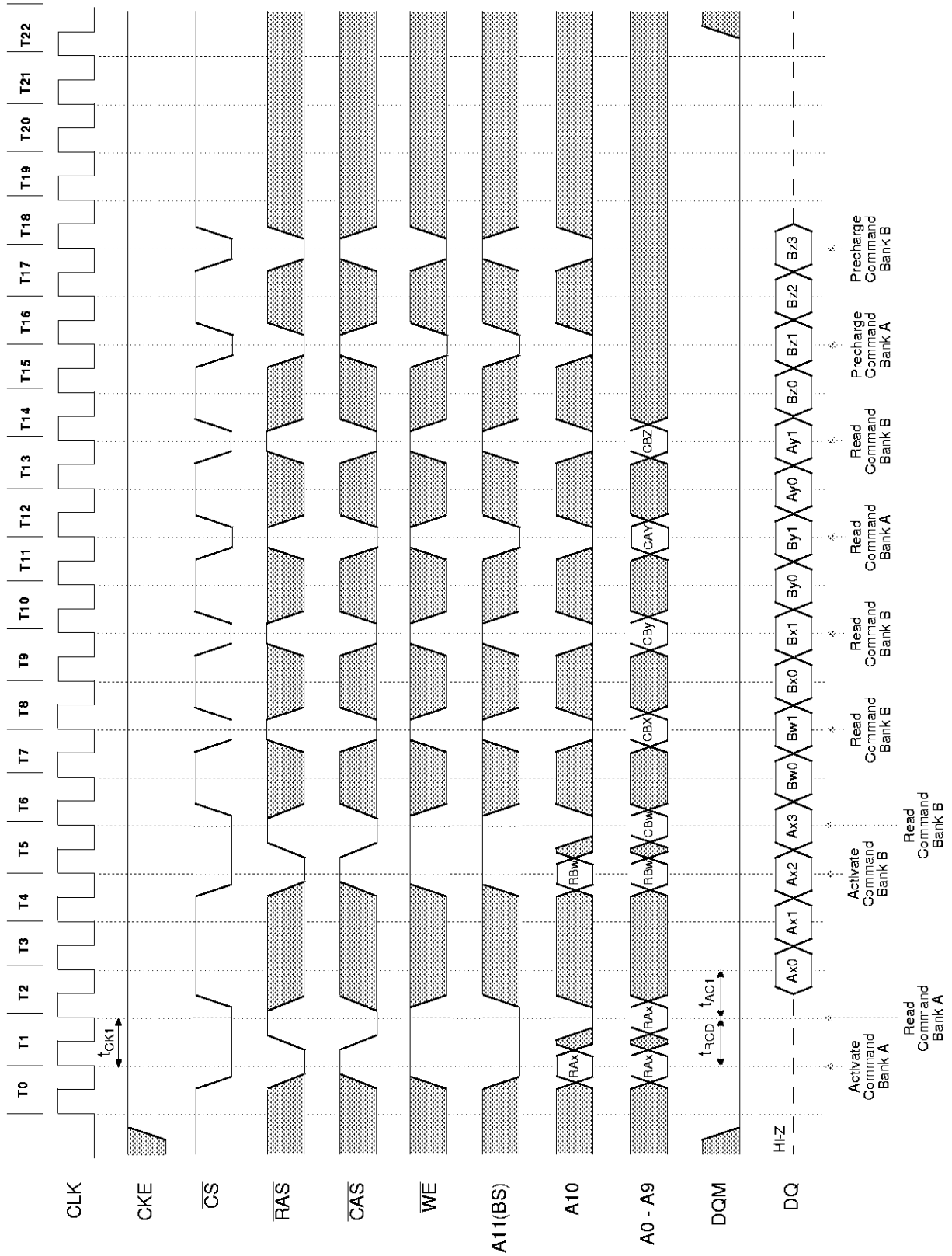



16Mb Synchronous DRAM

Interleaved Column Read Cycle (2 of 3)

Burst Length = 4, CAS Latency = 2

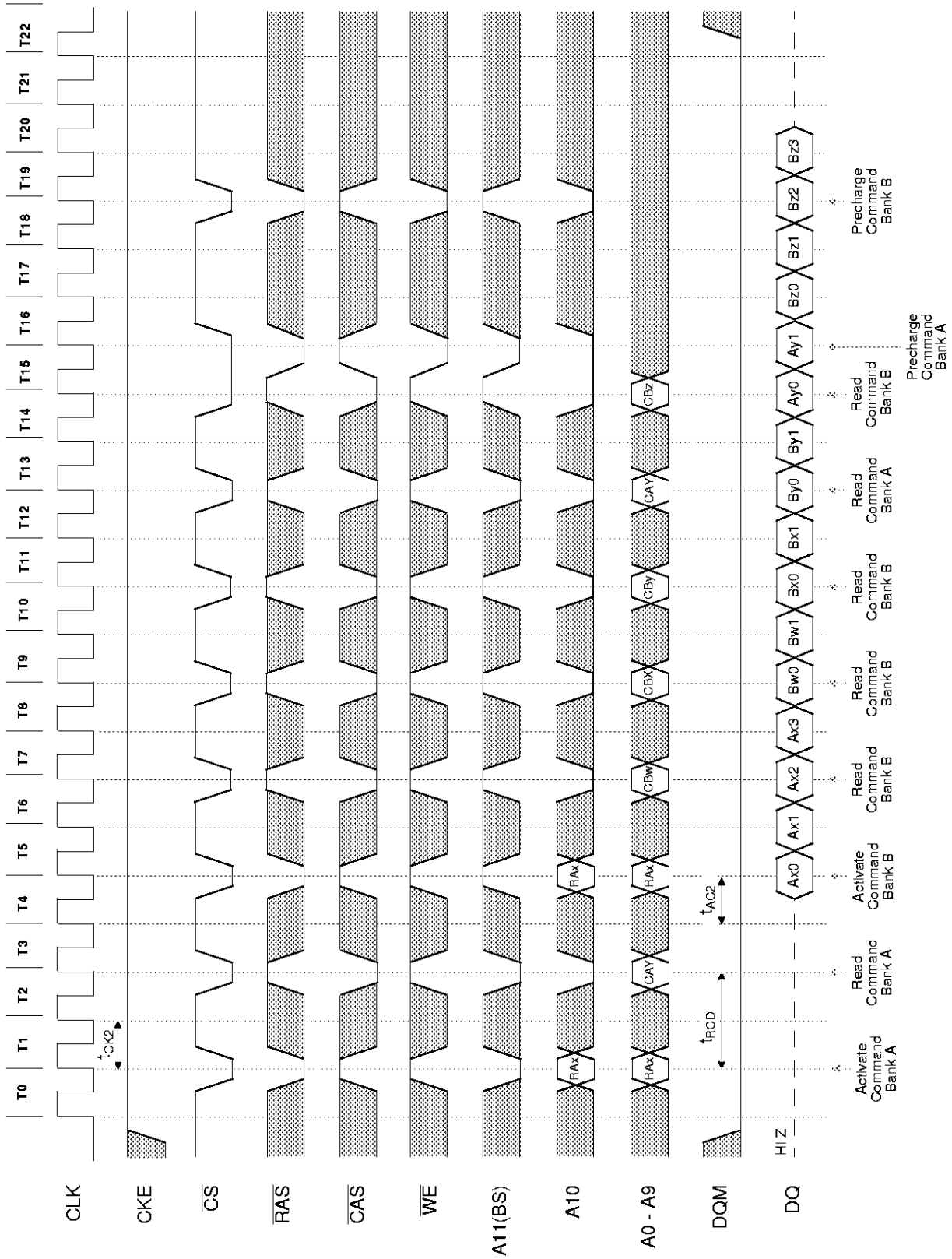



Interleaved Column Read Cycle (3 of 3)

Burst Length = 4, CAS Latency = 3

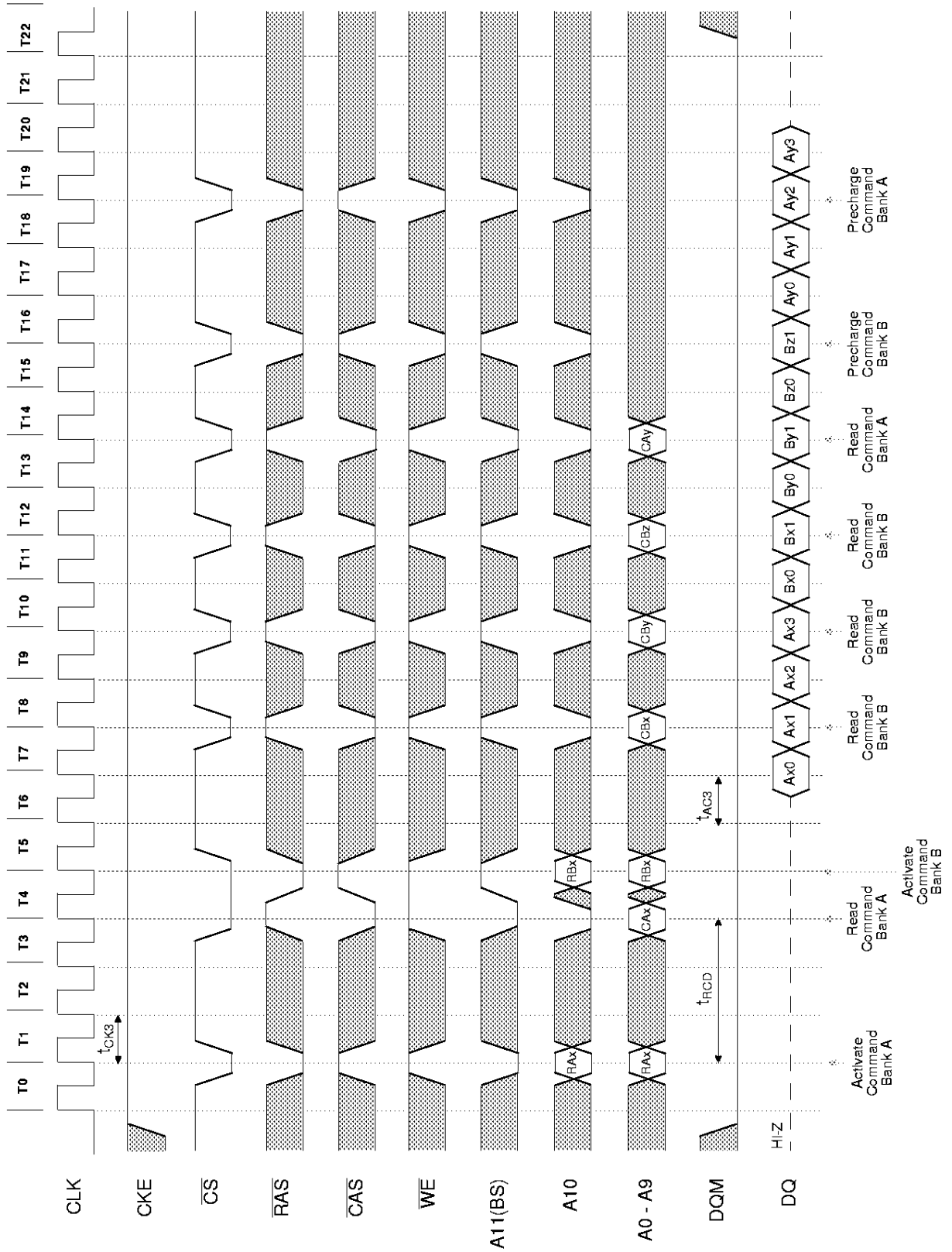



16Mb Synchronous DRAM

Interleaved Column Write Cycle (1 of 3)

Burst Length = 4, CAS Latency = 1

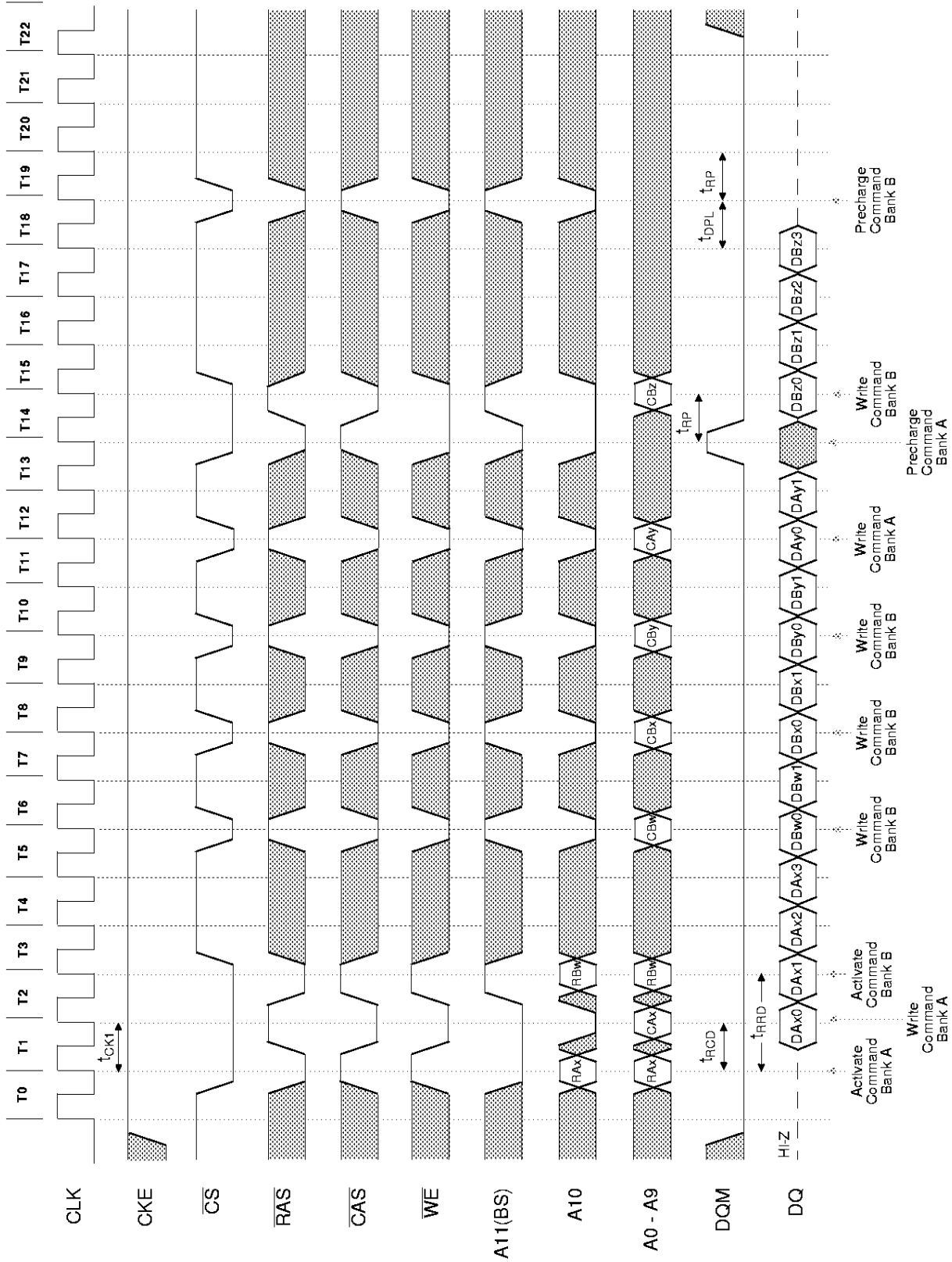



Interleaved Column Write Cycle (2 of 3)

Burst Length = 4, CAS Latency = 2

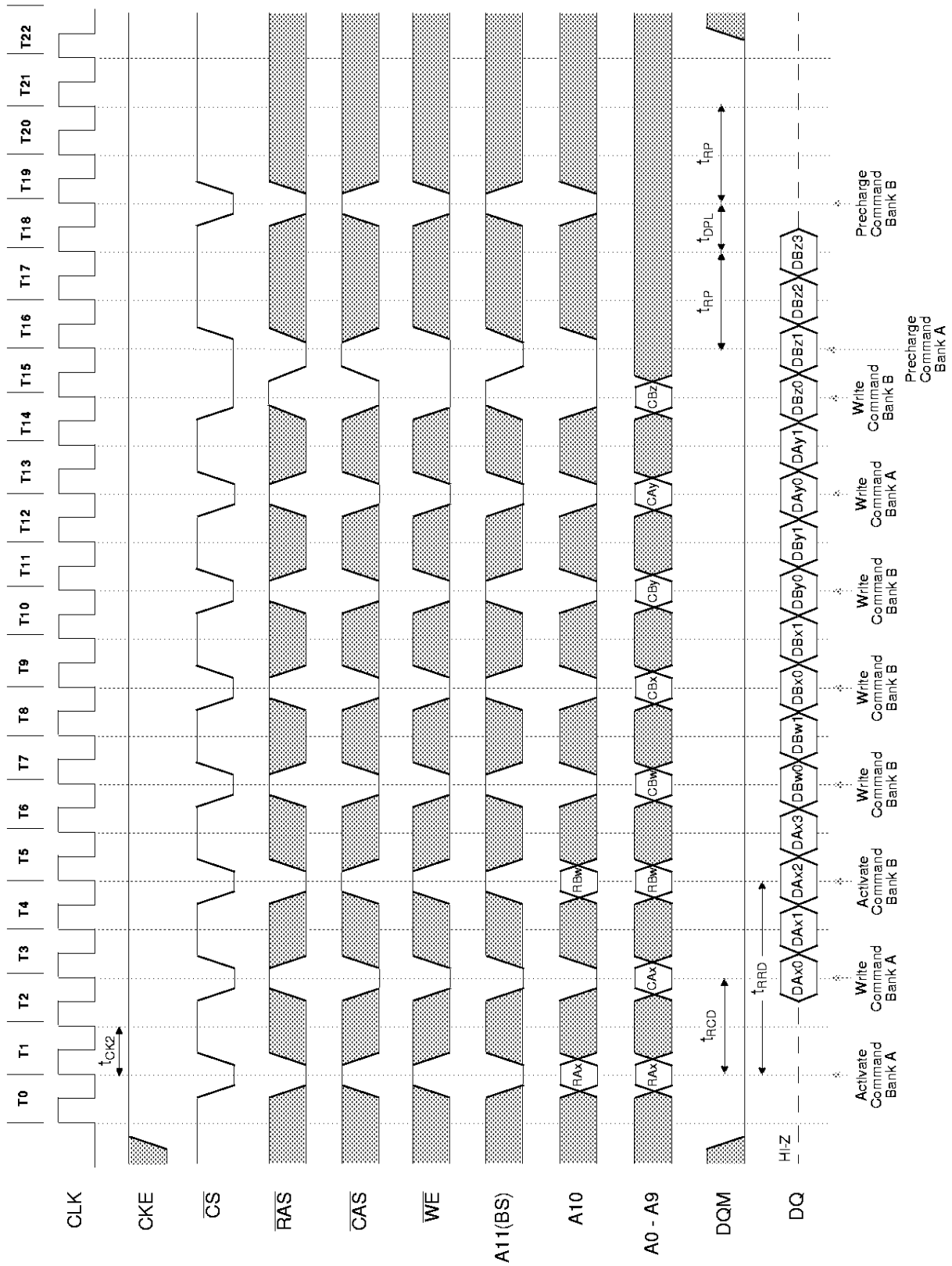



16Mb Synchronous DRAM

Interleaved Column Write Cycle (3 of 3)

Burst Length = 4, CAS Latency = 3

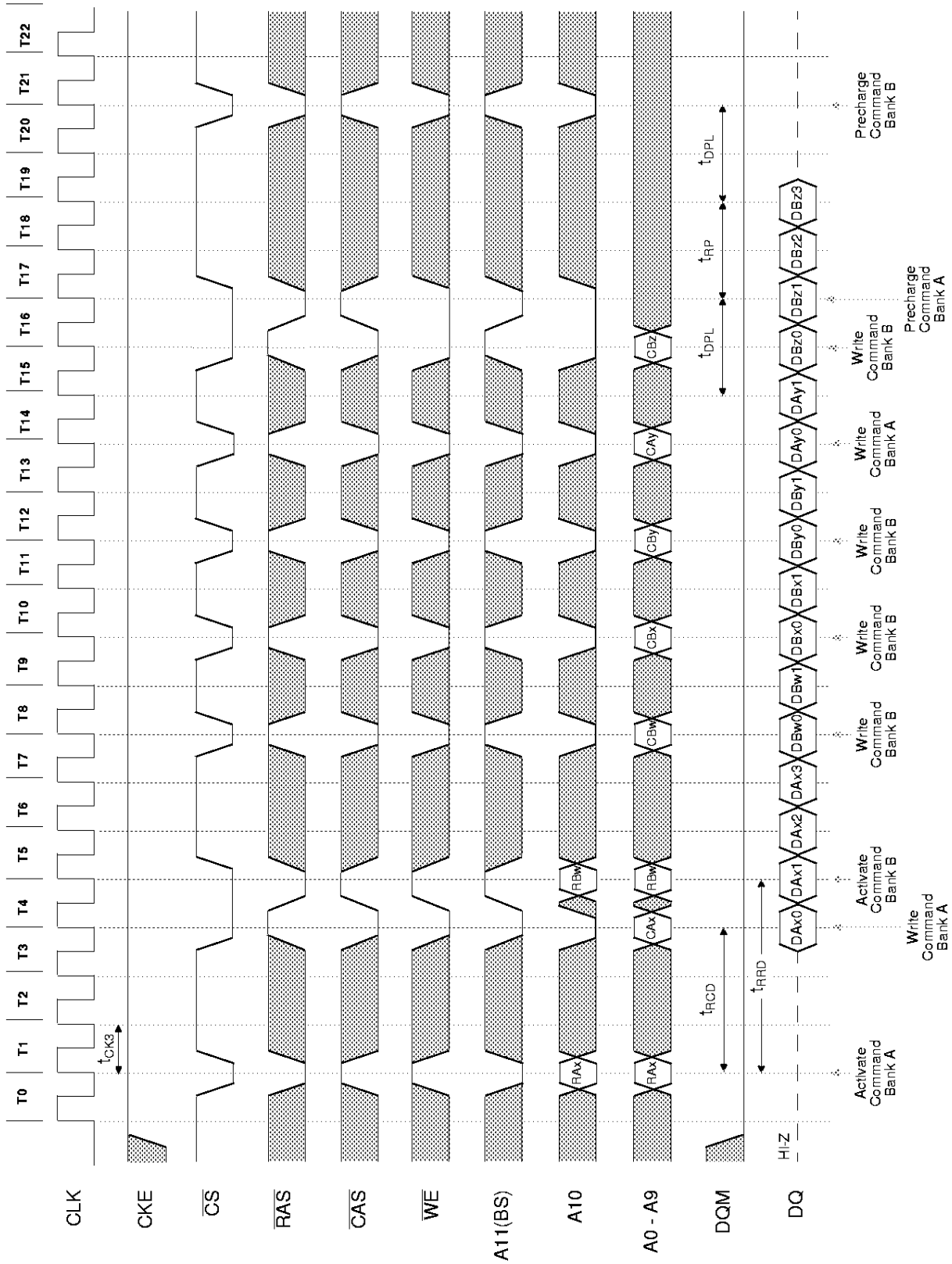



Auto Precharge after Read Burst (1 of 3)

Burst Length = 4, CAS Latency = 1

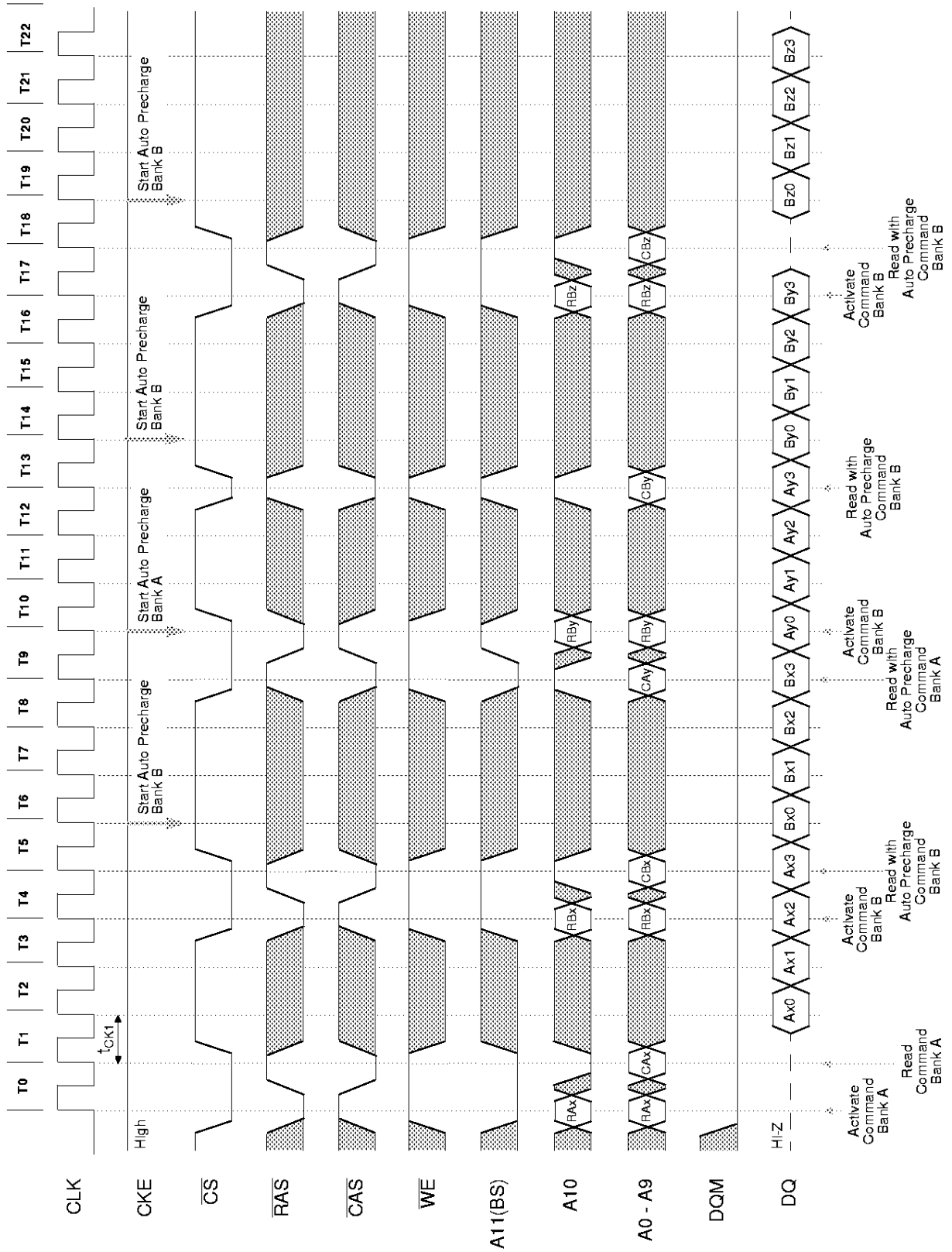



16Mb Synchronous DRAM

Burst Length = 4, CAS Latency = 2

Auto Precharge after Read Burst (2 of 3)

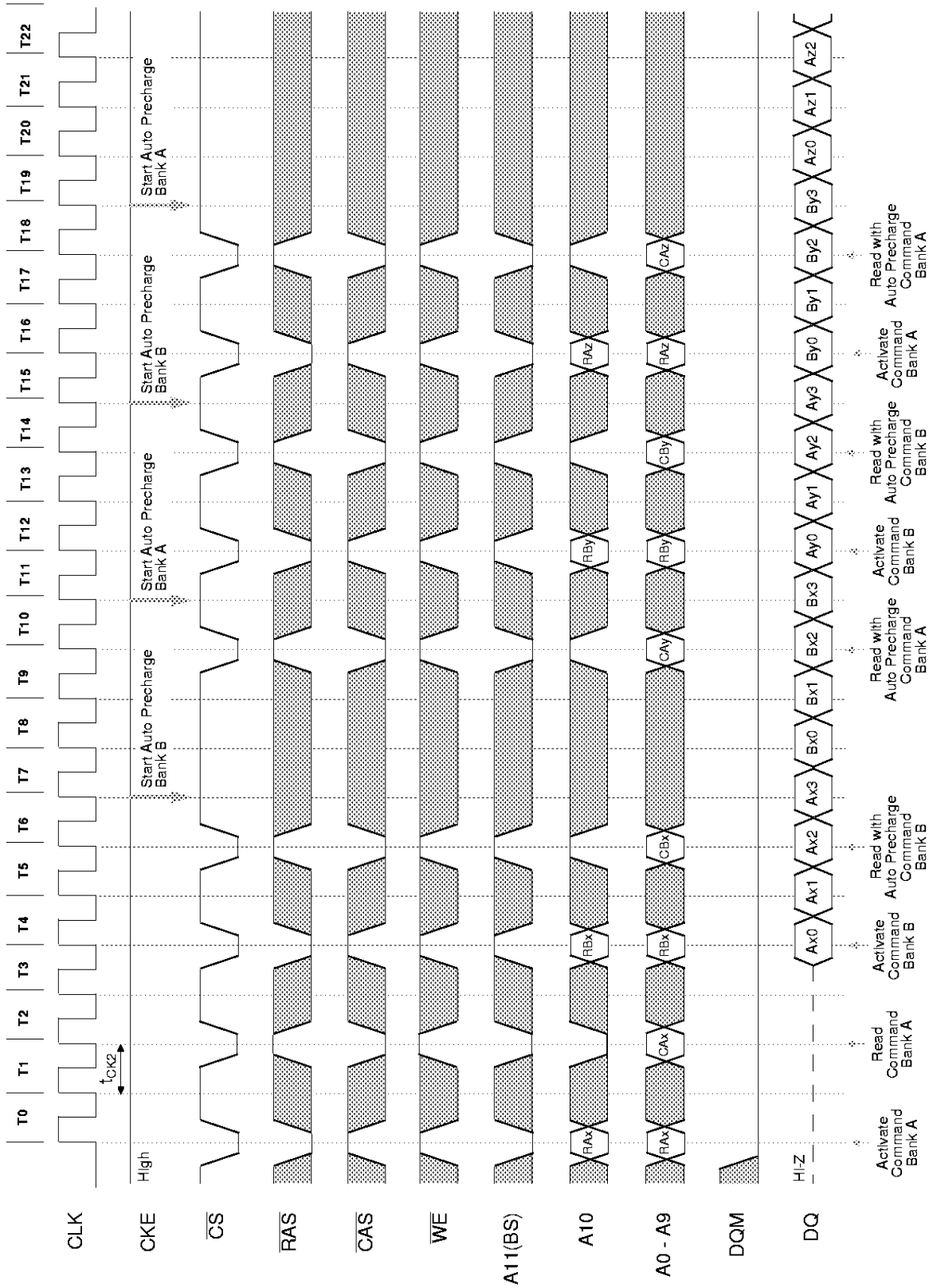



Auto Precharge after Read Burst (3 of 3)

Burst Length = 4, CAS Latency = 3

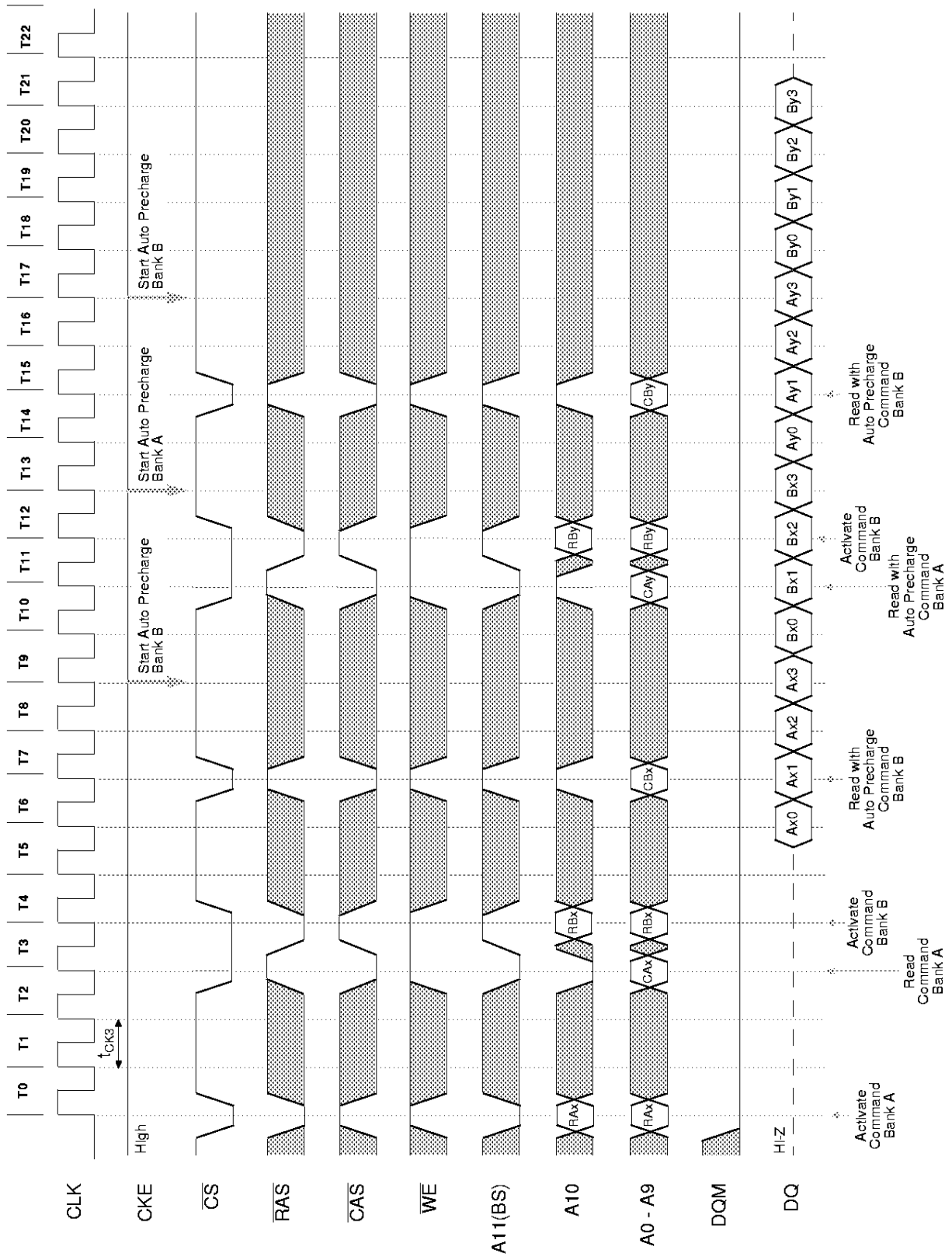



16Mb Synchronous DRAM

Auto Precharge after Write Burst (1 of 3)

Burst Length = 4, CAS Latency = 1

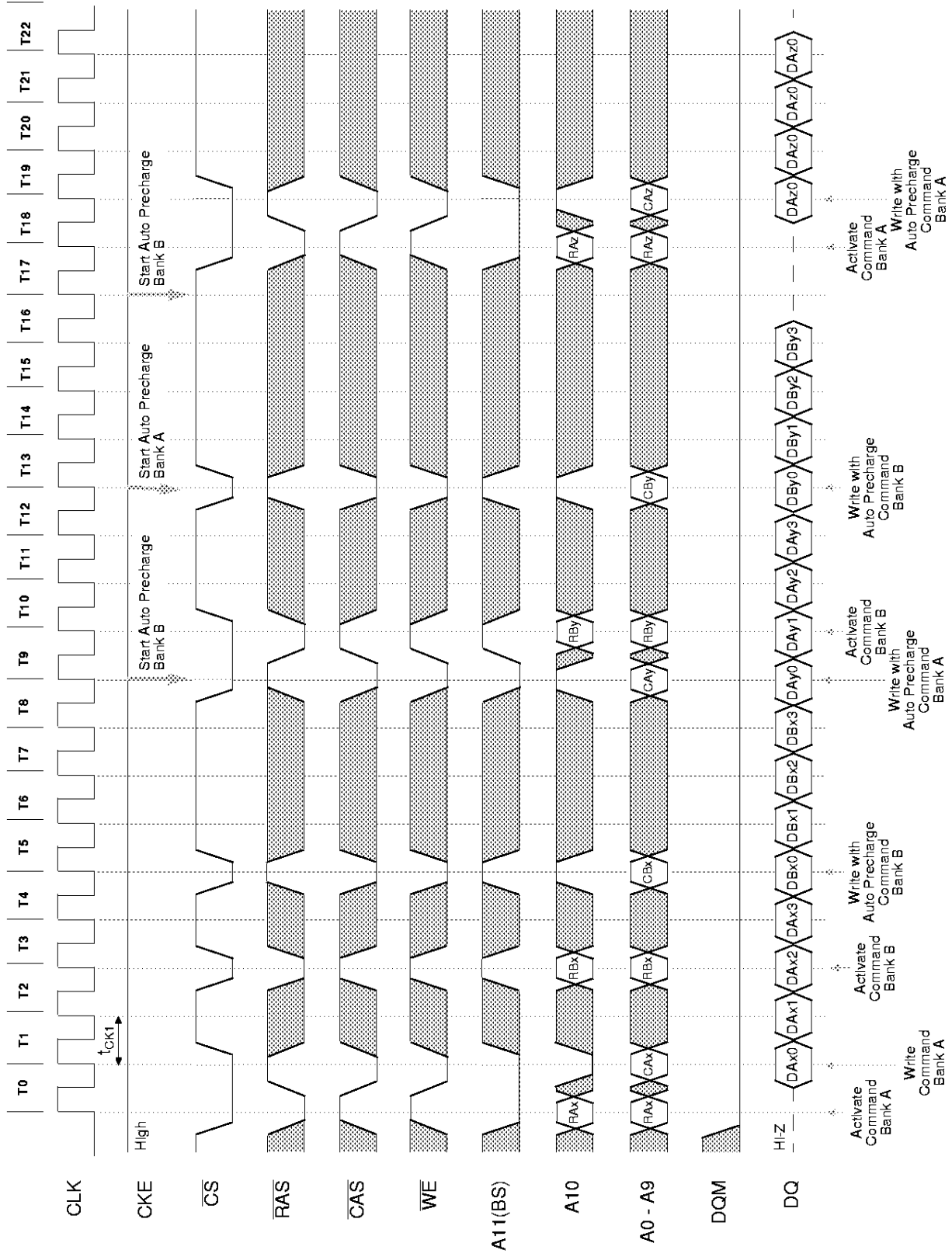



Auto Precharge after Write Burst (2 of 3)

Burst Length = 4, CAS Latency = 2

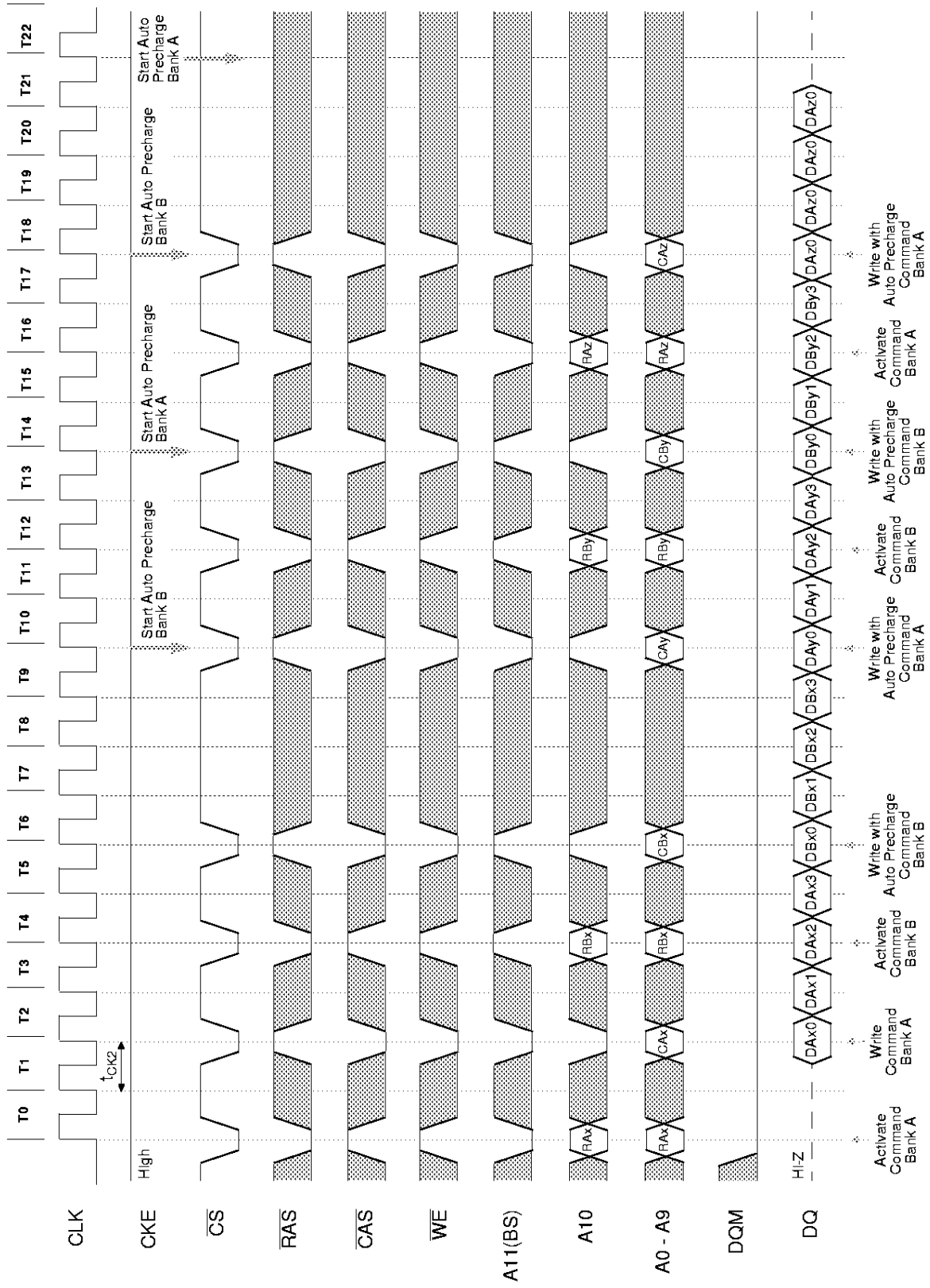



16Mb Synchronous DRAM

Auto Precharge after Write Burst (3 of 3)

Burst Length = 4, CAS Latency = 3

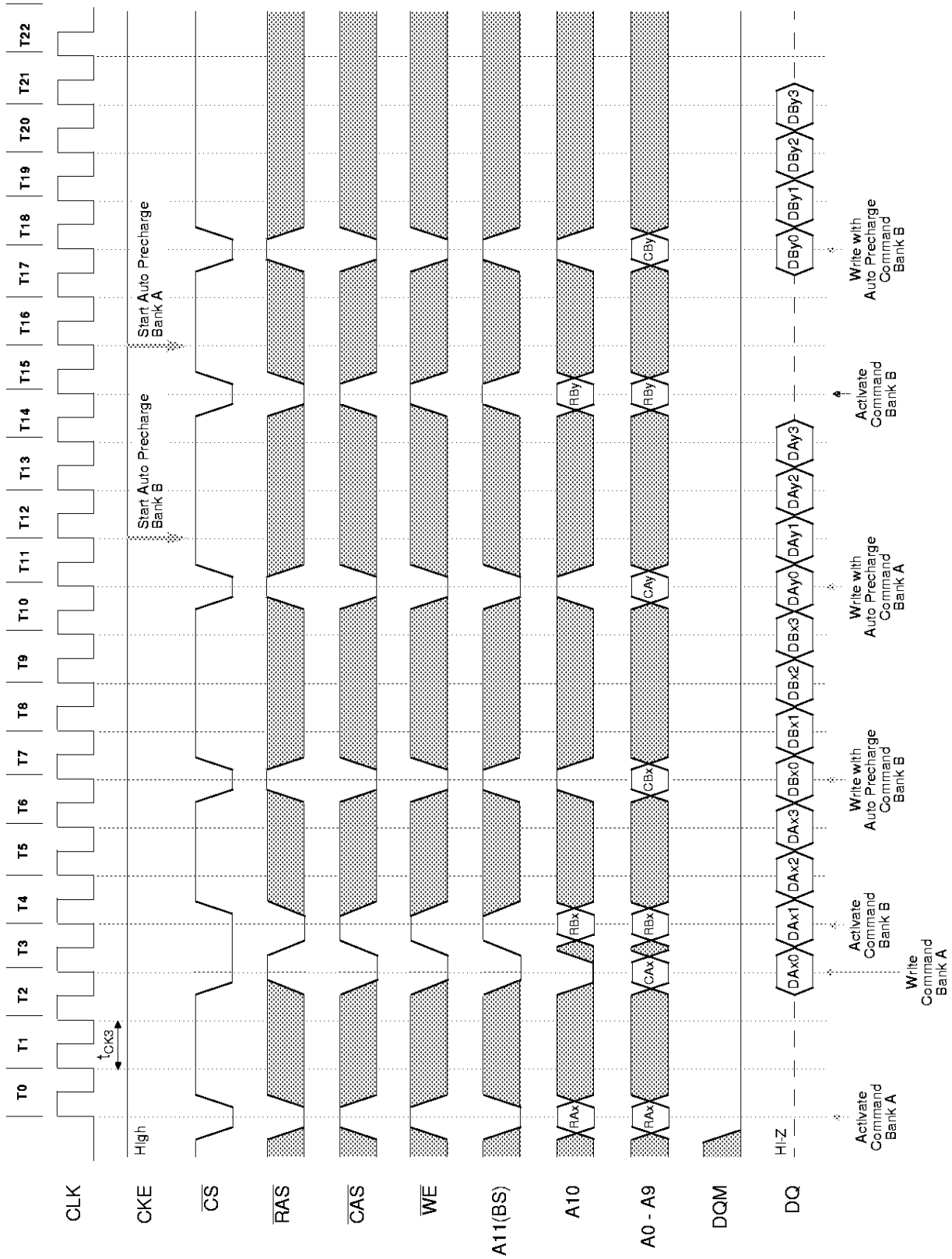



Full Page Read Cycle (1 of 3)

Burst Length = Full Page, CAS Latency = 1

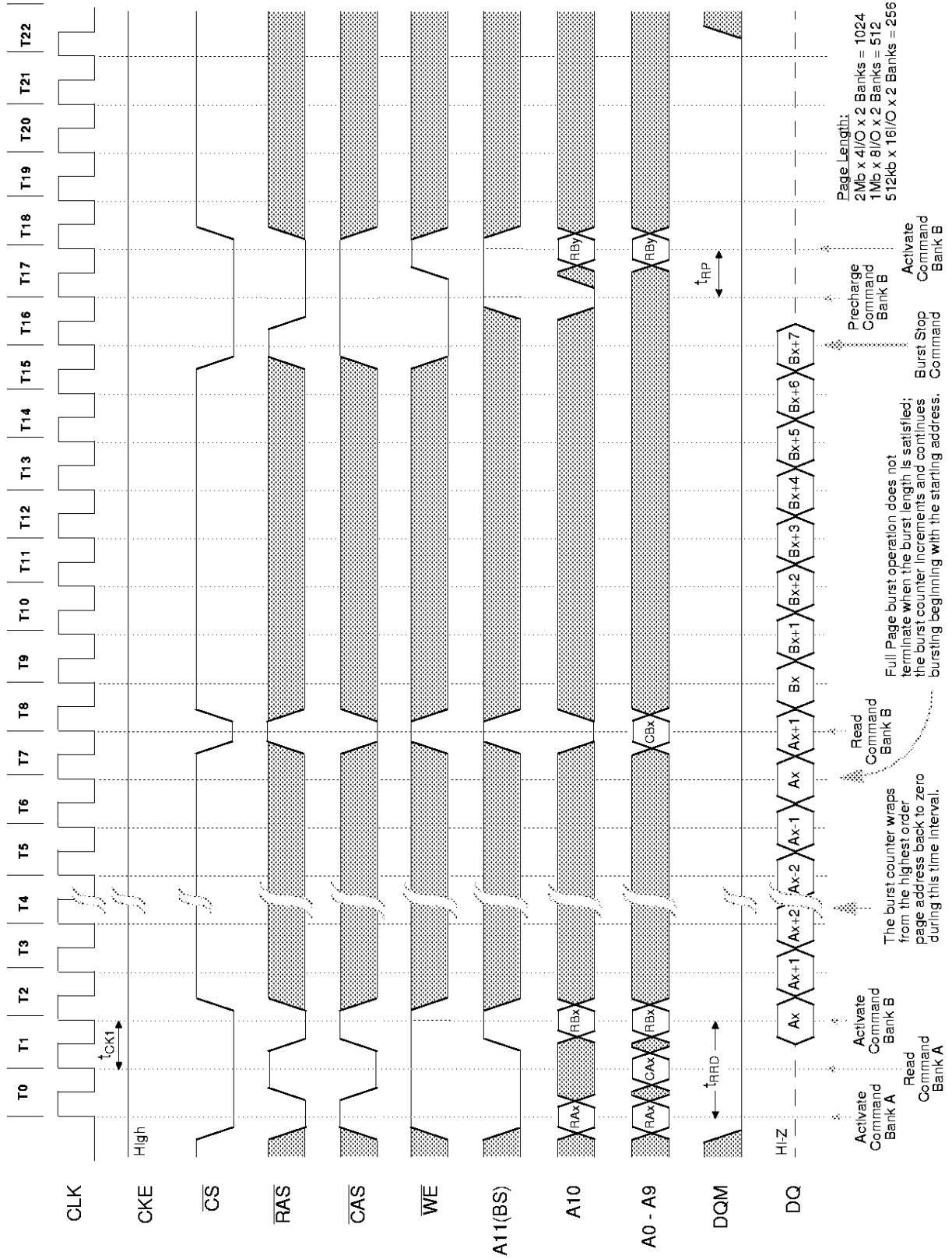



16Mb Synchronous DRAM

Burst Length = Full Page, CAS Latency = 2

Full Page Read Cycle (2 of 3)

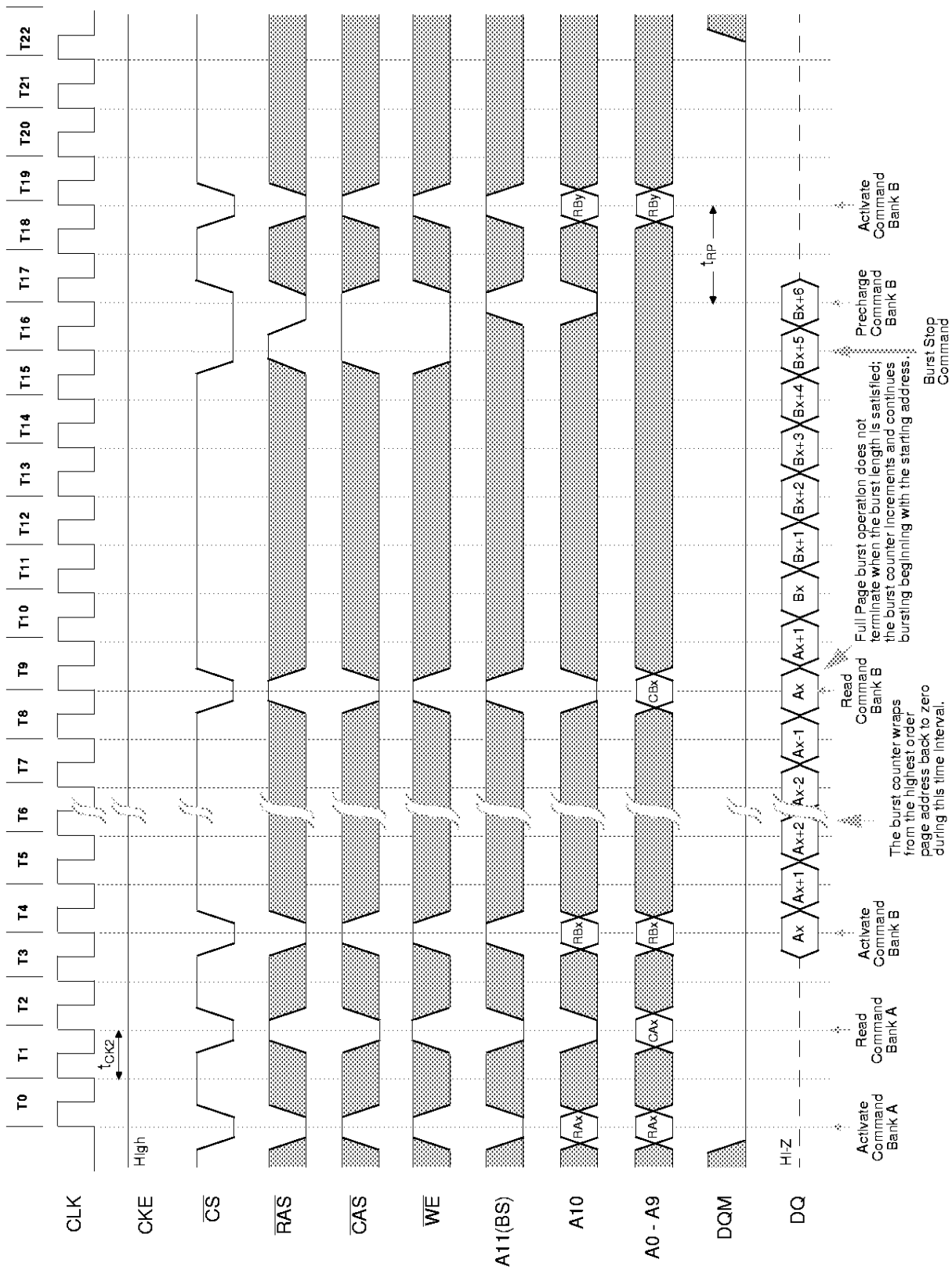



Full Page Read Cycle (3 of 3)

Burst Length = Full Page, CAS Latency = 3

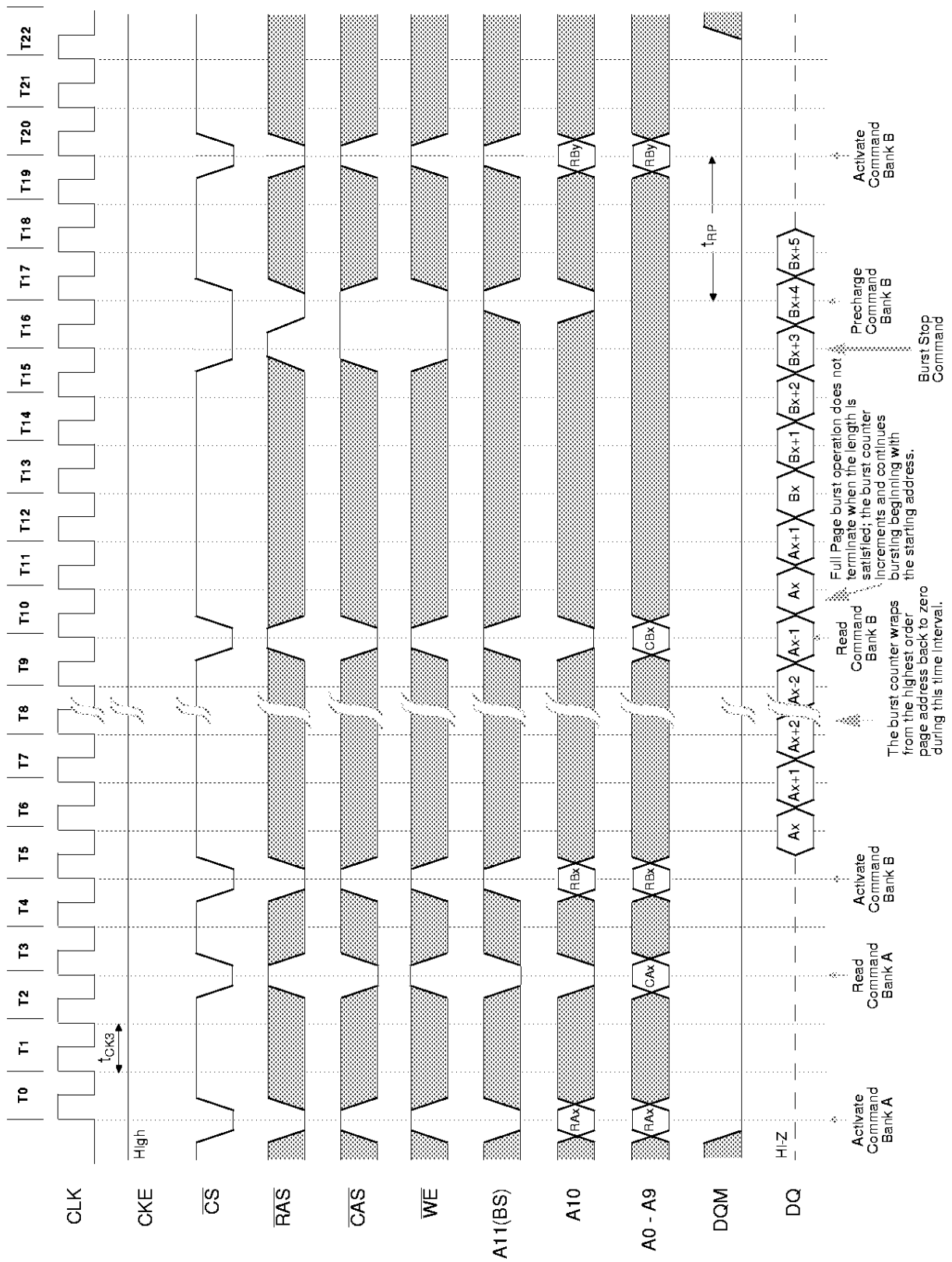



Full Page Write Cycle (1 of 3)

Burst Length = Full Page, CAS Latency = 1

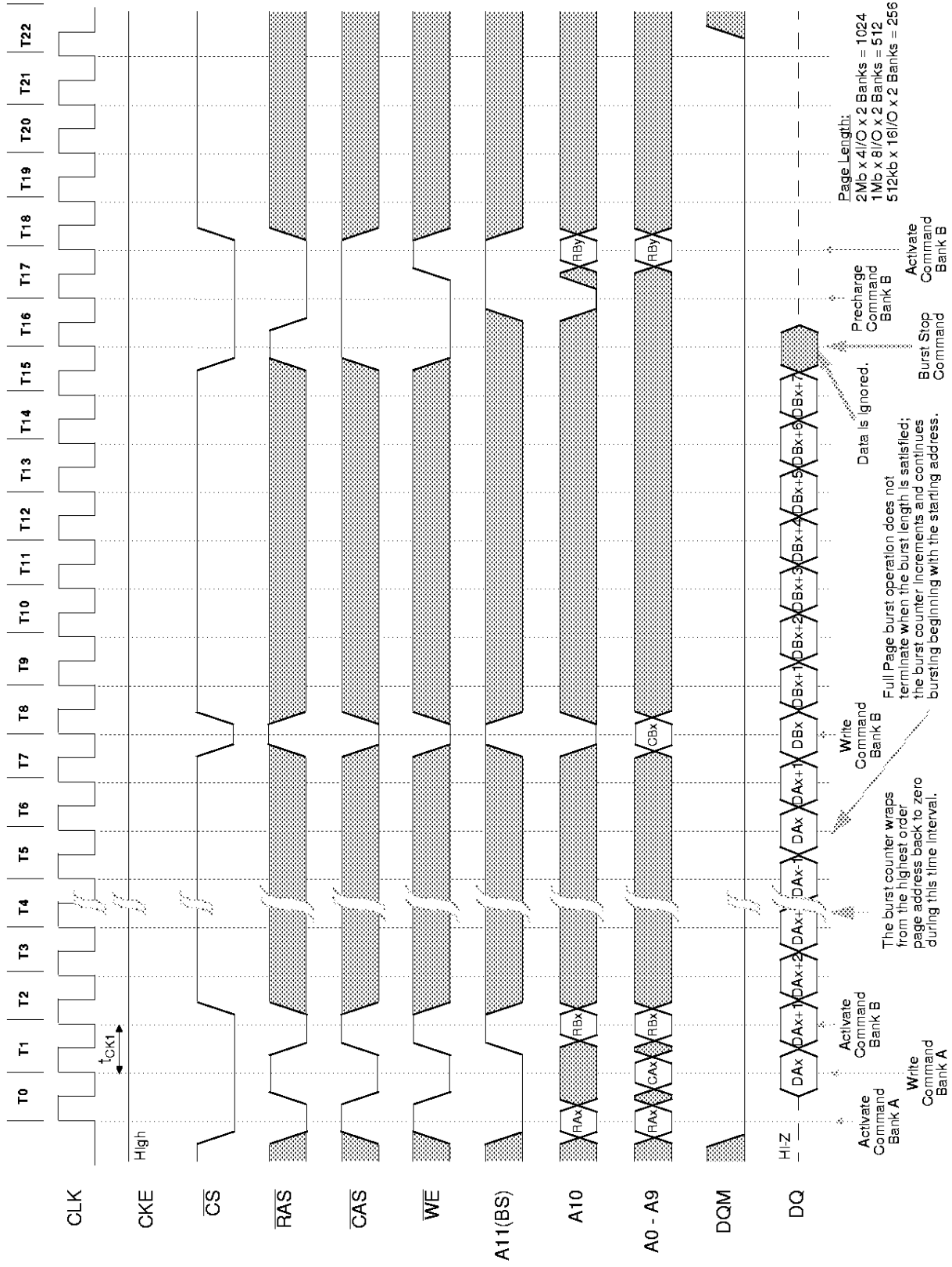



Full Page Write Cycle (2 of 3)

Burst Length = Full Page, CAS Latency = 2

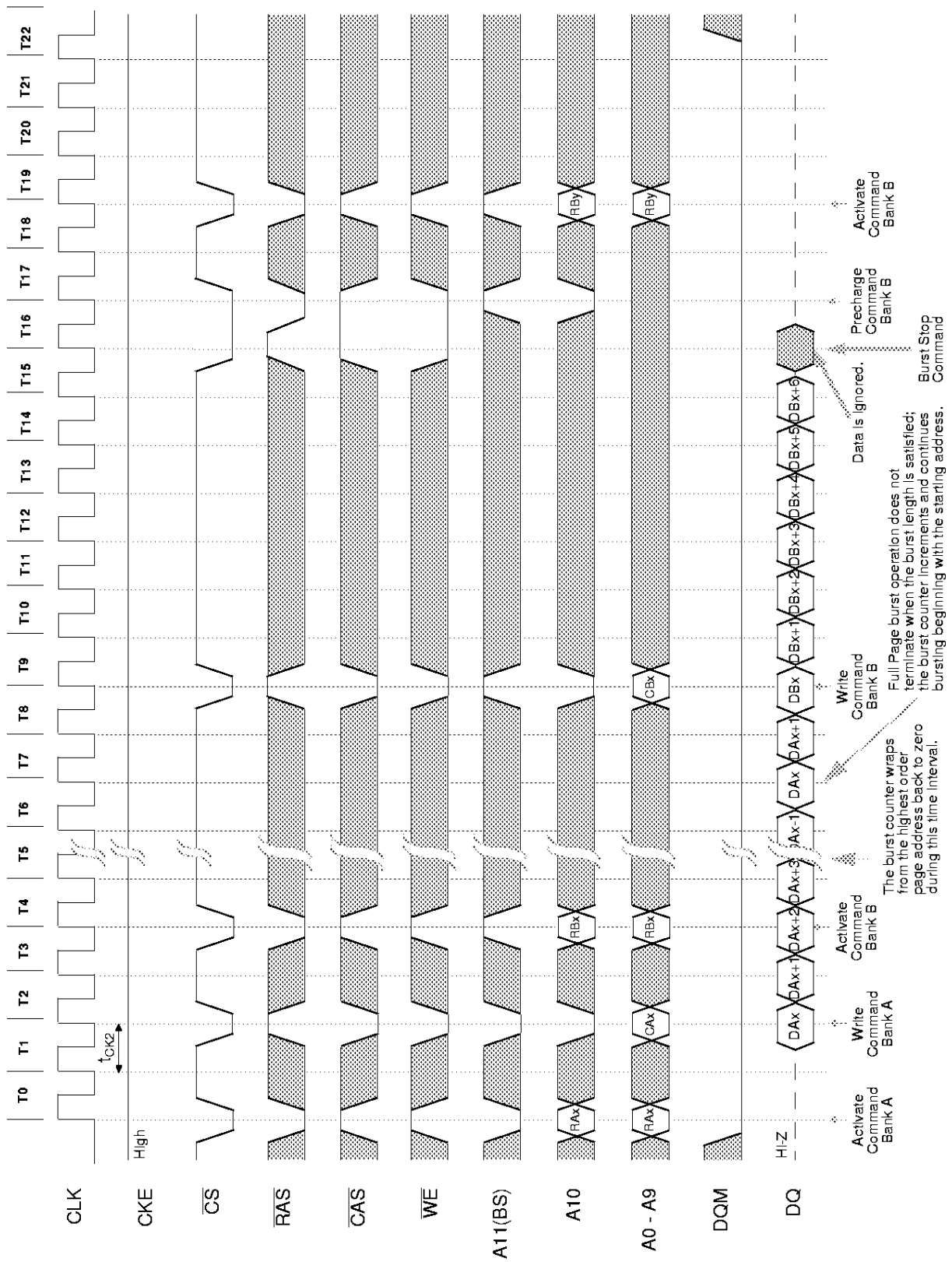



16Mb Synchronous DRAM

Burst Length = Full Page, CAS Latency = 3

Full Page Write Cycle (3 of 3)

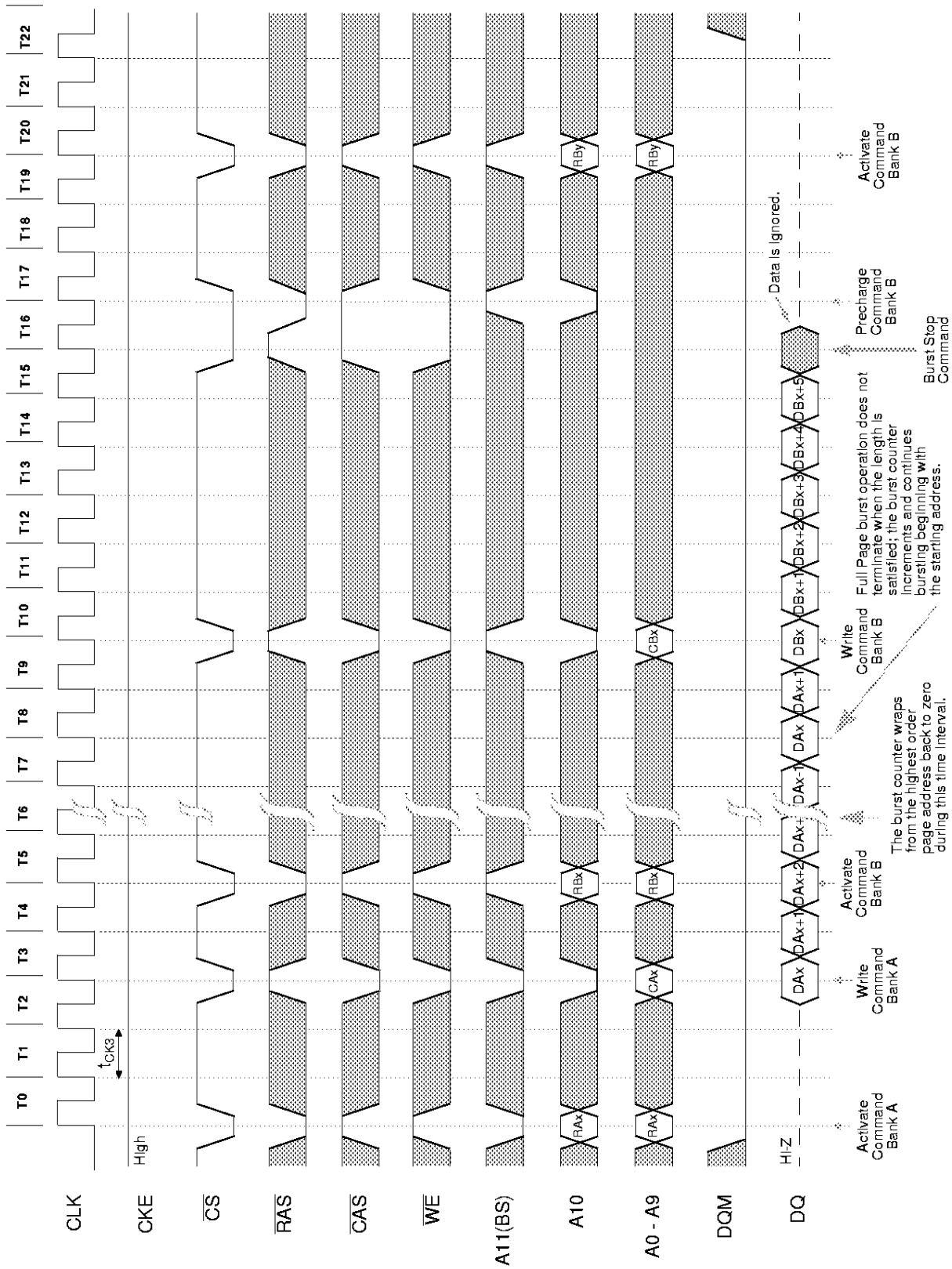



Burst Length = 4, CAS Latency = 2

Byte Write Operation

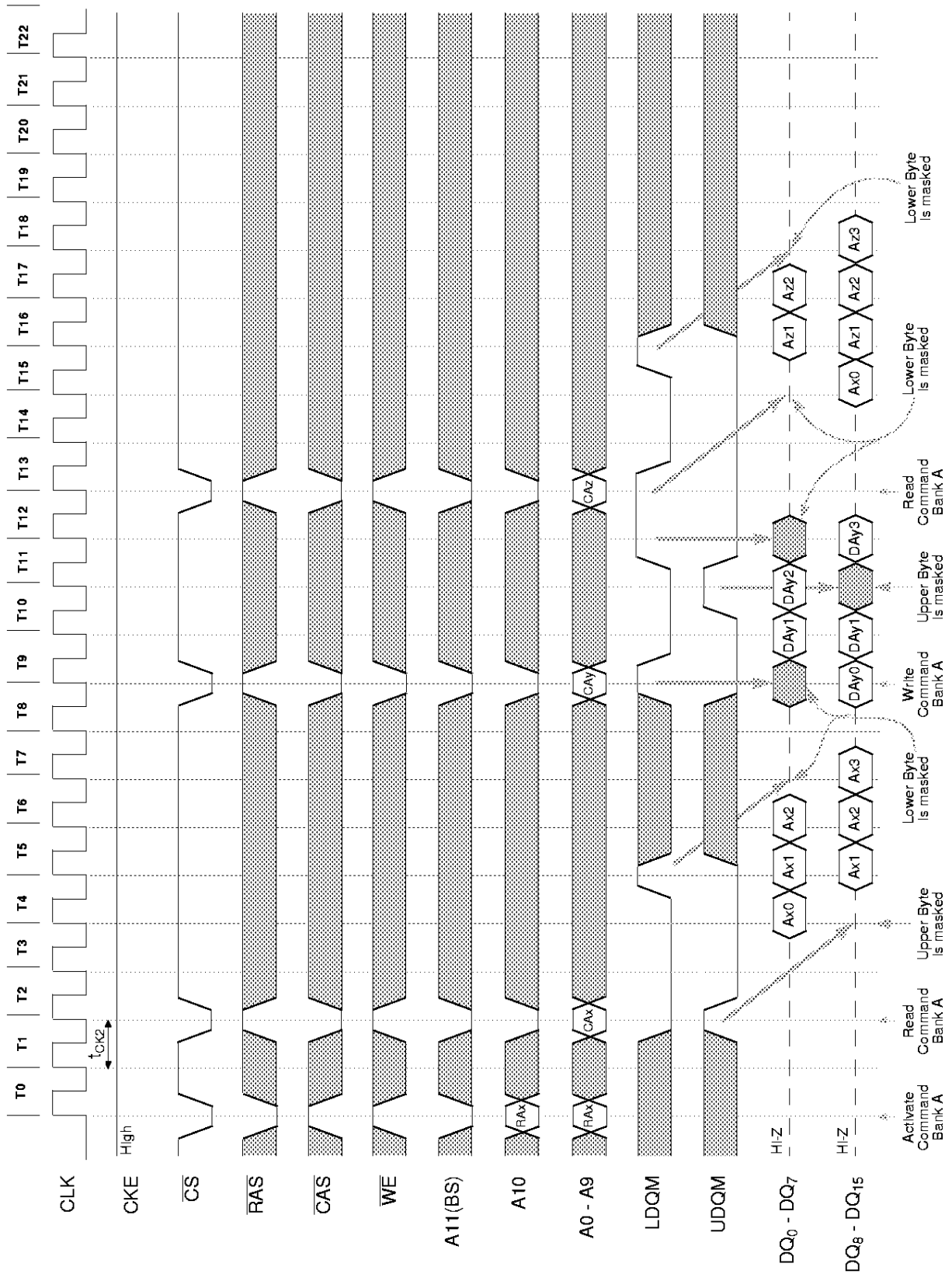



16Mb Synchronous DRAM

Burst Length = 4, CAS Latency = 2

Burst Read and Single Write Operation

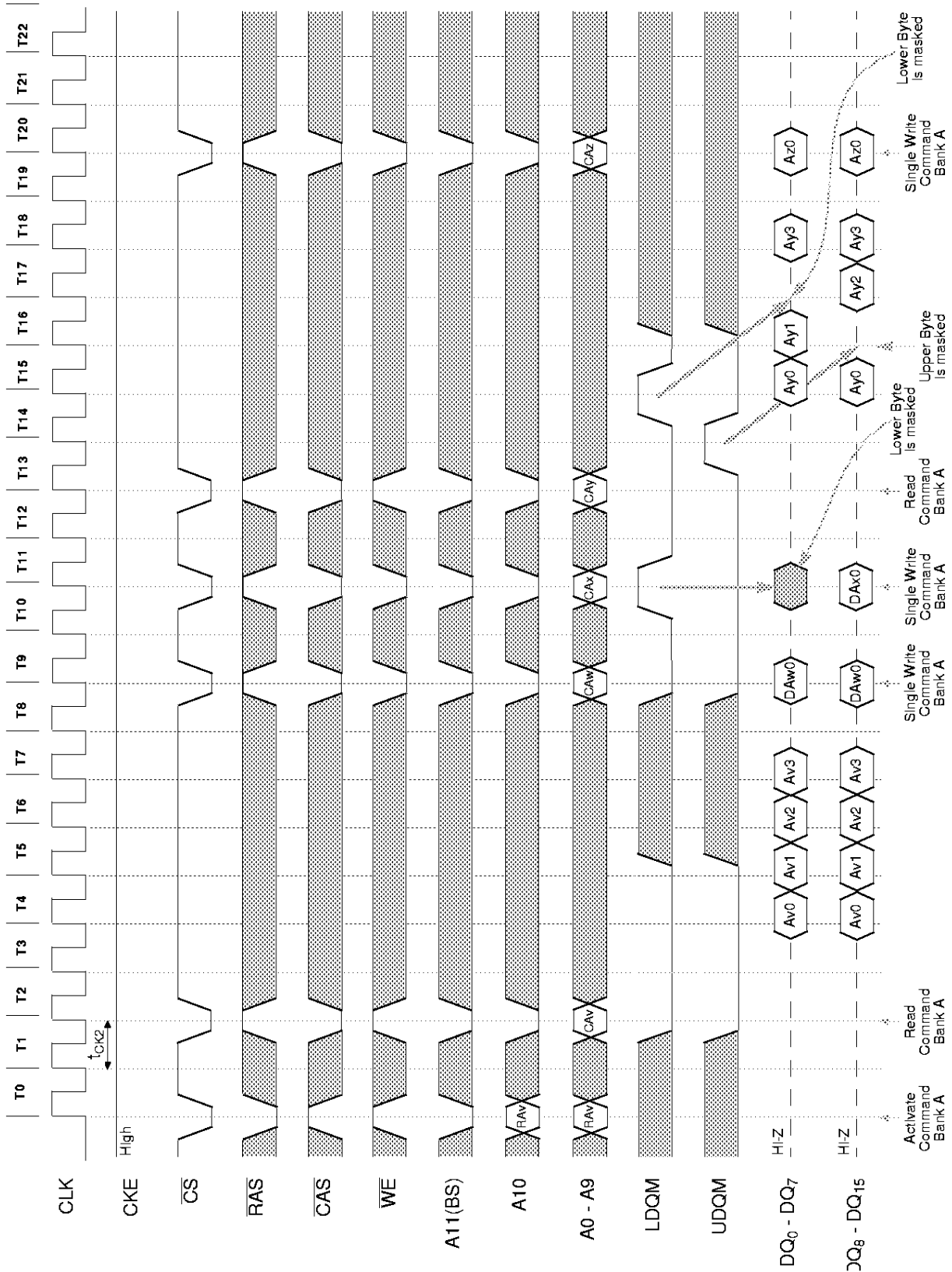



16Mb Synchronous DRAM

Random Row Read (Interleaving Banks)

Burst Length = 2, CAS Latency = 1

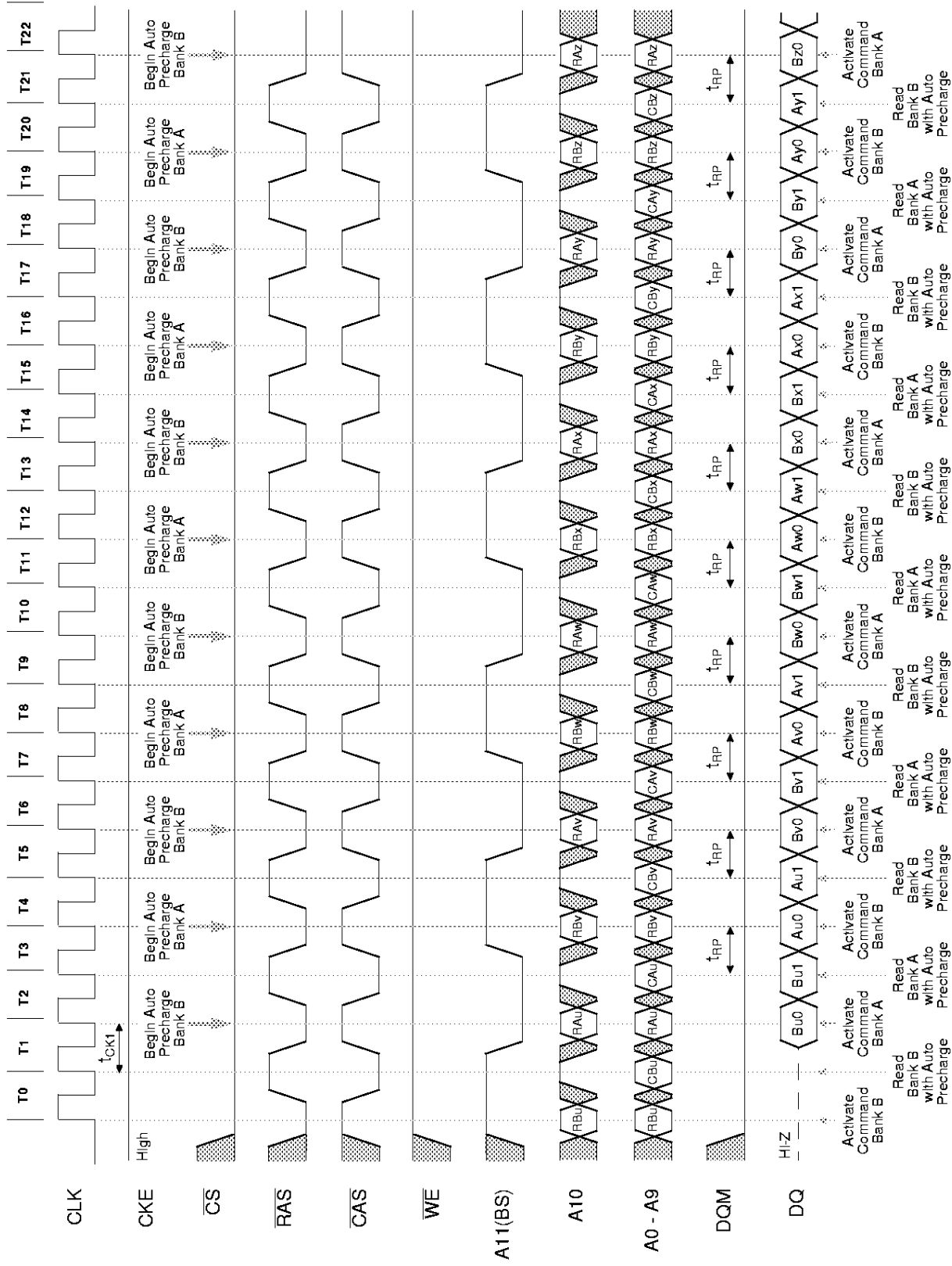



16Mb Synchronous DRAM

Burst Length = Full Page, CAS Latency = 2

Full Page Random Column Write

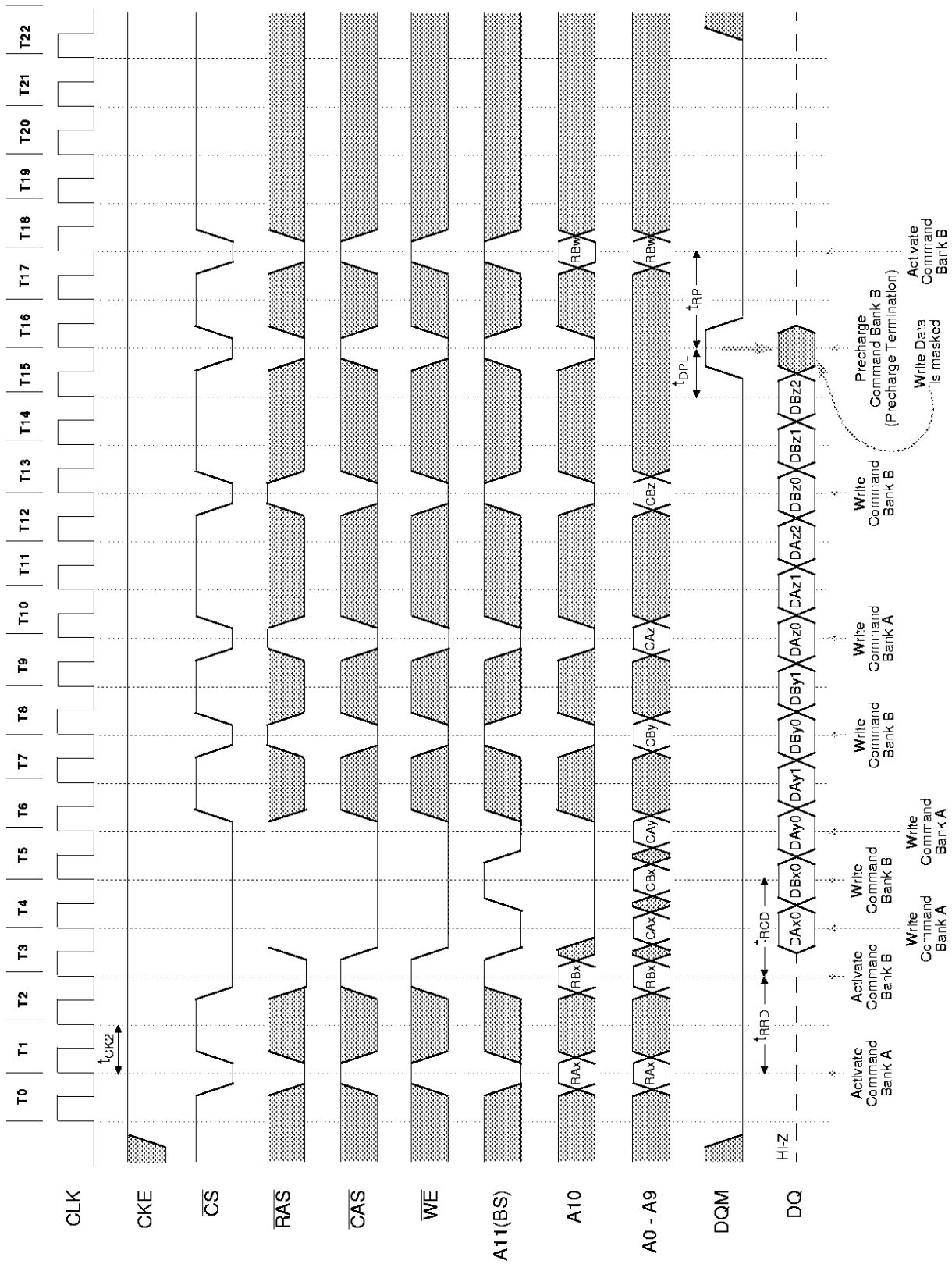

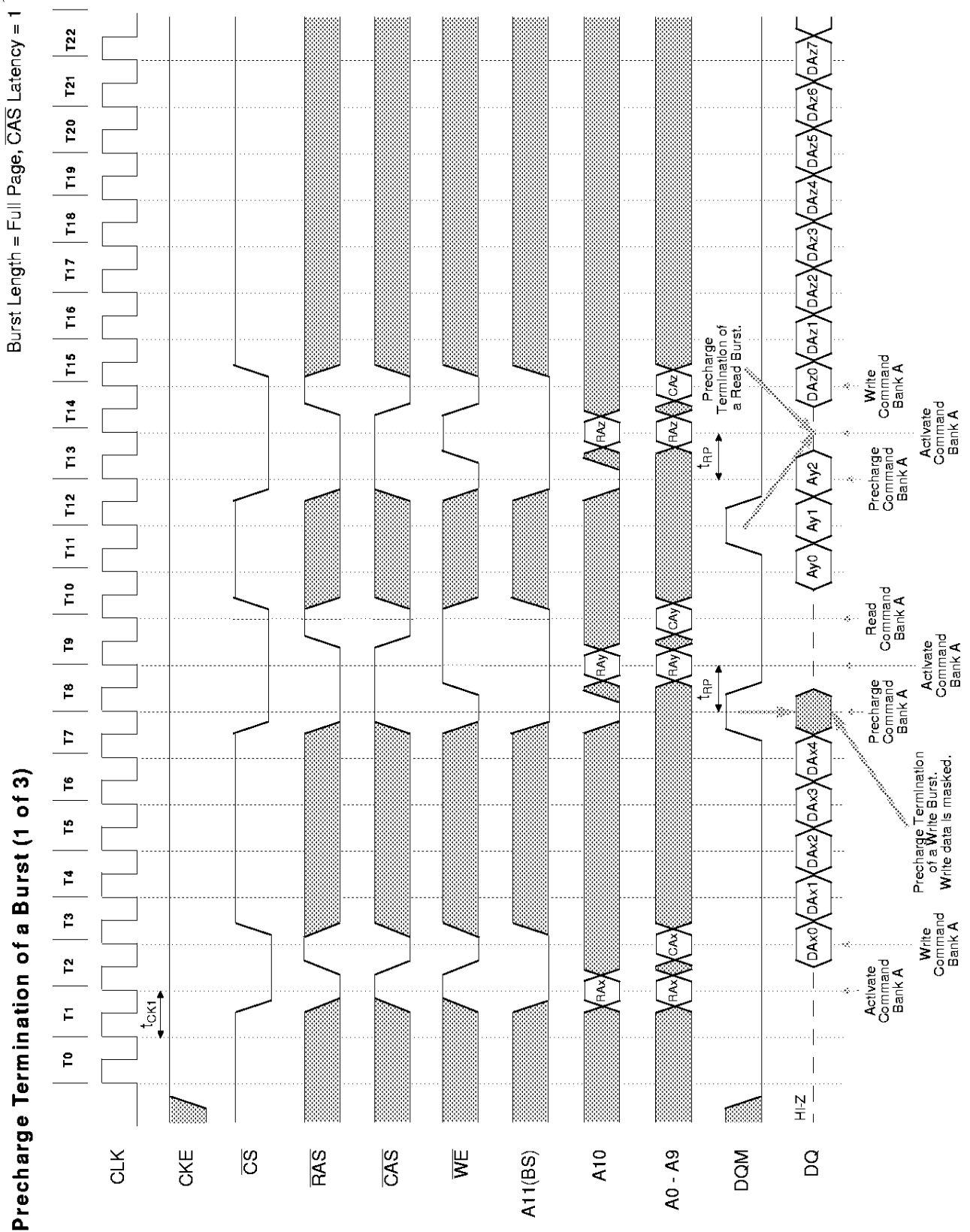



16Mb Synchronous DRAM

Burst Length = 8 or Full Page, CAS Latency = 2

Precharge Termination of a Burst (2 of 3)

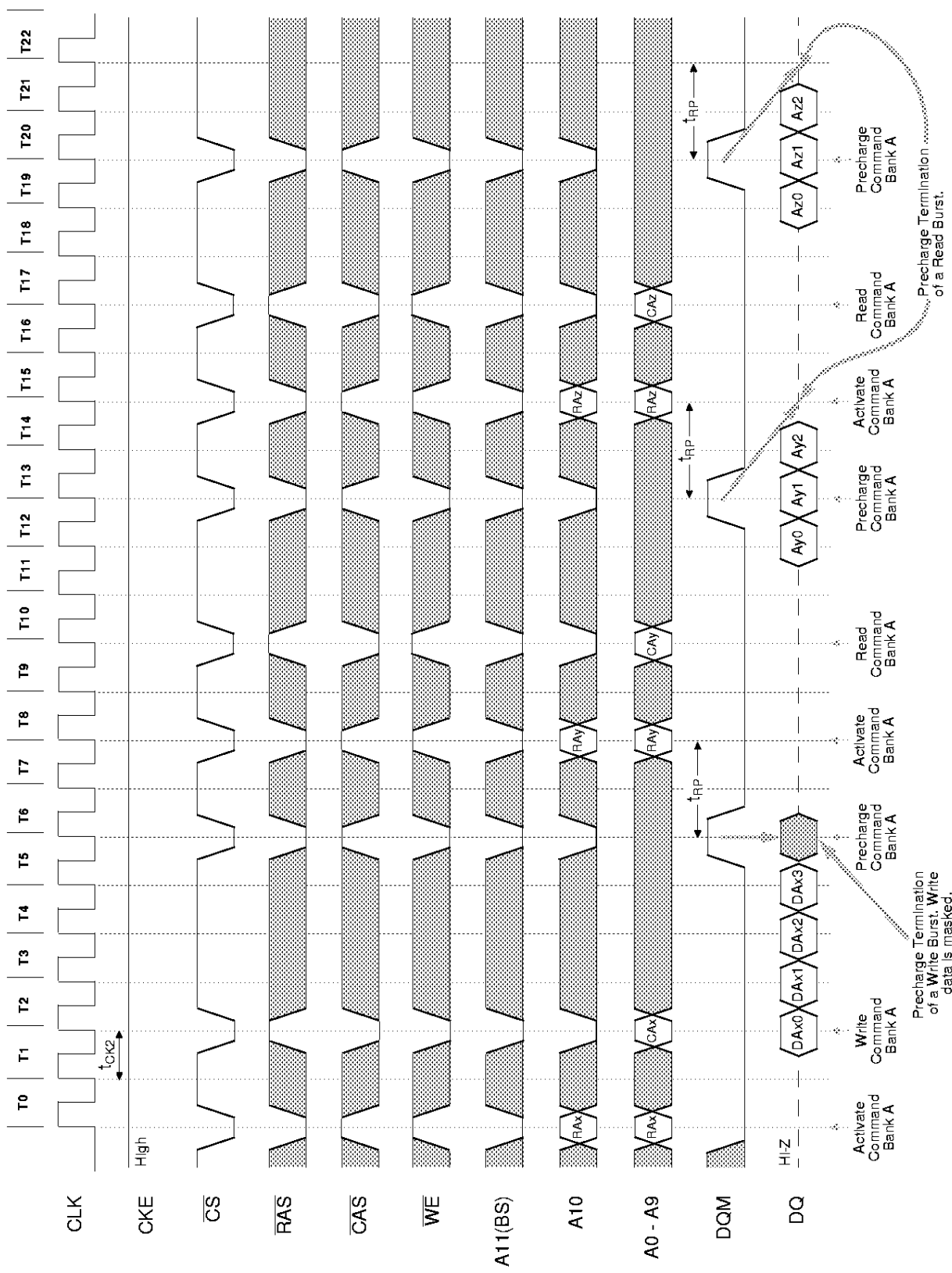

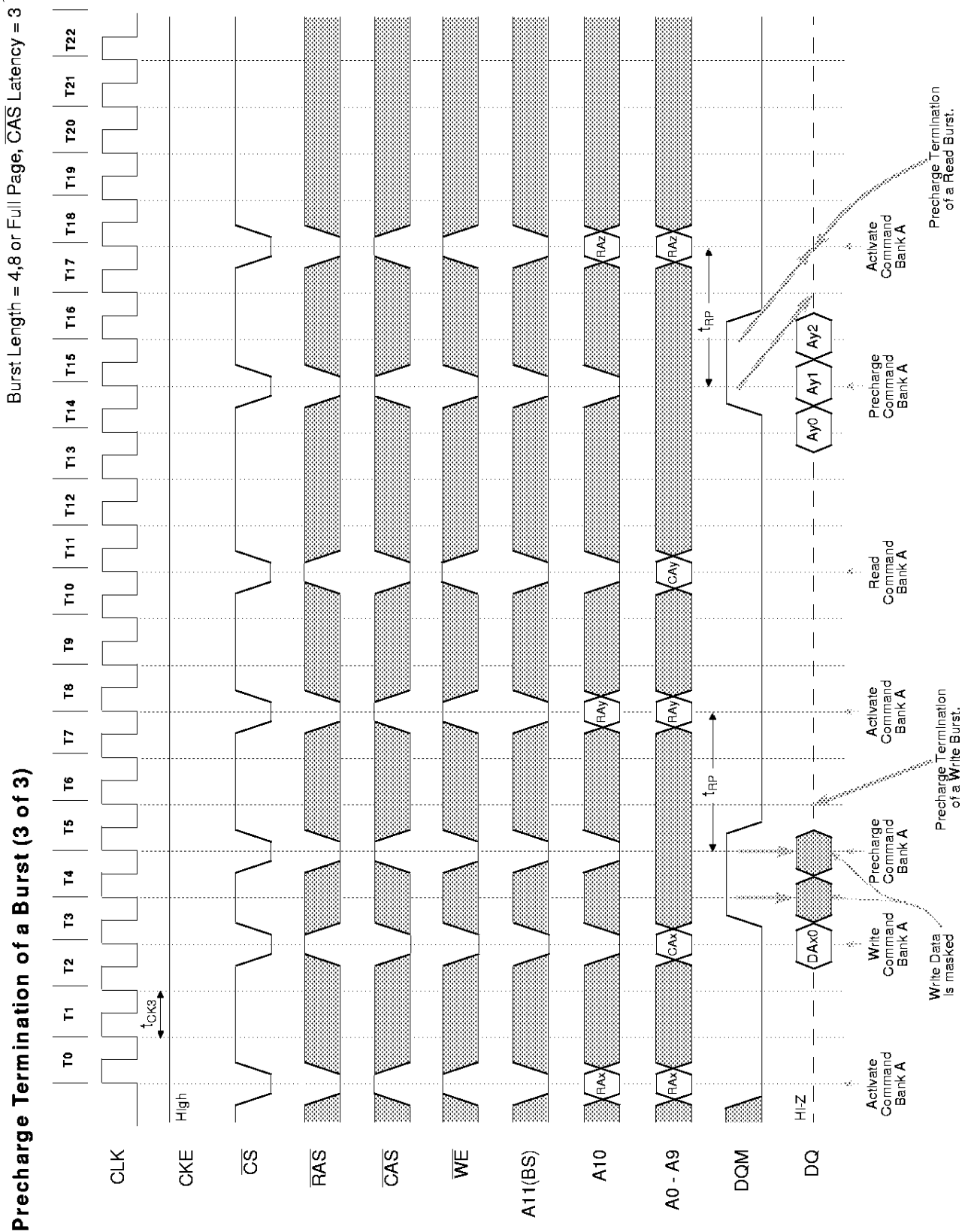



16Mb Synchronous DRAM

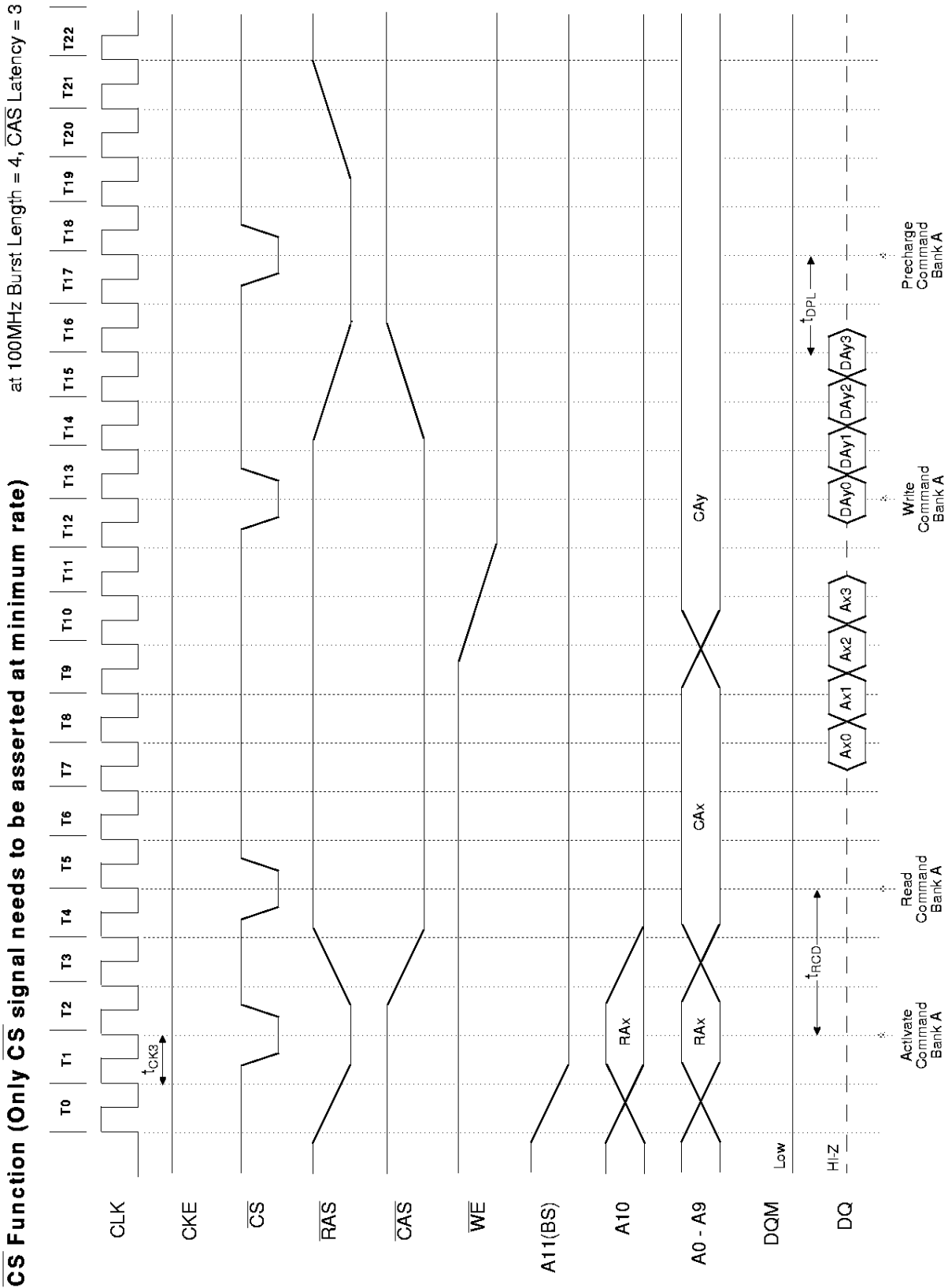

PACKAGE DIMENSIONS (400mil; 44 lead; Thin Small Outline Package)

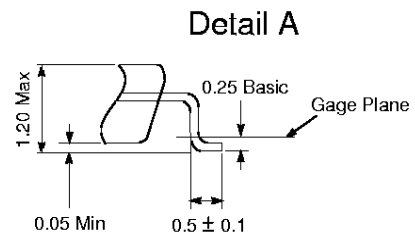
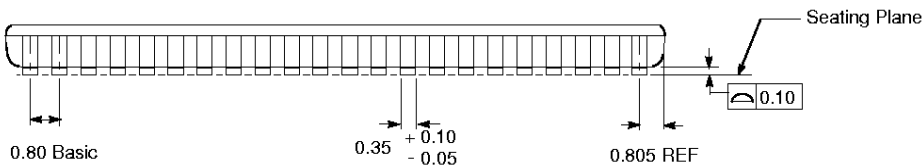
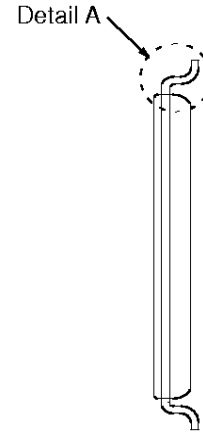
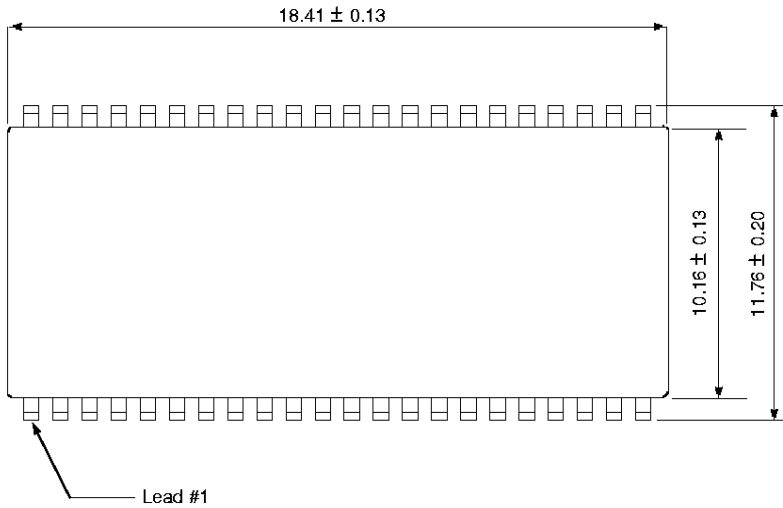

PACKAGE DIMENSIONS (400mil; 50 lead; Thin Small Outline Package)

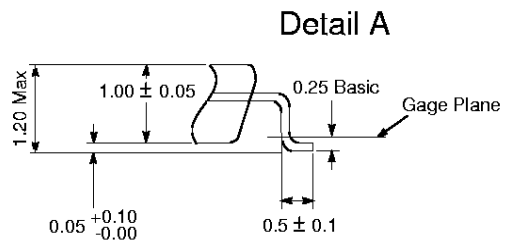
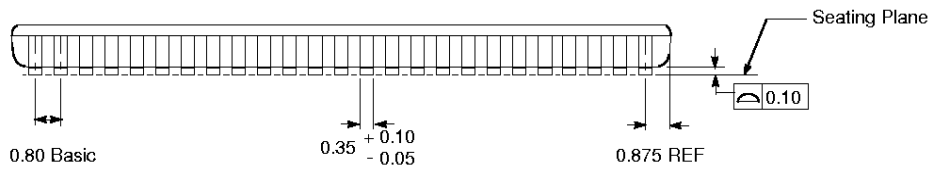
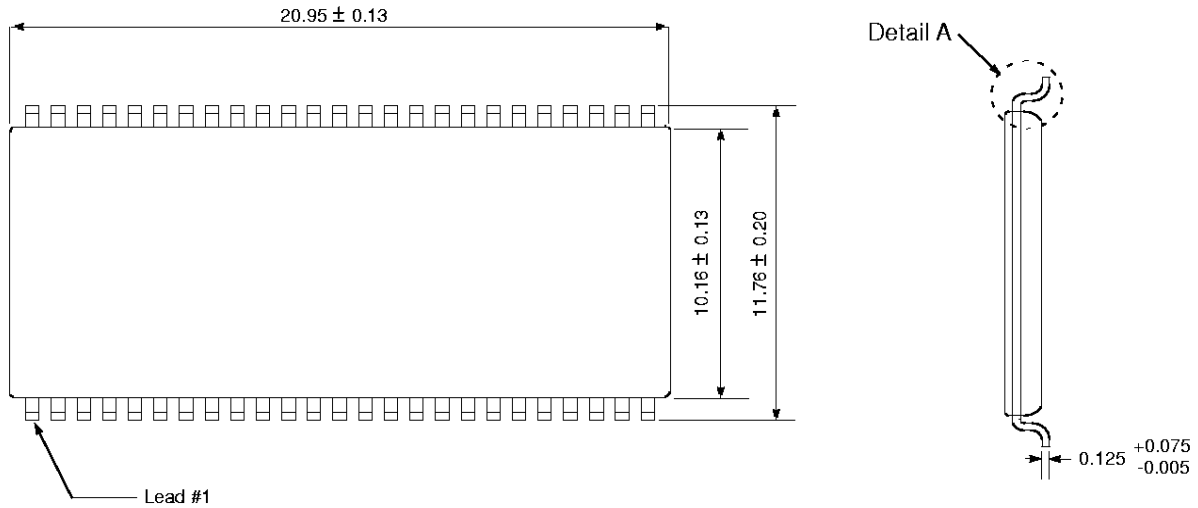



Revision Log

Revision	Contents Of Modification
9/29/95	Initial Release
01/31/96	2nd Release
page 2	Correction to pin description of VSSQ.
page 8 page 38 page 39 page 46	Change number of required Auto Refresh Cycles from <i>eight Auto Refresh Cycles</i> to ... <i>a minimum of 2 Auto Refresh Cycles</i> .
page 9	Corrections to Burst Length Table: Change Entry 000 from Reserve to 1. Change Entry 001 from Reserve to 2.
page 9	Correction to Operation Mode Table: Change "BS/A10/A9/A8/A7" to "M11/M10/M9/M8/M7".
page 19	Further clarification regarding Auto-Precharge cycles when the device is programmed for burst length of full page.
page 25	Correction to description of Automatic Refresh Command (change <i>increments</i> to <i>decrements</i>).
page 26	Correction to description of Power Down mode (change statement to say... "all receiver circuits <i>except CLK and CKE</i> are gated off.").
page 27	Correct error in diagram: Clock Suspend During a Read Cycle.
page 27	Correct error in diagram: Clock Suspend During a Write Cycle.
page 28	Delete <i>Note 2</i> in the Command Truth Table.
page 29	Change <i>Note 2</i> in the Clock Enable Truth Table from ... <i>asynchronously</i> to ... <i>synchronously</i> .
page 34	Correction to Recommended DC Operating Conditions Table: Change V _{il} (min) from -0.5V to -0.3V.
page 34	Correction to Capacitance Table: Change C _O from (DQ0-DQ3 to DQ0-DQ15).
page 35	Correction to Standby and Refresh Currents Table: Auto Refresh Current.
page 36	Correction to Operating Currents Table: Burst Length = 1.
page 36	Correction to Operating Currents Table: Burst Length = 2.
page 36	Correction to Operating Currents Table: Burst Length = 4.
page 36	Correction to Operating Currents Table: Burst Length = 8.
page 36	Correction to Operating Currents Table: Burst Length = Full Page.
page 37	Correction to Operating Currents Table: Burst Length = 1-N Rule.
page 39	Modification to Read Cycle Table: Separate tHZ into 3 parameters (tHZ1, tHZ2,tHZ3).
page 38	Correction to AC Characteristic timing diagram.
page 38	Addition to Clock and Clock Enable Parameter Table: CKE setup time for power down mode (tCESP).
page 39	Change definition of Self Refresh Exit time. Add Note 3 to Refresh Cycle Table.
page 39 page 40	Correction to Minimum Bank Cycle Time (tRC).
page 39 page 40	Correction to Minimum Bank Activate Time (tRAS).
page 41	Correction to Timing Diagram Cross Reference Table. The page numbers for the individual timing diagrams were improperly referenced.
page 55	Correction to Timing Diagram: Self Refresh (Entry and Exit).
page 90	Correction to Timing Diagram: Burst Read and Single Write Operation (Burst ends normally after Ay3).



16Mb Synchronous DRAM

Revision Log

	page 83	Correction and Clarification to Timing Diagram: Full Page Read Cycle (1 of 3).
	page 84	Correction and Clarification to Timing Diagram: Full Page Read Cycle (2 of 3).
	page 85	Correction and Clarification to Timing Diagram: Full Page Read Cycle (3 of 3).
	page 86	Correction and Clarification to Timing Diagram: Full Page Write Cycle (1 of 3).
	page 87	Correction and Clarification to Timing Diagram: Full Page Write Cycle (2 of 3).
	page 88	Correction and Clarification to Timing Diagram: Full Page Write Cycle (3 of 3).
	page 99	Correction to plastic body width and length dimensions.
	page 100	Correction to plastic body width and length dimensions.
05/01/96	page 4	Correction to part numbers in Ordering Information
10/02/96	3rd Release	
	page 1 page 4 page 35 page 36 page 38 page 39 page 40	Deletion of -11 and -13 sorts.
	page 1	Correction to package description: Should be 44 pin package (not 40 pin).
	page 1	Modification to Performance Features: Clock Access Time.
	page 20	Correction to Timing Diagram: Burst Write with Auto-Precharge.
	page 22	Description of Precharge Termination added
	page 28	Correction to Command Truth Table: Power Down Mode Entry/Exit.
	page 28	Addition of Note 7 to Command Truth Table.
	page 34	Addition of DC Output Load Circuit.
	page 35	Modification to Output Characteristics Table: Footnote added to Voh and Vol parameters.
	page 35	Correction to Standby and Refresh Currents Table: I _{CC1N} , I _{CC1NS} , I _{CC2N} , I _{CC2NS} .
	page 38	Modification to -10 and -12 timings in the AC Characteristics Tables.
	page 38	Parameter name changes (t _{CH} to t _{CKH} , t _{CL} to t _{CKL} , t _{CKS} to t _{CES} , t _{CKH} to t _{CEH} , t _{CKSP} to t _{CESP}).
	page 38	Modification to AC Characteristics Table: Clock Enable setup time changes from 3.5 to 3 ns.
	page 39	Addition of t _{LZmin} and t _{HZmin} parameters and change to t _{HZmax} parameters.
	page 40	Modification to Write Cycle Table: t _{DPL} and t _{DAL} no longer shown for 3 different CAS latency cases.
	page 53	Change to Timing Diagram: Power Down Mode and Clock Suspension.
	page 60	Change to Timing Diagram: Random Column Write (Page within same Bank) (2 of 3).
	page 61	Correction to Timing Diagram: Random Column Write (Page within same Bank) (3 of 3).
	page 63	Correction to Timing Diagram: Random Row Read (Interleaving Banks) (2 of 3).
	page 64	Correction to Timing Diagram: Random Row Read (Interleaving Banks) (3 of 3).
	page 83	Correction and Clarification to Timing Diagram: Full Page Read Cycle (1 of 3).
	page 85	Correction and Clarification to Timing Diagram: Full Page Read Cycle (3 of 3).
	page 86	Correction and Clarification to Timing Diagram: Full Page Write Cycle (1 of 3).



Revision Log

1/7/97	page 41	Changed tRP, tRCD from 36 to 30 in the common parameters table.
--------	---------	---



© International Business Machines Corp.1997

Printed in the United States of America
All rights reserved

IBM and the IBM logo are registered trademarks of the IBM Corporation.

This document may contain preliminary information and is subject to change by IBM without notice. IBM assumes no responsibility or liability for any use of the information contained herein. Nothing in this document shall operate as an express or implied license or indemnity under the intellectual property rights of IBM or third parties. The products described in this document are not intended for use in implantation or other direct life support applications where malfunction may result in direct physical harm or injury to persons. **NO WARRANTIES OF ANY KIND, INCLUDING, BUT NOT LIMITED TO, THE IMPLIED WARRANTIES OF MERCHANTABILITY OR FITNESS FOR A PARTICULAR PURPOSE, ARE OFFERED IN THIS DOCUMENT.**

For more information contact your IBM Microelectronics sales representative or visit us on **World Wide Web** at <http://www.chips.ibm.com>

IBM Microelectronics manufacturing is ISO 9000 compliant.