



AH20016

High-Speed, 500 ns Very High Accuracy Wideband Sample-and-Hold Amplifier

Performance Features

The AH20016 is the fastest precision sample-and-hold amplifier available, featuring an acquisition time of 500 ns with $\pm 0.0015\%$ nonlinearity. The AH20016 provides an optimal combination of speed and precision, as evidenced by its low aperture uncertainty of 10 ps rms, excellent linearity, low feedthrough of -100 dB at 250 kHz, and its 1 MHz full power bandwidth. In fact, this sample-and-hold amplifier was designed for Analogic's AM40016 A/D converter, which features 16-bit performance with a 500 kHz sampling rate. Accepting a bipolar ± 10 V input signal, the AH20016 has a high input impedance (100 M Ω), low input capacitance (10 pF), and low noise (70 μ V rms). The superior performance of the AH20016 makes it an ideal choice for multiplexed, high-speed, high resolution applications such as professional audio digitizing, automatic test equipment, and industrial data acquisition and control systems.

In a multiplexed data acquisition application, the AH20016 provides not only high speed and high resolution but also the required high input impedance. Voltage divider error, caused by the multiplexer's ON resistance in series with the input impedance, is negligible with the AH20016 because of its 100 M Ω input impedance. Thus, the AH20016 sample-and-hold is an excellent choice for interfacing to CMOS or FET analog multiplexers.

The AH20016 features a low droop rate of 2 μ V/ μ s, making it particularly well suited for 16-bit A/D converters. In the hold mode the AH20016 will hold an input signal to $\pm 0.0003\%$ of full scale for 15 μ s!

Features

- Fast Acquisition (500 ns)
- Low Aperture Uncertainty (10 ps rms)
- 1 MHz Full Power Bandwidth
- Low Feedthrough (-100 dB at 250 kHz)
- Excellent Linearity ($\pm 0.0015\%$)
- High Input Impedance (100 M Ω)
- Low Input Capacitance (10 pF)
- Low Droop Rate (2 μ V/ μ s)
- Ease of Use
- Low Power
- 24-Pin Hybrid Package
- Standard Pinout

Applications

- Wideband Data Acquisition Systems
- Professional Audio
- Telecommunications
- Automatic Test Equipment
- Industrial Process Control
- Nuclear Research

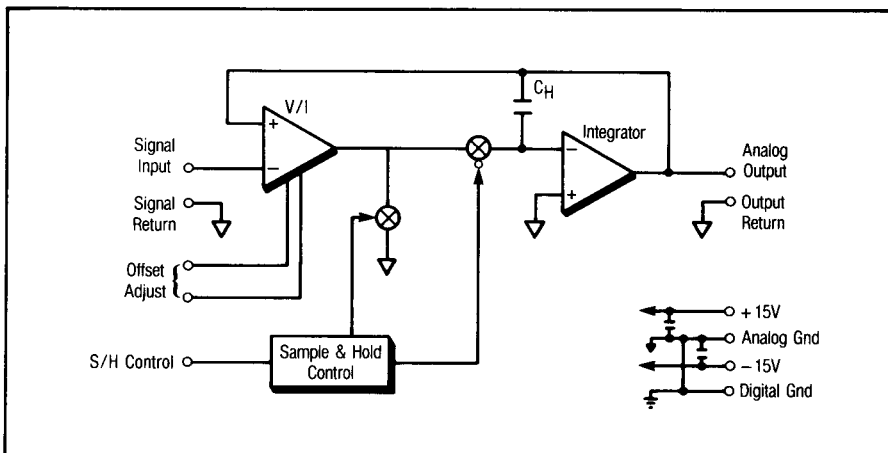

Figure 1. AH20016 Simplified Block Diagram.

AH20016 SPECIFICATIONS ⁽¹⁾

ANALOG INPUT

Input Range	± 10V Min. ⁽²⁾
Input Bias Current	10 nA Max.
Input Capacitance	10 pF
Input Impedance	100 MΩ

CONTROL INPUT

Logic "0" (Sample)	-0.5V Min., 1.6V Max.
Logic "1" (Hold)	3.8V Min., +5.5V Max.
Required Rise Time	5 ns Max. for Min. Aperture Time

DYNAMIC CHARACTERISTICS

Acquisition Time	500 ns Typ., 550 ns Max. to 0.0015% of 20V Input Step, 400 ns Max. to ±0.0015% of 10V Input Step
Sample-to-Hold Transient Settling Time	150 ns Max. to ±0.005%
Output Slew Rate	65V/μs min., 75V/μs Typ.
Pedestal	500 μV Typ., 1 mV Max.
Aperture Delay	15 ns
Aperture Uncertainty	10 ps (rms)
Full Power Bandwidth	1 MHz
Small Signal Bandwidth	10 MHz
Droop Rate	2 μV/μs Typ., 5 μV/μs Max.
Feedthrough	
20 Vp-p at 250 kHz	- 100 dB
20 Vp-p at 500 kHz	- 98 dB

TRANSFER CHARACTERISTICS

Gain	+1 ±0.005% Typ., ±0.01% Max.
Non-Linearity	±0.0015% Typ., ±0.003% Max.
Offset Error	±5 mV (Adjustable to zero)
Noise (Hold Mode) DC to 1 MHz	70 μV (rms) Max.
Noise (Sample Mode) DC to 1 MHz	20 μV (rms) Max.
Output Voltage	±10V Min.
Maximum Load	1kΩ Min. 50 pF Max. (including cables)
Dielectric Absorption	±0.005% of Voltage Change (5 μs Sample, 5 μs Hold)

STABILITY (0° to 70°C)

Offset Drift	±100 μV/°C Max.
Droop Rate	Doubles every 10°C
Warm-Up Time	5 minutes

POWER REQUIREMENTS⁽³⁾

±15V Supplies	14.5V Min., 15.5V Max.
+15V Current Drain	33 mA Typ., 40 mA Max.
-15V Current Drain	33 mA Typ., 40 mA Max.
Power Consumption	990 mW Typ., 1.24W Max.
Power Supply Rejection Ratio	±15 ppm FSR/% Max.

ENVIRONMENTAL & MECHANICAL

Temperature Range	
Rated Performance	0° to 70°C
Storage	-25°C to 85°C
Relative Humidity	0 to 85% non-condensing up to 40°C
Dimensions	1.3'' x 0.8'' x 0.2'' (24-pin double DIP)

Notes:

1. All specifications guaranteed at 25°C and ±15V supplies unless otherwise noted.
2. Absolute maximum input range without damage is ±15V.
3. It is possible to use power supplies from ±12V to ±18V. Consult factory.

System Considerations

Sample-and-hold amplifiers are often used to sample many channels at the same instant in time, such as in seismic data acquisition, and to reduce the time uncertainty (and resultant amplitude error) when digitizing fast time-varying signals. Practical systems have inherent finite sampling apertures; however, the AH20016 minimizes this time to an aperture uncertainty of 10 ps. Figure 2 illustrates the typical timing of the AH20016⁽¹⁾. If a system uses an A/D converter without a sample-and-hold, the time uncertainty is the conversion time of the A/D converter, which is several orders of magnitude longer than the S/H's aperture uncertainty.

A sample-and-hold is required for a particular A/D conversion application if the input signal is changing fast enough so that the input to the A/D converter changes by more than one LSB during the conversion time. For a sinusoidal signal, the calculation⁽²⁾ is straightforward:

$$F_{Max} = \frac{LSB}{(Full\ Scale\ Range) (\pi) (A/D\ Conversion\ Time)}$$

F_{Max} represents the maximum allowable input frequency.

For example, Analogic's ADAM-826-2 16-bit A/D converter has a conversion time of 2.0 μ s and a 20V full scale range. Therefore, the maximum signal input frequency without a sample-and-hold is:

$$F_{Max} = \frac{20V / (2^{16} - 1)}{(20V) (\pi) (2 \mu s)} = 2.4\ Hz$$

Based on this analysis it is clear that most 16-bit applications would require a sample-and-hold.

By using the AH20016 sample-and-hold the maximum signal frequency increases dramatically. In applications that use a sample-and-hold, the S/H aperture uncertainty replaces the A/D conversion time in the previous equation:

$$F_{Max} = \frac{20V / (2^{16} - 1)}{(20V) (\pi) (10\ ps)} = 485.7\ kHz$$

Bypass Capacitor

Two 6.8 μ F tantalum bypass capacitors should be installed close to the AH20016, between +15V and analog ground and between -15V and analog ground.

Adjustments

The AH20016 allows the input offset error to be externally nulled to zero by connecting a 5 k Ω potentiometer across pins 17 and 18 as shown in Figure 5. To adjust the offset voltage, place the AH20016 in the sample mode, short pins 13 and 15, and set the offset potentiometer such that the output of the S/H is 0V.

The AH20016 does not include a pedestal adjustment. The pedestal is factory adjusted to <1 mV.

The gain of the AH20016 is typically within $\pm 0.0015\%$ of the nominal $\pm 10V$ output. This small gain error of the sample-and-hold can be compensated via the gain adjustment potentiometer on the A/D converter following the AH20016.

Notes:

1. For a discussion of how to determine the overall throughput rate for the S/H and A/D converter, refer to page 156 of the *Analogic Data Conversion Systems Digest*.
2. The derivation of this formula is shown on p.154 of the *Analogic Data Conversion Systems Digest*.

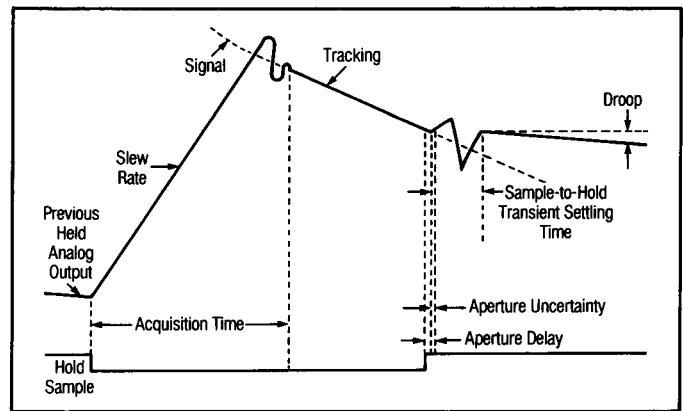

Figure 2. AH20016 Timing Diagram.

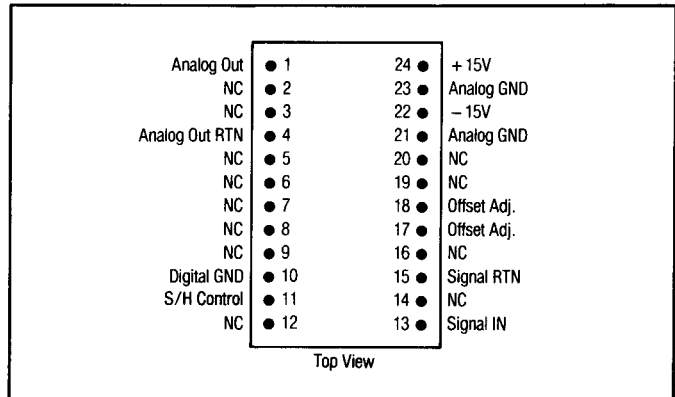

Figure 3. AH20016 Pinout.

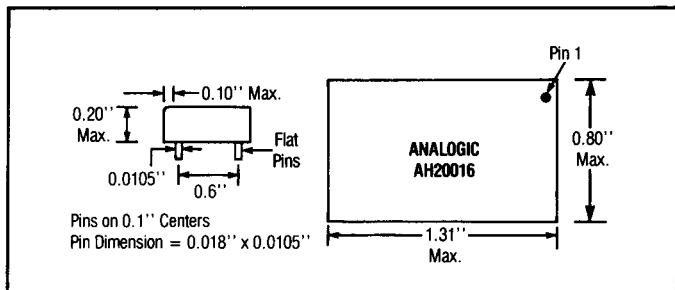

Figure 4. AH20016 Mechanical Outline.

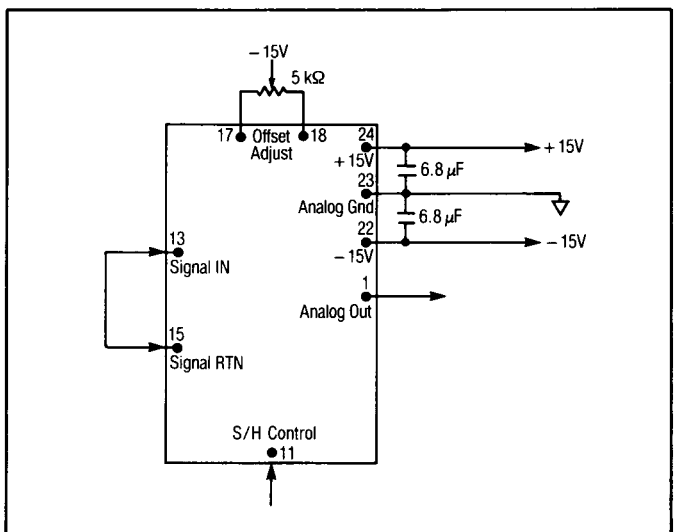

Figure 5. Offset Adjustment.

Principles of Operation

As shown in Figure 1, the AH20016 Sample-and-Hold Amplifier uses a summing node technique, which is characterized by the inclusion of the switches within a high gain closed feedback loop. The critical feature of this technique is that it compensates for many of the nonlinearities of the switches and amplifiers.

Several critical components in the design account for the high speed and superb linearity of the AH20016. The purpose of the voltage-to-current converter is to convert the difference between the input and output voltage to a current at the input to the integrating op amp in the output stage. The storage capacitor exhibits low dielectric absorption, thus allowing it to charge and discharge quickly for high throughput rates. Another advantage of low dielectric absorption is the excellent linearity of the AH20016. The output amplifier of this sample-and-hold serves as an integrator with low offset error and fast settling time.

The switching sequence is as follows. In the sample mode, switch S1 is closed, and switch S2 is opened, as the input signal is stored by the integrator. In the hold mode, switch S2 is closed, and S1 is opened. During the hold mode, switch S1 exhibits low leakage and S2 has low feedthrough, thus reducing the switching effects on the output signal. These design features make the AH20016 one of the fastest precision sample-and-hold amplifiers available.

Typical Application

A typical application of the AH20016 is shown in Figure 6, in which eight input channels are sampled by AH20016's and multiplexed to Analogic's ADAM-826-2 16-bit A/D converter. This circuit provides simultaneous sampling, a design requirement in conversion systems in which the phase relationship between different signals is an important parameter. For example, in seismic applications, it is crucial to sample several signals at the same instant in time. The low aperture uncertainty of the AH20016 allows that instant of time to be known very accurately.

After the hold command is issued, the multiplexer presents the signal levels to the ADAM-826-2 A/D converter as directed by the microprocessor and the control logic. With its speed, linearity, and low feedthrough, the AH20016 is an excellent sample-and-hold for high speed, high resolution, multiplexed data acquisition systems.

Note that all grounds are connected internally in the AH20016.

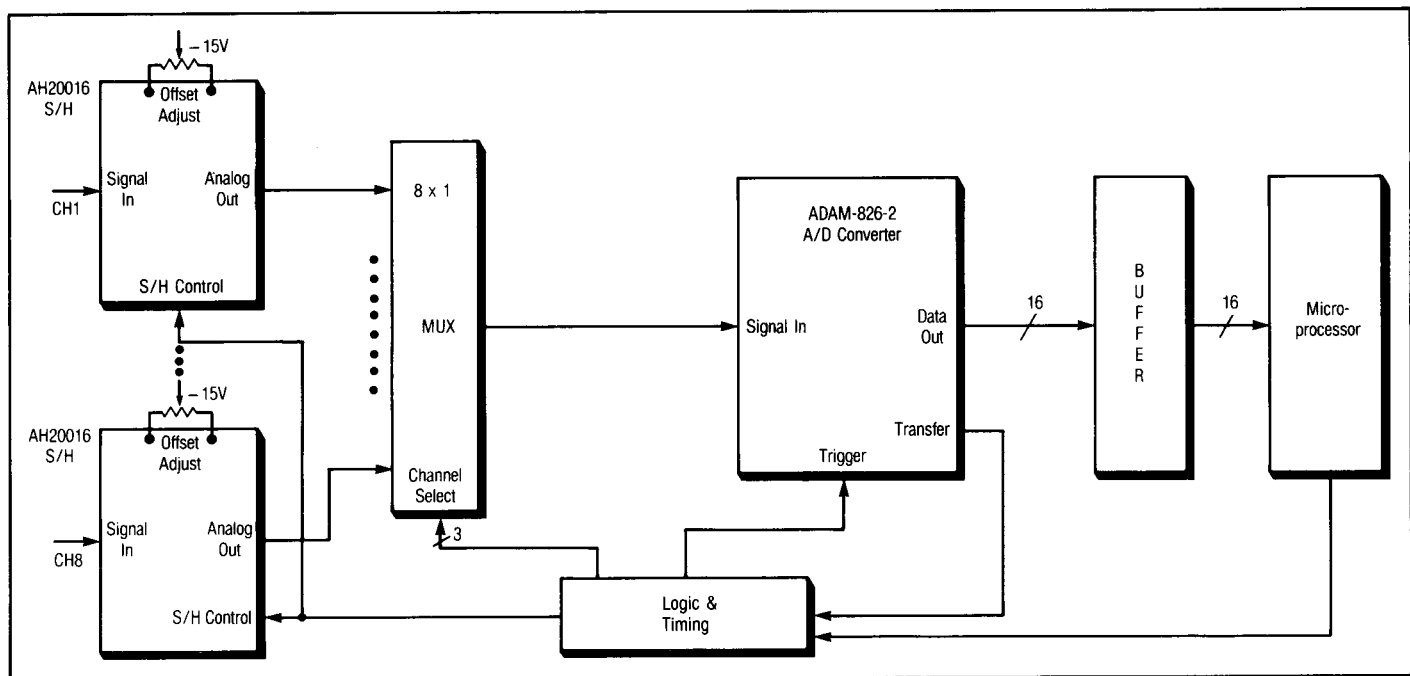

Figure 6. Typical Application for AH20016.

Ordering Guide

High Speed S/H Amplifier 24 Pin DIP
 Order # AH20016

ANALOGIC

DATA CONVERSION PRODUCTS GROUP

Analogic Corporation • 360 Audubon Road • Wakefield, MA 01880 • Tel: (508) 977-3000
 Easylink 466069 + • Answerback ANALOGIC WKFL • Fax# 617-245-1274

Analogic GmbH • Siemensstrasse 13 • 6200 Wiesbaden-Nordenstadt • W. Germany
 Tel: 49-6122-70060 • Teletex: 841-6122969 ANALO WI • Fax# 49-612215262

Analogic Ltd • Ascot House • Doncastle Road • Bracknell • Berkshire • England RG12 4PE
 Tel: 44-3-44-860111 • Telex: 851-847145 ANALOG G • Fax: 44-3-44-860478

010700 X - X