

National Semiconductor is now part of
Texas Instruments.

Search <http://www.ti.com/> for the latest technical
information and details on our current products and services.

DS3680

Quad Negative Voltage Relay Driver

General Description

The DS3680 is a quad high voltage negative relay driver designed to operate over wide ranges of supply voltage, common-mode voltage, and ambient temperature, with 50 mA sink capability. These drivers are intended for switching the ground end of loads which are directly connected to the negative supply, such as in telephone relay systems.

Since there may be considerable noise and IR drop between logic ground and negative supply ground in many applications, these drivers are designed to operate with a high common-mode range ($\pm 20V$ referenced to negative supply ground). Each driver has a common-mode range separate from the other drivers in the package, which permits input signals from more than one element of the system.

With low differential input current requirements (typically 100 μA), these drivers are compatible with TTL, LS and CMOS logic. Differential inputs permit either inverting or non-inverting operation.

The driver outputs incorporate transient suppression clamp networks, which eliminate the need for external networks when used in applications of switching inductive loads. A fail-safe feature is incorporated to ensure that, if the + IN input or both inputs are open, the driver will be OFF.

Features

- -10V to -60V operation
- Quad 50 mA sink capability
- TTL/LS/CMOS or voltage comparator input
- High input common-mode voltage range
- Very low input current
- Fail-safe disconnect feature
- Built-in output clamp diode

Connection Diagram

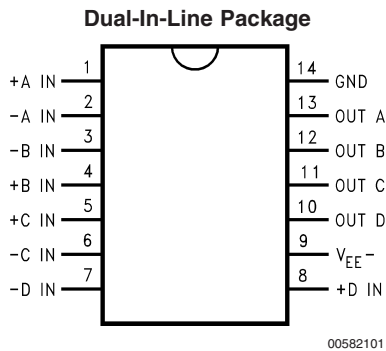

Top View
 Order Number DS3680J, DS3680M or DS3680N
 See NS Package Number J14A, M14A, N14A

Logic Diagram

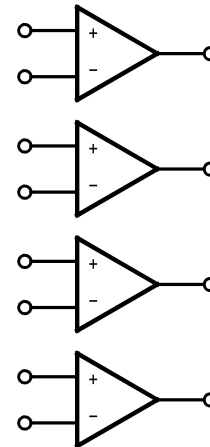

Truth Table

Differential Inputs	Outputs
$V_{ID} \geq 2V$	On
$V_{ID} \leq 0.8V$	Off
Open	Off

Absolute Maximum Ratings (Note 1)

If Military/Aerospace specified devices are required, please contact the National Semiconductor Sales Office/Distributors for availability and specifications.

Supply Voltage (GND to V_{EE^-} , and Any Pin)	-70V
Positive Input Voltage (Input to GND)	20V
Negative Input Voltage (Input to V_{EE^-})	-5V
Differential Voltage (+ IN to - IN)	$\pm 20V$
Inductive Load	$L_L \leq 5h$ $I_L \leq 50 \text{ mA}$
Output Current	-100 mA
Storage Temperature	-65°C to +150°C
Maximum Power Dissipation (Note 2) at 25°C	
Cavity Package	1433 mW
Molded Dip Package	1398 mW

SO Package

1002 mW

Lead Temperature (Soldering, 4 seconds)

260°C

Recommended Operating Conditions

	Min	Max	Units
Supply Voltage (GND to V_{EE^-})	-10	-60	V
Input Voltage (Input to GND)	-20	20	V
Logic ON Voltage (+IN)			
Referenced to -IN	2	20	V
Logic OFF Voltage (+IN)			
Referenced to -IN	-20	0.8	V
Temperature Range	-25	+85	°C

Electrical Characteristics (Notes 3, 4)

Symbol	Parameter	Conditions	Min	Typ	Max	Units
V_{IH}	Logic "1" Input Voltage		2.0	1.3		V
V_{IL}	Logic "0" Input Voltage			1.3	0.8	V
I_{INH}	Logic "1" Input Current	$V_{IN} = 2V$ $V_{IN} = 7V$		40 375	100 1000	μA
I_{INL}	Logic "0" Input Current	$V_{IN} = 0.4V$ $V_{IN} = -7V$		-0.01 -1	-5 -100	μA
V_{OL}	Output ON Voltage	$I_{OL} = 50 \text{ mA}$		-1.6	-2.1	V
I_{OFF}	Output Leakage	$V_{OUT} = V_{EE^-}$		-2	-100	μA
I_{FS}	Fail-Safe Output Leakage	$V_{OUT} = V_{EE^-}$ (Inputs Open)		-2	-100	μA
I_{LC}	Output Clamp Leakage Current	$V_{OUT} = GND$		2	100	μA
V_C	Output Clamp Voltage	$I_{CLAMP} = -50 \text{ mA}$ Referenced to V_{EE^-}		-2	-1.2	V
V_P	Positive Output Clamp Voltage	$I_{CLAMP} = 50 \text{ mA}$ Referenced to GND		0.9	1.2	V
$I_{EE(ON)}$	ON Supply Current	All Drivers ON		-2	-4.4	mA
$I_{EE(OFF)}$	OFF Supply Current	All Drivers OFF		-1	-100	μA
$t_{PD(ON)}$	Propagation Delay to Driver ON	$L = 1h, R_L = 1k,$ $V_{IN} = 3V \text{ Pulse}$		1	10	μs
$t_{PD(OFF)}$	Propagation Delay to Driver OF	$L = 1h, R_L = 1k,$ $V_{IN} = 3V \text{ Pulse}$		1	10	μs

Note 1: "Absolute Maximum Ratings" are those values beyond which the safety of the device cannot be guaranteed. Except for "Operating Temperature Range", they are not meant to imply that the device should be operated at these limits. The table of "Electrical Characteristics" provides conditions for actual device operation.

Note 2: Derate cavity package 9.6 mW/°C above 25°C, derate molded dip package 11.2 mW/°C above 25°C, derate SO package 8.02 mW/°C above 25°C.

Note 3: Unless otherwise specified, the min/max limits of the table of "Electrical Characteristics" apply within the range of the table of "Operating Conditions". All typical values are given for $V_{EE^-} = 52V$, and $T_A = 25^\circ C$.

Note 4: All currents into device pins shown as positive, out of the device as negative. All voltages are referenced to ground unless otherwise noted.

Schematic Diagrams

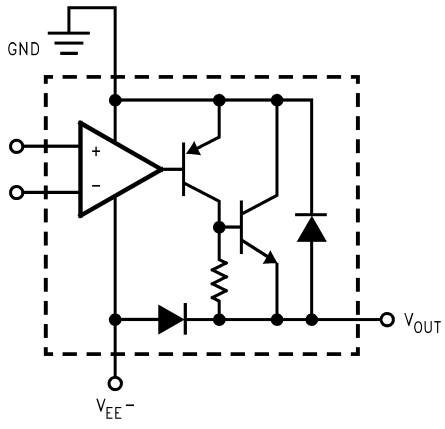

00582103

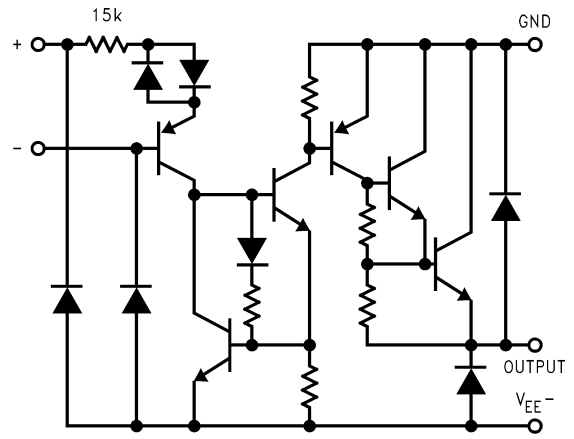

(1/4 CIRCUIT SHOWN)

00582104

Physical Dimensions inches (millimeters) unless otherwise noted

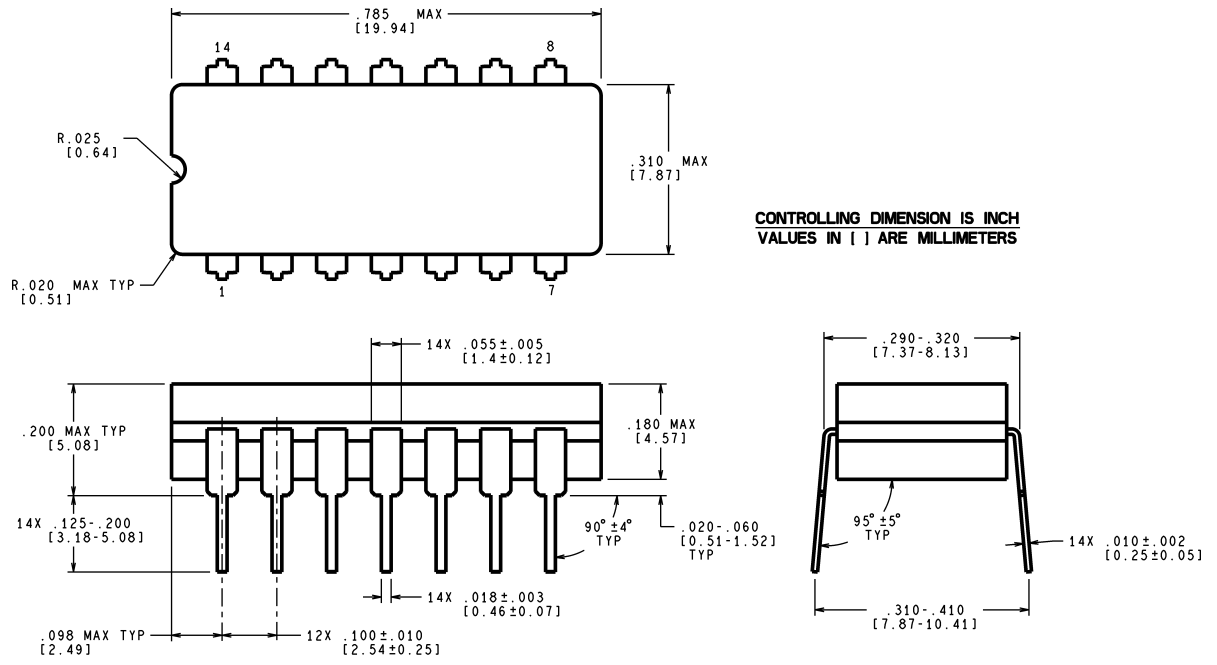

**CONTROLLING DIMENSION IS INCH
VALUES IN [] ARE MILLIMETERS**

**Ceramic Dual-In-Line Package (J)
Order Number DS3680J
NS Package Number J14A**

J14A (Rev J)

Physical Dimensions inches (millimeters) unless otherwise noted (Continued)

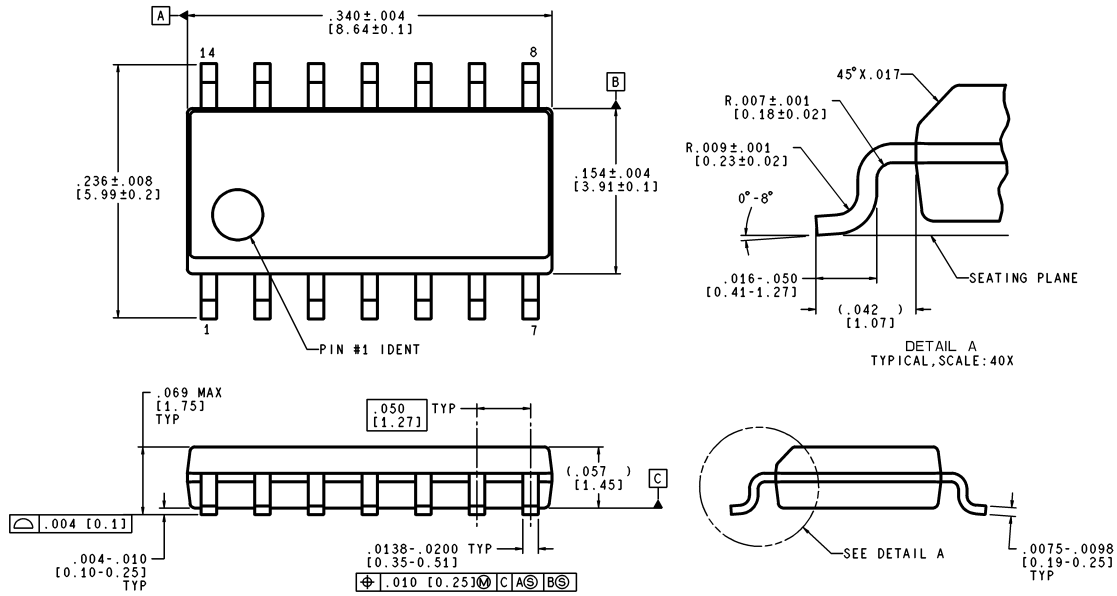

CONTROLLING DIMENSION IS INCH
VALUES IN [] ARE MILLIMETERS

M14A (Rev J)

SO Package (M)
Order Number DS3680M
NS Package Number M14A

Physical Dimensions inches (millimeters) unless otherwise noted (Continued)

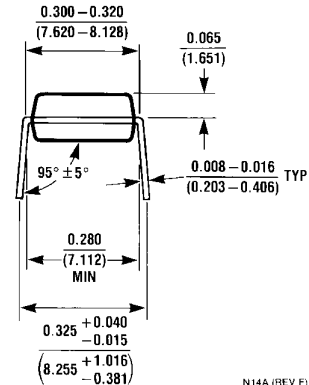
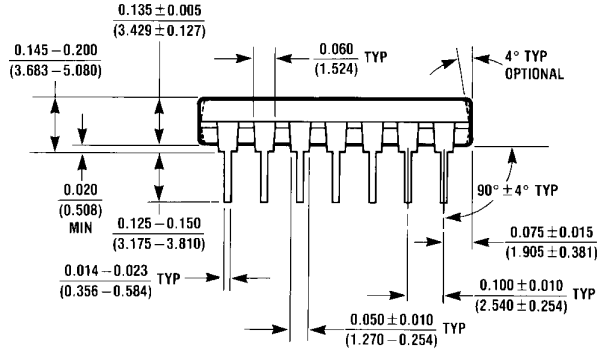
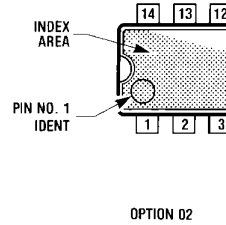
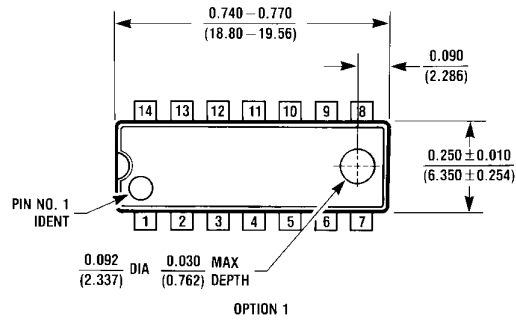

N14A (REV F)

Molded Dual-In-Line Package (N)
Order Number DS3680N
NS Package Number N14A

National does not assume any responsibility for use of any circuitry described, no circuit patent licenses are implied and National reserves the right at any time without notice to change said circuitry and specifications.

For the most current product information visit us at www.national.com.

LIFE SUPPORT POLICY

NATIONAL'S PRODUCTS ARE NOT AUTHORIZED FOR USE AS CRITICAL COMPONENTS IN LIFE SUPPORT DEVICES OR SYSTEMS WITHOUT THE EXPRESS WRITTEN APPROVAL OF THE PRESIDENT AND GENERAL COUNSEL OF NATIONAL SEMICONDUCTOR CORPORATION. As used herein:

1. Life support devices or systems are devices or systems which, (a) are intended for surgical implant into the body, or (b) support or sustain life, and whose failure to perform when properly used in accordance with instructions for use provided in the labeling, can be reasonably expected to result in a significant injury to the user.
2. A critical component is any component of a life support device or system whose failure to perform can be reasonably expected to cause the failure of the life support device or system, or to affect its safety or effectiveness.

BANNED SUBSTANCE COMPLIANCE

National Semiconductor manufactures products and uses packing materials that meet the provisions of the Customer Products Stewardship Specification (CSP-9-111C2) and the Banned Substances and Materials of Interest Specification (CSP-9-111S2) and contain no "Banned Substances" as defined in CSP-9-111S2.

 **National Semiconductor**
Americas Customer Support Center
 Email: new.feedback@nsc.com
 Tel: 1-800-272-9959

National Semiconductor
Europe Customer Support Center
 Fax: +49 (0) 180-530 85 86
 Email: europe.support@nsc.com
 Deutsch Tel: +49 (0) 69 9508 6208
 English Tel: +44 (0) 870 24 0 2171
 Français Tel: +33 (0) 1 41 91 8790

National Semiconductor
Asia Pacific Customer Support Center
 Email: ap.support@nsc.com

National Semiconductor
Japan Customer Support Center
 Fax: 81-3-5639-7507
 Email: jpn.feedback@nsc.com
 Tel: 81-3-5639-7560