



1.5A, NEGATIVE ADJUSTABLE LINEAR REGULATOR

5173

FEATURES:

- Output Current Limit
- Internal Thermal Overload Protection
- Output Current to 1.5 Amps
- Adjustable Output using two External Resistors
- Available in 3 Lead Form Options: Straight, Up and Down (TO-257)
- Electrically Isolated Package (TO-257)
- Equivalent Rad Hard Device MSK5973RH
- Contact MSK for MIL-PRF-38534 Qualification Status

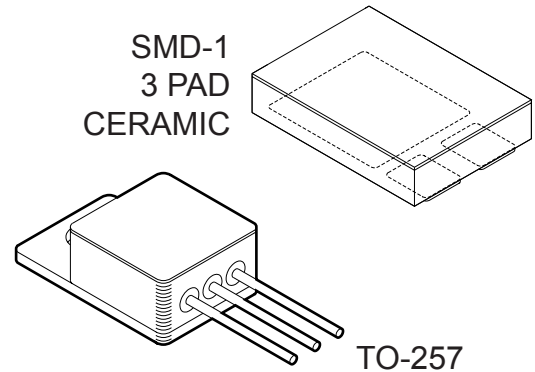

DESCRIPTION:

The MSK5173 is a 3-terminal negative adjustable regulator capable of supplying up to 1.5A of current. The output is adjustable using external resistors for a range of Vref to -27V. Excellent line and load regulation characteristics ensure accurate performance. The MSK5173 has full protection with current and thermal limiting. The MSK5173 is packaged in two space saving packages, the 3 pin power surface mount ceramic SMD-1 or the TO-257 package with 3 lead form options: straight, up and down.

EQUIVALENT SCHEMATIC

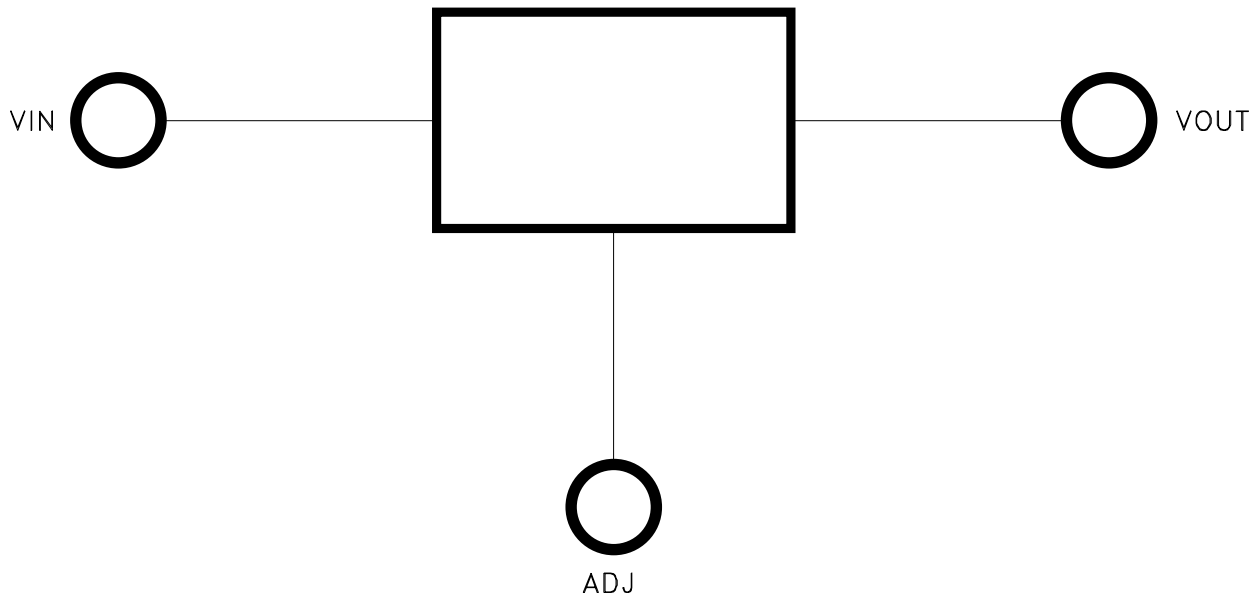

TYPICAL APPLICATIONS

- System Power Supplies
- Switching Power Supply Post Regulators
- Constant Voltage/Current Regulators
- High Efficiency Linear Regulators

PIN-OUT INFORMATION

| TO-257 | SMD-1 |
|--------|--------|
| 1 ADJ | 1 ADJ |
| 2 VIN | 2 VOUT |
| 3 VOUT | 3 VIN |

PACKAGE=ISOLATED

ABSOLUTE MAXIMUM RATINGS ^⑧

| | | |
|------------------|---|--------------------|
| V _{IN} | Input Voltage (V _{IN} -V _{OUT})..... | 30VDC |
| P _D | Power Dissipation..... | Internally Limited |
| I _{OUT} | Output Current | 1.5A |
| T _J | Junction Temperature | +150°C |

| | | |
|-----------------|--|-----------------|
| T _{ST} | Storage Temperature Range ^⑨ | -65°C to +150°C |
| T _{LD} | Lead Temperature Range (10 Seconds)..... | 300°C |
| T _C | Case Operating Temperature | |
| | MSK5173..... | -55°C to +125°C |
| | MSK5173H..... | -55°C to +125°C |

ELECTRICAL SPECIFICATIONS

| Parameter | Test Conditions | Group A Subgroup | MSK5173H | | | MSK5173 | | | Units |
|-----------------------------------|---|---------------------|----------|-------|-------|---------|-------|-------|-------|
| | | | Min. | Typ. | Max. | Min. | Typ. | Max. | |
| Reference Voltage | 3V ≤ (V _{IN} -V _{OUT}) ≤ 30V I _{OUT} =10mA | 1 | -1.30 | -1.25 | -1.20 | -1.35 | -1.25 | -1.15 | V |
| | | 2,3 | -1.30 | - | -1.20 | - | - | - | V |
| Line Regulation | 3V ≤ (V _{IN} -V _{OUT}) ≤ 30V I _{OUT} =10mA | 1 | -0.02 | 0.002 | +0.02 | -0.02 | 0.002 | +0.02 | %/V |
| | | 2,3 | -0.05 | - | +0.05 | - | - | - | %/V |
| Adjust Pin Current | 3V ≤ (V _{IN} -V _{OUT}) ≤ 30V I _{OUT} =10mA | 1 | - | 65 | 100 | - | 65 | 100 | uA |
| | | 2,3 | - | - | 100 | - | - | - | uA |
| Adjust Pin Current Change | 3V ≤ (V _{IN} -V _{OUT}) ≤ 30V I _{OUT} =10mA | 1 | -5.0 | 0.2 | +5.0 | -5.0 | 0.2 | +5.0 | uA |
| | | 2,3 | -6.0 | - | +6.0 | - | - | - | uA |
| Load Regulation | V _{IN} =-8V, V _{OUT} =-5V 10mA ≤ I _{OUT} ≤ 1.5A | 1 | -25 | - | +25 | -25 | - | +25 | mV |
| | | 2,3 | -50 | - | +50 | - | - | - | mV |
| Current Limit ^⑦ | V _{IN} =-10V V _{OUT} =-5V | 1 | 1.5 | 2.3 | - | 1.5 | 2.3 | - | A |
| | | 2,3 | 1.5 | - | - | - | - | - | A |
| Ripple Rejection ^② | V _{OUT} =-10V, F=120Hz, C _{adj} =10uF | 4 | 66 | - | - | 66 | - | - | dB |
| Minimum Load Current ^② | (V _{IN} -V _{OUT})=30V | 1 | - | - | 5 | - | - | 5 | mA |
| Thermal Resistance ^② | Junction to Case @ 125°C TO-257 Package | - | - | 5.0 | 6.7 | - | 5.0 | 6.7 | °C/W |
| Thermal Resistance ^② | Junction to Case @ 125°C SMD-1 Package | - | - | 4.4 | 6.1 | - | 4.4 | 6.1 | °C/W |

NOTES:

- ① Output is decoupled to ground using 10µF low ESR tantalum capacitors and 0.1µF ceramic.
- ② Guaranteed by design but not tested. Typical parameters are representative of actual device performance but are for reference only.
- ③ All output parameters are tested using a low duty cycle pulse to maintain T_J = T_C.
- ④ Industrial grade and devices shall be tested to subgroup 1 unless otherwise specified.
- ⑤ Military grade devices ("H" suffix) shall be 100% tested to subgroups 1,2 and 3.
- ⑥ Subgroup 1 TA=TC=+25°C
Subgroup 2 TA=TC=+125°C
Subgroup 3 TA=TC=-55°C
- ⑦ The output current limit function provides protection from transient overloads but it may exceed the maximum continuous rating. Continuous operation in current limit may damage the device.
- ⑧ Continuous operation at or above absolute maximum ratings may adversely effect the device performance and/or life cycle.
- ⑨ Internal solder reflow temperature is 180°C, do not exceed.

APPLICATION NOTES

OUTPUT VOLTAGE

The MSK5173 develops a nominal -1.25V reference voltage between the output and adjustment terminal. With a constant reference voltage drop across program resistor R1, a constant current flows through the output set resistor R2. Since the current from the adjustment terminal represents an error in the programmed output voltage, the MSK5173 was designed to minimize I_{ADJ} and make it very constant with line and load changes. To do this, all quiescent operating current is returned to the output establishing a minimum load current requirement. If there is insufficient load on the output, the output will rise. Figure 1 shows the output voltage calculations.

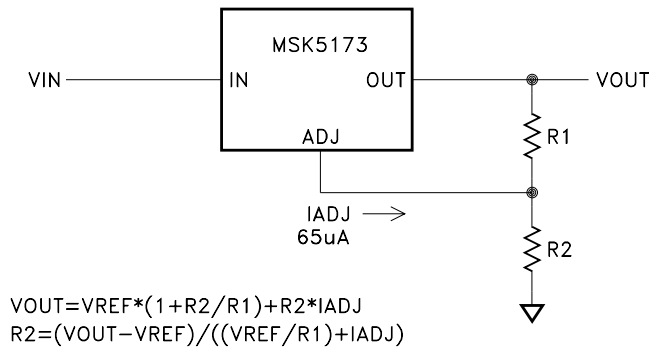

FIGURE 1

INPUT VOLTAGE

The minimum required input voltage for proper operation is V_{OUT}+ Dropout voltage. See typical performance curves for dropout performance.

EXTERNAL CAPACITORS

Input bypassing with a 1uF tantalum in parallel with a 0.1uF ceramic on the input is suitable in most applications. To maximize transient response and minimize input supply transients more input capacitance can be added. The adjustment terminal can be bypassed to ground on the MSK5173 to improve ripple rejection. This bypass capacitor prevents ripple from being amplified at higher output voltages. The impedance of the adjust pin capacitor at the ripple frequency should be less than the value of R1. For most application a 10uF bypass capacitor will provide sufficient ripple rejection at any output level. Increases over 10uF do not appreciably improve the ripple rejection at frequencies above 120Hz. Output bypassing with 10uF low ESR tantalum in parallel with a 0.1uF ceramic attached as close to the regulator's output as possible is best. This will effectively lower the regulator output impedance, increase transient response and eliminate any oscillations. Any increase of the load capacitance larger than 10uF will merely improve the loop stability and output impedance. See Figure 3 for typical application schematic.

LOAD REGULATION

The MSK5173 is capable of providing extremely good load regulation but a few precautions are needed to obtain maximum performance. The current set resistor connected between the adjustment terminal and the output terminal should be tied directly to the output pin as close to the case of the regulator as possible rather than near the load. This eliminates package pin and trace drops from appearing effectively in series with the reference and degrading regulation. For example, if the regulator is set to -5V with 0.05Ω resistance between the regulator and the current set resistor, the output will droop 225mV at 1A due to package pin and trace resistance. The amount of droop can be calculated as follows: (V_{OUT} at 5mA) - (1.250 - (0.05Ω * I_L)) * (1 + R₂/R₁). The ground of R₂ can be returned near the ground of the load to provide remote ground sensing and improve load regulation. Figure 2A shows the effect of resistance between the regulator and 240Ω set resistor.

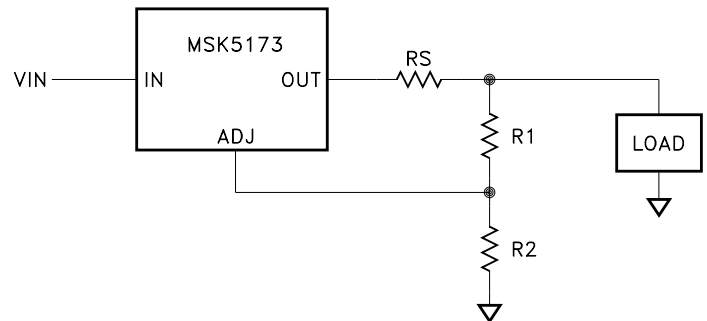

FIGURE 2A
(Degraded Regulation)

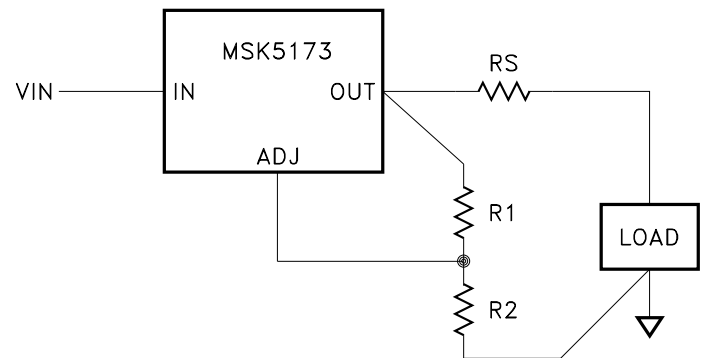
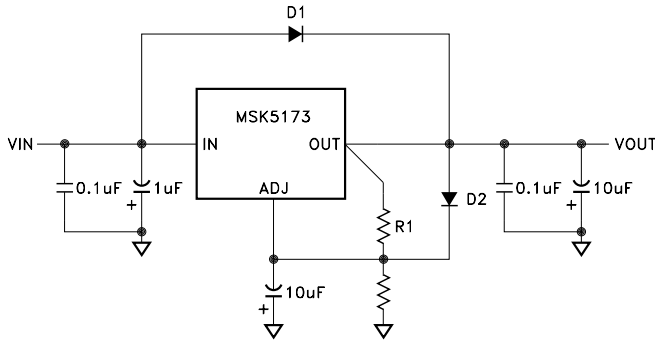

FIGURE 2B
(Best Case Regulation)

PROTECTION DIODES

When external capacitors are used with any IC regulator it is sometimes necessary to add protection diodes to prevent the capacitors from discharging through low current points into the regulator. Most 10µF capacitors have low enough internal series resistance to deliver 20A spikes when shorted. Although the surge is short, there is enough energy to stress MSK5173. When an output capacitor is connected to a regulator and the input is shorted or crowbarred, the output capacitor will discharge into the output of the regulator. The discharge current depends on the value of the capacitor, the output voltage of the regulator, and the rate of decrease of VIN. Figure 3 shows an MSK5173 with protection diodes included. D2 is only required if the adjust pin has external capacitance tied to it .



TYPICAL APPLICATION

FIGURE 3

HEAT SINKING

To determine if a heat sink is required for your application and if so, what type, refer to the thermal model and governing equation below.

Governing Equation: $T_j = P_d \times (R_{\theta jc} + R_{\theta cs} + R_{\theta sa}) + T_a$

WHERE

- T_j = Junction Temperature
- P_d = Total Power Dissipation
- R_{θjc} = Junction to Case Thermal Resistance
- R_{θcs} = Case to Heat Sink Thermal Resistance
- R_{θsa} = Heat Sink to Ambient Thermal Resistance
- T_c = Case Temperature
- T_a = Ambient Temperature
- T_s = Heat Sink Temperature

EXAMPLE:

This example demonstrates an analysis with the output set to -10V, where the output current is at 0.5 amp and the input is -15V.

Conditions for MSK5173:

V_{IN} = -15V; I_{out} = 0.5A

- 1.) Assume 45° heat spreading model.
- 2.) Find regulator power dissipation:

$$P_d = (V_{IN} - V_{OUT})(I_{out})$$

$$P_d = (15V - 10V)(0.5A)$$

$$P_d = 2.5W$$

- 3.) For conservative design, set T_j = +125°C Max.
- 4.) For this example, worst case T_a = +90°C.
- 5.) R_{θjc} = 6.7°C/W from the Electrical Specification Table.
- 6.) R_{θcs} = 0.15°C/W for most thermal greases.
- 7.) Rearrange governing equation to solve for R_{θsa}:

$$R_{\theta sa} = (T_j - T_a) / P_d - (R_{\theta jc}) - (R_{\theta cs})$$

$$= (125^\circ C - 90^\circ C) / 2.5W - 6.7^\circ C/W - 0.15^\circ C/W$$

$$= 7.2^\circ C/W$$

In this case the result is 7.2°C/W. Therefore, a heat sink with a thermal resistance of no more than 7.2°C/W must be used in this application to maintain regulator circuit junction temperature under 125°C.

TYPICAL PERFORMANCE CURVES

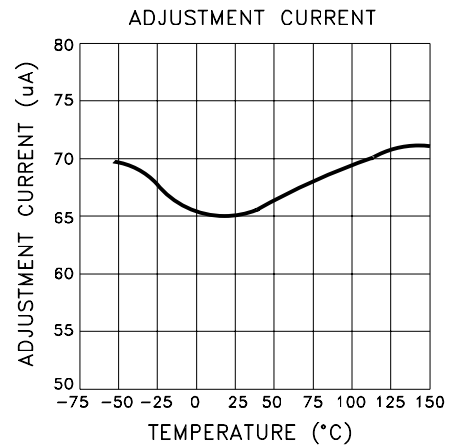
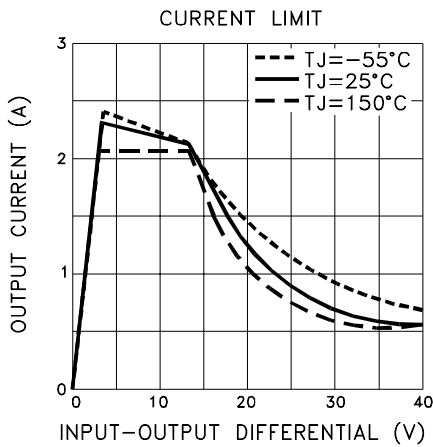
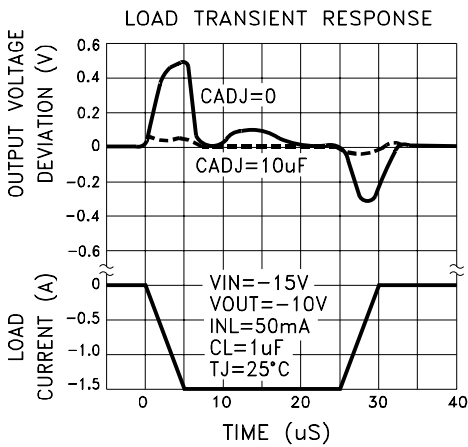
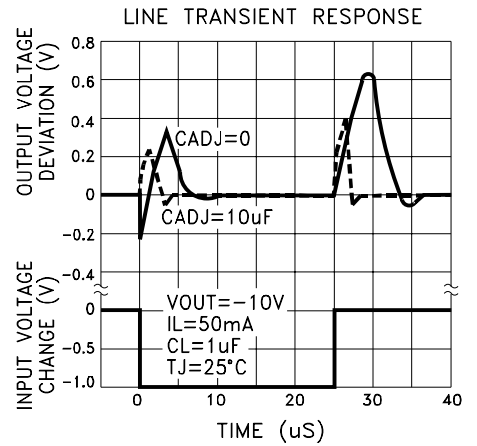
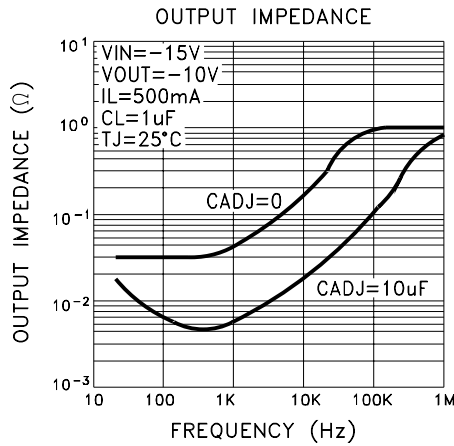
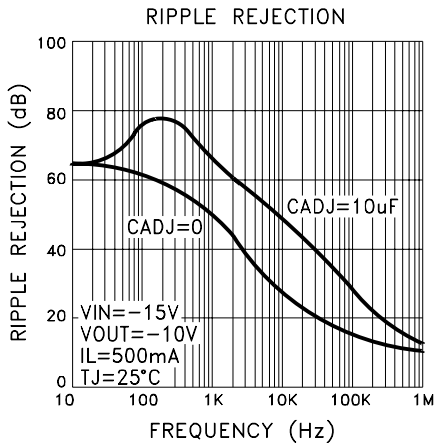
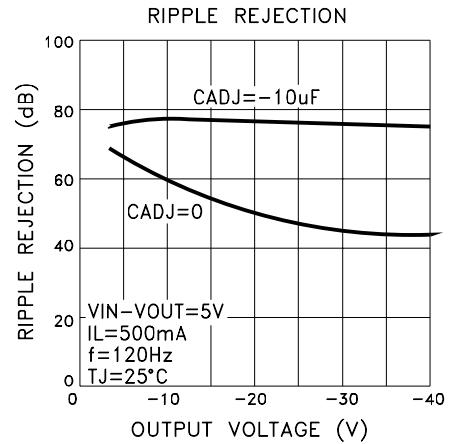
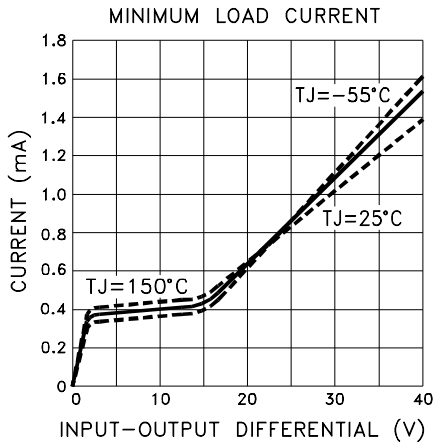
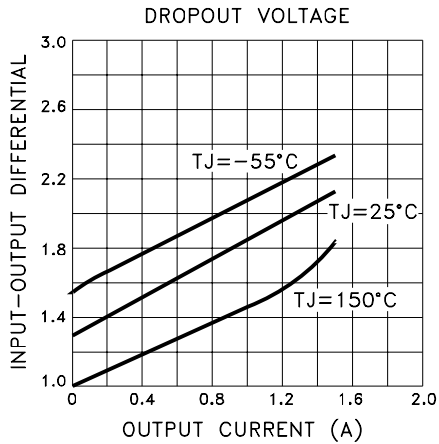

MECHANICAL SPECIFICATIONS

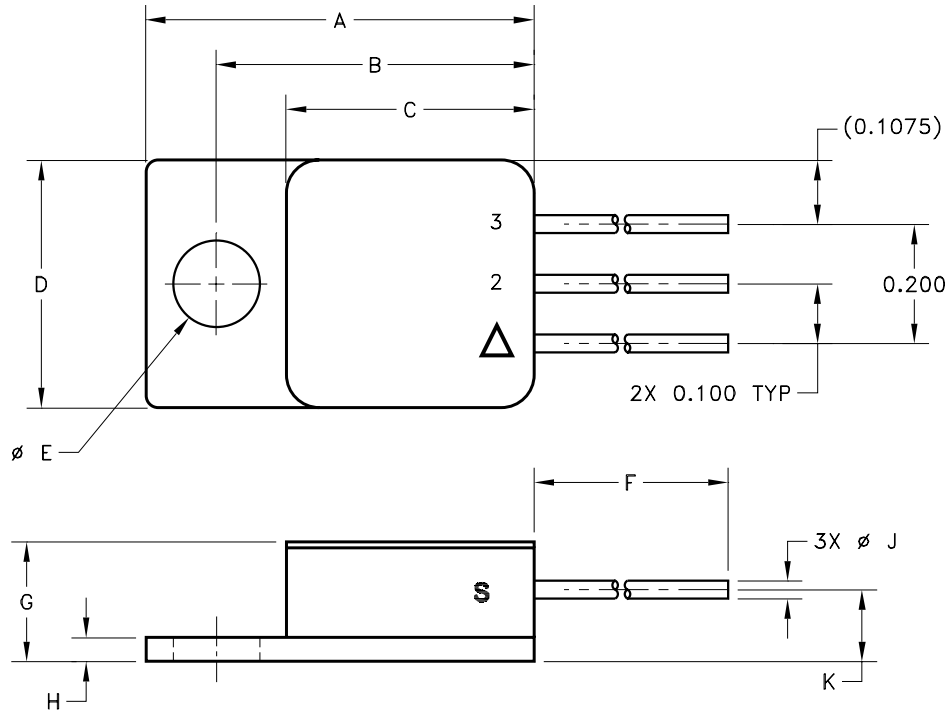

| REF | MIN | MAX | REF | MIN | MAX |
|-----|-------|-------|-----|-------|-------|
| A | 0.640 | 0.660 | H | 0.035 | 0.045 |
| B | 0.527 | 0.537 | J | 0.028 | 0.032 |
| C | 0.405 | 0.425 | K | 0.110 | 0.130 |
| D | 0.405 | 0.425 | L | 0.085 | 0.105 |
| E | 0.140 | 0.150 | M | 0.200 | |
| F | 0.400 | | N | 0.200 | |
| G | | 0.210 | | | |

ESD TRIANGLE INDICATES PIN 1
WEIGHT=3.2 GRAMS TYPICAL

ALL DIMENSIONS ARE SPECIFIED IN INCHES

ORDERING INFORMATION

MSK5173 H U

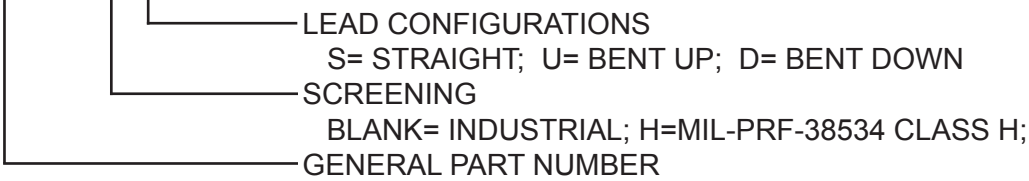

The above example is a Class H regulator with leads bent up.

MECHANICAL SPECIFICATIONS

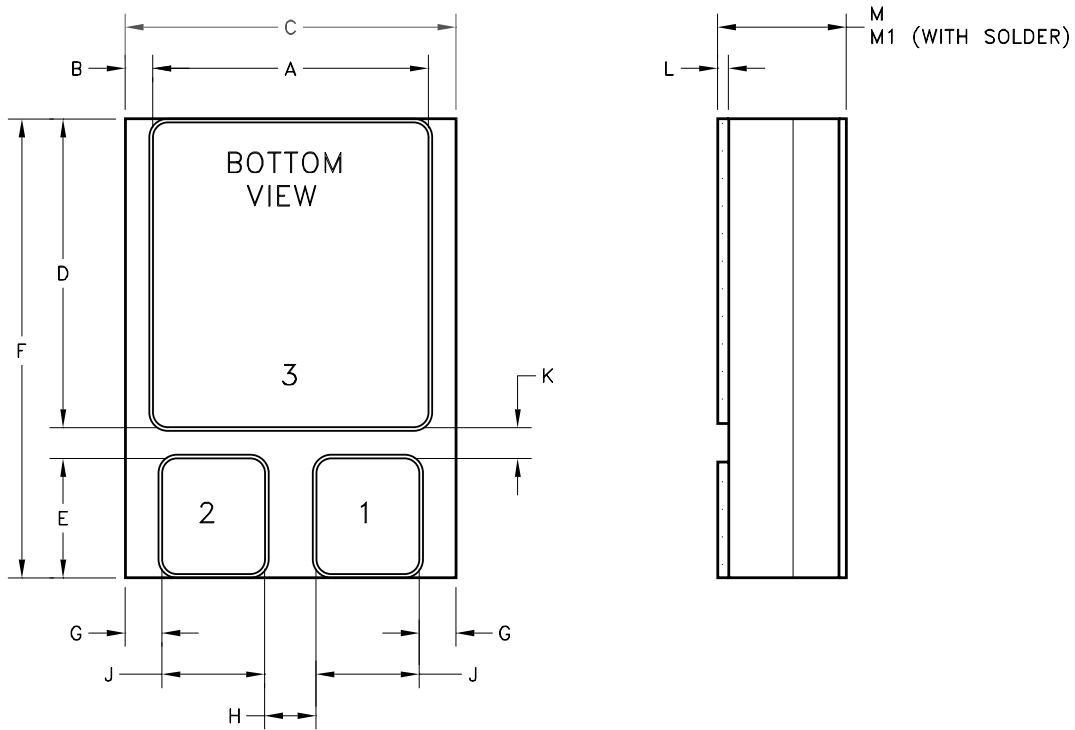

| REF | MIN | MAX | REF | MIN | MAX |
|-----|-------|-------|-----|-------|-------|
| A | 0.365 | 0.385 | H | 0.035 | — |
| B | 0.032 | 0.042 | J | 0.130 | 0.150 |
| C | 0.440 | 0.460 | K | 0.030 | — |
| D | 0.405 | 0.425 | L | 0.012 | 0.018 |
| E | 0.152 | 0.162 | M | — | 0.130 |
| F | 0.615 | 0.635 | M1 | — | 0.135 |
| G | 0.045 | 0.055 | | | |

WEIGHT=2.2 GRAMS TYPICAL

ALL DIMENSIONS ARE SPECIFIED IN INCHES

ORDERING INFORMATION

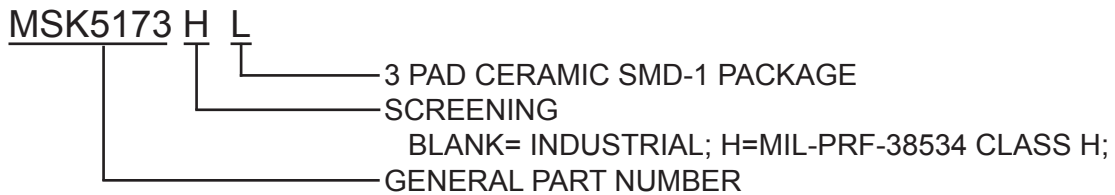

The above example is a Class H regulator in the 3 Pad Ceramic Package.

REVISION HISTORY

| REV | STATUS | DATE | DESCRIPTION |
|-----|----------|-------|--------------------------------------|
| D | Released | 01/16 | Add internal note and update format. |

MSK
www.anaren.com/msk

The information contained herein is believed to be accurate at the time of printing. MSK reserves the right to make changes to its products or specifications without notice, however, and assumes no liability for the use of its products. Please visit our website for the most recent revision of this datasheet. Contact MSK for MIL-PRF-38534 qualification status.