

The RF MOSFET Line
RF Power Field Effect Transistors
N-Channel Enhancement-Mode Lateral MOSFETs

Designed for W-CDMA base station applications with frequencies from 2110 to 2170 MHz. Suitable for TDMA, CDMA and multicarrier amplifier applications. To be used in Class AB for PCN - PCS/cellular radio and WLL applications.

- Typical 2-carrier W-CDMA Performance for $V_{DD} = 28$ Volts, $I_{DQ} = 1000$ mA, $f_1 = 2135$ MHz, $f_2 = 2145$ MHz, Channel Bandwidth = 3.84 MHz, Adjacent Channels Measured over 3.84 MHz BW @ $f_1 - 5$ MHz and $f_2 + 5$ MHz, Distortion Products Measured over a 3.84 MHz BW @ $f_1 - 10$ MHz and $f_2 + 10$ MHz, Peak/Avg. = 8.3 dB @ 0.01% Probability on CCDF.
 - Output Power — 19 Watts Avg.
 - Power Gain — 13.6 dB
 - Efficiency — 23%
 - IM3 — -37.5 dBc
 - ACPR — -41 dBc
- Internally Matched, Controlled Q, for Ease of Use
- High Gain, High Efficiency and High Linearity
- Integrated ESD Protection
- Designed for Maximum Gain and Insertion Phase Flatness
- Capable of Handling 5:1 VSWR, @ 28 Vdc, 2170 MHz, 90 Watts CW Output Power
- Excellent Thermal Stability
- Characterized with Series Equivalent Large-Signal Impedance Parameters
- Available with Low Gold Plating Thickness on Leads. L Suffix Indicates 40 μ " Nominal.
- In Tape and Reel. R3 Suffix = 250 Units per 56 mm, 13 inch Reel.

MRF21085R3
MRF21085SR3
MRF21085LSR3

2170 MHz, 90 W, 28 V
LATERAL N-CHANNEL
RF POWER MOSFETs

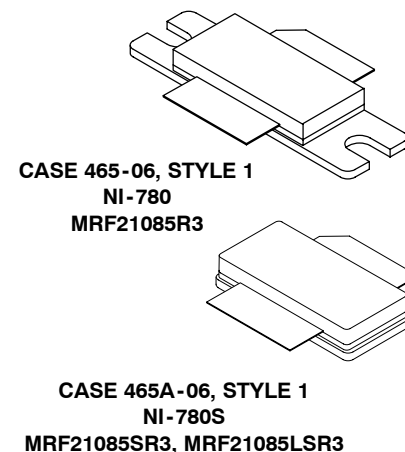

MAXIMUM RATINGS

Rating	Symbol	Value	Unit
Drain-Source Voltage	V_{DSS}	65	Vdc
Gate-Source Voltage	V_{GS}	-0.5, +15	Vdc
Total Device Dissipation @ $T_C = 25^\circ\text{C}$ Derate above 25 $^\circ\text{C}$	P_D	224 1.28	Watts W/ $^\circ\text{C}$
Storage Temperature Range	T_{stg}	- 65 to +150	$^\circ\text{C}$
Operating Junction Temperature	T_J	200	$^\circ\text{C}$

THERMAL CHARACTERISTICS

Characteristic	Symbol	Value (1)	Unit
Thermal Resistance, Junction to Case	$R_{\theta JC}$	0.78	$^\circ\text{C}/\text{W}$

ESD PROTECTION CHARACTERISTICS

Test Conditions	Class
Human Body Model	1 (Minimum)
Machine Model	M3 (Minimum)

(1) Refer to AN1955/D, *Thermal Measurement Methodology of RF Power Amplifiers*. Go to <http://www.motorola.com/semiconductors/rf>. Select Documentation/Application Notes - AN1955.

NOTE - **CAUTION** - MOS devices are susceptible to damage from electrostatic charge. Reasonable precautions in handling and packaging MOS devices should be observed.

ELECTRICAL CHARACTERISTICS ($T_C = 25^\circ\text{C}$ unless otherwise noted)

Characteristic	Symbol	Min	Typ	Max	Unit
----------------	--------	-----	-----	-----	------

OFF CHARACTERISTICS

Drain-Source Breakdown Voltage ($V_{GS} = 0 \text{ Vdc}$, $I_D = 100 \mu\text{Adc}$)	$V_{(BR)DSS}$	65	—	—	Vdc
Zero Gate Voltage Drain Current ($V_{DS} = 28 \text{ Vdc}$, $V_{GS} = 0 \text{ Vdc}$)	I_{DSS}	—	—	10	μAdc
Gate-Source Leakage Current ($V_{GS} = 5 \text{ Vdc}$, $V_{DS} = 0 \text{ Vdc}$)	I_{GSS}	—	—	1	μAdc

ON CHARACTERISTICS (DC)

Gate Threshold Voltage ($V_{DS} = 10 \text{ Vdc}$, $I_D = 200 \mu\text{Adc}$)	$V_{GS(th)}$	2	—	4	Vdc
Gate Quiescent Voltage ($V_{DS} = 28 \text{ Vdc}$, $I_D = 1000 \text{ mAdc}$)	$V_{GS(Q)}$	3	3.9	5	Vdc
Drain-Source On-Voltage ($V_{GS} = 10 \text{ Vdc}$, $I_D = 2 \text{ Adc}$)	$V_{DS(on)}$	—	0.18	0.21	Vdc
Forward Transconductance ($V_{DS} = 10 \text{ Vdc}$, $I_D = 2 \text{ Adc}$)	g_{fs}	—	6	—	S

DYNAMIC CHARACTERISTICS (1)

Reverse Transfer Capacitance ($V_{DS} = 28 \text{ Vdc}$, $V_{GS} = 0$, $f = 1.0 \text{ MHz}$)	C_{rss}	—	3.6	—	pF
--	-----------	---	-----	---	----

FUNCTIONAL TESTS (In Motorola Test Fixture, 50 ohm system) 2-carrier W-CDMA, 3.84 MHz Channel Bandwidth Carriers, ACPR and IM3 measured in 3.84 MHz Bandwidth. Peak/Avg. = 8.3 dB @ 0.01% Probability on CCDF.

Common-Source Amplifier Power Gain ($V_{DD} = 28 \text{ Vdc}$, $P_{out} = 19 \text{ W Avg.}$, $I_{DQ} = 1000 \text{ mA}$, $f_1 = 2112.5 \text{ MHz}$, $f_2 = 2122.5 \text{ MHz}$ and $f_1 = 2157.5 \text{ MHz}$, $f_2 = 2167.5 \text{ MHz}$)	G_{ps}	12	13.6	—	dB
Drain Efficiency ($V_{DD} = 28 \text{ Vdc}$, $P_{out} = 19 \text{ W Avg.}$, $I_{DQ} = 1000 \text{ mA}$, $f_1 = 2112.5 \text{ MHz}$, $f_2 = 2122.5 \text{ MHz}$ and $f_1 = 2157.5 \text{ MHz}$, $f_2 = 2167.5 \text{ MHz}$)	η	20	23	—	%
Third Order Intermodulation Distortion ($V_{DD} = 28 \text{ Vdc}$, $P_{out} = 19 \text{ W Avg.}$, $I_{DQ} = 1000 \text{ mA}$, $f_1 = 2112.5 \text{ MHz}$, $f_2 = 2122.5 \text{ MHz}$ and $f_1 = 2157.5 \text{ MHz}$, $f_2 = 2167.5 \text{ MHz}$; IM3 measured over 3.84 MHz BW at $f_1 - 10 \text{ MHz}$ and $f_2 + 10 \text{ MHz}$ referenced to carrier channel power.)	IM3	—	-37.5	-35	dBc
Adjacent Channel Power Ratio ($V_{DD} = 28 \text{ Vdc}$, $P_{out} = 19 \text{ W Avg.}$, $I_{DQ} = 1000 \text{ mA}$, $f_1 = 2112.5 \text{ MHz}$, $f_2 = 2122.5 \text{ MHz}$ and $f_1 = 2157.5 \text{ MHz}$, $f_2 = 2167.5 \text{ MHz}$; ACPR measured over 3.84 MHz at $f_1 - 5 \text{ MHz}$ and $f_2 + 5 \text{ MHz}$.)	ACPR	—	-41	-38	dBc
Input Return Loss ($V_{DD} = 28 \text{ Vdc}$, $P_{out} = 19 \text{ W Avg.}$, $I_{DQ} = 1000 \text{ mA}$, $f_1 = 2112.5 \text{ MHz}$, $f_2 = 2122.5 \text{ MHz}$ and $f_1 = 2157.5 \text{ MHz}$, $f_2 = 2167.5 \text{ MHz}$)	IRL	—	-12	-9	dB
Output Mismatch Stress ($V_{DD} = 28 \text{ Vdc}$, $P_{out} = 90 \text{ W CW}$, $I_{DQ} = 1000 \text{ mA}$, $f = 2170 \text{ MHz}$ VSWR = 5:1, All Phase Angles at Frequency of Tests)	Ψ	No Degradation In Output Power Before and After Test			

(1) Part is internally matched both on input and output.

(continued)

ELECTRICAL CHARACTERISTICS — continued ($T_C = 25^\circ\text{C}$ unless otherwise noted)

Characteristic	Symbol	Min	Typ	Max	Unit
FUNCTIONAL TESTS (In Motorola Test Fixture, 50 ohm system) (continued)					
Two-Tone Common-Source Amplifier Power Gain ($V_{DD} = 28\text{ Vdc}$, $P_{out} = 90\text{ W PEP}$, $I_{DQ} = 1000\text{ mA}$, $f_1 = 2110\text{ MHz}$, $f_2 = 2120\text{ MHz}$ and $f_1 = 2160\text{ MHz}$, $f_2 = 2170\text{ MHz}$)	G_{ps}	—	13.6	—	dB
Two-Tone Drain Efficiency ($V_{DD} = 28\text{ Vdc}$, $P_{out} = 90\text{ W PEP}$, $I_{DQ} = 1000\text{ mA}$, $f_1 = 2110\text{ MHz}$, $f_2 = 2120\text{ MHz}$ and $f_1 = 2160\text{ MHz}$, $f_2 = 2170\text{ MHz}$)	η	—	36	—	%
Two-Tone Intermodulation Distortion ($V_{DD} = 28\text{ Vdc}$, $P_{out} = 90\text{ W PEP}$, $I_{DQ} = 1000\text{ mA}$, $f_1 = 2110\text{ MHz}$, $f_2 = 2120\text{ MHz}$ and $f_1 = 2160\text{ MHz}$, $f_2 = 2170\text{ MHz}$)	IMD	—	-31	—	dBc
Input Return Loss ($V_{DD} = 28\text{ Vdc}$, $P_{out} = 90\text{ W PEP}$, $I_{DQ} = 1000\text{ mA}$, $f_1 = 2110\text{ MHz}$, $f_2 = 2120\text{ MHz}$ and $f_1 = 2160\text{ MHz}$, $f_2 = 2170\text{ MHz}$)	IRL	—	-12	—	dB
P_{out} , 1 dB Compression Point ($V_{DD} = 28\text{ Vdc}$, $I_{DQ} = 1000\text{ mA}$, $f = 2170\text{ MHz}$)	P1dB	—	100	—	W

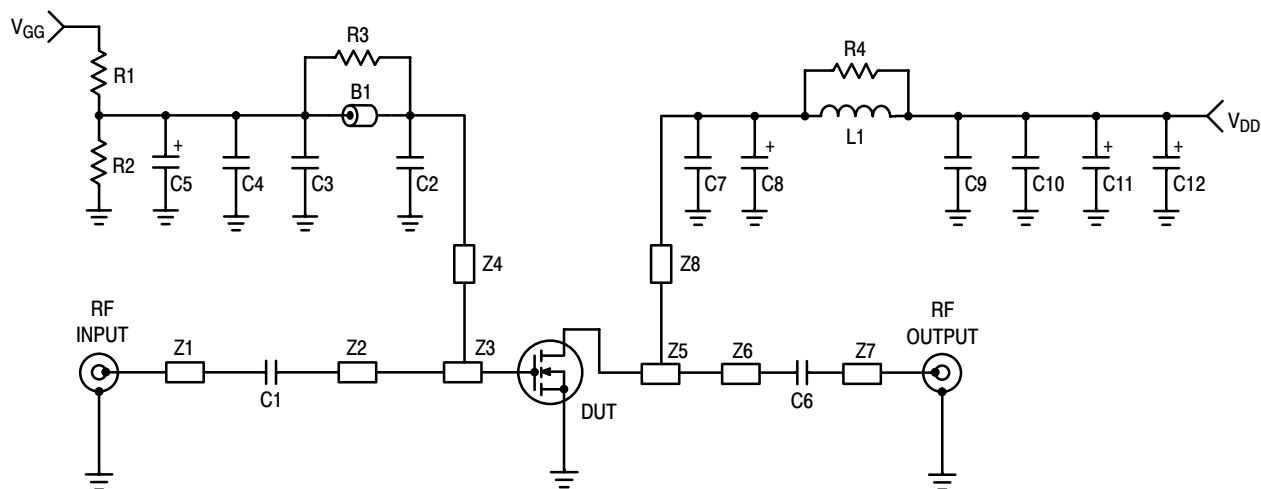

Z1	0.750" x 0.084" Microstrip	Board	0.030" Glass Teflon [®] ,
Z2	1.015" x 0.084" Microstrip	PCB	Keene GX-0300-55-22, $\epsilon_r = 2.55$
Z3	0.480" x 0.800" Microstrip		Etched Circuit Boards
Z4	0.750" x 0.050" Microstrip		MRF21085 Rev. 3, CMR
Z5	0.610" x 0.800" Microstrip		
Z6	0.885" x 0.084" Microstrip		
Z7	0.720" x 0.084" Microstrip		
Z8	0.800" x 0.070" Microstrip		

Figure 1. MRF21085 Test Circuit Schematic

Table 1. MRF21085 Test Circuit Component Designations and Values

Designators	Description
B1	Short Ferrite Bead, Fair Rite, #2743019447
C1, C6	43 pF Chip Capacitors, ATC #100B430JCA500X
C2	10 pF Chip Capacitor, ATC #100B100JCA500X
C3, C9	1000 pF Chip Capacitors, ATC #100B102JCA500X
C4, C10	0.1 μ F Chip Capacitors, Kemet #CDR33BX104AKWS
C5	1.0 μ F Tantalum Chip Capacitor, Kemet #T491C105M050
C7	2.7 pF Chip Capacitor, ATC #100B2R7JCA500X
C8	10 μ F Tantalum Chip Capacitor, Kemet #T495X106K035AS4394
C11, C12	22 μ F Tantalum Chip Capacitors, Kemet #T491X226K035AS4394
L1	1 Turn, #20 AWG, 0.100" ID, Motorola
N1, N2	Type N Flange Mounts, Omni Spectra #3052-1648-10
R1	1.0 k Ω , 1/8 W Chip Resistor
R2	180 k Ω , 1/8 W Chip Resistor
R3, R4	10 Ω , 1/8 W Chip Resistors

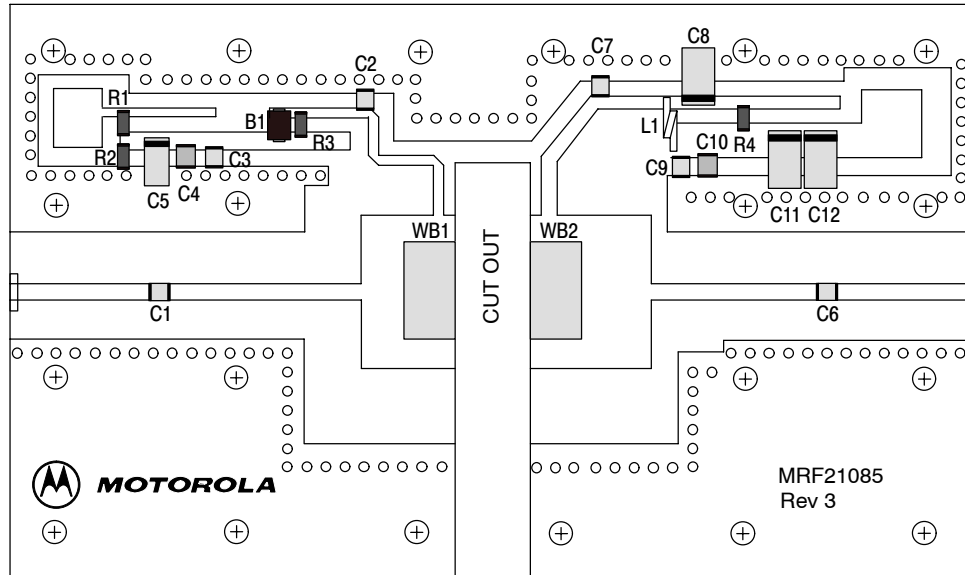

Figure 2. MRF21085 Test Circuit Component Layout

TYPICAL CHARACTERISTICS

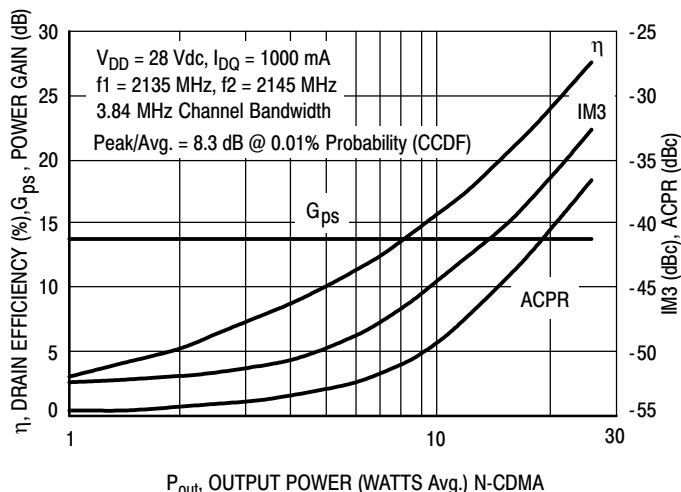

Figure 3. 2-Carrier W-CDMA ACPR, IM3, Power Gain and Drain Efficiency versus Output Power

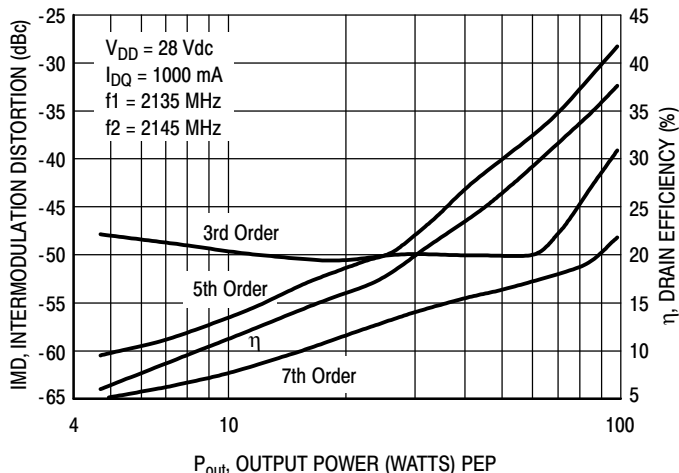

Figure 4. Intermodulation Distortion Products versus Output Power

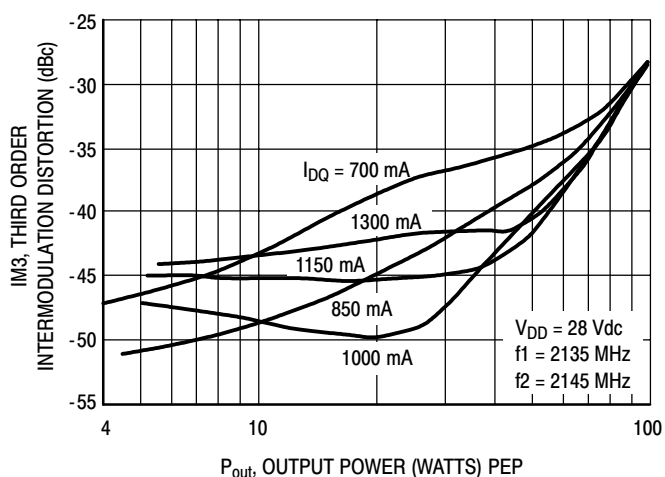

Figure 5. Third Order Intermodulation Distortion versus Output Power

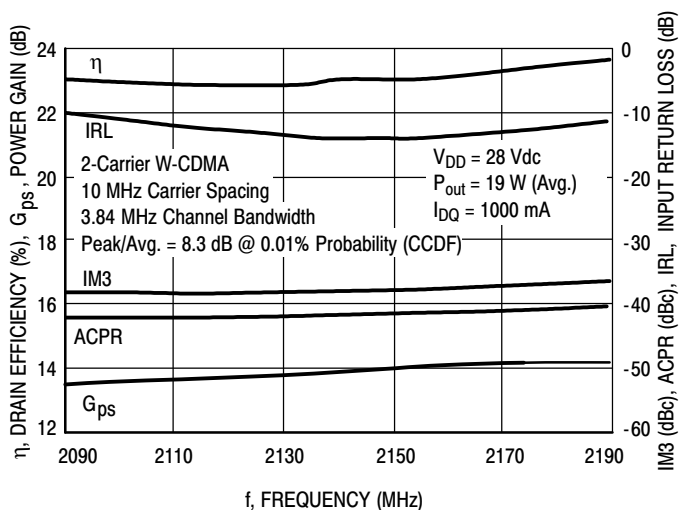

Figure 6. 2-Carrier W-CDMA Broadband Performance

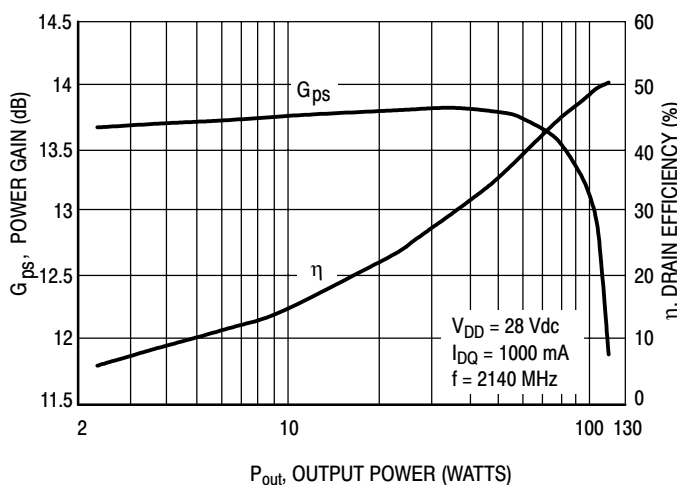

Figure 7. CW Performance

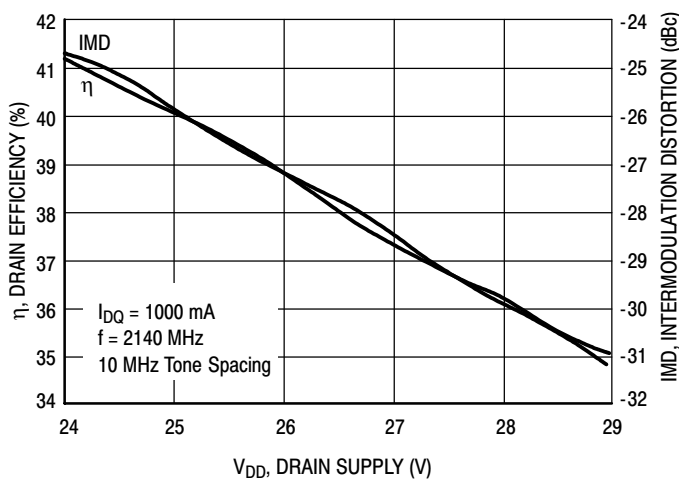

Figure 8. Two-Tone Intermodulation Distortion and Drain Efficiency versus Drain Supply

TYPICAL CHARACTERISTICS

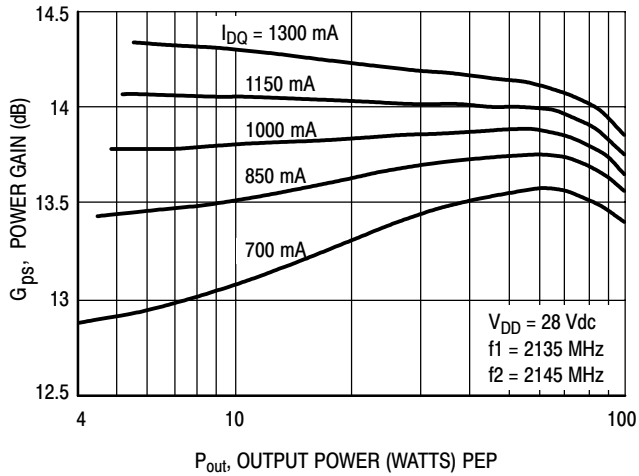

Figure 9. Two-Tone Power Gain versus Output Power

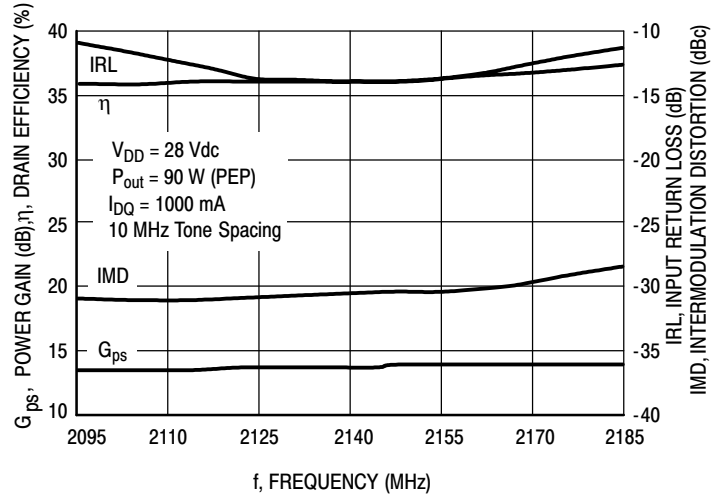

Figure 10. Two-Tone Broadband Performance

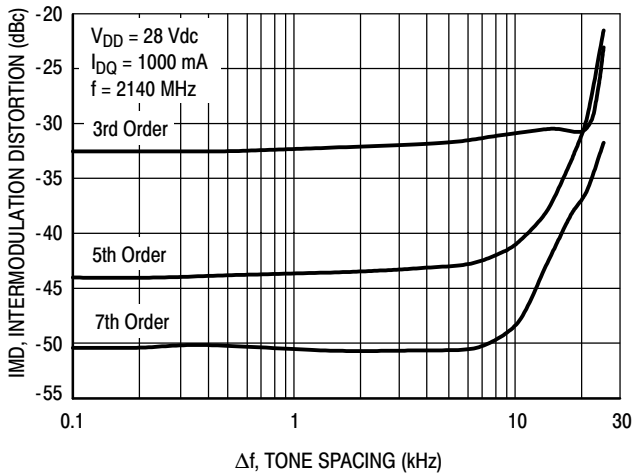

Figure 11. Intermodulation Distortion Products versus Two-Tone Spacing

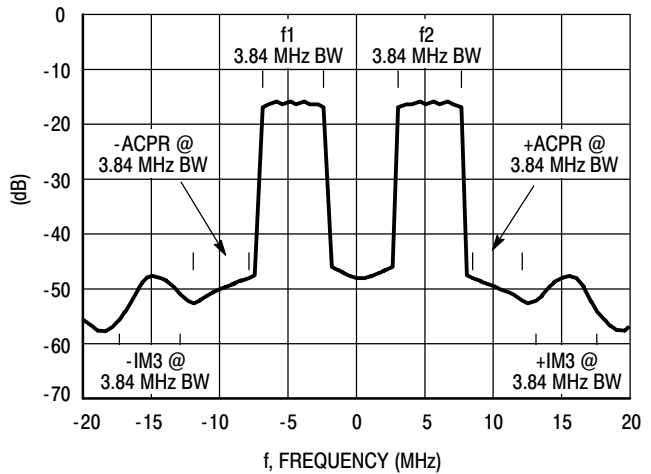
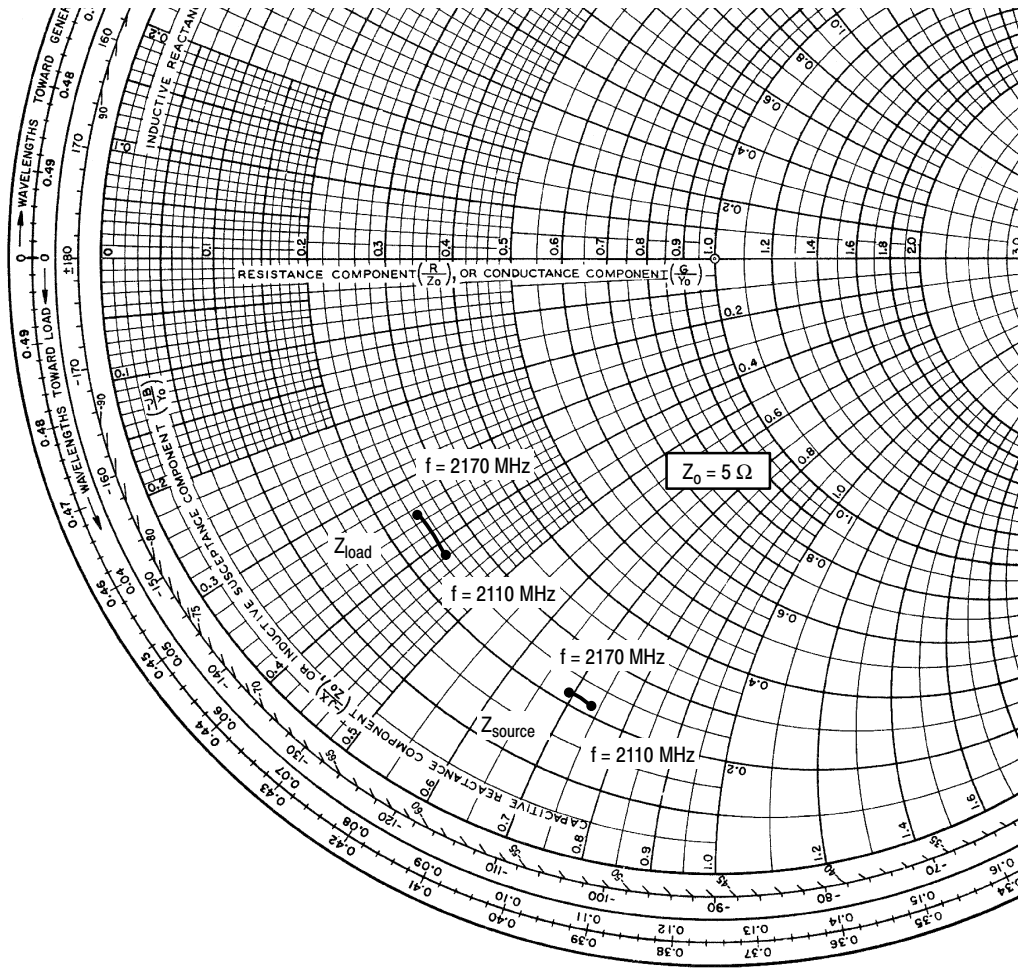

Figure 12. 2-Carrier W-CDMA Spectrum



$V_{DD} = 28 \text{ V}$, $I_{DQ} = 1000 \text{ mA}$, $P_{out} = 19 \text{ W Avg.}$

f MHz	Z_{source} Ω	Z_{load} Ω
2110	$1.10 - j3.71$	$1.23 - j2.10$
2140	$1.11 - j3.57$	$1.26 - j1.92$
2170	$1.12 - j3.40$	$1.25 - j1.76$

Z_{source} = Test circuit impedance as measured from gate to ground.

Z_{load} = Test circuit impedance as measured from drain to ground.

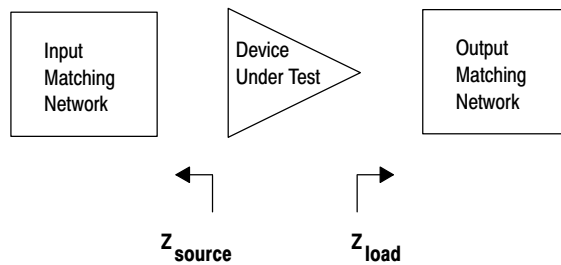
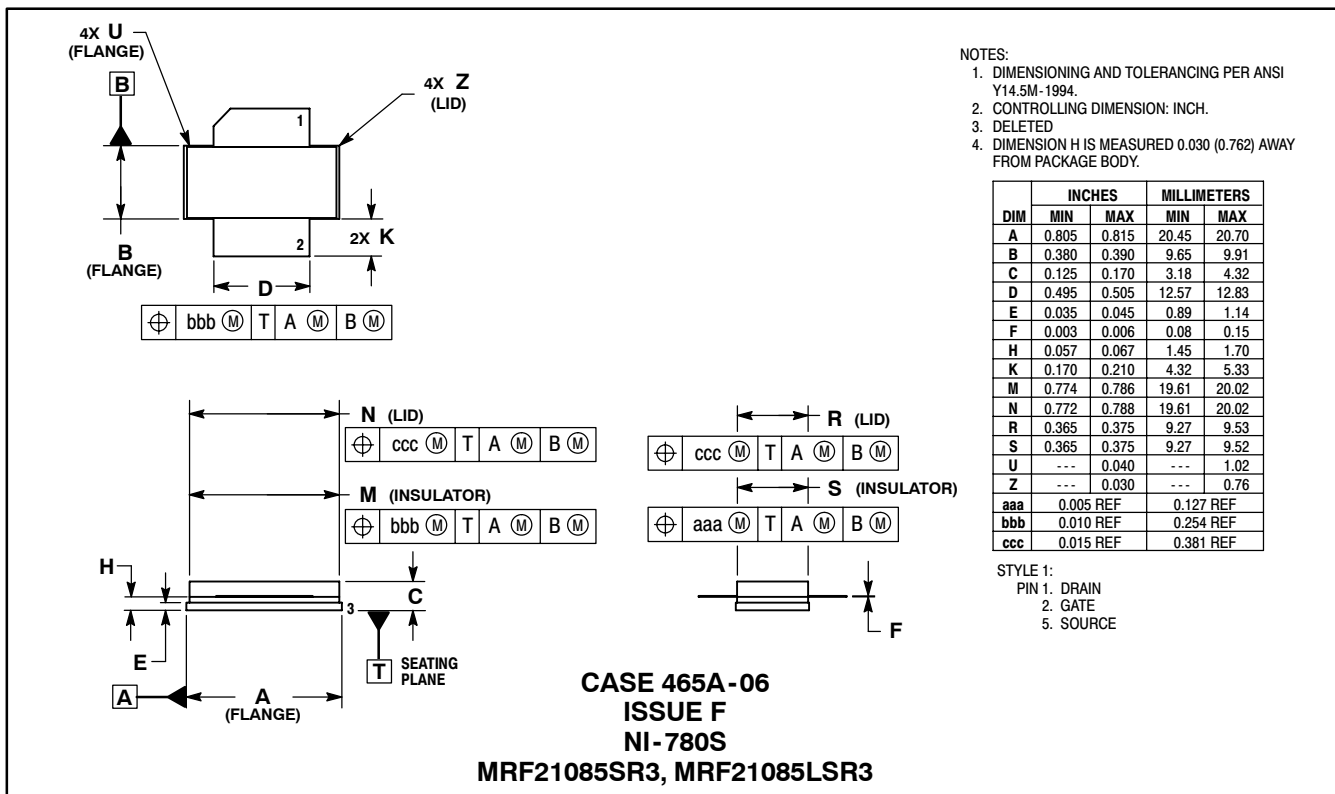
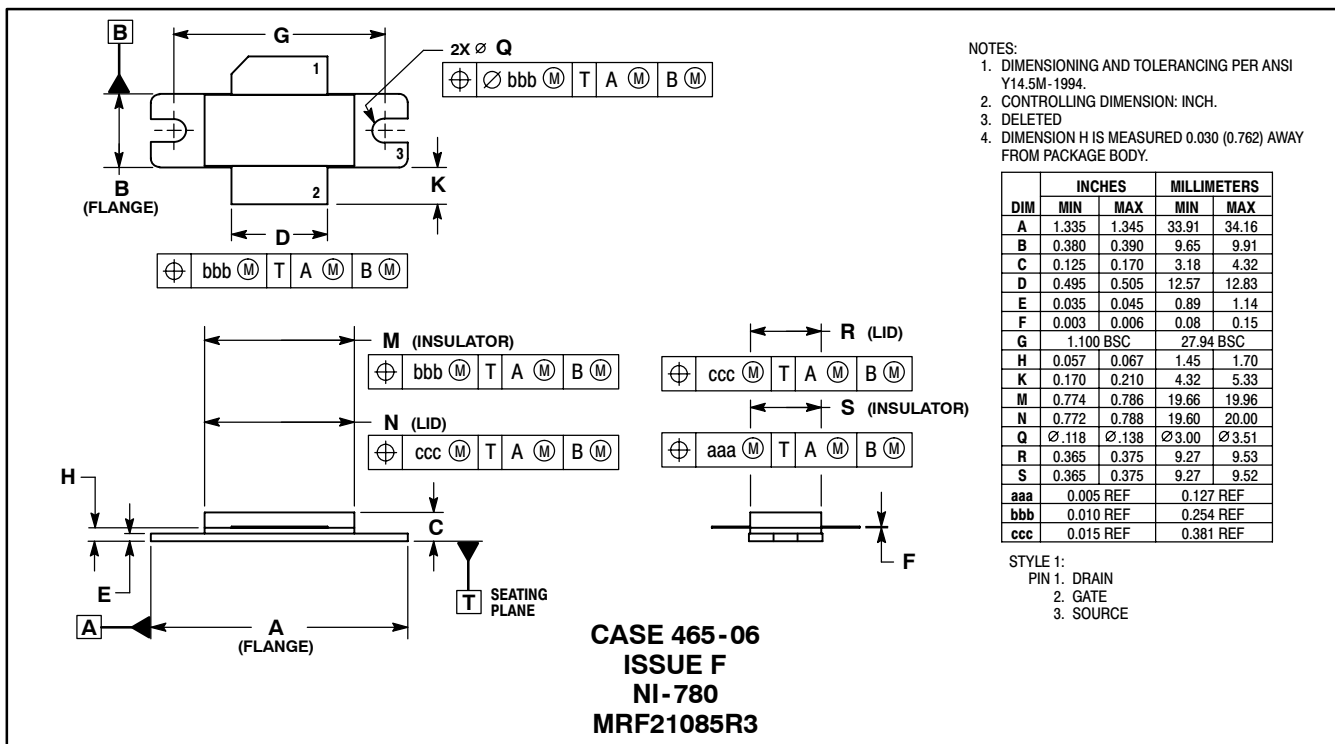

Figure 13. Series Equivalent Input and Output Impedance

NOTES

NOTES

PACKAGE DIMENSIONS



Information in this document is provided solely to enable system and software implementers to use Motorola products. There are no express or implied copyright licenses granted hereunder to design or fabricate any integrated circuits or integrated circuits based on the information in this document.

Motorola reserves the right to make changes without further notice to any products herein. Motorola makes no warranty, representation or guarantee regarding the suitability of its products for any particular purpose, nor does Motorola assume any liability arising out of the application or use of any product or circuit, and specifically disclaims any and all liability, including without limitation consequential or incidental damages. "Typical" parameters that may be provided in Motorola data sheets and/or specifications can and do vary in different applications and actual performance may vary over time. All operating parameters, including "Typicals", must be validated for each customer application by customer's technical experts. Motorola does not convey any license under its patent rights nor the rights of others. Motorola products are not designed, intended, or authorized for use as components in systems intended for surgical implant into the body, or other applications intended to support or sustain life, or for any other application in which the failure of the Motorola product could create a situation where personal injury or death may occur. Should Buyer purchase or use Motorola products for any such unintended or unauthorized application, Buyer shall indemnify and hold Motorola and its officers, employees, subsidiaries, affiliates, and distributors harmless against all claims, costs, damages, and expenses, and reasonable attorney fees arising out of, directly or indirectly, any claim of personal injury or death associated with such unintended or unauthorized use, even if such claim alleges that Motorola was negligent regarding the design or manufacture of the part.

MOTOROLA and the Stylized M Logo are registered in the US Patent and Trademark Office. All other product or service names are the property of their respective owners. Motorola, Inc. is an Equal Opportunity/Affirmative Action Employer.

© Motorola Inc. 2004

HOW TO REACH US:

USA/EUROPE/LOCATIONS NOT LISTED:
Motorola Literature Distribution
P.O. Box 5405, Denver, Colorado 80217
1-800-521-6274 or 480-768-2130

JAPAN: Motorola Japan Ltd.; SPS, Technical Information Center,
3-20-1, Minami-Azabu, Minato-ku, Tokyo 106-8573, Japan
81-3-3440-3569

ASIA/PACIFIC: Motorola Semiconductors H.K. Ltd.; Silicon Harbour Centre,
2 Dai King Street, Tai Po Industrial Estate, Tai Po, N.T., Hong Kong
852-26668334

HOME PAGE: <http://motorola.com/semiconductors>

