



050-367

PRODUCT BRIEF

SIZE 8 ELECTRO-OPTICAL CONTACT TRANSMITTER OR RECEIVER
SMPTE 3G-SDI AND HD-SDI
FRONT INSERT – FRONT RELEASE

REV	DESCRIPTION	DATE	APPROVED
B	Per DCN60097	05/09/2016	SZ/NH/RS
C	Per DCN62204; Edit PRBS Specification to 2 ⁷ -1	10/20/2016	SZ/GC
D	Per DCN63108; Update Min. Extinction Ratio to 5dB per SMPTE Standard	12/13/2016	RAS/GC
E	Per DCN63598; Add part number options to distinguish between 3G-SDI and HD-SDI	01/24/2017	RAS/GC/SZ
F	Per DCN68837; Update receiver overload settings based on SMPTE ST 297:2015	1/26/2018	GC

BF15U2-3711

THIS COPYRIGHTED DOCUMENT IS THE PROPERTY OF GLENAIR, INC. AND IS FURNISHED ON THE CONDITION THAT IT IS NOT TO BE DISCLOSED, REPRODUCED IN WHOLE OR IN PART, OR USED TO SOLICIT QUOTATIONS FROM COMPETITIVE SOURCES, OR USED FOR MANUFACTURE BY ANYONE OTHER THAN GLENAIR, INC. WITHOUT WRITTEN PERMISSION FROM GLENAIR, INC. THE INFORMATION HEREIN HAS BEEN DEVELOPED AT GLENAIR'S EXPENSE AND MAY BE USED FOR ENGINEERING EVALUATION AND INCORPORATION INTO TECHNICAL SPECIFICATIONS AND OTHER DOCUMENTS WHICH SPECIFY PROCUREMENT OF PRODUCTS FROM GLENAIR, INC.

050-367 PRODUCT BRIEF
Size 8 OE Contact, Front Insert/Front Release
3G-SDI and HD-SDI, MMF, 3.3V



Size 8 Cavity Opto-Electronic Contacts, 3G-SDI & HD-SDI, MMF, 3.3V

Glenair 050-367, Size 8 Cavity Opto-electronic contacts transmit and receive differential CML electrical signals over Multimode fiber optic cable that has been optimized for SMPTE 3G-SDI and HD-SDI signals.

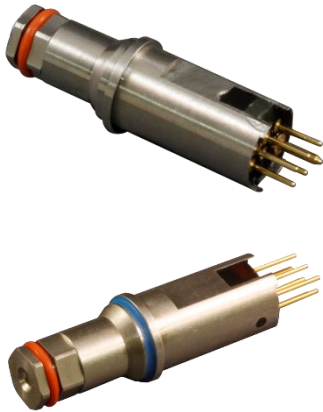

Transmitter size 8 contacts consist of a laser driver with a temperature compensation circuit to maintain optical power over the entire operating temperature range, and a 850nm VCSEL laser. The transmitter has a Tx Disable pin to turn off transmitter output and a Tx Fault pin to signal a fault condition. This laser driver circuit regulates the optical power at a constant level provided the data pattern is relatively DC balanced and can support SMPTE EG 34:2004 Pathological conditions CASE 1, CASE2, and CASE 3 for HD-SDI and 3G-SDI

Receiver size 8 contacts consist of an 850nm PIN Photo Detector, a Transimpedance Amplifier with automatic gain control circuit and a Limiting Amplifier. Differential output data signals are CML compatible. Receiver includes a CMOS compatible Loss of Signal Indicator to prevent invalid data. These receiver designs support SMPTE 424 (3G-SDI) and SMPTE 292 (HD-SDI), with special considerations to comply with the SMPTE Pathological test cases as described in SMPTE EG 34:2004. The receiver support BER <10⁻¹² with Pathological test conditions CASE1, CASE3 and CASE3.

These contacts are designed to operate in for harsh temperature and vibration environments found in Military, Aerospace, Railway, Oil and Gas, and Industrial applications. They can be incorporated into 38999 and other harsh environment connectors.

KEY FEATURES/BENEFITS

- SMPTE EG 34:2004 Compliant to Pathological Conditions CASE 1, CASE 2 and CASE 3.
- SMPTE ST 297:2015 (3G-SDI & HD-SDI)
- SMPTE 424 Compliant (3G-SDI)
- SMPTE 292 Compliant (HD-SDI)
- SFP Compatible Electrical Input signal levels
- 850nm VCSEL support 3G-SDI & HD-SDI
- Industry standard CML input and outputs that make for simple integration on customer host PCB
- Front-release, front-insert, front-removable
- Fits size 8 quadrx cavity for ARINC 600
- Solutions available in 38999 style connectors
- -40°C to +85°C Operating Case Temperature
- Evaluation fixtures available

APPLICATIONS

- Harsh Environment such as: Airborne, Tactical, Railway, Industrial, Oil and Gas and Shipboard applications
 - SMPTE 3G & HD-SDI Video Applications

HOW TO ORDER Table 1 Part Number Options

Part Number	Description
050-367-1-T	HD-SDI Transmitter
050-367-1-R	HD-SDI Receiver
050-367-T	3G-SDI Transmitter
050-367-R	3G-SDI Receiver

050-367 PRODUCT BRIEF
Size 8 OE Contact, Front Insert/Front Release
3G-SDI and HD-SDI, MMF, 3.3V



Ratings and Specifications – HD-SDI VERSION

TABLE 2 ABSOLUTE MAXIMUM RATINGS

Parameter	Symbol	Min	Typ	Max	Units	Notes
Storage Temperature	T _s	-55		+100	°C	
Supply Voltage	V _{cc}	-0.4		3.8	V	V _{ccT} may not differ by more than 0.5V

TABLE 3 OPERATING CONDITIONS

Parameter	Symbol	Min	Typ	Max	Units	Notes
Operating Temperature, Case	T _{op}	-40		+85	°C	
Supply Voltage	V _{cc}	3.135	3.3	3.465	V	
Supply Current	I _{cc}		180	200	mA	Typical @ +85°C
Power Supply Noise (Peak-Peak)	V _{cc_ripple}			100	mV	

TABLE 4 ELECTRO-OPTICAL CHARACTERISTICS – TRANSMITTER

Parameter	Symbol	Min	Typ	Max	Units	Notes
Optical Output Power	P _{OUT}	-8	-5	-3	dBm	850nm VCSEL, 1.5Gbps
Extinction Ratio	E _r	5	10		dB	@1.5Gbps
Optical Wavelength	λ _{OUT}	830	850	860	nm	
Spectral Width, rms	Δλ			0.85	nm	
Relative Intensity Noise	RIN			-117	dB/Hz	
Timing Jitter	T _J			1	UI	SMPTE 292, 1.5 Gbps, Color bar
Alignment Jitter	A _J			0.2	UI	SMPTE 292, 1.5 Gbps, Color bar
Transmitter Differential Input Impedance	Z _{in}		100		Ohms	DC coupled Internally
Differential Input Voltage	V _{in_d}	250		2200	mV _{pp}	CML, 100 ohm

TABLE 5 ELECTRO-OPTICAL CHARACTERISTICS - RECEIVER

Parameter	Symbol	Min	Typ	Max	Units	Notes
Sensitivity, BER 10 ⁻¹² , PRBS 2 ⁷ -1, E _r 10 dB	P _{IN}		-22	-20	dBm	PIN PD @ 1.485 Gbps
Overload, BER 10 ⁻¹² , PRBS 2 ⁷ -1	P _{IN}	-7.5			dBm	@1.485 Gbps *See Notes 1 & 2
Optical Wavelength	λ _{IN}	830		860	nm	
Receiver Differential Output Impedance	Z _{out}		100		Ohms	AC coupled internally
Differential Output Voltage Swing	V _{out_d}	600		1200	mV _{pp}	CML, 100 ohm
LOS Assert Level	LOS		-23	-21	dBm	@1.485 Gbps
LOS Hysteresis	LOS _{HYS}	1.25	2.3		dB	@1.485 Gbps

Notes:

1. Compliant with SMPTE ST 297: 2015.
2. When connecting the 050-367 receivers to transmitters using short length fibers, use 3dB optical attenuators to prevent receiver overload.

050-367 PRODUCT BRIEF
Size 8 OE Contact, Front Insert/Front Release
3G-SDI and HD-SDI, MMF, 3.3V



Ratings and Specifications – HD-SDI VERSION (continued)

TABLE 6 COMPLIANCE SPECIFICATIONS

CHARACTERISTIC	Standard	Condition	Notes
ESD	MIL-STD-883		1000V HBM
Eye Safety	CDRH and IEC-825	Class 1 Laser Product	

050-367 PRODUCT BRIEF
Size 8 OE Contact, Front Insert/Front Release
3G-SDI and HD-SDI, MMF, 3.3V



Ratings and Specifications – 3G-SDI VERSION

TABLE 7 ABSOLUTE MAXIMUM RATINGS

Parameter	Symbol	Min	Typ	Max	Units	Notes
Storage Temperature	T _s	-55		+100	°C	
Supply Voltage	V _{cc}	-0.4		3.8	V	V _{ccT} may not differ by more than 0.5V

TABLE 8 OPERATING CONDITIONS

Parameter	Symbol	Min	Typ	Max	Units	Notes
Operating Temperature, Case	T _{op}	-40		+85	°C	
Supply Voltage	V _{cc}	3.135	3.3	3.465	V	
Supply Current	I _{cc}		180	200	mA	Typical @ +85°C
Power Supply Noise (Peak-Peak)	V _{cc_ripple}			100	mV	

TABLE 9 ELECTRO-OPTICAL CHARACTERISTICS – TRANSMITTER

Parameter	Symbol	Min	Typ	Max	Units	Notes
Optical Output Power	P _{OUT}	-8	-5	-3	dBm	850nm VCSEL, 2.97Gbps
Extinction Ratio	E _r	5	10		dB	@2.97Gbps
Optical Wavelength	λ _{OUT}	830	850	860	nm	
Spectral Width, rms	Δλ			0.85	nm	
Relative Intensity Noise	RIN			-117	dB/Hz	
Timing Jitter	T _J			2	UI	SMPTE 424, 2.97Gbps, Color bar
Alignment Jitter	A _J			0.2	UI	SMPTE 424, 2.97Gbps, Color bar
Transmitter Differential Input Impedance	Z _{in}		100		Ohms	AC coupled Internally
Differential Input Voltage	V _{in_d}	250		2200	mV _{pp}	CML, 100 ohm

TABLE 10 ELECTRO-OPTICAL CHARACTERISTICS - RECEIVER

Parameter	Symbol	Min	Typ	Max	Units	Notes
Sensitivity, BER 10 ⁻¹² , PRBS 2 ⁷ -1, Er 10 dB	P _{IN}		-19	-17	dBm	PIN PD @ 2.970 Gbps
Overload, BER 10 ⁻¹² , PRBS 2 ⁷ -1	P _{IN}	-7.5			dBm	@ 2.970 Gbps *See Notes 1 & 2
Optical Wavelength	λ _{IN}	830		860	nm	
Receiver Differential Output Impedance	Z _{out}		100		Ohms	AC coupled internally
Differential Output Voltage Swing	V _{out_d}	600		1200	mV _{pp}	CML, 100 ohm
LOS Assert Level	LOS		-23	-21	dBm	@ 2.970 Gbps
LOS Hysteresis	LOS _{HYS}	1.25	2.3		dB	@ 2.970 Gbps

Notes:

1. Compliant with SMPTE ST 297: 2015.
2. When connecting the 050-367 receivers to transmitters using short length fibers, use 3dB optical attenuators to prevent receiver overload.

050-367 PRODUCT BRIEF
Size 8 OE Contact, Front Insert/Front Release
3G-SDI and HD-SDI, MMF, 3.3V



Ratings and Specifications – 3G-SDI (continued)

TABLE 11 COMPLIANCE SPECIFICATIONS

CHARACTERISTIC	Standard	Condition	Notes
ESD	MIL-STD-883		1000V HBM
Eye Safety	CDRH and IEC-825	Class 1 Laser Product	

FUNCTIONAL DESCRIPTION

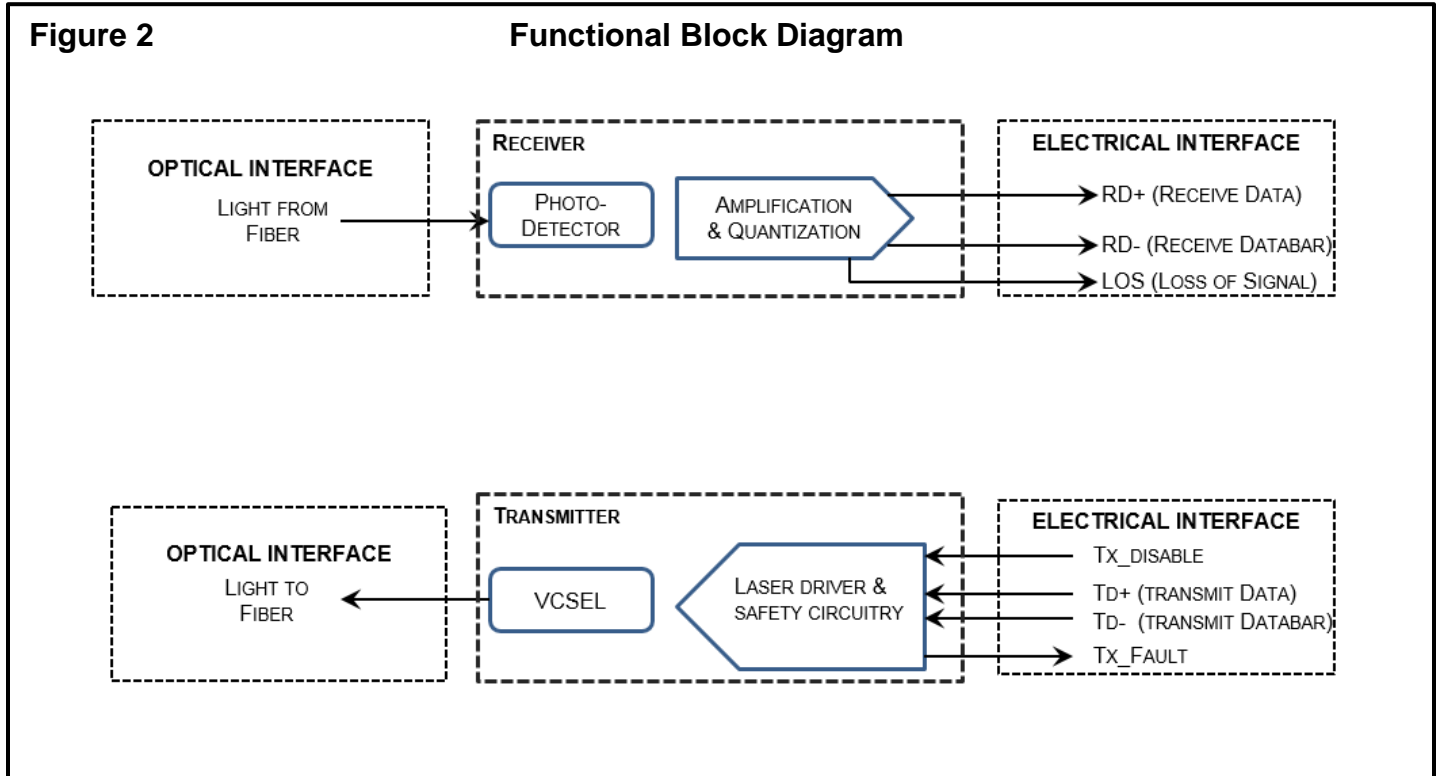

FUNCTIONAL I/O

The Size 8 module is compatible with industry standard differential signals such as CML within the scope of the SFP MSA. The module is DC-coupled and internally terminated.

Figure 3 illustrates a recommended interface circuit to size 8 transmitter/receiver and the supporting Physical Layer integrated circuits.

The transmitter interfaces with the host circuit board through six I/O pins identified by function in Table 7. The transmitter high speed transmit and interfaces require SFP MSA compliant signal lines on the host board. The TX_DISABLE, TX_FAULT require TTL lines on the host board (per SFF-8074i) if used. If an application chooses not to take advantage of the functionality of these pins TX_Disable need to be tied to GND, TX_Fault do not need to be connected.

The receiver interfaces with the host circuit board through six I/O pins identified by function in Table 8. The receiver high speed receive and interfaces require SFP MSA compliant signal lines on the host board.

050-367 PRODUCT BRIEF
 Size 8 OE Contact, Front Insert/Front Release
 3G-SDI and HD-SDI, MMF, 3.3V



FIGURE 3 RECOMMENDED BOARD HOST BOARD SCHEMATIC
 TRANSMITTER

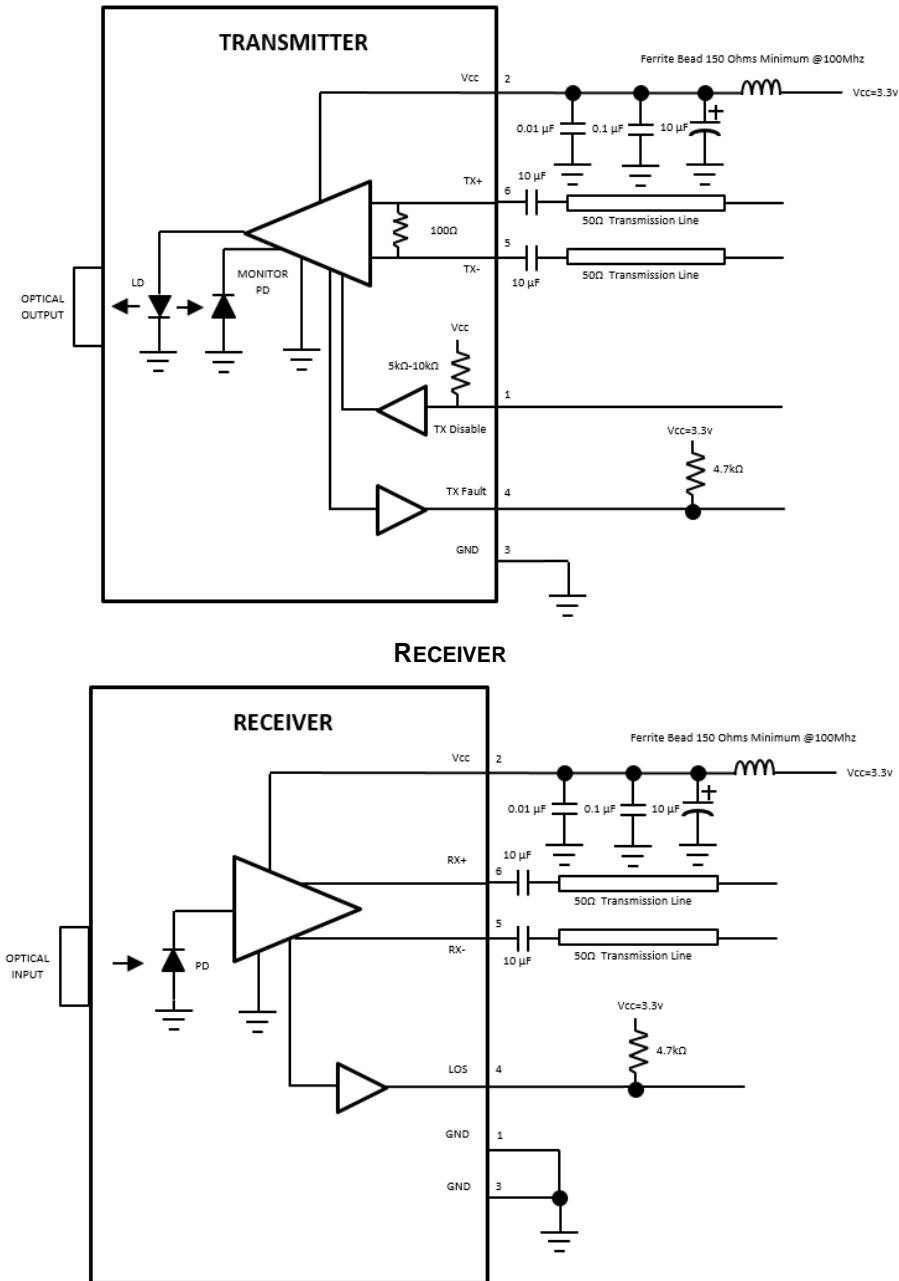

050-367 PRODUCT BRIEF
Size 8 OE Contact, Front Insert/Front Release
3G-SDI and HD-SDI, MMF, 3.3V



Required Host Board Components

A power supply noise rejection filter as describe in SFP MSA is required on the host PCB to meet data sheet performance. This filter incorporates an inductor which should be rated 400 mADC and 1 Ω series resistance or better. It should not be replaced with a ferrite. The required filter is illustrated in Figure 4. Also, the host PCB for the transmitter requires 4.7 K to 10 K Ω pull-up resistors for TX_FAULT.

The host PCB for the receiver requires 4.7 K to 10 K Ω pull-up resistors for RX_LOS.

Fiber Compatibility

The SMPTE link is capable of error free signal detection for 2 to 500 meters with OM3 50/125 μ m fiber, 2 to 170 meters with OM2 50/125 μ m fiber, and at 2 to 60 meters with OM1 62.5/ 125 μ m fiber, for 3G-SDI data rate

Electrostatic Discharge (ESD)

The size 8 contacts are compatible with ESD levels found in typical manufacturing and operating environments as described JEDEC EIA JESD22-A114-A, Class 1C (<2000Volts) HBM. Glenair recommends that devices are handled with ESD precautions to limit exposure to below 500V HBM.

There are two design cases in which immunity to ESD damage is important. The first case is during handling of the components prior to insertion to the host board. It is important to use standard industry ESD handling precautions such as using grounded wrist straps, work benches, and floor mats in ESD controlled areas. The ESD sensitivity of the Glenair device is compatible with typical industry production environments.

The second case to consider is static discharges to the exterior of the host equipment after installation, in which case the electro-optical component may be subject to system-level ESD requirements.

Application Support

To assist in the dual-transmitter design and evaluation process, Glenair offers the following aids:

- Evaluation board & Product Manual
- 3D Step file to support modeling of mechanical fit and routing