

DM74LS170

4 x 4 Register File with Open-Collector Outputs

General Description

The 'LS170 contains 16 high speed, low power, transparent D-type latches arranged as four words of four bits each, to function as a 4×4 register file. Separate read and write inputs, both address and enable, allow simultaneous read and write operation. Open-collector outputs make it possible to connect up to 128 outputs in a wired-AND configuration to increase the word capacity up to 512 words. Any number of these devices can be operated in parallel to generate an n-bit length. The '670 provides a similar function to this device but it features TRI-STATE® outputs.

Features

- Simultaneous read/write operation
- Expandable to 512 words of n-bits
- Typical access time of 20 ns
- Low leakage open-collector outputs for expansion

Connection Diagram

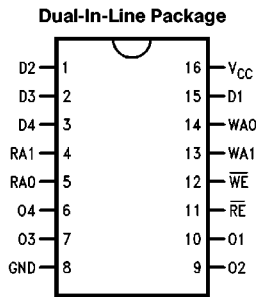

TL/F/9820-1

Order Number DM74LS170WM or DM74LS170N
See NS Package Number M16B or N16E

Logic Symbol

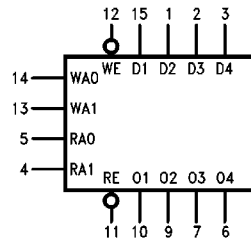

V_{CC} = Pin 16
GND = Pin 8

TL/F/9820-2

Pin Names	Description
D1-D4	Data Inputs
WA0-WA1	Write Address Inputs
\overline{WE}	Write Enable Input (Active LOW)
RA0, RA1	Read Address Inputs
\overline{RE}	Read Enable Input (Active LOW)
O1-O4	Data Outputs

TRI-STATE® is a registered trademark of National Semiconductor Corporation.

Absolute Maximum Ratings (Note)

Supply Voltage	7V
Input Voltage	7V
Operating Free Air Temperature Range	0°C to +70°C
DM74	0°C to +70°C
Storage Temperature Range	-65°C to +150°C

Note: The "Absolute Maximum Ratings" are those values beyond which the safety of the device cannot be guaranteed. The device should not be operated at these limits. The parametric values defined in the "Electrical Characteristics" table are not guaranteed at the absolute maximum ratings. The "Recommended Operating Conditions" table will define the conditions for actual device operation.

Recommended Operating Conditions

Symbol	Parameter	DM74LS170			Units
		Min	Nom	Max	
V _{CC}	Supply Voltage	4.75	5	5.25	V
V _{IH}	High Level Input Voltage	2			V
V _{IL}	Low Level Input Voltage			0.8	V
V _{OH}	High Level Output Voltage			5.5	V
I _{OL}	Low Level Output Current			8	mA
T _A	Free Air Operating Temperature	0		70	°C
t _s	Setup Time HIGH or LOW Dn to Rising \overline{WE}	10			ns
t _h	Hold Time HIGH or LOW Dn to Rising \overline{WE}	5.0			ns
t _s	Setup Time HIGH or LOW WAn to Falling \overline{WE}	10			ns
t _h	Hold Time HIGH or LOW WAn to Rising \overline{WE}	5.0			ns
t _{w(L)}	\overline{WE} or \overline{RE} Pulse Width LOW	25			ns

Electrical Characteristics

Over recommended operating free air temperature range (unless otherwise noted)

Symbol	Parameter	Conditions	Min	Typ (Note 1)	Max	Units
V _I	Input Clamp Voltage	V _{CC} = Min, I _I = -18 mA			-1.5	V
I _{CEX}	High Level Output Current	V _{CC} = Min, V _O = 5.5V			20	μA
V _{OL}	Low Level Output Voltage	V _{CC} = Min, I _{OL} = Max, V _{IH} = Min	DM74	0.35	0.5	V
		I _{OL} = 4 mA, V _{CC} = Min	DM74	0.25	0.4	
I _I	Input Current @ Max Input Voltage	V _{CC} = Max, V _I = 7V	Dns, RAO, WA0		0.1	mA
			\overline{WE} , \overline{RE}		0.2	
I _{IH}	High Level Input Current	V _{CC} = Max, V _I = 2.7V	Inputs		20	μA
			\overline{RE} , \overline{WE}		40	
I _{IL}	Low Level Input Current	V _{CC} = Max, V _I = 0.4V	\overline{RE} , \overline{WE}	-0.06	-0.8	mA
			RA1, WA1	-0.05	-0.4	
			DATA, RAO, WA0	-0.03	-0.4	
I _{OS}	Short Circuit Output Current	V _{CC} = Max (Note 2)	DM74	-20	-100	mA
I _{CC}	Supply Current	V _{CC} = Max, Dn, \overline{WE} , \overline{RE} = 4.5V, WAn, RAn = GND			40	mA

Note 1: All typicals are at V_{CC} = 5V, T_A = 25°C.

Note 2: Not more than one output should be shorted at a time, and the duration should not exceed one second.

Switching Characteristics

$V_{CC} = +5.0V$, $T_A = +25^\circ C$

Symbol	Parameter	Conditions	$R_L = 2k, C_L = 15 pF$		Units
			Min	Max	
t_{PLH} t_{PHL}	Propagation Delay* RA0 or RA1 to On			35	ns
t_{PLH} t_{PHL}	Propagation Delay \overline{RE} to On			30	ns
t_{PLH} t_{PHL}	Propagation Delay WE to On			35	ns
t_{PLH} t_{PHL}	Propagation Delay Dn to On			35	ns

*Measured at least 25 ns after entry of new data at selected location.

Switching Waveforms

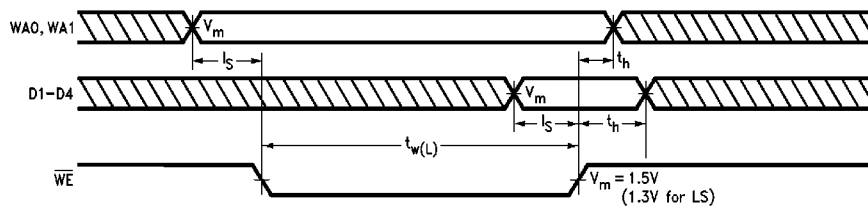

FIGURE a

TL/F/9820-4

Write Function Table

Write Inputs			D Inputs to
\overline{WE}	WA1	WA0	
L	L	L	Word 0
L	L	H	Word 1
L	H	L	Word 2
L	H	H	Word 3
H	X	X	None (Hold)

H = HIGH Voltage Level

L = LOW Voltage Level

Read Function Table

Read Inputs			Outputs from
\overline{RE}	RA1	RA0	
L	L	L	Word 0
L	L	H	Word 1
L	H	L	Word 2
L	H	H	Word 3
H	X	X	None (High Z)

X = Immaterial

Logic Diagram

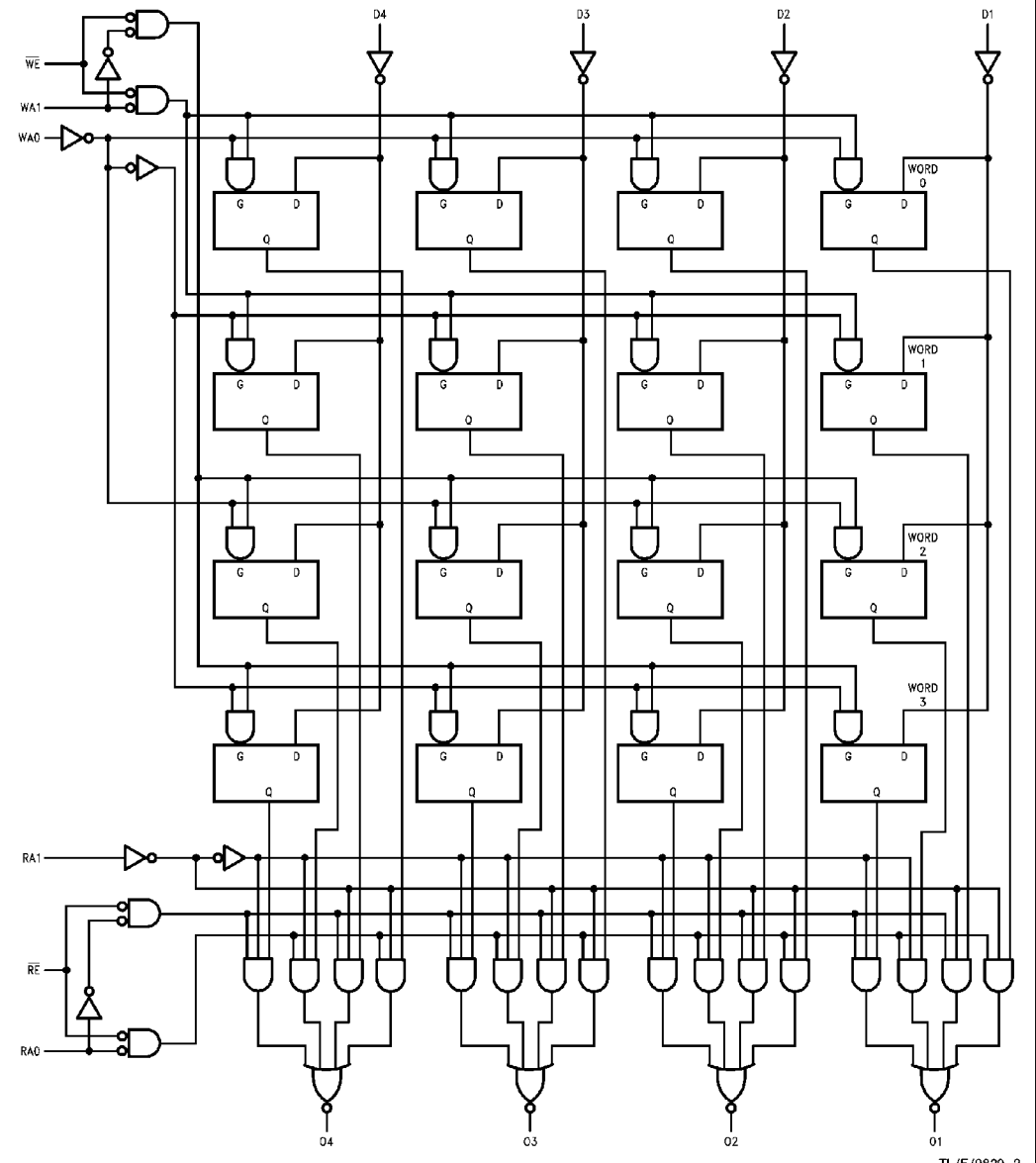

TL/F/9620-3

Physical Dimensions inches (millimeters) (Continued)

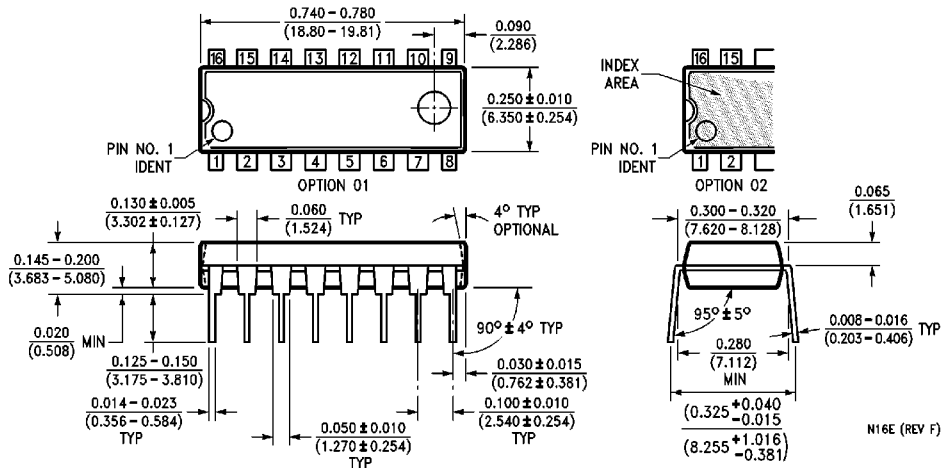

16-Lead Molded Dual-In-Line Package (N)
Order Number DM74LS170N (N)
NS Package Number N16E

LIFE SUPPORT POLICY

NATIONAL'S PRODUCTS ARE NOT AUTHORIZED FOR USE AS CRITICAL COMPONENTS IN LIFE SUPPORT DEVICES OR SYSTEMS WITHOUT THE EXPRESS WRITTEN APPROVAL OF THE PRESIDENT OF NATIONAL SEMICONDUCTOR CORPORATION. As used herein:

1. Life support devices or systems are devices or systems which, (a) are intended for surgical implant into the body, or (b) support or sustain life, and whose failure to perform, when properly used in accordance with instructions for use provided in the labeling, can be reasonably expected to result in a significant injury to the user.
2. A critical component is any component of a life support device or system whose failure to perform can be reasonably expected to cause the failure of the life support device or system, or to affect its safety or effectiveness.



National Semiconductor Corporation
 1111 West Bardin Road
 Arlington, TX 76017
 Tel: 1(800) 272-9959
 Fax: 1(800) 737-7018

National Semiconductor Europe
 Fax: (+49) 0-180-530 85 86
 Email: onjwge@tevm2.nsc.com
 Deutsch Tel: (+49) 0-180-530 85 85
 English Tel: (+49) 0-180-532 78 32
 Français Tel: (+49) 0-180-532 93 58
 Italiano Tel: (+49) 0-180-534 16 80

National Semiconductor Hong Kong Ltd.
 13th Floor, Straight Block,
 Ocean Centre, 5 Canton Rd.
 Tsimshatsui, Kowloon
 Hong Kong
 Tel: (852) 2737-1600
 Fax: (852) 2736-9960

National Semiconductor Japan Ltd.
 Tel: 81-043-299-2309
 Fax: 81-043-299-2408

National does not assume any responsibility for use of any circuitry described, no circuit patent licenses are implied and National reserves the right at any time without notice to change said circuitry and specifications.