

ML610407/ML610408/ML610409 User's Manual

NOTES

No copying or reproduction of this document, in part or in whole, is permitted without the consent of LAPIS Semiconductor Co., Ltd. The content specified herein is subject to change for improvement without notice.

The content specified herein is for the purpose of introducing LAPIS Semiconductor 's products (hereinafter "Products"). If you wish to use any such Product, please be sure to refer to the specifications, which can be obtained from LAPIS Semiconductor upon request.

Examples of application circuits, circuit constants and any other information contained herein illustrate the standard usage and operations of the Products. The peripheral conditions must be taken into account when designing circuits for mass production.

Great care was taken in ensuring the accuracy of the information specified in this document. However, should you incur any damage arising from any inaccuracy or misprint of such information, LAPIS Semiconductor shall bear no responsibility for such damage.

The technical information specified herein is intended only to show the typical functions of and examples of application circuits for the Products. LAPIS Semiconductor does not grant you, explicitly or implicitly, any license to use or exercise intellectual property or other rights held by LAPIS Semiconductor and other parties. LAPIS Semiconductor shall bear no responsibility whatsoever for any dispute arising from the use of such technical information.

The Products specified in this document are intended to be used with general-use electronic equipment or devices (such as audio visual equipment, office-automation equipment, communication devices, electronic appliances and amusement devices).

The Products specified in this document are not designed to be radiation tolerant.

While LAPIS Semiconductor always makes efforts to enhance the quality and reliability of its Products, a Product may fail or malfunction for a variety of reasons.

Please be sure to implement in your equipment using the Products safety measures to guard against the possibility of physical injury, fire or any other damage caused in the event of the failure of any Product, such as derating, redundancy, fire control and fail-safe designs. LAPIS Semiconductor shall bear no responsibility whatsoever for your use of any Product outside of the prescribed scope or not in accordance with the instruction manual.

The Products are not designed or manufactured to be used with any equipment, device or system which requires an extremely high level of reliability the failure or malfunction of which may result in a direct threat to human life or create a risk of human injury (such as a medical instrument, transportation equipment, aerospace machinery, nuclear-reactor controller, fuel-controller or other safety device). LAPIS Semiconductor shall bear no responsibility in any way for use of any of the Products for the above special purposes. If a Product is intended to be used for any such special purpose, please contact a ROHM sales representative before purchasing.

If you intend to export or ship overseas any Product or technology specified herein that may be controlled under the Foreign Exchange and the Foreign Trade Law, you will be required to obtain a license or permit under the Law.

Copyright 2011 – 2012 LAPIS Semiconductor Co., Ltd.

Preface

This manual describes the operation of the hardware of the 8-bit microcontroller ML610407/ML610408/ML610409.

The following manuals are also available. Read them as necessary.

- nX-U8/100 Core Instruction Manual
Description on the basic architecture and the each instruction of the nX-U8/100 Core.
- MACU8 Assembler Package User's Manual
Description on the method of operating the relocatable assembler, the linker, the librarian, and the object converter and also on the specifications of the assembler language.
- CCU8 User's Manual
Description on the method of operating the compiler.
- CCU8 Programming Guide
Description on the method of programming.
- CCU8 Language Reference
Description on the language specifications.
- DTU8 Debugger User's Manual
Description on the method of operating the debugger DTU8.
- IDEU8 User's Manual
Description on the integrated development environment IDEU8.

Notation

| Classification | Notation | Description |
|-----------------|---|---|
| ◆ Numeric value | xxh, xxH xxb | Indicates a hexadecimal number. x: Any value in the range of 0 to F Indicates a binary number; “b” may be omitted. x: A value 0 or 1 |
| ◆ Unit | word, W byte, B nibble, N mega-, M kilo-, K kilo-, k milli-, m micro-, μ nano-, n second, s (lower case) | 1 word = 16 bits 1 byte = 8 bits 1 nibble = 4 bits 10^6 $2^{10} = 1024$ $10^3 = 1000$ 10^{-3} 10^{-6} 10^{-9} second |
| ◆ Terminology | “H” level, “1” level “L” level, “0” level | Indicates high voltage signal levels V_{IH} and V_{OH} as specified by the electrical characteristics. Indicates low voltage signal levels V_{IL} and V_{OL} as specified by the electrical characteristics. |

◆ Register description

R/W: Indicates that Read/Write attribute. “R” indicates that data can be read and “W” indicates that data can be written. “R/W” indicates that data can be read or written.

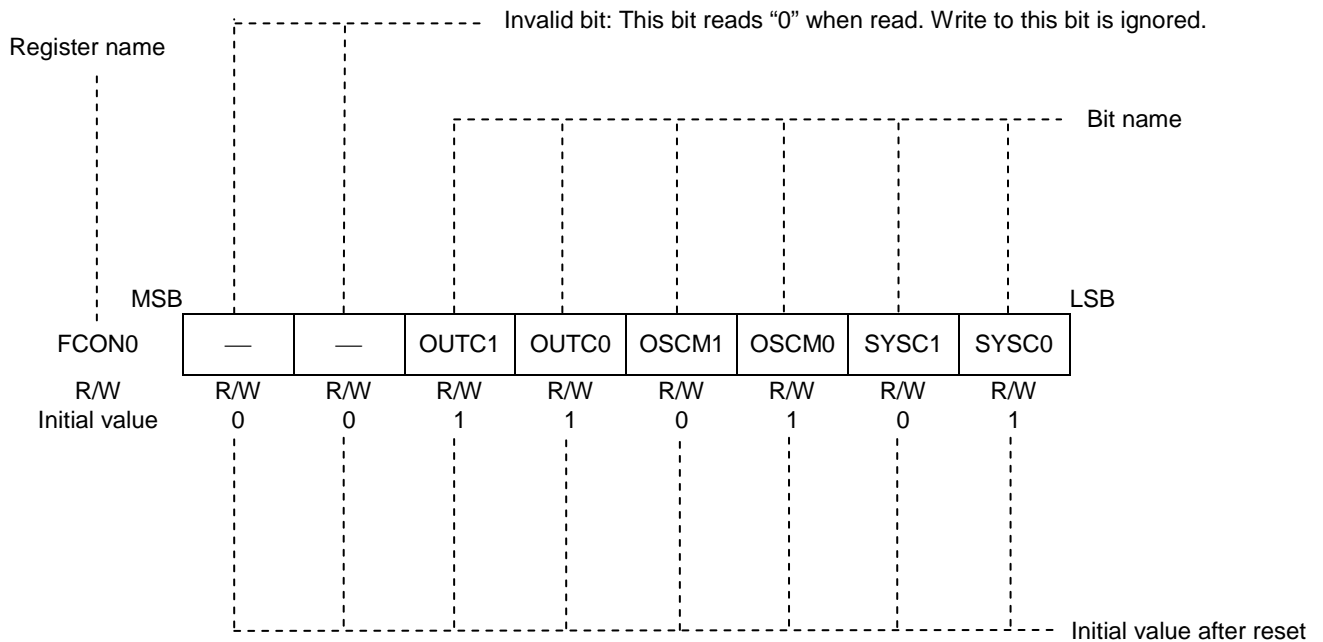

Table of Contents

Chapter 1

| | |
|---|------|
| 1. Overview | 1-1 |
| 1.1 Features | 1-1 |
| 1.2 Configuration of Functional Blocks | 1-4 |
| 1.2.1 Block Diagram of ML610407/ML610408/ML610409 | 1-4 |
| 1.3 Pins | 1-5 |
| 1.3.1 Pin Layout..... | 1-5 |
| 1.3.1.1 Pin Layout of ML610407 TQFP Package | 1-5 |
| 1.3.1.2 Pin Layout of ML610408 TQFP Package | 1-6 |
| 1.3.1.3 Pin Layout of ML610409 TQFP Package | 1-7 |
| 1.3.1.4 Pin Layout of ML610407 Chip..... | 1-8 |
| 1.3.1.5 Pin Layout of ML610408 Chip..... | 1-9 |
| 1.3.1.6 Pin Layout of ML610409 Chip..... | 1-10 |
| 1.3.1.7 Pad Coordinates of ML610407/ML610408/M610409 Chip | 1-11 |
| 1.3.2 List of Pins..... | 1-12 |
| 1.3.3 Pin Descriptions..... | 1-15 |
| 1.3.4 Handling of Unused Pins | 1-19 |

Chapter 2

| | |
|---|-----|
| 2. CPU and Memory Space | 2-1 |
| 2.1 Overview | 2-1 |
| 2.2 Program Memory Space | 2-1 |
| 2.3 Data Memory Space | 2-2 |
| 2.4 Instruction Length..... | 2-3 |
| 2.5 Data Type | 2-3 |
| 2.6 Description of Registers | 2-4 |
| 2.6.1 List of Registers | 2-4 |
| 2.6.2 Data Segment Register (DSR) | 2-5 |

Chapter 3

| | |
|--|-----|
| 3. Reset Function | 3-1 |
| 3.1 Overview | 3-1 |
| 3.1.1 Features..... | 3-1 |
| 3.1.2 Configuration..... | 3-1 |
| 3.1.3 List of Pins..... | 3-1 |
| 3.2 Description of Registers | 3-2 |
| 3.2.1 List of Registers | 3-2 |
| 3.2.2 Reset Status Register (RSTAT)..... | 3-2 |
| 3.3 Description of Operation | 3-3 |
| 3.3.1 Operation of System Reset Mode | 3-3 |

Chapter 4

| | |
|--|------|
| 4. MCU Control Function..... | 4-1 |
| 4.1 Overview | 4-1 |
| 4.1.1 Features..... | 4-1 |
| 4.1.2 Configuration..... | 4-1 |
| 4.2 Description of Registers | 4-2 |
| 4.2.1 List of Registers..... | 4-2 |
| 4.2.2 Stop Code Acceptor (STPACP)..... | 4-3 |
| 4.2.3 Standby Control Register (SBYCON)..... | 4-4 |
| 4.2.4 Block Control Register 0 (BLKCON0)..... | 4-5 |
| 4.2.5 Block Control Register 1 (BLKCON1)..... | 4-6 |
| 4.2.6 Block Control Register 2 (BLKCON2)..... | 4-7 |
| 4.2.7 Block Control Register 3 (BLKCON3)..... | 4-8 |
| 4.2.8 Block Control Register 4 (BLKCON4)..... | 4-9 |
| 4.3 Description of Operation | 4-10 |
| 4.3.1 Program Run Mode..... | 4-10 |
| 4.3.2 HALT Mode..... | 4-10 |
| 4.3.3 STOP mode..... | 4-11 |
| 4.3.3.1 STOP Mode When CPU Operates with Low-Speed Clock..... | 4-11 |
| 4.3.3.2 STOP Mode When CPU Operates with High-Speed Clock..... | 4-12 |
| 4.3.4 Note on Return Operation from STOP/HALT Mode..... | 4-13 |
| 4.3.5 Block Control Function | 4-14 |

Chapter 5

| | |
|---|------|
| 5. Interrupts..... | 5-1 |
| 5.1 Overview | 5-1 |
| 5.1.1 Features..... | 5-1 |
| 5.2 Description of Registers | 5-2 |
| 5.2.1 List of Registers..... | 5-2 |
| 5.2.2 Interrupt Enable Register 1 (IE1)..... | 5-3 |
| 5.2.3 Interrupt Enable Register 2 (IE2)..... | 5-4 |
| 5.2.4 Interrupt Enable Register 3 (IE3)..... | 5-5 |
| 5.2.5 Interrupt Enable Register 4 (IE4)..... | 5-6 |
| 5.2.6 Interrupt Enable Register 5 (IE5)..... | 5-7 |
| 5.2.7 Interrupt Enable Register 6 (IE6)..... | 5-8 |
| 5.2.8 Interrupt Enable Register 7 (IE7)..... | 5-9 |
| 5.2.9 Interrupt Request Register 0 (IRQ0)..... | 5-10 |
| 5.2.10 Interrupt Request Register 1 (IRQ1)..... | 5-11 |
| 5.2.11 Interrupt Request Register 2 (IRQ2)..... | 5-13 |
| 5.2.12 Interrupt Request Register 3 (IRQ3)..... | 5-14 |
| 5.2.13 Interrupt Request Register 4 (IRQ4)..... | 5-15 |
| 5.2.14 Interrupt Request Register 5 (IRQ5)..... | 5-16 |
| 5.2.15 Interrupt Request Register 6 (IRQ6)..... | 5-17 |
| 5.2.16 Interrupt Request Register 7 (IRQ7)..... | 5-18 |
| 5.3 Description of Operation | 5-19 |
| 5.3.1 Maskable Interrupt Processing..... | 5-20 |
| 5.3.2 Non-Maskable Interrupt Processing | 5-20 |
| 5.3.3 Software Interrupt Processing..... | 5-20 |
| 5.3.4 Notes on Interrupt Routine | 5-21 |
| 5.3.5 Interrupt Disable State | 5-24 |

Chapter 6

| | |
|---|------|
| 6. Clock Generation Circuit..... | 6-1 |
| 6.1 Overview | 6-1 |
| 6.1.1 Features..... | 6-1 |
| 6.1.2 Configuration..... | 6-1 |
| 6.1.3 List of Pins..... | 6-2 |
| 6.2 Description of Registers | 6-3 |
| 6.2.1 List of Registers..... | 6-3 |
| 6.2.2 Frequency Control Register 0 (FCON0)..... | 6-4 |
| 6.2.3 Frequency Control Register 1 (FCON1)..... | 6-5 |
| 6.3 Description of Operation | 6-6 |
| 6.3.1 Low-Speed Clock | 6-6 |
| 6.3.1.1 Low-Speed Clock Generation Circuit..... | 6-6 |
| 6.3.1.2 Operation of Low-Speed Clock Generation Circuit | 6-7 |
| 6.3.2 High-speed clock | 6-8 |
| 6.3.2.1 High-Speed Clock Generation Circuit..... | 6-8 |
| 6.3.2.2 Operation of High-Speed Clock Generation Circuit..... | 6-9 |
| 6.3.3 Switching of System Clock..... | 6-10 |
| 6.4 Specifying Port Registers | 6-11 |
| 6.4.1 Functioning P21 (OUTCLK) as the high-speed clock output | 6-11 |
| 6.4.2 Functioning P20 (LSCLK) as the low-speed clock output | 6-12 |

Chapter 7

| | |
|--|------|
| 7. Time Base Counter | 7-1 |
| 7.1 Overview | 7-1 |
| 7.1.1 Features..... | 7-1 |
| 7.1.2 Configuration..... | 7-1 |
| 7.2 Description of Registers | 7-3 |
| 7.2.1 List of Registers..... | 7-3 |
| 7.2.2 Low-Speed Time Base Counter Register (LTBR) | 7-4 |
| 7.2.3 High-Speed Time Base Counter Divide Register (HTBDR)..... | 7-5 |
| 7.2.4 Low-Speed Time Base Counter Frequency Adjustment Registers L and H (LTBADJL, LTBADJH) | 7-6 |
| 7.3 Description of Operation | 7-7 |
| 7.3.1 Low-speed Time Base Counter..... | 7-7 |
| 7.3.2 High-Speed Time Base Counter | 7-8 |
| 7.3.3 Low-Speed Time Base Counter Frequency Adjustment Function..... | 7-9 |
| 7.3.4 A signal generation for 16-bit timer 2-3 frequency measurement mode..... | 7-10 |

Chapter 8

| | |
|---|-----|
| 8. Capture | 8-1 |
| 8.1 Overview..... | 8-1 |
| 8.1.1 Features..... | 8-1 |
| 8.1.2 Configuration..... | 8-1 |
| 8.1.3 List of Pins..... | 8-1 |
| 8.2 Description of Registers | 8-2 |
| 8.2.1 List of Registers..... | 8-2 |
| 8.2.2 Capture Control Register (CAPCON) | 8-3 |
| 8.2.3 Capture Status Register (CAPSTAT) | 8-4 |
| 8.2.4 Capture Data Register 0 (CAPR0)..... | 8-5 |
| 8.2.5 Capture Data Register 1 (CAPR1)..... | 8-6 |

| | |
|--|-----|
| 8.2.6 Capture Time Base Data Register (CAPTB)..... | 8-7 |
| 8.3 Description of Operation | 8-8 |

Chapter 9

| | |
|---|------|
| 9. Timer | 9-1 |
| 9.1 Overview | 9-1 |
| 9.1.1 Features..... | 9-1 |
| 9.1.2 Configuration..... | 9-1 |
| 9.1.3 List of Pins..... | 9-2 |
| 9.2 Description of Registers | 9-3 |
| 9.2.1 List of Registers..... | 9-3 |
| 9.2.2 Timer 0 Data Register (TM0D) | 9-4 |
| 9.2.3 Timer 1 Data Register (TM1D) | 9-5 |
| 9.2.4 Timer 2 Data Register (TM2D) | 9-6 |
| 9.2.5 Timer 3 Data Register (TM3D)..... | 9-7 |
| 9.2.6 Timer 0 Counter Register (TM0C)..... | 9-8 |
| 9.2.7 Timer 1 Counter Register (TM1C)..... | 9-9 |
| 9.2.8 Timer 2 Counter Register (TM2C)..... | 9-10 |
| 9.2.9 Timer 3 Counter Register (TM3C)..... | 9-11 |
| 9.2.10 Timer 0 Control Register 0 (TM0CON0)..... | 9-12 |
| 9.2.11 Timer 1 Control Register 0 (TM1CON0)..... | 9-13 |
| 9.2.12 Timer 2 Control Register 0 (TM2CON0)..... | 9-14 |
| 9.2.13 Timer 3 Control Register 0 (TM3CON0)..... | 9-15 |
| 9.2.14 Timer 0 Control Register 1 (TM0CON1)..... | 9-16 |
| 9.2.15 Timer 1 Control Register 1 (TM1CON1)..... | 9-17 |
| 9.2.16 Timer 2 Control Register 1 (TM2CON1)..... | 9-18 |
| 9.2.17 Timer 3 Control Register 1 (TM3CON1)..... | 9-19 |
| 9.3 Description of Operation | 9-20 |
| 9.3.1 Timer mode operation..... | 9-20 |
| 9.3.2 16-bit timer frequency measurement mode operation | 9-21 |
| 9.3.3 16-bit timer frequency measurement mode application for setting uart baud-rate | 9-23 |
| 9.4 Operating Timers by External Clock Inputs..... | 9-25 |
| 9.4.1 Operating Timer 0 (8-Bit Timer Mode) by External Clock (P04/T02P0CK)..... | 9-25 |
| 9.4.2 Operating Timer 0 (8-Bit Timer Mode) by External Clock (P44/T02P0CK)..... | 9-25 |
| 9.4.3 Operating Timer 1 (8-Bit Timer Mode) by External Clock (P45/T13CK)..... | 9-26 |
| 9.4.4 Operating Timer 2 (8-Bit Timer Mode) by External Clock (P04/T02P0CK)..... | 9-27 |
| 9.4.5 Operating Timer 2 (8-Bit Timer Mode) by External Clock (P44/T02P0CK)..... | 9-27 |
| 9.4.6 Operating Timer 3 (8-Bit Timer Mode) by External Clock (P45/T13CK)..... | 9-28 |
| 9.4.7 Operating Timer 0 and Timer 1 (16-Bit Timer Mode) by External Clock (P04/T02P0CK) | 9-29 |
| 9.4.8 Operating Timer 0 and Timer 1 (16-Bit Timer Mode) by External Clock (P44/T02P0CK) | 9-29 |
| 9.4.9 Operating Timer 2 and Timer 3 (16-Bit Timer Mode) by External Clock (P44/T02P0CK) | 9-30 |

Chapter 10

| | |
|---|------|
| 10. PWM..... | 10-1 |
| 10.1 Overview | 10-1 |
| 10.1.1 Features..... | 10-1 |
| 10.1.2 Configuration..... | 10-1 |
| 10.1.3 List of Pins..... | 10-2 |
| 10.2 Description of Registers..... | 10-3 |
| 10.2.1 List of Registers..... | 10-3 |
| 10.2.2 PWM0 Period Registers (PW0PL, PW0PH) | 10-4 |
| 10.2.3 PWM0 Duty Registers (PW0DL, PW0DH) | 10-5 |
| 10.2.4 PWM0 Counter Registers (PW0CH, PW0CL)..... | 10-6 |
| 10.2.5 PWM0 Control Register 0 (PW0CON0) | 10-7 |

| | |
|--|-------|
| 10.2.6 PWM0 Control Register 1 (PW0CON1) | 10-8 |
| 10.3 Description of Operation | 10-9 |
| 10.4 Specifying port registers | 10-11 |
| 10.4.1 Functioning the P43 pin (PWM0) as the PWM output..... | 10-11 |
| 10.4.2 Functioning the P24 pin (PWM0) as the PWM output..... | 10-12 |
| 10.4.3 Operating PWM0 with External Clock (P04/T02P0CK)..... | 10-13 |
| 10.4.4 Operating PWM0 with External Clock (P44/T02P0CK)..... | 10-14 |

Chapter 11

| | |
|---|------|
| 11. Watchdog Timer..... | 11-1 |
| 11.1 Overview | 11-1 |
| 11.1.1 Features..... | 11-1 |
| 11.1.2 Configuration..... | 11-1 |
| 11.2 Description of Registers | 11-2 |
| 11.2.1 List of Registers..... | 11-2 |
| 11.2.2 Watchdog Timer Control Register (WDTCON)..... | 11-3 |
| 11.2.3 Watchdog Timer Mode Register (WDTMOD)..... | 11-4 |
| 11.3 Description of Operation | 11-5 |
| 11.3.1 Handling example when you do not want to use the watch dog timer | 11-7 |

Chapter 12

| | |
|---|-------|
| 12 Synchronous Serial Port | 12-1 |
| 12.1 Overview | 12-1 |
| 12.1.1 Features..... | 12-1 |
| 12.1.2 Configuration..... | 12-1 |
| 12.1.3 List of Pins..... | 12-2 |
| 12.2 Description of Registers | 12-3 |
| 12.2.1 List of Registers..... | 12-3 |
| 12.2.2 Serial Port 0 Transmit/Receive Buffers (SIO0BUFL and SIO0BUFH)..... | 12-4 |
| 12.2.3 Serial Port 1 Transmit/Receive Buffers (SIO1BUFL and SIO1BUFH)..... | 12-5 |
| 12.2.4 Serial Port 0 Control Register (SIO0CON) | 12-6 |
| 12.2.5 Serial port 1 Control Register (SIO1CON)..... | 12-6 |
| 12.2.6 Serial Port 0 Mode Register 0 (SIO0MOD0) | 12-7 |
| 12.2.7 Serial Port 1 Mode Register 0 (SIO1MOD0) | 12-8 |
| 12.2.8 Serial Port 0 Mode Register 1 (SIO0MOD1) | 12-9 |
| 12.2.9 Serial Port 1 Mode Register 1 (SIO1MOD1) | 12-10 |
| 12.3 Description of Operation | 12-11 |
| 12.3.1 Transmit Operation | 12-11 |
| 12.3.2 Receive Operation | 12-13 |
| 12.3.3 Transmit/Receive Operation | 12-14 |
| 12.4 Specifying port registers..... | 12-16 |
| 12.4.1 Functioning P42 (SOUT0: Output), P41 (SCK0: Input/Output), and P40 (SIN0: Input) as the SSIO0/ "Master mode"..... | 12-16 |
| 12.4.2 Functioning P42 (SOUT0: Output), P41 (SCK0: Input/Output), and P40 (SIN0: Input) as the SSIO0/ "Slave mode" | 12-17 |
| 12.4.3 Functioning P46 (SOUT0: Output), P45 (SCK0: Input/Output) and P44 (SIN0 : Input) as the SSIO0/ "Master mode" | 12-18 |
| 12.4.4 Functioning P46 (SOUT0: Output), P45 (SCK0: Input/Output) and P44 (SIN0 : Input) as the SSIO0/ "Slave mode" | 12-19 |
| 12.4.5 Functioning P52 (SOUT1: Output), P51 (SCK1: Input/Output), and P50 (SIN1: Input) as the SSIO1/ "Master mode"..... | 12-20 |
| 12.4.6 Functioning P52 (SOUT1: Output), P51 (SCK1: Input/Output), and P50 (SIN1: Input) as the SSIO1/ "Slave mode" | 12-21 |

| | |
|---|-------|
| 12.4.7 Functioning P56 (SOUT1: Output), P55 (SCK1: Input/Output), and P54 (SIN1: Input) as the SSIO1/ "Master mode" | 12-22 |
| 12.4.8 Functioning P56 (SOUT1: Output), P55 (SCK1: Input/Output), and P54 (SIN1: Input) as the SSIO1/ "Slave mode" | 12-23 |

Chapter 13

| | |
|--|-------|
| 13. UART | 13-1 |
| 13.1 Overview | 13-1 |
| 13.1.1 Features | 13-1 |
| 13.1.2 Configuration | 13-1 |
| 13.1.3 List of Pins | 13-2 |
| 13.2 Description of Registers | 13-3 |
| 13.2.1 List of Registers | 13-3 |
| 13.2.2 UART0 Transmit/Receive Buffer (UA0BUF) | 13-4 |
| 13.2.3 UART0 Control Register (UA0CON) | 13-5 |
| 13.2.4 UART0 Mode Register 0 (UA0MOD0) | 13-6 |
| 13.2.5 UART0 Mode Register 1 (UA0MOD1) | 13-7 |
| 13.2.6 UART0 Baud Rate Registers L, H (UA0BRTL, UA0BRTH) | 13-9 |
| 13.2.7 UART0 Status Register (UA0STAT) | 13-10 |
| 13.3 Description of Operation | 13-12 |
| 13.3.1 Transfer Data Format | 13-12 |
| 13.3.2 Baud rate | 13-13 |
| 13.3.3 Transmitted Data Direction | 13-14 |
| 13.3.4 Transmit Operation | 13-15 |
| 13.3.5 Receive Operation | 13-17 |
| 13.3.5.1 Detection of Start Bit | 13-19 |
| 13.3.5.2 Sampling Timing | 13-19 |
| 13.3.5.3 Receive Margin | 13-20 |
| 13.4 Specifying port registers | 13-21 |
| 13.4.1 Functioning P43(TXD0) and P42(RXD0) as the UART | 13-21 |
| 13.4.2 Functioning P43(TXD0) and P02(RXD0) as the UART | 13-22 |

Chapter 14

| | |
|---|------|
| 14. Port 0 | 14-1 |
| 14.1 Overview | 14-1 |
| 14.1.1 Features | 14-1 |
| 14.1.2 Configuration | 14-1 |
| 14.1.3 List of Pins | 14-1 |
| 14.2 Description of Registers | 14-2 |
| 14.2.1 List of Registers | 14-2 |
| 14.2.2 Port 0 Data Register (P0D) | 14-3 |
| 14.2.3 Port 0 Control Registers 0, 1 (P0CON0, P0CON1) | 14-4 |
| 14.2.4 External Interrupt Control Registers 0, 1 (EXICON0, EXICON1) | 14-5 |
| 14.2.5 External Interrupt Control Register 2 (EXICON2) | 14-6 |
| 14.3 Description of Operation | 14-7 |
| 14.3.1 External Interrupt / Secondary Function | 14-7 |
| 14.3.2 Interrupt Request | 14-7 |

Chapter 15

| | |
|------------------|------|
| 15. Port 2 | 15-1 |
|------------------|------|

| | |
|--|------|
| 15.1 Overview..... | 15-1 |
| 15.1.1 Features..... | 15-1 |
| 15.1.2 Configuration..... | 15-1 |
| 15.1.3 List of Pins..... | 15-1 |
| 15.2 Description of Registers | 15-2 |
| 15.2.1 List of Registers..... | 15-2 |
| 15.2.2 Port 2 Data Register (P2D)..... | 15-3 |
| 15.2.3 Port 2 Control Registers 0, 1 (P2CON0, P2CON1)..... | 15-4 |
| 15.2.4 Port 2 Mode Register (P2MOD)..... | 15-5 |
| 15.3 Description of Operation | 15-6 |
| 15.3.1 Output Port Function | 15-6 |
| 15.3.2 Secondary Function | 15-6 |

Chapter 16

| | |
|--|------|
| 16. Port 3 | 16-1 |
| 16.1 Overview..... | 16-1 |
| 16.1.1 Features..... | 16-1 |
| 16.1.2 Configuration..... | 16-1 |
| 16.1.3 List of Pins..... | 16-1 |
| 16.2 Description of Registers | 16-2 |
| 16.2.1 List of Registers..... | 16-2 |
| 16.2.2 Port 3 Data register (P3D) | 16-3 |
| 16.2.3 Port 3 Direction Register (P3DIR)..... | 16-4 |
| 16.2.4 Port 3 Control Registers 0, 1 (P3CON0, P3CON1)..... | 16-5 |
| 16.2.5 Port 3 Mode Register 0 (P3MOD0)..... | 16-7 |
| 16.3 Description of Operation | 16-9 |
| 16.3.1 Input/Output Port Functions | 16-9 |
| 16.3.2 Secondary Function | 16-9 |

Chapter 17

| | |
|--|-------|
| 17. Port 4 | 17-1 |
| 17.1 Overview..... | 17-1 |
| 17.1.1 Features..... | 17-1 |
| 17.1.2 Configuration..... | 17-1 |
| 17.1.3 List of Pins..... | 17-2 |
| 17.2 Description of Registers | 17-3 |
| 17.2.1 List of Registers..... | 17-3 |
| 17.2.2 Port 4 Data Register (P4D)..... | 17-4 |
| 17.2.3 Port 4 Direction Register (P4DIR)..... | 17-5 |
| 17.2.4 Port 4 Control Registers 0, 1 (P4CON0, P4CON1)..... | 17-6 |
| 17.2.5 Port 4 Mode Registers 0, 1 (P4MOD0, P4MOD1)..... | 17-8 |
| 17.3 Description of Operation | 17-11 |
| 17.3.1 Input/Output Port Functions | 17-11 |
| 17.3.2 Secondary and tertiary functions | 17-11 |

Chapter 18

| | |
|-------------------------------------|------|
| 18. Port 5 | 18-1 |
| 18.1 Overview | 18-1 |
| 18.1.1 Features..... | 18-1 |
| 18.1.2 Configuration..... | 18-1 |
| 18.1.3 List of Pins..... | 18-2 |
| 18.2 Description of Registers | 18-3 |

| | | |
|--------|--|-------|
| 18.2.1 | List of Registers | 18-3 |
| 18.2.2 | Port 5 Data Register (P5D) | 18-4 |
| 18.2.3 | Port 5 Direction Register (P5DIR) | 18-5 |
| 18.2.4 | Port 5 Control Registers 0 and 1 (P5CON0 and P5CON1) | 18-6 |
| 18.2.5 | Port 5 Mode Register 0 and 1 (P5MOD0 and P5MOD1) | 18-8 |
| 18.2.6 | Port 5 Interrupt mode Register (P5ISEL) | 18-10 |
| 18.3 | Description of Operation | 18-11 |
| 18.3.1 | Input/Output Port Functions | 18-11 |
| 18.3.2 | Secondary and tertiary Functions | 18-11 |
| 18.3.3 | External Interrupt | 18-11 |
| 18.3.4 | Interrupt Request | 18-12 |

Chapter 19

| | | |
|--------|--|------|
| 19. | Port 6 | 19-1 |
| 19.1 | Overview | 19-1 |
| 19.1.1 | Features | 19-1 |
| 19.1.2 | Configuration | 19-1 |
| 19.1.3 | List of Pins | 19-1 |
| 19.2 | Description of Registers | 19-2 |
| 19.2.1 | List of Registers | 19-2 |
| 19.2.2 | Port 6 Data Register (P6D) | 19-3 |
| 19.2.3 | Port 6 Control Register 0 (P6CON0) | 19-4 |
| 19.3 | Description of Operation | 19-5 |
| 19.3.1 | Output Port Function | 19-5 |

Chapter 20

| | | |
|--------|--|-------|
| 20. | Melody Driver | 20-1 |
| 20.1 | Overview | 20-1 |
| 20.1.1 | Features | 20-1 |
| 20.1.2 | Configuration | 20-1 |
| 20.1.3 | List of Pins | 20-1 |
| 20.2 | Description of Registers | 20-2 |
| 20.2.1 | List of Registers | 20-2 |
| 20.2.2 | Melody 0 Control Register (MD0CON) | 20-3 |
| 20.2.3 | Melody 0 Tempo Code Register (MD0TMP) | 20-4 |
| 20.2.4 | Melody 0 Scale Code Register (MD0TON) | 20-5 |
| 20.2.5 | Melody 0 Tone Length Code Register (MD0LEN) | 20-6 |
| 20.3 | Description of Operation | 20-7 |
| 20.3.1 | Operation of Melody Output | 20-7 |
| 20.3.2 | Tempo Codes | 20-8 |
| 20.3.3 | Tone Length Codes | 20-9 |
| 20.3.4 | Scale Codes | 20-10 |
| 20.3.5 | Example of Using Melody Circuit | 20-11 |
| 20.3.6 | Operations of Buzzer Output | 20-12 |
| 20.4 | Specifying Port Registers | 20-13 |
| 20.4.1 | Functioning P22 Pin (MD0: Output) as the Melody or Buzzer Output | 20-13 |
| 20.4.2 | Functioning P50 Pin (MD0: Output) as the Melody or Buzzer Output | 20-14 |

Chapter 21

| | | |
|--------|---|------|
| 21. | RC Oscillation Type A/D Converter | 21-1 |
| 21.1 | Overview | 21-1 |
| 21.1.1 | Features | 21-1 |

| | |
|---|-------|
| 21.1.2 Configuration | 21-1 |
| 21.1.3 List of Pins | 21-2 |
| 21.2 Description of Registers | 21-3 |
| 21.2.1 List of Registers | 21-3 |
| 21.2.2 RC-ADC Counter A Registers (RADCA0–1)..... | 21-4 |
| 21.2.3 RC-ADC Counter B Registers (RADCB0–1)..... | 21-5 |
| 21.2.4 RC-ADC Mode Register (RADMOD) | 21-6 |
| 21.2.5 RC-ADC Control Register (RADCON) | 21-7 |
| 21.3 Description of Operation | 21-8 |
| 21.3.1 RC Oscillator Circuits..... | 21-8 |
| 21.3.2 Counter A/Counter B Reference Modes | 21-11 |
| 21.3.3 Example of Use of RC Oscillation Type A/D Converter | 21-14 |
| 21.3.4 Monitoring RC Oscillation | 21-18 |
| 21.4 Specifying Port Registers | 21-19 |
| 21.4.1 Functioning P35(RCM), P34(RCT0), P33(RT0), P32(RS0), P31(CS0) and P30(IN0) as the RC-ADC(Ch0)..... | 21-19 |
| 21.4.2 Functioning P47(RT1), P46(RS1), P45(CS1) and P44(IN1) as the RC-ADC(Ch1) | 21-20 |

Chapter 22

| | |
|---|-------|
| 22. LCD Driver..... | 22-1 |
| 22.1 Overview | 22-1 |
| 22.1.1 Features..... | 22-3 |
| 22.1.2 Configuration of the LCD Drivers..... | 22-3 |
| 22.1.3 Configuration of the Bias Generation Circuit..... | 22-4 |
| 22.1.4 List of Pins..... | 22-6 |
| 22.2 Description of Registers | 22-8 |
| 22.2.1 List of Registers | 22-8 |
| 22.2.2 Bias Circuit Control Register 0 (BIASCON) | 22-9 |
| 22.2.3 Display Mode Register 0 (DSPMOD0)..... | 22-10 |
| 22.2.4 Display Mode Register 1 (DSPMOD1)..... | 22-11 |
| 22.2.5 Display Control Register (DSPCON)..... | 22-12 |
| 22.2.6 Display Allocation Register A (DS0C0A to DS39C4A)..... | 22-13 |
| 22.2.7 Display Allocation Register B (DS39C4B to DS49C7B)..... | 22-15 |
| 22.2.8 Display Registers (DSPR00 to DSPR27) | 22-17 |
| 22.3 Description of Operation | 22-19 |
| 22.3.1 Operation of LCD Drivers and Bias Generation Circuit | 22-19 |
| 22.3.2 Segment Mapping When the Programmable Display Allocation Function is Not Used..... | 22-20 |
| 22.3.3 Segment Mapping When the Programmable Display Allocation Function is Used..... | 22-21 |
| 22.3.4 Common Output Waveforms..... | 22-22 |
| 22.3.5 Segment Output Waveform | 22-24 |

Chapter 23

| | |
|-------------------------------|------|
| 23. Power Supply Circuit..... | 23-1 |
| 23.1 Overview..... | 23-1 |
| 23.1.1 Features..... | 23-1 |
| 23.1.2 Configuration..... | 23-1 |
| 23.1.3 List of Pins..... | 23-1 |

Chapter 24

| | |
|-----------------------|------|
| 24. Mask Option | 24-1 |
| 24.1 Overview | 24-1 |
| 24.2 Features..... | 24-1 |

Appendixes

| | | |
|------------|-----------------------------------|-----|
| Appendix A | Registers | A-1 |
| Appendix B | Package Dimensions | B-1 |
| Appendix C | Electrical Characteristics | C-1 |
| Appendix D | Application Circuit Example | D-1 |
| Appendix E | Check List..... | E-1 |

Chapter 1

Overview

1. Overview

1.1 Features

This LSI is a high performance CMOS 8-bit microcontroller equipped with an 8-bit CPU nX-U8/100 and integrated with peripheral functions such as the synchronous serial port, UART, melody driver, RC oscillation type A/D converter, and LCD driver.

The CPU nX-U8/100 is capable of efficient instruction execution in 1-instruction 1-clock mode by 3-stage pipe line architecture parallel processing. Additionally, it adopts the low-/high-speed dual clock system, standby mode, and process that prohibits leak current at high temperatures, and is most suitable for battery-driven applications.

For industrial use, ML610407P/ML610408P/ML610409P with the extended operating ambient temperature ranging from -40°C to 85°C are available.

- CPU
 - 8-bit RISC CPU (CPU name: nX-U8/100)
 - Instruction system: 16-bit length instruction
 - Instruction set: Transfer, arithmetic operations, comparison, logic operations, multiplication/division, bit manipulations, bit logic operations, jump, conditional jump, call return stack manipulations, arithmetic shift, and so on
 - Minimum instruction execution time
 - 30.5 μ s (at 32.768 kHz system clock)
 - 2 μ s (at 500 kHz system clock)
 - 0.5 μ s (at 2 MHz system clock)

- Internal memory
 - Internal 16KByte maskROM (8K x 16 bits) (including unusable 1KByte TEST area)
 - Internal 1KByte RAM (1024 x 8 bits)

- Interrupt controller
 - 1 non-maskable interrupt source:
 - Internal source: 1 (Watchdog Timer)
 - 27 maskable interrupt sources:
 - Internal source: 14 (Synchronous serial port 0, Synchronous serial port 1, Timer 0, Timer 1, Timer 2, Timer 3, UART0, Melody 0, RC Oscillation type A/D converter, PWM0, TBC128Hz, TBC32Hz, TBC16Hz, TBC2Hz)
 - External source: 13 (P00, P01, P02, P03, P04, P50, P51, P52, P53, P54, P55, P56, P57) *

*: For P50 to P57, the interrupt sources are ORed into a single interrupt request.

- Time base counter
 - Low-speed time base counter x 1 channel
 - Frequency compensation (Compensation range: Approx. -488ppm to +488ppm. Compensation accuracy: Approx. 0.48ppm)
 - High-speed time base counter x 1 channel

- Watchdog timer
 - Non-maskable interrupt and reset
 - Free running
 - Overflow period: 4 types selectable (125ms, 500ms, 2s, 8s)

- Timer
 - 8 bits x 4 channels [also available is 16-bit configuration (using Timers 0 and 1, or Timers 2 and 3) x 2 channels]
 - Clock frequency measurement function mode (16-bit configuration using Timers 2 and 3 x 1 channel only)
- Capture
 - Time base capture x 2 channels (4096 Hz to 32 Hz)
- PWM
 - Resolution 16 bits x 1 channel
- Synchronous serial port
 - Master/slave selectable x 2 channels
 - LSB first/MSB first selectable
 - 8-bit length/16-bit length selectable
- UART
 - TXD/RXD × 1 channel
 - Bit length, parity/no parity, odd parity/even parity, 1 stop bit/2 stop bits
 - Positive logic/negative logic selectable
 - Built-in baud rate generator
- Melody driver
 - Scale: 29 types (Melody sound frequency: 508 Hz to 32.768 kHz)
 - Tone length: 63 types
 - Tempo: 15 types
 - Buzzer output mode (4 output modes, 8 frequencies, 16 duty levels)
- RC oscillation type A/D converter
 - 16-bit counter
 - Time division x 2 channels
- General-purpose port
 - Input-only port: 5 channels (including secondary functions)
 - Output-only port
 - ML610407: 12 channels (including secondary functions)
 - ML610408: 8 channels (including secondary functions)
 - ML610409: 4 channels (including secondary functions)
 - Input/output port: 22 channels (including secondary functions)
- LCD driver
 - Number of segments
 - ML610407: Up to 145 dots (select among 29 segments x 5 commons, 30 segments x 4 commons, 31 segments x 3 commons, and 32 segments x 2 commons)
 - ML610408: Up to 165 dots (select among 33 segments x 5 commons, 34 segments x 4 commons, 35 segments x 3 commons, and 36 segments x 2 commons)
 - ML610409: Up to 185 dots (select among 37 segments x 5 commons, 38 segments x 4 commons, 39 segments x 3 commons, and 40 segments x 2 commons)
 - 1/1 to 1/5 duty
 - 1/2 or 1/3 bias (built-in bias generation circuit)
 - Frame frequency selectable (approx. 64 Hz, 73 Hz, 85 Hz, and 102 Hz)
 - Bias voltage multiplying clock selectable (8 types)
 - LCD drive stop mode, LCD display mode, all LCDs on mode, and all LCDs off mode selectable
 - Programmable display allocation function
- Reset
 - Reset through the RESET_N pin
 - Power-on reset generation when powered on
 - Reset when oscillation stop of the low-speed clock is detected (Cancellation by a mask option is possible)
 - Reset by the watchdog timer (WDT) overflow

- Clock
 - Low-speed clock (Operation of this LSI is not guaranteed under a condition with no supply of low-speed crystal oscillation clock)
Crystal oscillation (32.768 kHz)
 - High-speed clock
Built-in RC oscillation (500 kHz/2 MHz selectable by software)

- Power management
 - HALT mode: Suspends the instruction execution by CPU (peripheral circuits are in operating states)
 - STOP mode: Stops the low-speed oscillation and high-speed oscillation (Operations of CPU and peripheral circuits are stopped.)
 - High-speed clock gear: The frequency of high-speed system clock can be changed by software (1/1, 1/2, 1/4, or 1/8 of the oscillation clock)
 - Block control function: Completely stops the operation of any function block circuit that is not used (resets registers and stops clock)

- Shipment
 - Chip (Die)
 - ML610407-xxxWA
 - ML610408-xxxWA
 - ML610409-xxxWA
 - ML610407P-xxxWA
 - ML610408P-xxxWA
 - ML610409P-xxxWA
 - 100-pin plastic TQFP
 - ML610407-xxxTBZ0AAL
 - ML610408-xxxTBZ0AAL
 - ML610409-xxxTBZ0AAL
 - ML610407P-xxxTBZ0AAL
 - ML610408P-xxxTBZ0AAL
 - ML610409P-xxxTBZ0AAL

xxx: ROM code number (xxx of the blank product is NNN)
Q: MTP version
P: Wide range temperature version (P version)
WA: Chip (Die)
TBZ0AAL: TQFP

- Guaranteed Operation Range
 - Operating temperature: -20°C to +70°C (P version: -40°C to +85°C)
 - Operating voltage: $V_{DD} = 1.25V$ to 3.6V

1.2 Configuration of Functional Blocks

1.2.1 Block Diagram of ML610407/ML610408/ML610409

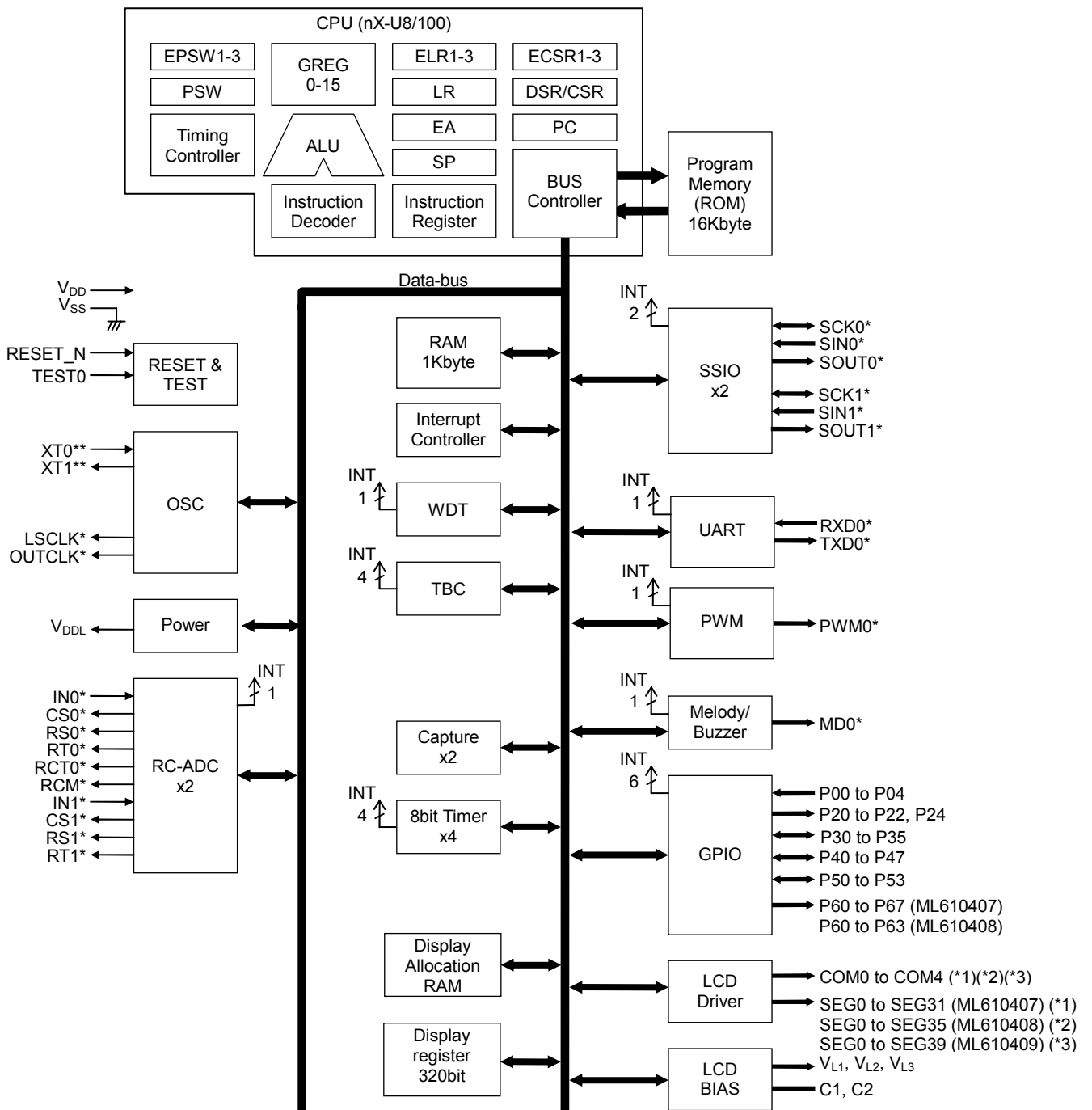

* Secondary function or Tertiary function

“*1”: Select among 29 segments x 5 commons, 30 segments x 4 commons, 31 segments x 3 commons, and 32 segments x 2 commons with the register

“*2”: Select among 33 segments x 5 commons, 34 segments x 4 commons, 35 segments x 3 commons, and 36 segments x 2 commons with the register

“*3”: Select among 37 segments x 5 commons, 38 segments x 4 commons, 39 segments x 3 commons, and 40 segments x 2 commons with the register

Figure 1-1 Block Diagram of ML610407/ML610408/ML610409

1.3 Pins

1.3.1 Pin Layout

1.3.1.1 Pin Layout of ML610407 TQFP Package

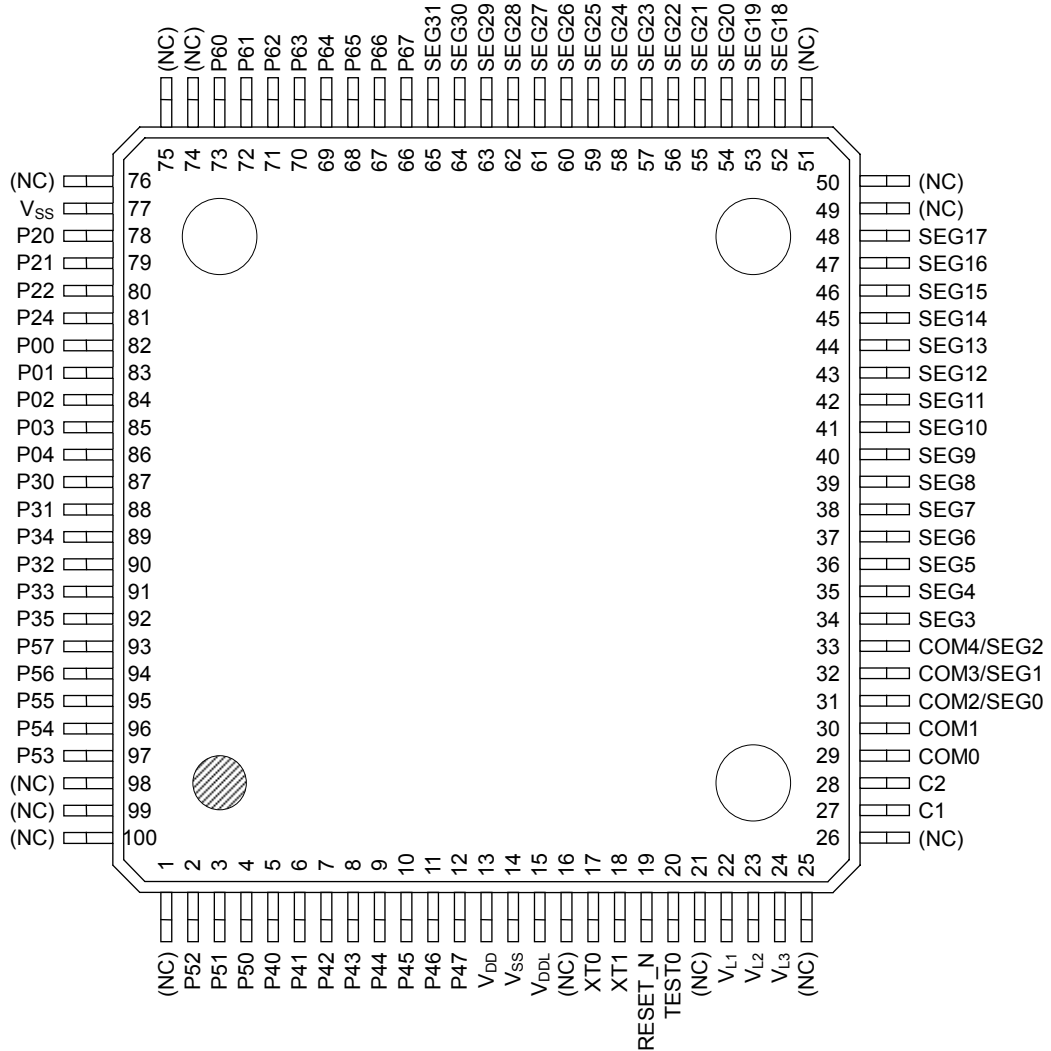

(NC): No Connection

Note:

The assignment of the pads P30 to P35 are not in order.

Figure 1-2 Pin Layout of ML610407 Package

1.3.1.2 Pin Layout of ML610408 TQFP Package

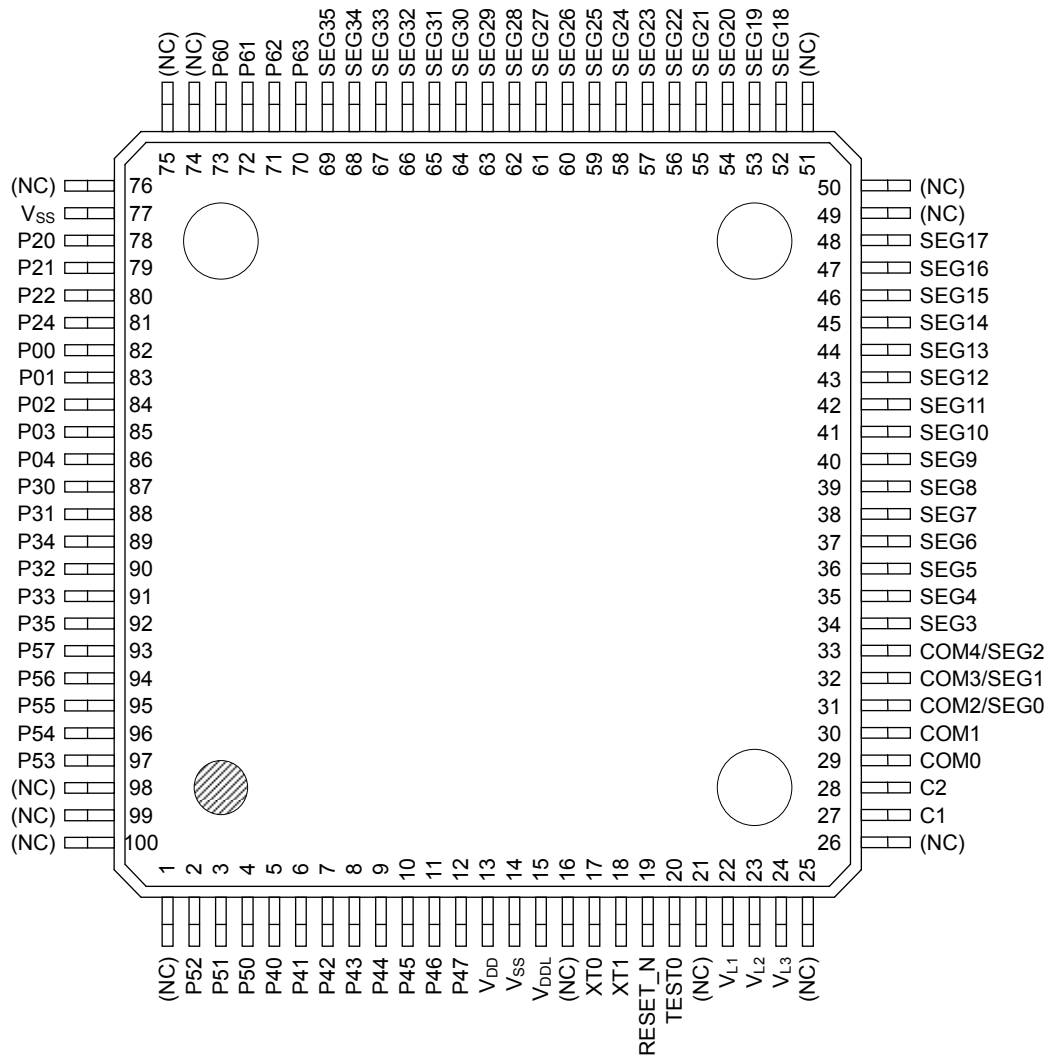

(NC): No Connection

Note:

The assignment of the pads P30 to P35 are not in order.

Figure 1-3 Pin Layout of ML610408 Package

1.3.1.3 Pin Layout of ML610409 TQFP Package

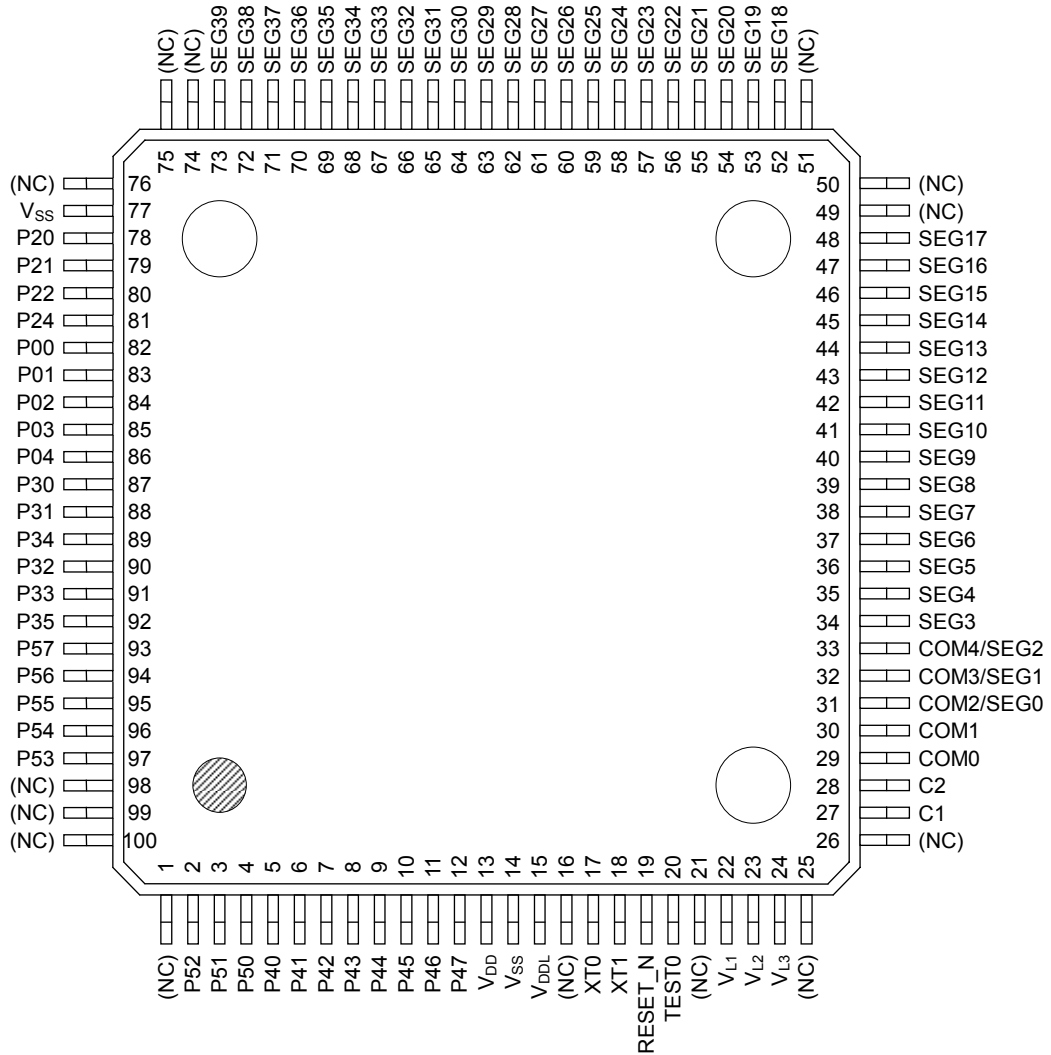

(NC): No Connection

Note:

The assignment of the pads P30 to P35 are not in order.

Figure 1-4 Pin Layout of ML610409 Package

1.3.1.4 Pin Layout of ML610407 Chip

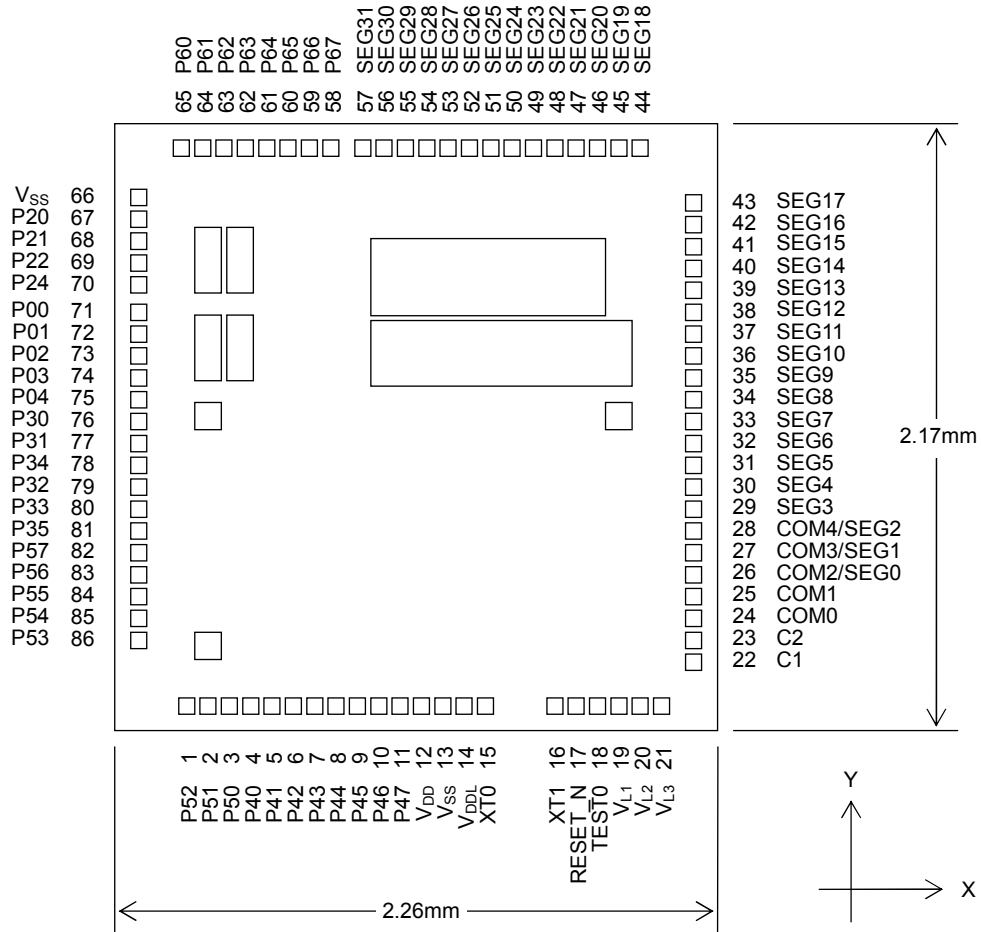

Note:
 The assignment of the pads P30 to P35 are not in order.

- Chip size: 2.26 mm × 2.17 mm
- PAD count: 86 pins
- Minimum PAD pitch: 80μm
- PAD aperture: 70μm×70μm
- Chip thickness: 350μm
- Voltage of the rear side of chip: V_{SS} level.

Figure 1-5 Dimensions of ML610407 Chip

1.3.1.5 Pin Layout of ML610408 Chip

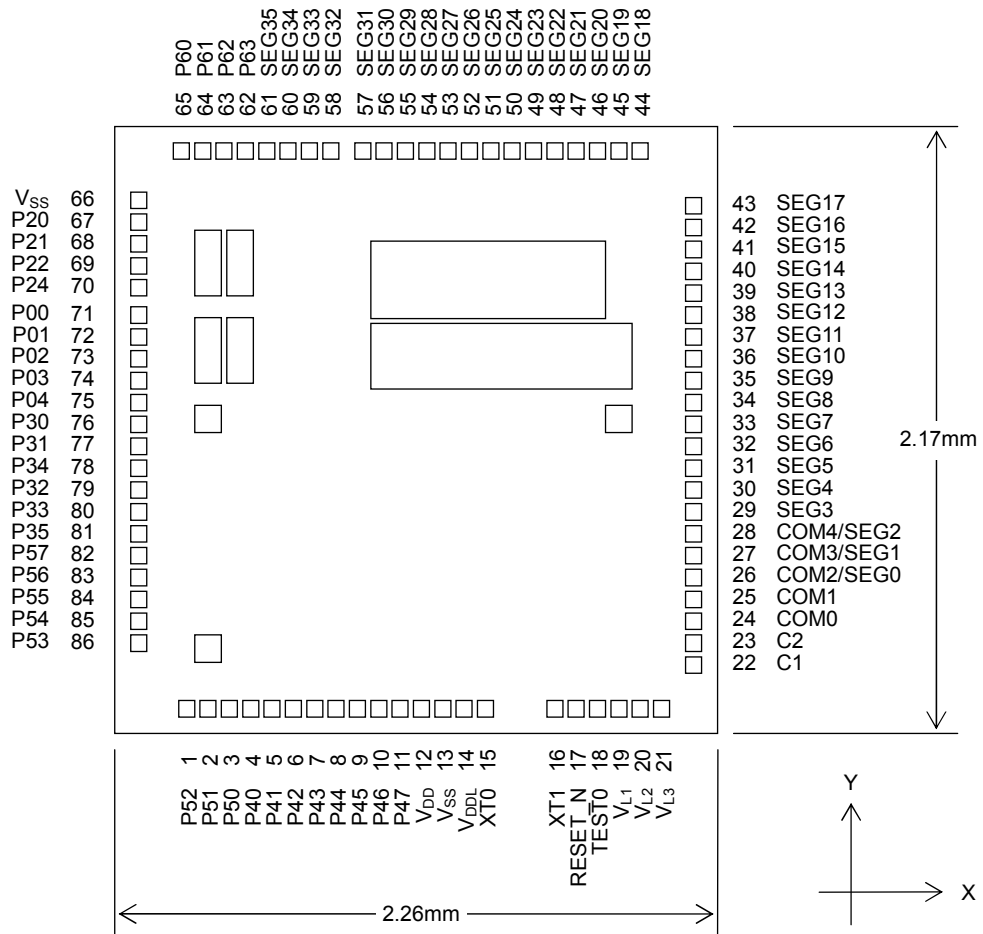

Note:
The assignment of the pads P30 to P35 are not in order.

- Chip size: 2.26 mm × 2.17 mm
- PAD count: 86 pins
- Minimum PAD pitch: 80μm
- PAD aperture: 70μm×70μm
- Chip thickness: 350μm
- Voltage of the rear side of chip: V_{SS} level.

Figure 1-6 Dimensions of ML610408 Chip

1.3.1.6 Pin Layout of ML610409 Chip

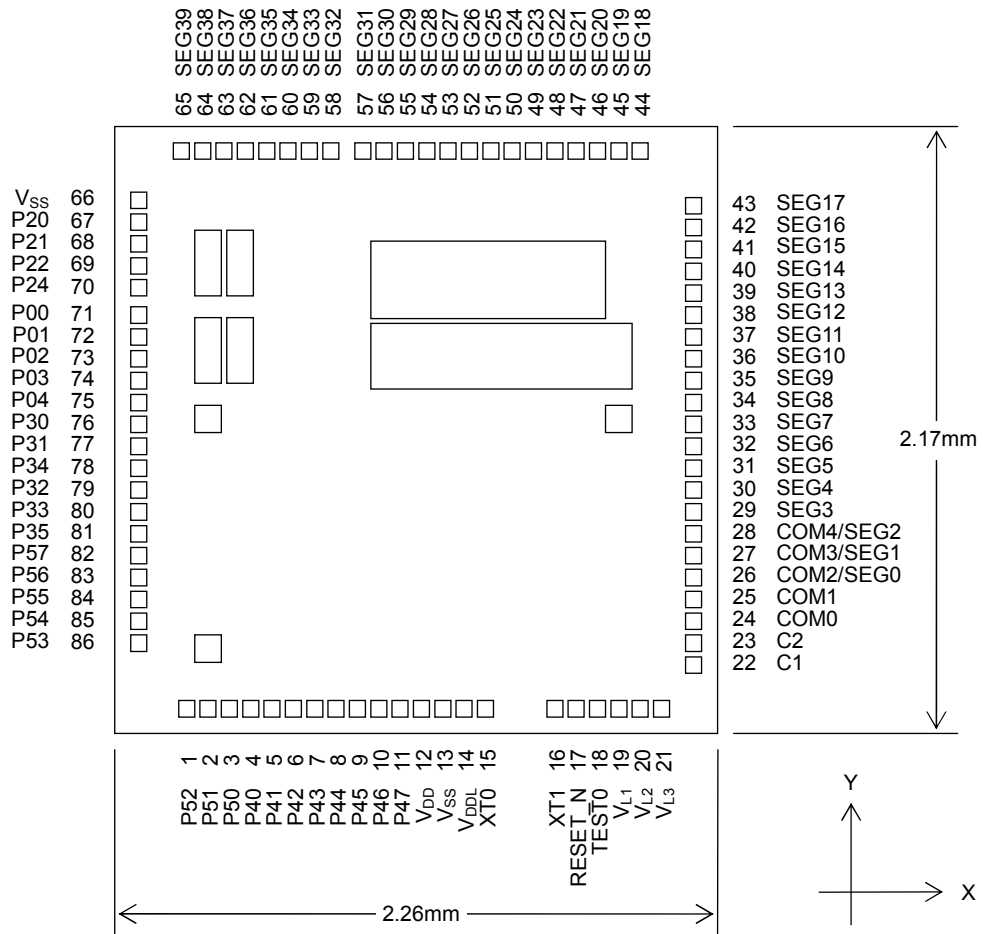

Note:
 The assignment of the pads P30 to P35 are not in order.

- Chip size: 2.26 mm × 2.17 mm
- PAD count: 86 pins
- Minimum PAD pitch: 80 μm
- PAD aperture: 70 μm×70 μm
- Chip thickness: 350 μm
- Voltage of the rear side of chip: V_{SS} level.

Figure 1-7 Dimensions of ML610409 Chip

1.3.1.7 Pad Coordinates of ML610407/ML610408/ML610409 Chip

Table 1-1 Pad Coordinates of ML610407/ML610408/ML610409

Chip Center: X=0,Y=0

| PAD No. | Pad Name | ML610407/8/9 | | PAD No. | Pad Name | ML610407/8/9 | |
|---------|------------------|--------------|--------|---------|----------------------------|--------------|--------|
| | | X (μm) | Y (μm) | | | X (μm) | Y (μm) |
| 1 | P52 | -853 | -979 | 48 | SEG22 | 520 | 979 |
| 2 | P51 | -773 | -979 | 49 | SEG23 | 440 | 979 |
| 3 | P50 | -693 | -979 | 50 | SEG24 | 360 | 979 |
| 4 | P40 | -613 | -979 | 51 | SEG25 | 280 | 979 |
| 5 | P41 | -533 | -979 | 52 | SEG26 | 200 | 979 |
| 6 | P42 | -453 | -979 | 53 | SEG27 | 120 | 979 |
| 7 | P43 | -373 | -979 | 54 | SEG28 | 40 | 979 |
| 8 | P44 | -293 | -979 | 55 | SEG29 | -40 | 979 |
| 9 | P45 | -213 | -979 | 56 | SEG30 | -120 | 979 |
| 10 | P46 | -133 | -979 | 57 | SEG31 | -200 | 979 |
| 11 | P47 | -53 | -979 | 58 | P67 ^{(*)1} | -295 | 979 |
| 12 | V _{DD} | 27 | -979 | | SEG32 ^{(*)2} (*)3 | | |
| 13 | V _{SS} | 107 | -979 | 59 | P66 ^{(*)1} | -375 | 979 |
| 14 | V _{DDL} | 187 | -979 | | SEG33 ^{(*)2} (*)3 | | |
| 15 | XT0 | 267 | -979 | 60 | P65 ^{(*)1} | -455 | 979 |
| 16 | XT1 | 427 | -979 | | SEG34 ^{(*)2} (*)3 | | |
| 17 | RESET_N | 507 | -979 | 61 | P64 ^{(*)1} | -535 | 979 |
| 18 | TEST0 | 587 | -979 | | SEG35 ^{(*)2} (*)3 | | |
| 19 | V _{L1} | 667 | -979 | 62 | P63 ^{(*)1} (*)2 | -615 | 979 |
| 20 | V _{L2} | 747 | -979 | | SEG36 ^{(*)3} | | |
| 21 | V _{L3} | 827 | -979 | 63 | P62 ^{(*)1} (*)2 | -695 | 979 |
| 22 | C1 | 1024 | -845 | | SEG37 ^{(*)3} | | |
| 23 | C2 | 1024 | -765 | 64 | P61 ^{(*)1} (*)2 | -775 | 979 |
| 24 | COM0 | 1024 | -685 | | SEG38 ^{(*)3} | | |
| 25 | COM1 | 1024 | -605 | 65 | P60 ^{(*)1} (*)2 | -855 | 979 |
| 26 | COM2/SEG0 | 1024 | -525 | | SEG39 ^{(*)3} | | |
| 27 | COM3/SEG1 | 1024 | -445 | 66 | V _{SS} | -1024 | 842 |
| 28 | COM4/SEG2 | 1024 | -365 | 67 | P20 | -1024 | 762 |
| 29 | SEG3 | 1024 | -285 | 68 | P21 | -1024 | 682 |
| 30 | SEG4 | 1024 | -205 | 69 | P22 | -1024 | 602 |
| 31 | SEG5 | 1024 | -125 | 70 | P24 | -1024 | 522 |
| 32 | SEG6 | 1024 | -45 | 71 | P00 | -1024 | 422 |
| 33 | SEG7 | 1024 | 35 | 72 | P01 | -1024 | 342 |
| 34 | SEG8 | 1024 | 115 | 73 | P02 | -1024 | 262 |
| 35 | SEG9 | 1024 | 195 | 74 | P03 | -1024 | 182 |
| 36 | SEG10 | 1024 | 275 | 75 | P04 | -1024 | 102 |
| 37 | SEG11 | 1024 | 355 | 76 | P30 | -1024 | 22 |
| 38 | SEG12 | 1024 | 435 | 77 | P31 | -1024 | -58 |
| 39 | SEG13 | 1024 | 515 | 78 | P34 | -1024 | -138 |
| 40 | SEG14 | 1024 | 595 | 79 | P32 | -1024 | -218 |
| 41 | SEG15 | 1024 | 675 | 80 | P33 | -1024 | -298 |
| 42 | SEG16 | 1024 | 755 | 81 | P35 | -1024 | -378 |
| 43 | SEG17 | 1024 | 835 | 82 | P57 | -1024 | -458 |
| 44 | SEG18 | 840 | 979 | 83 | P56 | -1024 | -538 |
| 45 | SEG19 | 760 | 979 | 84 | P55 | -1024 | -618 |
| 46 | SEG20 | 680 | 979 | 85 | P54 | -1024 | -698 |
| 47 | SEG21 | 600 | 979 | 86 | P53 | -1024 | -778 |

(*)1 Pad for ML610407. (*)2 Pad for ML610408. (*)3 Pad for ML610409.

1.3.2 List of Pins

| PIN No. | PAD No. | Primary function | | | Secondary function or Tertiary function | | | |
|---------|---------|----------------------|-----|---|---|----------|-----|---|
| | | Pin name | I/O | Function | Secondary/ Tertiary | Pin name | I/O | Function |
| 14,77 | 13,66 | V _{SS} | — | Negative power supply pin | — | — | — | — |
| 13 | 12 | V _{DD} | — | Positive power supply pin | — | — | — | — |
| 15 | 14 | V _{DDL} | — | Power supply pin for internal logic (internally generated) | — | — | — | — |
| 22 | 19 | V _{L1} | — | Power supply pin for LCD bias (internally generated or connected to positive power supply pin) ^(*) | — | — | — | — |
| 23 | 20 | V _{L2} | — | Power supply pin for LCD bias (internally generated or connected to positive power supply pin) ^(*) | — | — | — | — |
| 24 | 21 | V _{L3} | — | Power supply pin for LCD bias (internally generated) | — | — | — | — |
| 27 | 22 | C1 | — | Capacitor connection pin for LCD bias generation | — | — | — | — |
| 28 | 23 | C2 | — | Capacitor connection pin for LCD bias generation | — | — | — | — |
| 20 | 18 | TEST0 | I/O | Test pin | — | — | — | — |
| 19 | 17 | RESET_N | I | Reset input pin | — | — | — | — |
| 17 | 15 | XT0 | I | Low-speed clock oscillation pin | — | — | — | — |
| 18 | 16 | XT1 | O | Low-speed clock oscillation pin | — | — | — | — |
| 82 | 71 | P00/EXI0/ CAP0 | I | Input port, External interrupt, Capture 0 input | — | — | — | — |
| 83 | 72 | P01/EXI1/ CAP1 | I | Input port, External interrupt, Capture 1 input | — | — | — | — |
| 84 | 73 | P02/EXI2/ RXD0 | I | Input port, External interrupt, UART0 received data | — | — | — | — |
| 85 | 74 | P03/EXI3 | I | Input port, External interrupt | — | — | — | — |
| 86 | 75 | P04/EXI4/ T02P0CK | I | Input port, Timer 0/Timer 2/PWM0 external clock input External interrupt | — | — | — | — |
| 78 | 67 | P20/LED0 | O | Output port | Secondary | LSCLK | O | Low-speed clock output |
| 79 | 68 | P21/LED1 | O | Output port | Secondary | OUTCLK | O | High-speed clock output |
| 80 | 69 | P22/LED2 | O | Output port | Secondary | MD0 | O | Melody 0 output |
| 81 | 70 | P24/LED4 | O | Output port | Secondary | PWM0 | O | PWM0 output |
| 87 | 76 | P30 | I/O | Input/output port | Secondary | IN0 | I | RC type ADC0 oscillation input pin |
| 88 | 77 | P31 | I/O | Input/output port | Secondary | CS0 | O | RC type ADC0 reference capacitor connection pin |
| 89 | 78 | P34 | I/O | Input/output port | Secondary | RCT0 | O | RC type ADC0 resistor/capacitor sensor connection pin |
| 90 | 79 | P32 | I/O | Input/output port | Secondary | RS0 | O | RC type ADC0 reference resistor connection pin |
| 91 | 80 | P33 | I/O | Input/output port | Secondary | RT0 | O | RC type ADC0 measurement resistor sensor connection pin |
| 92 | 81 | P35 | I/O | Input/output port | Secondary | RCM | O | RC type ADC oscillation monitor |

| PIN No. | PAD No. | Primary function | | | Secondary function or Tertiary function | | | |
|---------|---------|------------------|-----|--|---|----------|-----|--|
| | | Pin name | I/O | Function | Secondary /Tertiary | Pin name | I/O | Function |
| 5 | 4 | P40 | I/O | Input/output port | Secondary | — | — | — |
| | | | | | Tertiary | SIN0 | I | SSIO0 data input |
| 6 | 5 | P41 | I/O | Input/output port | Secondary | — | — | — |
| | | | | | Tertiary | SCK0 | I/O | SSIO0 synchronous clock input/output |
| 7 | 6 | P42 | I/O | Input/output port | Secondary | RXD0 | I | UART data input |
| | | | | | Tertiary | SOUT0 | O | SSIO0 data output |
| 8 | 7 | P43 | I/O | Input/output port | Secondary | TXD0 | O | UART data output |
| | | | | | Tertiary | PWM0 | O | PWM0 output |
| 9 | 8 | P44/ T02P0CK | I/O | Input/output port, Timer 0/Timer 2/PWM0 external clock input | Secondary | IN1 | I | RC type ADC1 oscillation input pin |
| | | | | | Tertiary | SIN0 | I | SSIO0 data input |
| 10 | 9 | P45/T13CK | I/O | Input/output port, Timer 1/Timer 3 external clock input | Secondary | CS1 | O | RC type ADC1 reference capacitor connection pin |
| | | | | | Tertiary | SCK0 | I/O | SSIO0 synchronous clock input/output |
| 11 | 10 | P46 | I/O | Input/output port | Secondary | RS1 | O | RC type ADC1 reference resistor connection pin |
| | | | | | Tertiary | SOUT0 | O | SSIO0 data output |
| 12 | 11 | P47 | I/O | Input/output port | Secondary | RT1 | O | RC type ADC1 measurement resistor sensor connection pin |
| 4 | 3 | P50/EX18 | I/O | Input/output port, External interrupt | Secondary | MD0 | O | Melody 0 output |
| | | | | | Tertiary | SIN1 | I | SSIO1 data input |
| 3 | 2 | P51/EX18 | I/O | Input/output port, External interrupt | Secondary | — | — | — |
| | | | | | Tertiary | SCK1 | I/O | SSIO1 synchronous clock input/output |
| 2 | 1 | P52/EX18 | I/O | Input/output port, External interrupt | Secondary | — | — | — |
| | | | | | Tertiary | SOUT1 | O | SSIO1 data output |
| 97 | 86 | P53/EX18 | I/O | Input/output port, External interrupt | — | — | — | — |
| 96 | 85 | P54/EX18 | I/O | Input/output port, External interrupt | Secondary | — | — | — |
| | | | | | Tertiary | SIN1 | I | SSIO1 data input |
| 95 | 84 | P55/EX18 | I/O | Input/output port, External interrupt | Secondary | — | — | — |
| | | | | | Tertiary | SCK1 | I/O | SSIO1 synchronous clock input/output |
| 94 | 83 | P56/EX18 | I/O | Input/output port, External interrupt | Secondary | — | — | — |
| | | | | | Tertiary | SOUT1 | O | SSIO1 data output |
| 93 | 82 | P57/EX18 | I/O | Input/output port, External interrupt | — | — | — | — |

| PIN No. | PAD No. | Primary function | | | Secondary function or Tertiary function | | | |
|---------|---------|------------------------|-----|------------------------|---|----------|-----|----------|
| | | Pin name | I/O | Function | Secondary/ Tertiary | Pin name | I/O | Function |
| 29 | 24 | COM0 | O | LCD common pin | — | — | — | — |
| 30 | 25 | COM1 | O | LCD common pin | — | — | — | — |
| 31 | 26 | COM2/ SEG0 | O | LCD common/segment pin | — | — | — | — |
| 32 | 27 | COM3/ SEG1 | O | LCD common/segment pin | — | — | — | — |
| 33 | 28 | COM4/ SEG2 | O | LCD common/segment pin | — | — | — | — |
| 34 | 29 | SEG3 | O | LCD segment pin | — | — | — | — |
| 35 | 30 | SEG4 | O | LCD segment pin | — | — | — | — |
| 36 | 31 | SEG5 | O | LCD segment pin | — | — | — | — |
| 37 | 32 | SEG6 | O | LCD segment pin | — | — | — | — |
| 38 | 33 | SEG7 | O | LCD segment pin | — | — | — | — |
| 39 | 34 | SEG8 | O | LCD segment pin | — | — | — | — |
| 40 | 35 | SEG9 | O | LCD segment pin | — | — | — | — |
| 41 | 36 | SEG10 | O | LCD segment pin | — | — | — | — |
| 42 | 37 | SEG11 | O | LCD segment pin | — | — | — | — |
| 43 | 38 | SEG12 | O | LCD segment pin | — | — | — | — |
| 44 | 39 | SEG13 | O | LCD segment pin | — | — | — | — |
| 45 | 40 | SEG14 | O | LCD segment pin | — | — | — | — |
| 46 | 41 | SEG15 | O | LCD segment pin | — | — | — | — |
| 47 | 42 | SEG16 | O | LCD segment pin | — | — | — | — |
| 48 | 43 | SEG17 | O | LCD segment pin | — | — | — | — |
| 52 | 44 | SEG18 | O | LCD segment pin | — | — | — | — |
| 53 | 45 | SEG19 | O | LCD segment pin | — | — | — | — |
| 54 | 46 | SEG20 | O | LCD segment pin | — | — | — | — |
| 55 | 47 | SEG21 | O | LCD segment pin | — | — | — | — |
| 56 | 48 | SEG22 | O | LCD segment pin | — | — | — | — |
| 57 | 49 | SEG23 | O | LCD segment pin | — | — | — | — |
| 58 | 50 | SEG24 | O | LCD segment pin | — | — | — | — |
| 59 | 51 | SEG25 | O | LCD segment pin | — | — | — | — |
| 60 | 52 | SEG26 | O | LCD segment pin | — | — | — | — |
| 61 | 53 | SEG27 | O | LCD segment pin | — | — | — | — |
| 62 | 54 | SEG28 | O | LCD segment pin | — | — | — | — |
| 63 | 55 | SEG29 | O | LCD segment pin | — | — | — | — |
| 64 | 56 | SEG30 | O | LCD segment pin | — | — | — | — |
| 65 | 57 | SEG31 | O | LCD segment pin | — | — | — | — |
| 66 | 58 | P67 ^(*)2) | O | Output port | — | — | — | — |
| | | SEG32 ^(*)3) | O | LCD segment pin | — | — | — | — |
| 67 | 59 | P66 ^(*)2) | O | Output port | — | — | — | — |
| | | SEG33 ^(*)3) | O | LCD segment pin | — | — | — | — |
| 68 | 60 | P65 ^(*)2) | O | Output port | — | — | — | — |
| | | SEG34 ^(*)3) | O | LCD segment pin | — | — | — | — |
| 69 | 61 | P64 ^(*)2) | O | Output port | — | — | — | — |
| | | SEG35 ^(*)3) | O | LCD segment pin | — | — | — | — |
| 70 | 62 | P63 ^(*)4) | O | Output port | — | — | — | — |
| | | SEG36 ^(*)5) | O | LCD segment pin | — | — | — | — |
| 71 | 63 | P62 ^(*)4) | O | Output port | — | — | — | — |
| | | SEG37 ^(*)5) | O | LCD segment pin | — | — | — | — |
| 72 | 64 | P61 ^(*)4) | O | Output port | — | — | — | — |
| | | SEG38 ^(*)5) | O | LCD segment pin | — | — | — | — |
| 73 | 65 | P60 ^(*)4) | O | Output port | — | — | — | — |
| | | SEG39 ^(*)5) | O | LCD segment pin | — | — | — | — |

(*¹) Internally generated, or connect to either positive power supply pin (V_{DD}) or power supply pin for internal logic (V_{DDL}). For details, see "Chapter 22 LCD Drivers."

(*²) Pin for ML610407

(*³) Pin for ML610408/ML610409

(*⁴) Pin for ML610407/ ML610408

(*⁵) Pin for ML610409

1.3.3 Pin Descriptions

| Pin name | I/O | Description | Primary/ Secondary/ Tertiary | Logic |
|-----------------------------------|-----|---|------------------------------------|----------|
| System | | | | |
| RESET_N | I | Reset input pin. When this pin is set to a "L" level, system reset mode is set and the internal section is initialized. When this pin is set to a "H" level subsequently, program execution starts. A pull-up resistor is internally connected. | — | Negative |
| XT0 | I | Crystal connection pin for low-speed clock. A 32.768 kHz crystal resonator is connected to this pin. Capacitors | — | — |
| XT1 | O | C _{DL} and C _{GL} are connected across this pin and V _{SS} . (see appendix C measuring circuit 1) | — | — |
| LSCLK | O | Low-speed clock output. Assigned to the secondary function of the P20 pin. | Secondary | — |
| OUTCLK | O | High-speed clock output pin. This pin is used as the secondary function of the P21 pin. | Secondary | — |
| General-purpose input port | | | | |
| P00 to P04 | I | General-purpose input port. | Primary | Positive |
| General-purpose output port | | | | |
| P20 to P22, P24 | O | General-purpose output port. This cannot be used as the general output port when used as the secondary function. | Primary | Positive |
| General-purpose input/output port | | | | |
| P30 to P35 | I/O | General-purpose input/output port. This cannot be used as the general input/output port when used as the secondary function. | Primary | Positive |
| P40 to P47 | I/O | General-purpose input/output port. This cannot be used as the general input/output port when used as the secondary or tertiary function. | Primary | Positive |
| P50 to P57 | I/O | General-purpose input/output port. This cannot be used as the general input/output port when used as the secondary function. | Primary | Positive |
| P60 to P63 | O | General-purpose output port. Incorporated only into ML610407/8, and not into ML610409. | Primary | Positive |
| P64 to P67 | O | General-purpose output port. Incorporated only into ML610407, and not into ML610408/ ML610409. | Primary | Positive |

| Pin name | I/O | Description | Primary/ Secondary/ Tertiary | Logic |
|----------------------------------|-----|---|------------------------------------|-----------------------|
| UART | | | | |
| TXD0 | O | UART data output pin. This pin is used as the secondary function of the P43 pin. | Secondary | Positive |
| RXD0 | I | UART data input pin. This pin is used as the secondary function of the P42 or the primary function of the P02 pin. | Primary/ Secondary | Positive |
| Synchronous serial (SSIO) | | | | |
| SCK0 | I/O | Synchronous serial clock input/output pin. This pin is used as the tertiary function of the P41 or P45 pin. | Tertiary | — |
| SIN0 | I | Synchronous serial data input pin. This pin is used as the tertiary function of the P40 or P44 pin. | Tertiary | Positive |
| SOUT0 | O | Synchronous serial data output pin. This pin is used as the tertiary function of the P42 or P46 pin. | Tertiary | Positive |
| SCK1 | I/O | Synchronous serial clock input/output pin. Assigned to the tertiary function of the P51 pin and P55 pin. | Tertiary | — |
| SIN1 | I | Synchronous serial data input pin. Assigned to the tertiary function of the P50 pin and P54 pin. | Tertiary | Positive |
| SOUT1 | O | Synchronous serial data output pin. Assigned to the tertiary function of the P52 pin and P56 pin. | Tertiary | Positive |
| PWM | | | | |
| PWM0 | O | PWM0 output pin. This pin is used as the secondary function of the P24 and tertiary function of the P43 pin. | Secondary Tertiary | Positive |
| TOP02CK | O | PWM0 external clock input pin. This pin is used as the primary function of the P04 pin and P44 pin. | Primary | — |
| External interrupt | | | | |
| EXI0-4 | I | External maskable interrupt input pins. Interrupt enable and edge selection can be performed for each bit by software. These pins are used as the primary functions of the P00 to P04 pins. | Primary | Positive/ negative |
| EXI8 | I | External maskable interrupt input pins. Interrupt enable and edge selection can be performed for each bit by software. Assigned to the primary function of the P50 to P57 pins. | Primary | Positive/ negative |
| Capture | | | | |
| CAP0 | I | Capture trigger input pins. The value of the time base counter is captured in the register synchronously with the interrupt edge selected by software. These pins are used as the primary functions of the P00 pin(CAP0) and P01 pin(CAP1). | Primary | Positive/ negative |
| CAP1 | I | | Primary | Positive/ negative |
| Timer | | | | |
| TOP02CK | I | External clock input pin used for both Timer 0 and Timer 2. This pin is used as the primary function of the P04 pin and P44 pin. | Primary | — |
| T13CK | I | External clock input pin used for both Timer 1 and Timer 3. This pin is used as the primary function of the P45 pin. | Primary | — |
| Melody | | | | |
| MD0 | O | Melody/buzzer signal output pin. This pin is used as the secondary function of the P22 and P50 pins. | Secondary | Positive/ negative |
| LED drive | | | | |
| LED0 to LED2, LED4 | O | N-channel open drain output pins to drive LED. This pin is used as the primary function of the P20 to P22 and P24 pins. | Primary | Positive /negative |

| Pin name | I/O | Description | Primary/ Secondary/ Tertiary | Logic |
|-----------------------------------|-----|---|------------------------------------|-------|
| RC oscillation type A/D converter | | | | |
| IN0 | I | Channel 0 oscillation input pin. This pin is used as the secondary function of the P30 pin. | Secondary | — |
| CS0 | O | Channel 0 reference capacitor connection pin. This pin is used as the secondary function of the P31 pin. | Secondary | — |
| RS0 | O | This pin is used as the secondary function of the P32 pin which is the reference resistor connection pin of Channel 0. | Secondary | — |
| RCT0 | O | Resistor/capacitor sensor connection pin of Channel 0 for measurement. This pin is used as the secondary function of the P34 pin. | Secondary | — |
| RT0 | O | Resistor sensor connection pin of Channel 0 for measurement. This pin is used as the secondary function of the P33 pin. | Secondary | — |
| RCM | O | RC oscillation monitor pin. This pin is used as the secondary function of the P35 pin. | Secondary | — |
| IN1 | I | Oscillation input pin of Channel 1. This pin is used as the secondary function of the P44 pin. | Secondary | — |
| CS1 | O | Reference capacitor connection pin of Channel 1. This pin is used as the secondary function of the P45 pin. | Secondary | — |
| RS1 | O | Reference resistor connection pin of Channel 1. This pin is used as the secondary function of the P46 pin. | Secondary | — |
| RT1 | O | Resistor sensor connection pin for measurement of Channel 1. This pin is used as the secondary function of the P47 pin. | Secondary | — |
| LCD drive signal | | | | |
| COM0 to COM4 | O | Common output pins. COM2, COM3, and COM4 can be switched to SEG0, SEG1, and SEG2, respectively, through the register setting. To change the setting, switch between COM4 and SEG2 for one pin and switch between COM3, COM4 and SEG1, SEG2 for two pins. | — | — |
| SEG0 to SEG31 | O | Segment output pin. The SEG0, SEG1, and SEG2 pins are for switching the register setting with the COM2, COM3, and COM4. | — | — |
| SEG32 to SEG35 | O | Segment output pin. Incorporated into ML610408/ML610409, not into ML610407. | — | — |
| SEG36 to SEG39 | O | Segment output pin. Incorporated into ML610409, not into ML610407/ML610408. | — | — |
| LCD driver power supply | | | | |
| V _{L1} | — | Power supply pin for LCD bias (internally generated) or power supply connection pin. Depending on LCD Bias setting and V _{DD} voltage level, V _{DD} or V _{DDL} or capacitor is connected. For details of the connection method, see Chapter 22, "LCD Drivers". | — | — |
| V _{L2} | — | | — | — |
| V _{L3} | — | | — | — |
| C1 | — | Power supply pins for LCD bias (internally generated). Capacitor C ₁₂ (see Appendix C measuring circuit 1) is connected between C1 and C2. | — | — |
| C2 | — | | — | — |

| Pin name | I/O | Description | Primary/ Secondary/ Tertiary | Logic |
|------------------|-----|---|------------------------------------|----------|
| Test | | | | |
| TEST0 | I/O | Pin for testing. A pull-down resistor is internally connected. | — | Positive |
| Power supply | | | | |
| V _{SS} | — | Negative power supply pin. | — | — |
| V _{DD} | — | Positive power supply pin. | — | — |
| V _{DDL} | — | Positive power supply pin (internally generated) for internal logic. Capacitors C _{L0} and C _{L1} (see Appendix C measuring circuit 1) are connected between this pin and V _{SS} . | — | — |

1.3.4 Handling of Unused Pins

Table 1-2 shows methods of terminating the unused pins.

Table 1-2 Termination of Unused Pins

| Pin | Recommended pin handling |
|-----------------|------------------------------------|
| V _{L1} | Open |
| V _{L2} | Open |
| V _{L3} | Open |
| C1, C2 | Open |
| RESET_N | Open |
| TEST0 | V _{SS} |
| P00 to P04 | V _{DD} or V _{SS} |
| P20 to P22, P24 | Open |
| P30 to P35 | Open |
| P40 to P47 | Open |
| P50 to P57 | Open |
| P60 to P67 | Open |
| COM0 to COM4 | Open |
| SEG0 to SEG39 | Open |

Note:

It is recommended to set the unused input ports and input/output ports to the inputs with pull-down resistors/pull-up resistors or the output mode since the supply current may become excessively large if the pins are left open in the high impedance input setting.

CPU and Memory Space

2. CPU and Memory Space

2.1 Overview

This LSI includes 8-bit CPU nX-U8/100 and the memory model is SMALL model.
 For details of the CPU nX-U8/100, see “nX-U8/100 Core Instruction Manual”.

2.2 Program Memory Space

The program memory space is used to store program codes, table data (ROM window), or vector tables.
 The program codes have a length of 16 bits and are specified by a 16-bit program counter (PC).
 The ROM window area data has a length of 8 bits and can be used as table data.
 The vector table, which has 16-bit long data, can be used as reset vectors, hardware interrupt vectors, and software interrupt vectors.
 The program memory space consists of one segment and has 16-Kbyte (8-Kword) capacity.
 Figure 2-1 shows the configuration of the program memory space.

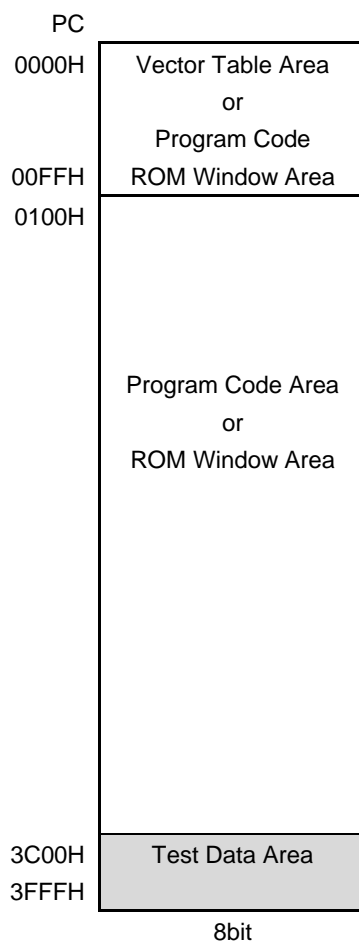

Figure 2-1 Configuration of Program Memory Space

Note:

- The 1024 bytes (512 words) from 3C00H to 3FFFH are the test data area. From 3DE8H to 3DFFH, set the Mask ROM version mode data programmed by using the Mask ROM version emulation function of ML610Q407. For the Mask ROM version emulation function, see “ML610Q407 user’s manual : Chapter 25 Mask ROM Version Emulation Function”.
- Set “0FFH” data (BRK instruction) in the unused area of the program memory space.

2.3 Data Memory Space

The data memory space of this LSI consists of the ROM window area, 1KByte RAM area, and SFR area of Segment 0. The data memory has the 8-bit length and is specified by the addressing specified by each instruction.

Figure 2-2 shows the configuration of the data memory space.

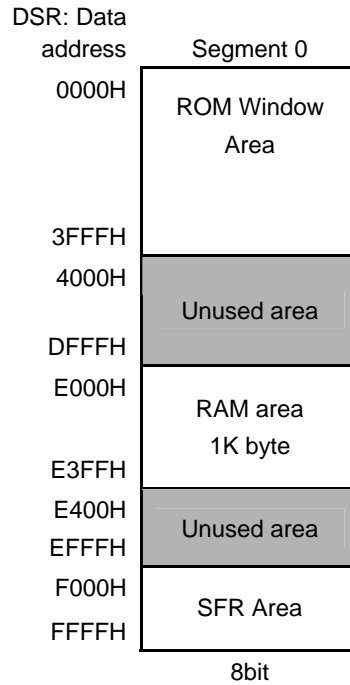

Figure 2-2 Configuration of Data Memory Space

Note:

- The contents of the RAM area are undefined at system reset. Initialize this area by software.

2.4 Instruction Length

The length of an instruction is 16 bits.

2.5 Data Type

The data types supported include byte (8 bits) and word (16 bits).

2.6 Description of Registers

2.6.1 List of Registers

| Address | Name | Symbol (Byte) | Symbol (Word) | R/W | Size | Initial value |
|---------|-----------------------|---------------|---------------|-----|------|---------------|
| 0F000H | Data segment register | DSR | — | R/W | 8 | 00H |

2.6.2 Data Segment Register (DSR)

Address: 0F000H

Access: R/W

Access size: 8-bit

Initial value: 00H

| | | | | | | | | |
|---------------|-----|-----|-----|-----|------|------|------|------|
| | 7 | 6 | 5 | 4 | 3 | 2 | 1 | 0 |
| DSR | — | — | — | — | DSR3 | DSR2 | DSR1 | DSR0 |
| R/W | R/W | R/W | R/W | R/W | R/W | R/W | R/W | R/W |
| Initial value | 0 | 0 | 0 | 0 | 0 | 0 | 0 | 0 |

DSR is a special function register (SFR) to retain a data segment.

Always use this register with the initial state (0). For details of DSR, see “nX-U8/100 Core Instruction Manual”.

[Description of Bits]

- **DSR3-DSR0** (bits 3 to 0)

| DSR3 | DSR2 | DSR1 | DSR0 | Description |
|---------------------|------|------|------|---------------|
| 0 | 0 | 0 | 0 | Initial value |
| In other than above | | | | Prohibited |

Reset Function

3. Reset Function

3.1 Overview

This LSI has the five reset functions shown below. If any of the five reset conditions is satisfied, this LSI enters system reset mode.

- Reset by the RESET_N pin
- Reset by power-on detection
- Reset by the low-speed oscillation stop detection (Cancellation by a mask option is possible)
- Reset by the 2nd watchdog timer (WDT) overflow
- Software reset by execution of the BRK instruction

3.1.1 Features

- The RESET_N pin has an internal pull-up resistor
- The low-speed oscillation stop detection time is 19 ms (typ.)
- 250 ms, 1 sec, 4 sec, or 16 sec can be selected as the watchdog timer (WDT) overflow period
- Built-in reset status register (RSTAT) indicating the reset generation causes
- Only the CPU is reset by the BRK instruction (neither the RAM area nor the SFR area are reset).

3.1.2 Configuration

Figure 3-1 shows the configuration of the reset generation circuit.

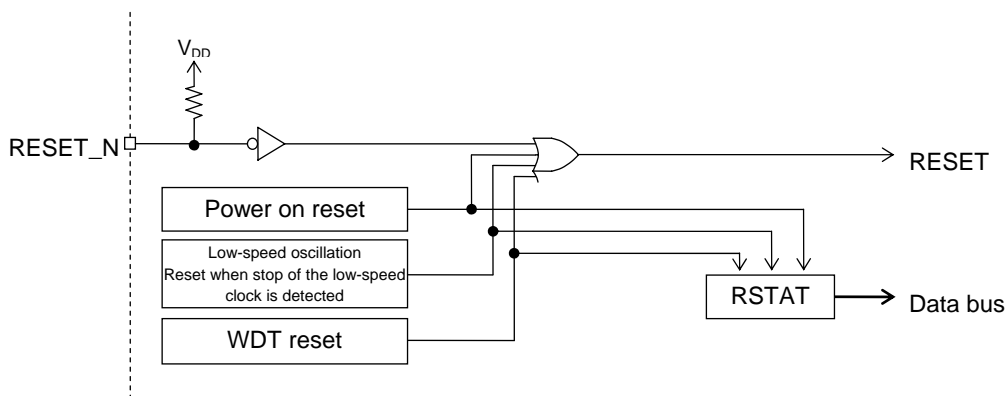

RSTAT : Reset status register

Figure 3-1 Configuration of Reset Generation Circuit

3.1.3 List of Pins

| Pin name | Input/output | Function |
|----------|--------------|-----------------|
| RESET_N | I | Reset input pin |

3.2 Description of Registers

3.2.1 List of Registers

| Address | Name | Symbol (Byte) | Symbol (Word) | R/W | Size | Initial value |
|---------|-----------------------|---------------|---------------|-----|------|---------------|
| 0F001H | Reset status register | RSTAT | — | R/W | 8 | — |

3.2.2 Reset Status Register (RSTAT)

Address: 0F001H

Access: R/W

Access size: 8-bit

Initial value: Undefined

| | 7 | 6 | 5 | 4 | 3 | 2 | 1 | 0 |
|---------------|-----|-----|-----|-----|-----|------|------|-----|
| RSTAT | — | — | — | — | — | WDTR | XSTR | POR |
| R/W | R/W | R/W | R/W | R/W | R/W | R/W | R/W | R/W |
| Initial value | 0 | 0 | 0 | 0 | 0 | 0 | X | 1 |

RSTAT is a special function register (SFR) that indicates the causes by which the reset is generated.

At the occurrence of reset, the contents of RSTAT are not initialized, while the bit indicating the cause of the reset is set to "1". When checking the reset cause using this function, perform write operation to RSTAT in advance and initialize the contents of RSTAT to "00H".

[Description of Bits]

- **POR** (bit 0)

The POR bit is a flag that indicates that the power-on reset is generated. This bit is set to "1" when powered on.

| POR | Description |
|-----|------------------------------|
| 0 | Power-on reset not generated |
| 1 | Power-on reset generated |

- **XSTR** (bit 1)

The XSTR bit is a flag that indicates the generation of low-speed oscillation stop detect reset. When low-speed oscillation stops for the period specified by the low-speed oscillation stop detection time (T_{STOP}) or more, this bit is set to "1". When the low-speed oscillation stop detection reset is disabled by a mask option, it always returns the value "0". For the Mask-Option, see Chapter 24, "Mask Option".

| XSTR | Description |
|------|--|
| 0 | Low-speed oscillation stop detect reset not occurred |
| 1 | Low-speed oscillation stop detect reset occurred |

- **WDTR** (bit 2)

The WSDTR is a flag that indicates that the watchdog timer reset is generated. This bit is set to "1" when the reset by overflow of the watchdog timer is generated.

| WDTR | Description |
|------|-----------------------------------|
| 0 | Watchdog timer reset not occurred |
| 1 | Watchdog timer reset occurred |

Note:

No flag is provided that indicates the occurrence of reset by the RESET_N pin.

3.3 Description of Operation

3.3.1 Operation of System Reset Mode

System reset has the highest priority among all the processings and any other processing being executed up to then is cancelled.

The system reset mode is set by any of the following causes.

- Reset by the RESET_N pin
- Reset by power-on detection
- Reset by the low-speed oscillation stop detection (Cancellation by a mask option is possible)
- Reset by watchdog timer (WDT) overflow
- Software reset by the BRK instruction (only the CPU is reset)

In system reset mode, the following processing is performed.

- (1) The power circuit is initialized. However, it is not initialized by the reset by the BRK instruction execution. For the details of the power circuit, refer to Chapter 23, "Power Circuit".
- (2) All the special function registers (SFRs) whose initial value is not undefined are initialized. However, the initialization is not performed by software reset due to execution of the BRK instruction. See Appendix A "Registers" for the initial values of the SFRs.
- (3) CPU is initialized.
 - All the registers in CPU are initialized.
 - The contents of addresses 0000H and 0001H in the program memory are set to the stack pointer (SP).
 - The contents of addresses 0002H and 0003H in the program memory are set to the program counter (PC). However, when the interrupt level (ELEEVL) of the program status word (PSW) at reset by the BRK instruction is 1 or lower, the contents of addresses 0004H and 0005H of the program memory are set in the program counter (PC). For the BRK instruction, see "nX-U8/100 Core Instruction Manual".

Note:

In system reset mode, the contents of data memory and those of any SFR whose initial value is undefined are not initialized and are undefined. Initialize them by software.

In system reset mode by the BRK instruction, no special function register (SFR) that has a fixed initial value is initialized either. Therefore initialize such an SFR by software.

MCU Control Function

4. MCU Control Function

4.1 Overview

The operating states of this LSI are classified into the following 4 modes including system reset mode:

- (1) System reset mode
- (2) Program run mode
- (3) HALT Mode
- (4) STOP mode

For system reset mode, see Chapter 3, "Reset Function".

4.1.1 Features

- HALT mode, where the CPU stops operating and only the peripheral circuit is operating
- STOP mode, where both low-speed oscillation and high-speed oscillation stop
- Stop code acceptor function, which controls transition to STOP mode
- Block control function, which power downs the circuits of unused peripherals (reset registers and stop clock supplies)

4.1.2 Configuration

Figure 4-1 shows an operating state transition diagram.

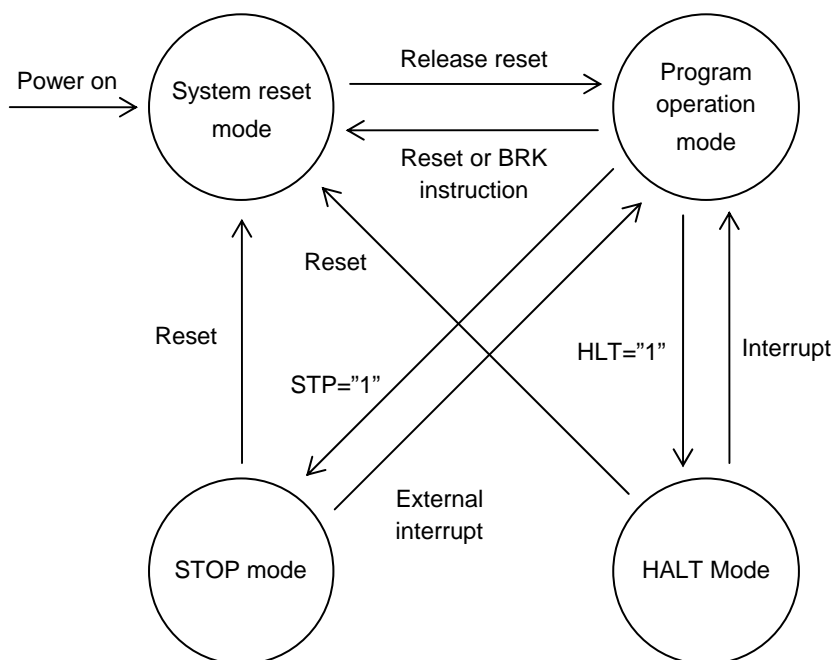

Figure 4-1 Operating State Transition Diagram

4.2 Description of Registers

4.2.1 List of Registers

| Address | Name | Symbol (Byte) | Symbol (Word) | R/W | Size | Initial value |
|---------|--------------------------|---------------|---------------|-----|------|---------------|
| 0F008H | Stop code acceptor | STPACP | — | W | 8 | — |
| 0F009H | Standby control register | SBYCON | — | W | 8 | 00H |
| 0F028H | Block control register 0 | BLKCON0 | — | R/W | 8 | 00H |
| 0F029H | Block control register 1 | BLKCON1 | — | R/W | 8 | 00H |
| 0F02AH | Block control register 2 | BLKCON2 | — | R/W | 8 | 00H |
| 0F02BH | Block control register 3 | BLKCON3 | — | R/W | 8 | 00H |
| 0F02CH | Block control register 4 | BLKCON4 | — | R/W | 8 | 00H |

4.2.2 Stop Code Acceptor (STPACP)

Address: 0F008H

Access: W

Access size: 8-bit

Initial value:—(Undefined)

| | | | | | | | | |
|---------------|---|---|---|---|---|---|---|---|
| | 7 | 6 | 5 | 4 | 3 | 2 | 1 | 0 |
| STPACP | — | — | — | — | — | — | — | — |
| W | W | W | W | W | W | W | W | W |
| Initial value | - | - | - | - | - | - | - | - |

STPACP is a write-only special function register (SFR) that is used for setting a STOP mode.

When STPACP is read, “00H” is read.

When data is written to STPACP in the order of “5nH”(n: an arbitrary value) and “0AnH”(n: an arbitrary value), the stop code acceptor is enabled. When the STP bit of the standby control register (SBYCON) is set to “1” in this state, the mode is changed to the STOP mode. When the STOP mode is set, the STOP code acceptor is disabled.

When another instruction is executed between the instruction that writes “5nH” to STPACP and the instruction that writes “0AnH”, the stop code acceptor is enabled after “0AnH” is written. However, if data other than “0AnH” is written to STPACP after “5nH” is written, the “5nH” write processing becomes invalid so that data must be written again starting from “5nH”.

During a system reset, the stop code acceptor is disabled.

Note:

The STOP code acceptor cannot be enabled on the condition of that both any interrupt enable flag and the corresponding interrupt request flag are “1”(An interrupt request occurrence with resetting MIE flag will have the condition).

4.2.3 Standby Control Register (SBYCON)

Address: 0F009H
 Access: W
 Access size: 8-bit
 Initial value: 00H

| | | | | | | | | |
|---------------|---|---|---|---|---|---|-----|-----|
| | 7 | 6 | 5 | 4 | 3 | 2 | 1 | 0 |
| SBYCON | — | — | — | — | — | — | STP | HLT |
| W | W | W | W | W | W | W | W | W |
| Initial value | 0 | 0 | 0 | 0 | 0 | 0 | 0 | 0 |

SBYCON is a special function register (SFR) to control operating mode of MCU.

[Description of Bits]

- STP** (bit 1)
 The STP bit is used for setting the STOP mode. When the STP bit is set to “1” with the stop code adapter enabled by using STPACP, the mode is changed to the STOP mode. When any of the P00 to P04 interrupt requests enabled by the Interrupt Enable Register 1 (IE1) occurs or an external 8 interrupt request enabled by the Interrupt Enable Register 2 (IE2) occurs, the STP becomes "0" and the operation returns to the program run mode.
- HLT** (bit 0)
 The HALT bit is used for setting a HALT mode. When the HALT bit is set to “1”, the mode is changed to the HALT mode. When the WDT interrupt request or enabled (the interrupt enable flag is “1”) interrupt request is issued, the HALT bit is set to “1” and the mode is returned to program run mode.

| STP | HLT | Description |
|-----|-----|----------------------------------|
| 0 | 0 | Program run mode (initial value) |
| 0 | 1 | HALT Mode |
| 1 | 0 | STOP mode |
| 1 | 1 | Prohibited |

Note:

The mode cannot be changed to HALT mode or STOP mode on the condition of that both any interrupt enable flag and the corresponding interrupt request flag are “1”(An interrupt request occurrence with resetting MIE flag will have the condition).

When a maskable interrupt source (interrupt with enable bit) occurs while the MIE flag of the program status word (PSW) in the nX-U8/100 core is “0”, the STOP mode and the HALT mode are simply released and interrupt processing is not performed. For details of PSW, see “nX-U8/100 Core Instruction Manual”.

4.2.4 Block Control Register 0 (BLKCON0)

Address: 0F028H
Access: R/W
Access size: 8-bit
Initial value: 00H

| | | | | | | | | |
|---------------|-----|-----|-----|-----|------|------|------|------|
| | 7 | 6 | 5 | 4 | 3 | 2 | 1 | 0 |
| BLKCON0 | — | — | — | — | DTM3 | DTM2 | DTM1 | DTM0 |
| R/W | R/W | R/W | R/W | R/W | R/W | R/W | R/W | R/W |
| Initial value | 0 | 0 | 0 | 0 | 0 | 0 | 0 | 0 |

BLKCON0 is a special function register (SFR) to control each block operation.

[Description of Bits]

- **DTM0** (bit 0)
The DTM0 bit is used to control Timer 0 operation.

| DTM0 | Description |
|------|--|
| 0 | Enable operating Timer 0 (initial value) |
| 1 | Disable operating Timer 0 |

- **DTM1** (bit 1)
The DTM1 bit is used to control Timer 1 operation.

| DTM1 | Description |
|------|--|
| 0 | Enable operating Timer 1 (initial value) |
| 1 | Disable operating Timer 1 |

- **DTM2** (bit 2)
The DTM2 bit is used to control Timer 2 operation.

| DTM2 | Description |
|------|--|
| 0 | Enable operating Timer 2 (initial value) |
| 1 | Disable operating Timer 2 |

- **DTM3** (bit 3)
The DTM3 bit is used to control Timer 3 operation.

| DTM3 | Description |
|------|--|
| 0 | Enable operating Timer 3 (initial value) |
| 1 | Disable operating Timer 3 |

Note:

- When any flag is set to "1" (disable operation), the function of the applicable block is reset (all registers are initialized) and the clock supply to such block stops. When this flag is set to "1", the writing to all registers in the applicable block becomes invalid, and thus the reading from such register becomes the initial value. When using the function of the applicable block, ensure to reset the applicable flag of this block control register to "0" (enable operation).
- See Chapter 9, "Timers" for detail about operation of Timer 0, Timer 1, Timer 2 and Timer 3.

4.2.5 Block Control Register 1 (BLKCON1)

Address: 0F029H
 Access: R/W
 Access size: 8-bit
 Initial value: 00H

| | | | | | | | | |
|---------------|-----|-------|-----|-----|-----|-----|-----|------|
| | 7 | 6 | 5 | 4 | 3 | 2 | 1 | 0 |
| BLKCON1 | — | DCAPR | — | — | — | — | — | DPW0 |
| R/W | R/W | R/W | R/W | R/W | R/W | R/W | R/W | R/W |
| Initial value | 0 | 0 | 0 | 0 | 0 | 0 | 0 | 0 |

BLKCON1 is a special function register (SFR) to control each block operation.

[Description of Bits]

- **DPW0** (bit 0)
 The DPW0 bit is used to control PWM0 operation.

| DPW0 | Description |
|------|---------------------------------------|
| 0 | Enable operating PWM0 (initial value) |
| 1 | Disable operating PWM0 |

- **DCAPR** (bit 6)
 The DCAPR bit is used to control Capture operation.

| DCAPR | Description |
|-------|--|
| 0 | Enable operating Capture (initial value) |
| 1 | Disable operating Capture |

Note:

- When any flag is set to "1" (disable operation), the function of the applicable block is reset (all registers are initialized) and the clock supply to such block stops. When this flag is set to "1", the writing to all registers in the applicable block becomes invalid, and thus the reading from such register becomes the initial value. When using the function of the applicable block, ensure to reset the applicable flag of this block control register to "0" (enable operation).
- See Chapter 8, "Capture" for detail about operation of Capture.
- See Chapter 10, "PWM" for detail about operation of PWM.

4.2.6 Block Control Register 2 (BLKCON2)

Address: 0F02AH
Access: R/W
Access size: 8-bit
Initial value: 00H

| | | | | | | | | |
|---------------|-----|-----|-----|-----|-----|------|-------|-------|
| | 7 | 6 | 5 | 4 | 3 | 2 | 1 | 0 |
| BLKCON2 | — | — | — | — | — | DUA0 | DSIO1 | DSIO0 |
| R/W | R/W | R/W | R/W | R/W | R/W | R/W | R/W | R/W |
| Initial value | 0 | 0 | 0 | 0 | 0 | 0 | 0 | 0 |

BLKCON2 is a special function register (SFR) to control each block operation.

[Description of Bits]

- **DSIO0** (bit 0)
The DSIO0 bit is used to control the synchronous serial port 0 operation.

| DSIO0 | Description |
|-------|--|
| 0 | Enable operating synchronous serial port 0 (initial value) |
| 1 | Disable operating synchronous serial port 0 |

- **DSIO1** (bit 1)
The DSIO1 bit is used to control the synchronous serial port 1 operation.

| DSIO1 | Description |
|-------|--|
| 0 | Enable operating synchronous serial port 1 (initial value) |
| 1 | Disable operating synchronous serial port 1 |

- **DUA0** (bit 2)
The DUA0 bit is used to control UART operation.

| DUA0 | Description |
|------|---------------------------------------|
| 0 | Enable operating UART (initial value) |
| 1 | Disable operating UART |

Note:

- When any flag is set to "1" (disable operation), the function of the applicable block is reset (all registers are initialized) and the clock supply to such block stops. When this flag is set to "1", the writing to all registers in the applicable block becomes invalid, and thus the reading from such register becomes the initial value. When using the function of the applicable block, ensure to reset the applicable flag of this block control register to "0" (enable operation).
- See Chapter 13, "UART" for detail about operation of UART.
- See Chapter 12, "Synchronous Serial Port" for detail about operation of SSIO.

4.2.7 Block Control Register 3 (BLKCON3)

Address: 0F02BH
 Access: R/W
 Access size: 8-bit
 Initial value: 00H

| | | | | | | | | |
|---------------|-----|-----|-----|-----|-----|-----|-----|------|
| | 7 | 6 | 5 | 4 | 3 | 2 | 1 | 0 |
| BLKCON3 | — | — | — | — | — | — | — | DMD0 |
| R/W | R/W | R/W | R/W | R/W | R/W | R/W | R/W | R/W |
| Initial value | 0 | 0 | 0 | 0 | 0 | 0 | 0 | 0 |

BLKCON3 is a special function register (SFR) to control each block operation.

[Description of Bits]

- **DMD0** (bit 0)

The DMD0 bit is used to control the Melody Driver 0 operation.

| DMD0 | Description |
|------|--|
| 0 | Enable operating Melody/Buzzer (initial value) |
| 1 | Disable operating Melody/Buzzer |

Note:

- When any flag is set to "1" (disable operation), the function of the applicable block is reset (all registers are initialized) and the clock supply to such block stops. When this flag is set to "1", the writing to all registers in the applicable block becomes invalid, and thus the reading from such register becomes the initial value. When using the function of the applicable block, ensure to reset the applicable flag of this block control register to "0" (enable operation).
- See Chapter 20, "Melody Driver" for detail about operation of Melody/Buzzer.

4.2.8 Block Control Register 4 (BLKCON4)

Address: 0F02CH
Access: R/W
Access size: 8-bit
Initial value: 00H

| | | | | | | | | |
|---------------|-----|------|-----|-----|-----|-----|------|-----|
| | 7 | 6 | 5 | 4 | 3 | 2 | 1 | 0 |
| BLKCON4 | — | DLCD | — | — | — | — | DRAD | — |
| R/W | R/W | R/W | R/W | R/W | R/W | R/W | R/W | R/W |
| Initial value | 0 | 0 | 0 | 0 | 0 | 0 | 0 | 0 |

BLKCON4 is a special function register (SFR) to control each block operation.

[Description of Bits]

- **DRAD** (bit 1)
The DRAD bit is used to control the RC oscillation type A/D converter operation.

| DRAD | Description |
|------|--|
| 0 | Enable operating RC oscillation type A/D converter (initial value) |
| 1 | Disable operating RC oscillation type A/D converter |

- **DLCD** (bit 6)
The DLCD bit is used to control LCD driver operation.

| DLCD | Description |
|------|---|
| 0 | Enable operating LCD driver (initial value) |
| 1 | Disable operating LCD driver |

Note:

- When any flag is set to "1" (disable operation), the function of the applicable block is reset (all registers are initialized) and the clock supply to such block stops. When this flag is set to "1", the writing to all registers in the applicable block becomes invalid, and thus the reading from such register becomes the initial value. When using the function of the applicable block, ensure to reset the applicable flag of this block control register to "0" (enable operation).
- See Chapter 22, "LCD Driver" for detail about operation of LCD driver.
- See Chapter 21, "RC Oscillation Type A/D Converter" for detail about operation of RC oscillation type A/D converter.

4.3 Description of Operation

4.3.1 Program Run Mode

The program run mode is the state where the CPU executes instructions sequentially.

At power-on reset, low-speed oscillation stop detect reset, WDT overflow reset, or RESET_N pin reset, the CPU executes instructions from the addresses that are set in addresses 0002H and 0003H of program memory (ROM) after the system reset mode is released.

At reset by the BRK instruction, the CPU executes instructions from the addresses that are set in the addresses 0004H and 0005H of the program memory after the system reset mode is released. However, when the value of the interrupt level bit (ELEVEL) of the program status word (PSW) is 02H or higher at execution of the BRK instruction (after the occurrence of the WDT interrupt), the CPU executes instructions from the addresses that are set in the addresses 0002H and 0003H.

For details of the BRK instruction and PSW, see the “nX-U8/100 Core Instruction Manual” and for the reset function, see Chapter 3, “Reset Function”.

4.3.2 HALT Mode

The HALT mode is the state where the CPU interrupts execution of instructions and only the peripheral circuits are running.

When the HLT bit of the standby control register (SBYCON) is set to “1”, the HALT mode is set.

When a WDT interrupt request, or an interrupt request enabled by an interrupt enable register (IE1–IE7) is issued, the HLT bit is set to “0” on the falling edge of the next system clock (SYSCLK) and the HALT mode is returned to the program run mode released.

Figure 4-2 shows the operation waveforms in HALT mode.

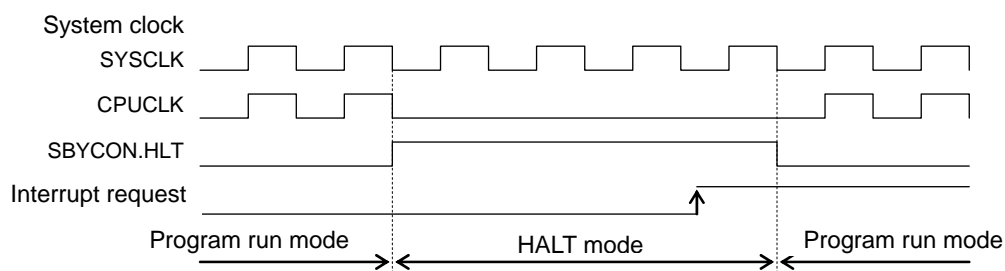

Figure 4-2 Operation Waveforms in HALT Mode

Note:

Since up to two instructions are executed during the period between HALT mode release and a transition to interrupt processing, place two NOP instructions next to the instruction that sets the HLT bit to “1”.

4.3.3 STOP mode

The STOP mode is the state where low-speed oscillation and high-speed oscillation stop and the CPU and peripheral circuits stop the operation.

When the stop code acceptor is enabled by writing “5nH”(n: an arbitrary value) and “0AnH”(n: an arbitrary value) to the stop code acceptor (STPACP) sequentially and the STP bit of the standby control register (SBYCON) is set to “1”, the STOP mode is entered. When the STOP mode is set, the STOP code acceptor is disabled.

When any of the P00 to P04 interrupt requests or an external 8 interrupt request occurs with the interrupt enabled (the interrupt enable flag is "1"), the STP bit is set to "0", the STOP mode is released, and the mode is returned to the program run mode.

4.3.3.1 STOP Mode When CPU Operates with Low-Speed Clock

When the stop code acceptor is in the enabled state and the STP bit of SBYCON is set to “1”, the STOP mode is entered, stopping low-speed oscillation and high-speed oscillation.

When any of the P00 to P04 interrupt request or an external 8 interrupt request occurs with the interrupt enabled (interrupt enabled flag is "1") state, the STP bit becomes "0" and the low-speed oscillation resumes. If the high-speed clock was oscillating before the STOP mode is entered, the high-speed oscillation restarts. When the high-speed clock was not oscillating before the STOP mode is entered, high-speed oscillation does not start.

When an interrupt request occurs, the STOP mode is released after the elapse of the low-speed oscillation start time (T_{XTL}) and the low-speed clock (LSCLK) oscillation stabilization time (8192-pulse count), the mode is returned to the program run mode, and the low-speed clock (LSCLK) restarts supply to the peripheral circuits. If the high-speed clock already started oscillation at this time, the high-speed clocks (OSCLK and HSCLK) also restart supply to the peripheral circuits.

For the low-speed oscillation start time (T_{XTL}), see Appendix C, “Electrical Characteristics”.

Figure 4-3 shows the operation waveforms in STOP mode when CPU operates with the low-speed clock.

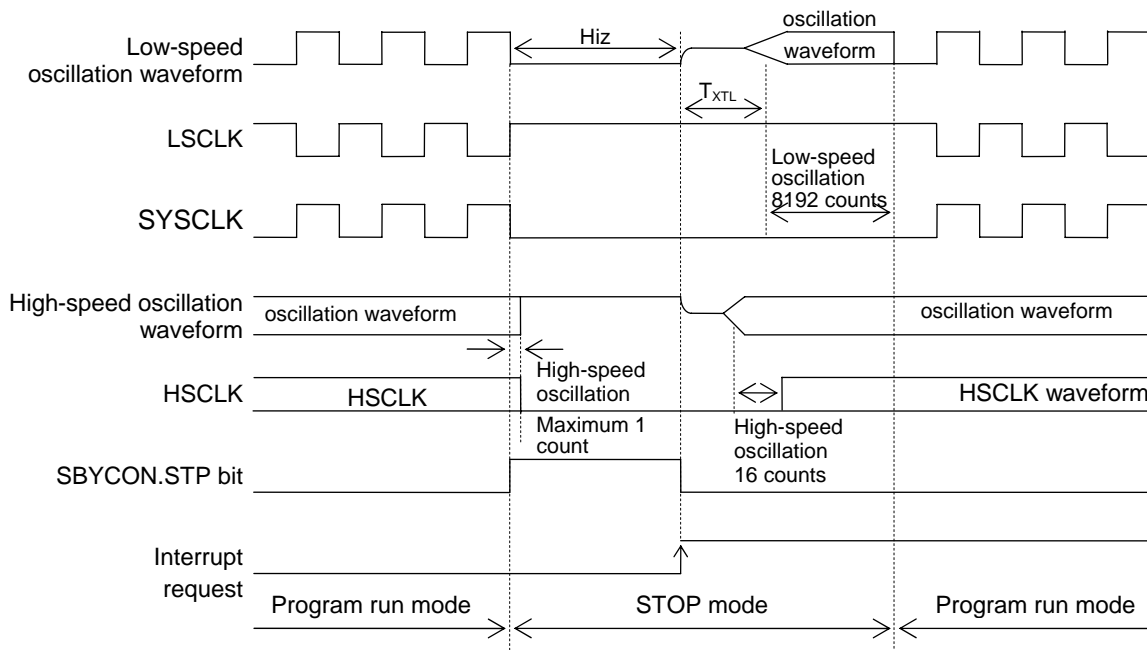

Figure 4-3 Operation Waveforms in STOP Mode When CPU Operates with Low-Speed Clock

4.3.3.2 STOP Mode When CPU Operates with High-Speed Clock

When the CPU is operating with the high-speed clock and the STP bit of SBYCON is set to “1” with the stop code acceptor enabled, the STOP mode is entered and high-speed oscillation and low-speed oscillation stop.

When any of the P00 to P04 interrupt request or an external 8 interrupt request occurs with the interrupt enabled (interrupt enabled flag is "1") state, the STP bit becomes "0" and the high-speed and low-speed oscillation resumes.

When an interrupt request is issued, the STOP mode is released after the elapse of the high-speed oscillation start time (T_{RC}) and the high-speed clock (OSCLK) oscillation stabilization time (16-pulse count), the mode is returned to the program run mode, and the high-speed clocks (OSCLK and HSCLK) restart supply to the peripheral circuits.

The low-speed clock (LSCLK) restarts supply to the peripheral circuits after the elapse of the low-speed oscillation start time (T_{XTL}) and low-speed clock (LSCLK) oscillation stabilization time (8192 count).

For the high-speed oscillation start time (T_{XTH}) and low-speed oscillation start time (T_{XTL}), see the “Electrical Characteristics” Section in Appendix C.

Figure 4-4 shows the operation waveforms in STOP mode when CPU operates with the high-speed clock.

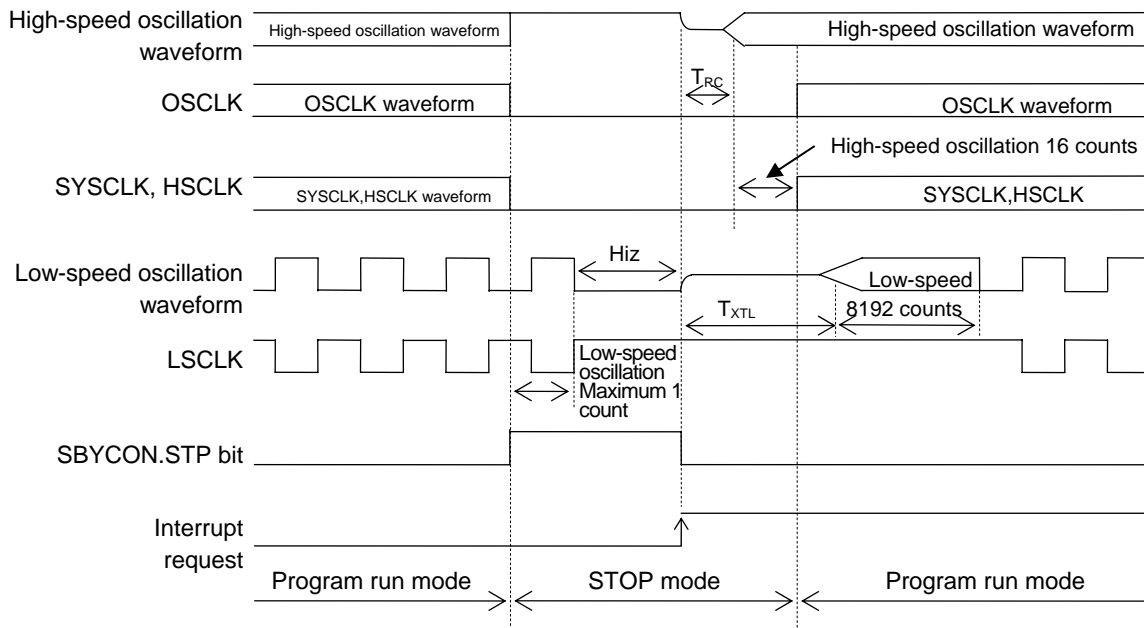

Figure 4-4 Operation Waveforms in STOP Mode When CPU Operates with High-Speed Clock

Note:

Since up to two instructions are executed during the period between STOP mode release and a transition to interrupt processing, place two NOP instructions next to the instruction that sets the STP bit to “1”.

4.3.4 Note on Return Operation from STOP/HALT Mode

The operation of returning from the STOP mode and HALT mode varies according to the interrupt level (ELEVEL) of the program status word (PSW), master interrupt enable flag (MIE), the contents of the interrupt enable register (IE0 to IE3), and whether the interrupt is a non-maskable interrupt or a maskable interrupt. For details of PSW and the IE and IRQ registers, see “nX-U8/100 Core Instruction Manual” and Chapter 5, “Interrupt”, respectively.

Table 4-1 and Table 4-2 show the return operations from STOP/HALT mode.

Table 4-1 Return Operation from STOP/HALT Mode (Non-Maskable Interrupt)

| ELEVEL | MIE | IEn.m | IRQn.m | Return operation from STOP/HALT mode |
|--------|-----|-------|--------|---|
| * | * | — | 0 | Not returned from STOP/HALT mode. |
| 3 | * | — | 1 | After the mode is returned from STOP/HALT mode, the program operation restarts from the instruction following the instruction that sets the STP/HLT bit to “1”. The program operation does not go to the interrupt routine. |
| 0,1,2 | * | — | 1 | After the mode is returned from the STOP/HALT mode, program operation restarts from the instruction following the instruction that sets the STP/HLT bit to “1”, then goes to the interrupt routine. |

Table 4-2 Return Operation from STOP/HALT Mode (Maskable Interrupt)

| ELEVEL | MIE | IEn.m | IRQn.m | Return operation from STOP/HALT mode |
|--------|-----|-------|--------|---|
| * | * | * | 0 | Not returned from STOP/HALT mode. |
| * | * | 0 | 1 | |
| * | 0 | 1 | 1 | After the mode is returned from STOP/HALT mode, the program operation restarts from the instruction following the instruction that sets the STP/HLT bit to “1”. The program operation does not go to the interrupt routine. |
| 2,3 | 1 | 1 | 1 | |
| 0,1 | 1 | 1 | 1 | After the mode is returned from the STOP/HALT mode, program operation restarts from the instruction following the instruction that sets the STP/HLT bit to “1”, then goes to the interrupt routine. |

Note:

- If the ELEVEL bit is 0H, it indicates that the CPU is performing neither non-maskable interrupt processing nor maskable interrupt processing nor software interrupt processing.
- If the ELEVEL bit is 1H, it indicates that the CPU is performing maskable interrupt processing or software interrupt processing. (ELEVEL is set during interrupt transition cycle.)
- If the ELEVEL bit is 2H, it indicates that the CPU is performing non-maskable interrupt processing. (ELEVEL is set during interrupt transition cycle.)
- If the ELEVEL bit is 3H, it indicates that the CPU is performing interrupt processing specific to the emulator. This setting is not allowed in normal applications.

4.3.5 Block Control Function

This LSI has a block control function, which resets and completely turns operating circuits of unused peripherals off to make even more reducing current consumption.

For each block control register, the initial value of each flag is "0", meaning the operation of each block is enabled. When any flag is set to "1" (Disable Operating), the function of the applicable block is reset and the clock supply to this block is stopped. When this flag is set to "1", the writing to all registers in the applicable block becomes invalid, and thus the reading from such register becomes the initial value. When using the function of the applicable block, ensure to reset the applicable flag of this block control register to "0" (enable operation).

- BLKCON0 register: Controls (enables/disables) the operation of the Timers 0, 1, 2, and 3 circuits.
- BLKCON1 register: Controls (enables/disables) the operation of the PWM0 and capture circuits.
- BLKCON2 register: Controls (enables/disables) the operation of the UART0, SSIO0, and SSIO1 circuits.
- BLKCON3 register: Controls (disables/enables) the operation of the melody driver 0 circuit.
- BLKCON4 register: Controls (disables/enables) the operation of the LCD driver and RC oscillation type A/D converter circuits.

Interrupts

5. Interrupts

5.1 Overview

This LSI has 21 interrupt sources (External interrupts: 6 sources, Internal interrupts: 15 sources) and a software interrupt (SWI).

For details of each interrupt, see the following chapters:

Chapter 7, "Time Base Counter"

Chapter 9, "Timer"

Chapter 10, "PWM"

Chapter 11, "Watchdog Timer"

Chapter 12, "Synchronous Serial Port"

Chapter 13, "UART"

Chapter 14, "Port 0"

Chapter 18, "Port 5"

Chapter 20, "Melody Driver"

Chapter 21, "RC Oscillation Type A/D Converter"

5.1.1 Features

- Non-maskable interrupt source: 1 (Internal sources: 1)
- Maskable interrupt sources: 27 (Internal sources: 14, External sources: 13)
- Software interrupt (SWI): maximum 64 sources
- External interrupts allow edge selection and sampling selection

5.2 Description of Registers

5.2.1 List of Registers

| Address | Name | Symbol (Byte) | Symbol (Word) | R/W | Size | Initial value |
|---------|------------------------------|---------------|---------------|-----|------|---------------|
| 0F011H | Interrupt enable register 1 | IE1 | — | R/W | 8 | 00H |
| 0F012H | Interrupt enable register 2 | IE2 | — | R/W | 8 | 00H |
| 0F013H | Interrupt enable register 3 | IE3 | — | R/W | 8 | 00H |
| 0F014H | Interrupt enable register 4 | IE4 | — | R/W | 8 | 00H |
| 0F015H | Interrupt enable register 5 | IE5 | — | R/W | 8 | 00H |
| 0F016H | Interrupt enable register 6 | IE6 | — | R/W | 8 | 00H |
| 0F017H | Interrupt enable register 7 | IE7 | — | R/W | 8 | 00H |
| 0F018H | Interrupt request register 0 | IRQ0 | — | R/W | 8 | 00H |
| 0F019H | Interrupt request register 1 | IRQ1 | — | R/W | 8 | 00H |
| 0F01AH | Interrupt request register 2 | IRQ2 | — | R/W | 8 | 00H |
| 0F01BH | Interrupt request register 3 | IRQ3 | — | R/W | 8 | 00H |
| 0F01CH | Interrupt request register 4 | IRQ4 | — | R/W | 8 | 00H |
| 0F01DH | Interrupt request register 5 | IRQ5 | — | R/W | 8 | 00H |
| 0F01EH | Interrupt request register 6 | IRQ6 | — | R/W | 8 | 00H |
| 0F01FH | Interrupt request register 7 | IRQ7 | — | R/W | 8 | 00H |

5.2.2 Interrupt Enable Register 1 (IE1)

Address: 0F011H
Access: R/W
Access size: 8-bit
Initial value: 00H

| | | | | | | | | |
|---------------|-----|-----|-----|------|------|------|------|------|
| | 7 | 6 | 5 | 4 | 3 | 2 | 1 | 0 |
| IE1 | — | — | — | EP04 | EP03 | EP02 | EP01 | EP00 |
| R/W | R/W | R/W | R/W | R/W | R/W | R/W | R/W | R/W |
| Initial value | 0 | 0 | 0 | 0 | 0 | 0 | 0 | 0 |

IE1 is a special function register (SFR) to control enable/disable for each interrupt request. When an interrupt is accepted, the master interrupt enable flag (MIE) is set to "0", but the corresponding flag of IE1 is not reset.

[Description of Bits]

- **EP00** (bit 0)
EP00 is the enable flag for the input port P00 pin interrupt (P00INT).

| EP00 | Description |
|------|--------------------------|
| 0 | Disabled (initial value) |
| 1 | Enabled |

- **EP01** (bit 1)
EP01 is the enable flag for the input port P01 pin interrupt (P01INT).

| EP01 | Description |
|------|--------------------------|
| 0 | Disabled (initial value) |
| 1 | Enabled |

- **EP02** (bit 2)
EP02 is the enable flag for the input port P02 pin interrupt (P02INT).

| EP02 | Description |
|------|--------------------------|
| 0 | Disabled (initial value) |
| 1 | Enabled |

- **EP03** (bit 3)
EP03 is the enable flag for the input port P03 pin interrupt (P03INT).

| EP03 | Description |
|------|--------------------------|
| 0 | Disabled (initial value) |
| 1 | Enabled |

- **EP04** (bit 4)
EP04 is the enable flag for the input port P04 pin interrupt (P04INT).

| EP04 | Description |
|------|--------------------------|
| 0 | Disabled (initial value) |
| 1 | Enabled |

5.2.3 Interrupt Enable Register 2 (IE2)

Address: 0F012H
 Access: R/W
 Access size: 8-bit
 Initial value: 00H

| | | | | | | | | |
|---------------|-----|-----|-----|-----|-----|-----|-------|-------|
| | 7 | 6 | 5 | 4 | 3 | 2 | 1 | 0 |
| IE2 | — | — | — | — | EP5 | — | ESIO1 | ESIO0 |
| R/W | R/W | R/W | R/W | R/W | R/W | R/W | R/W | R/W |
| Initial value | 0 | 0 | 0 | 0 | 0 | 0 | 0 | 0 |

IE2 is a special function register (SFR) to control enable/disable for each interrupt request. When an interrupt is accepted, the master interrupt enable flag (MIE) is set to “0”, but the corresponding flag of IE2 is not reset.

[Description of Bits]

- **ESIO0** (bit 0)
 ESIO0 is the enable flag for the synchronous serial port 0 interrupt (SIO0INT).

| ESIO0 | Description |
|-------|--------------------------|
| 0 | Disabled (initial value) |
| 1 | Enabled |

- **ESIO1** (bit 1)
 ESIO1 is the enable flag for the synchronous serial port 1 interrupt (SIO1INT).

| ESIO1 | Description |
|-------|--------------------------|
| 0 | Disabled (initial value) |
| 1 | Enabled |

- **EP5** (bit 3)
 EP5 is the enable flag for the external 8 interrupt (P5INT).

| EP5 | Description |
|-----|--------------------------|
| 0 | Disabled (initial value) |
| 1 | Enabled |

5.2.4 Interrupt Enable Register 3 (IE3)

Address: 0F013H
 Access: R/W
 Access size: 8-bit
 Initial value: 00H

| | | | | | | | | |
|---------------|-----|-----|-----|-----|-----|-----|------|------|
| | 7 | 6 | 5 | 4 | 3 | 2 | 1 | 0 |
| IE3 | — | — | — | — | — | — | ETM1 | ETM0 |
| R/W | R/W | R/W | R/W | R/W | R/W | R/W | R/W | R/W |
| Initial value | 0 | 0 | 0 | 0 | 0 | 0 | 0 | 0 |

IE3 is a special function register (SFR) to control enable/disable for each interrupt request. When an interrupt is accepted, the master interrupt enable flag (MIE) is set to “0”, but the corresponding flag of IE3 is not reset.

[Description of Bits]

- **ETM0** (bit 0)
 ETM0 is the enable flag for the timer 0 interrupt (TM0INT).

| ETM0 | Description |
|------|--------------------------|
| 0 | Disabled (initial value) |
| 1 | Enabled |

- **ETM1** (bit 1)
 ETM1 is the enable flag for the timer 1 interrupt (TM1INT).

| ETM1 | Description |
|------|--------------------------|
| 0 | Disabled (initial value) |
| 1 | Enabled |

5.2.5 Interrupt Enable Register 4 (IE4)

Address: 0F014H
 Access: R/W
 Access size: 8-bit
 Initial value: 00H

| | | | | | | | | |
|---------------|-----|-----|------|-----|-----|------|-----|------|
| | 7 | 6 | 5 | 4 | 3 | 2 | 1 | 0 |
| IE4 | — | — | ERAD | — | — | EMD0 | — | EUA0 |
| R/W | R/W | R/W | R/W | R/W | R/W | R/W | R/W | R/W |
| Initial value | 0 | 0 | 0 | 0 | 0 | 0 | 0 | 0 |

IE4 is a special function register (SFR) to control enable/disable for each interrupt request. When an interrupt is accepted, the master interrupt enable flag (MIE) is set to “0”, but the corresponding flag of IE4 is not reset.

[Description of Bits]

- **EUA0** (bit 0)
 EUA0 is the enable flag for the UART0 interrupt (UA0INT).

| EUA0 | Description |
|------|--------------------------|
| 0 | Disabled (initial value) |
| 1 | Enabled |

- **EMD0** (bit 2)
 EMD0 is the enable flag for the melody 0 interrupt (MD0INT).

| EMD0 | Description |
|------|--------------------------|
| 0 | Disabled (initial value) |
| 1 | Enabled |

- **ERAD** (bit 5)
 ERAD is the enable flag for the RC oscillation type A/D converter interrupt (RADINT).

| ERA0 | Description |
|------|--------------------------|
| 0 | Disabled (initial value) |
| 1 | Enabled |

5.2.6 Interrupt Enable Register 5 (IE5)

Address: 0F015H
 Access: R/W
 Access size: 8-bit
 Initial value: 00H

| | | | | | | | | |
|---------------|-----|-----|------|------|-----|-----|-----|-----|
| | 7 | 6 | 5 | 4 | 3 | 2 | 1 | 0 |
| IE5 | — | — | ETM3 | ETM2 | — | — | — | — |
| R/W | R/W | R/W | R/W | R/W | R/W | R/W | R/W | R/W |
| Initial value | 0 | 0 | 0 | 0 | 0 | 0 | 0 | 0 |

IE5 is a special function register (SFR) to control enable/disable for each interrupt request. When an interrupt is accepted, the master interrupt enable flag (MIE) is set to “0”, but the corresponding flag of IE5 is not reset.

[Description of Bits]

- **ETM2** (bit 4)
 ETM2 is the enable flag for the timer 2 interrupt (TM2INT).

| ETM2 | Description |
|------|--------------------------|
| 0 | Disabled (initial value) |
| 1 | Enabled |

- **ETM3** (bit 5)
 ETM3 is the enable flag for the timer 3 interrupt (TM3INT).

| ETM3 | Description |
|------|--------------------------|
| 0 | Disabled (initial value) |
| 1 | Enabled |

5.2.7 Interrupt Enable Register 6 (IE6)

Address: 0F016H
 Access: R/W
 Access size: 8-bit
 Initial value: 00H

| | | | | | | | | |
|---------------|------|-----|-------|-----|-----|-----|-----|------|
| | 7 | 6 | 5 | 4 | 3 | 2 | 1 | 0 |
| IE6 | E32H | — | E128H | — | — | — | — | EPW0 |
| R/W | R/W | R/W | R/W | R/W | R/W | R/W | R/W | R/W |
| Initial value | 0 | 0 | 0 | 0 | 0 | 0 | 0 | 0 |

IE6 is a special function register (SFR) to control enable/disable for each interrupt request. When an interrupt is accepted, the master interrupt enable flag (MIE) is set to "0", but the corresponding flag of IE6 is not reset.

[Description of Bits]

- **EPW0** (bit 0)
 EPW0 is the enable flag for the PWM0 interrupt (PW0INT).

| EPW0 | Description |
|------|--------------------------|
| 0 | Disabled (initial value) |
| 1 | Enabled |

- **E128H** (bit 5)
 E128H is the enable flag for the time base counter 128 Hz interrupt (T128HINT).

| E128H | Description |
|-------|--------------------------|
| 0 | Disabled (initial value) |
| 1 | Enabled |

- **E32H** (bit 7)
 E32H is the enable flag for the time base counter 32 Hz interrupt (T32HINT).

| E32H | Description |
|------|--------------------------|
| 0 | Disabled (initial value) |
| 1 | Enabled |

5.2.8 Interrupt Enable Register 7 (IE7)

Address: 0F017H

Access: R/W

Access size: 8-bit

Initial value: 00H

| | | | | | | | | |
|---------------|-----|-----|-----|-----|-----|-----|-----|------|
| | 7 | 6 | 5 | 4 | 3 | 2 | 1 | 0 |
| IE7 | — | — | — | — | E2H | — | — | E16H |
| R/W | R/W | R/W | R/W | R/W | R/W | R/W | R/W | R/W |
| Initial value | 0 | 0 | 0 | 0 | 0 | 0 | 0 | 0 |

IE7 is a special function register (SFR) to control enable/disable for each interrupt request.

When an interrupt is accepted, the master interrupt enable flag (MIE) is set to "0", but the corresponding flag of IE7 is not reset.

[Description of Bits]

- **E16H** (bit 0)
E16H is the enable flag for the time base counter 16 Hz interrupt (T16HINT).

| E16H | Description |
|------|--------------------------|
| 0 | Disabled (initial value) |
| 1 | Enabled |

- **E2H** (bit 3)
E2H is the enable flag for the time base counter 2 Hz interrupt (T2HINT).

| E2H | Description |
|-----|--------------------------|
| 0 | Disabled (initial value) |
| 1 | Enabled |

5.2.9 Interrupt Request Register 0 (IRQ0)

Address: 0F018H
 Access: R/W
 Access size: 8-bit
 Initial value: 00H

| | | | | | | | | |
|---------------|-----|-----|-----|-----|-----|-----|-----|------|
| | 7 | 6 | 5 | 4 | 3 | 2 | 1 | 0 |
| IRQ0 | — | — | — | — | — | — | — | QWDT |
| R/W | R/W | R/W | R/W | R/W | R/W | R/W | R/W | R/W |
| Initial value | 0 | 0 | 0 | 0 | 0 | 0 | 0 | 0 |

IRQ0 is a special function register (SFR) to request an interrupt for each interrupt source.

The watchdog timer interrupt (WDTINT) is a non-maskable interrupt that do not depend on MIE. In this case, an interrupt is requested to the CPU regardless of the value of the Mask Interrupt Enable flag (MIE).

Each IRQ0 request flag is set to “1” regardless of the MIE value when an interrupt is generated. By setting the IRQ0 request flag to “1” by software, an interrupt can be generated.

The corresponding flag of IRQ0 is set to “0” by hardware when the interrupt request is accepted by the CPU.

[Description of Bits]

- **QWDT** (bit 0)
 QWDT is the request flag for the watchdog timer interrupt (WDTINT).

| QWDT | Description |
|------|----------------------------|
| 0 | No request (initial value) |
| 1 | Request |

Note:

When an interrupt is generated by the write instruction to the interrupt request register (IRQ0), the interrupt shift cycle starts after the next 1 instruction is executed.

5.2.10 Interrupt Request Register 1 (IRQ1)

Address: 0F019H
Access: R/W
Access size: 8-bit
Initial value: 00H

| | | | | | | | | |
|---------------|-----|-----|-----|------|------|------|------|------|
| | 7 | 6 | 5 | 4 | 3 | 2 | 1 | 0 |
| IRQ1 | — | — | — | QP04 | QP03 | QP02 | QP01 | QP00 |
| R/W | R/W | R/W | R/W | R/W | R/W | R/W | R/W | R/W |
| Initial value | 0 | 0 | 0 | 0 | 0 | 0 | 0 | 0 |

IRQ1 is a special function register (SFR) to request an interrupt for each interrupt source.

Each IRQ1 request flag is set to “1” regardless of the IE1 and MIE values when an interrupt is generated. In this case, an interrupt is requested to the CPU when the related flag of the interrupt enable register (IE1) is set to “1” and the master interrupt enable flag (MIE) is set to “1”.

By setting the IRQ1 request flag to “1” by software, an interrupt can be generated.

The corresponding flag of IRQ1 is set to “0” by hardware when the interrupt request is accepted by the CPU.

[Description of Bits]

- **QP00** (bit 0)
QP00 is the request flag for the input port P00 pin interrupt (P00INT).

| QP00 | Description |
|------|----------------------------|
| 0 | No request (initial value) |
| 1 | Request |

- **QP01** (bit 1)
QP01 is the request flag for the input port P01 pin interrupt (P01INT).

| QP01 | Description |
|------|----------------------------|
| 0 | No request (initial value) |
| 1 | Request |

- **QP02** (bit 2)
QP02 is the request flag for the input port P02 pin interrupt (P02INT).

| QP02 | Description |
|------|----------------------------|
| 0 | No request (initial value) |
| 1 | Request |

- **QP03** (bit 3)
QP03 is the request flag for the input port P03 pin interrupt (P03INT).

| QP03 | Description |
|------|----------------------------|
| 0 | No request (initial value) |
| 1 | Request |

- **QP04** (bit 4)
QP04 is the request flag for the input port P04 pin interrupt (P04INT).

| QP04 | Description |
|------|----------------------------|
| 0 | No request (initial value) |
| 1 | Request |

Note:

When an interrupt is generated by the write instruction to the interrupt request register (IRQ1) or to the interrupt enable register (IE1), the interrupt shift cycle starts after the next 1 instruction is executed.

5.2.11 Interrupt Request Register 2 (IRQ2)

Address: 0F01AH
 Access: R/W
 Access size: 8-bit
 Initial value: 00H

| | | | | | | | | |
|---------------|-----|-----|-----|-----|-----|-----|-------|-------|
| | 7 | 6 | 5 | 4 | 3 | 2 | 1 | 0 |
| IRQ2 | — | — | — | — | QP5 | — | QSIO1 | QSIO0 |
| R/W | R/W | R/W | R/W | R/W | R/W | R/W | R/W | R/W |
| Initial value | 0 | 0 | 0 | 0 | 0 | 0 | 0 | 0 |

IRQ2 is a special function register (SFR) to request an interrupt for each interrupt source.

Each IRQ2 request flag is set to “1” regardless of the IE2 and MIE values when an interrupt is generated. In this case, an interrupt is requested to the CPU when the related flag of the interrupt enable register (IE2) is set to “1” and the master interrupt enable flag (MIE) is set to “1”.

By setting the IRQ2 request flag to “1” by software, an interrupt can be generated.

The corresponding flag of IRQ2 is set to “0” by hardware when the interrupt request is accepted by the CPU.

[Description of Bits]

- **QSIO0** (bit 0)
 QSIO0 is the request flag for the synchronous serial port 0 interrupt (SIO0INT).

| QSIO0 | Description |
|-------|----------------------------|
| 0 | No request (initial value) |
| 1 | Request |

- **QSIO1** (bit 1)
 QSIO1 is the request flag for the synchronous serial port 1 interrupt (SIO1INT).

| QSIO0 | Description |
|-------|----------------------------|
| 0 | No request (initial value) |
| 1 | Request |

- **QP5** (bit 3)
 QP5 is the request flag for the external 8 interrupt (P5INT).

| QP5 | Description |
|-----|----------------------------|
| 0 | No request (initial value) |
| 1 | Request |

Note:

When an interrupt is generated by the write instruction to the interrupt request register (IRQ2) or to the interrupt enable register (IE2), the interrupt shift cycle starts after the next 1 instruction is executed.

5.2.12 Interrupt Request Register 3 (IRQ3)

Address: 0F01BH
Access: R/W
Access size: 8-bit
Initial value: 00H

| | | | | | | | | |
|---------------|-----|-----|-----|-----|-----|-----|------|------|
| | 7 | 6 | 5 | 4 | 3 | 2 | 1 | 0 |
| IRQ3 | — | — | — | — | — | — | QTM1 | QTM0 |
| R/W | R/W | R/W | R/W | R/W | R/W | R/W | R/W | R/W |
| Initial value | 0 | 0 | 0 | 0 | 0 | 0 | 0 | 0 |

IRQ3 is a special function register (SFR) to request an interrupt for each interrupt source.

Each IRQ3 request flag is set to “1” regardless of the IE3 and MIE values when an interrupt is generated. In this case, an interrupt is requested to the CPU when the related flag of the interrupt enable register (IE3) is set to “1” and the master interrupt enable flag (MIE) is set to “1”.

By setting the IRQ3 request flag to “1” by software, an interrupt can be generated.

The corresponding flag of IRQ3 is set to “0” by hardware when the interrupt request is accepted by the CPU.

[Description of Bits]

- **QTM0** (bit 0)
QTM0 is the request flag for the timer 0 interrupt (TM0INT).

| QTM0 | Description |
|------|----------------------------|
| 0 | No request (initial value) |
| 1 | Request |

- **QTM1** (bit 1)
QTM1 is the request flag for the timer 1 interrupt (TM1INT).

| QTM1 | Description |
|------|----------------------------|
| 0 | No request (initial value) |
| 1 | Request |

Note:

When an interrupt is generated by the write instruction to the interrupt request register (IRQ3) or to the interrupt enable register (IE3), the interrupt shift cycle starts after the next 1 instruction is executed.

5.2.13 Interrupt Request Register 4 (IRQ4)

Address: 0F01CH
 Access: R/W
 Access size: 8-bit
 Initial value: 00H

| | | | | | | | | |
|---------------|-----|-----|------|-----|-----|------|-----|------|
| | 7 | 6 | 5 | 4 | 3 | 2 | 1 | 0 |
| IRQ4 | — | — | QRAD | — | — | QMD0 | — | QUA0 |
| R/W | R/W | R/W | R/W | R/W | R/W | R/W | R/W | R/W |
| Initial value | 0 | 0 | 0 | 0 | 0 | 0 | 0 | 0 |

IRQ4 is a special function register (SFR) to request an interrupt for each interrupt source.

Each IRQ4 request flag is set to “1” regardless of the IE4 and MIE values when an interrupt is generated. In this case, an interrupt is requested to the CPU when the related flag of the interrupt enable register (IE4) is set to “1” and the master interrupt enable flag (MIE) is set to “1”.

By setting the IRQ4 request flag to “1” by software, an interrupt can be generated.

The corresponding flag of IRQ4 is set to “0” by hardware when the interrupt request is accepted by the CPU.

[Description of Bits]

- **QUA0** (bit 0)
 QUA0 is the request flag for the UART0 interrupt (UA0INT).

| QUA0 | Description |
|------|----------------------------|
| 0 | No request (initial value) |
| 1 | Request |

- **QMD0** (bit 2)
 QMD0 is the request flag for the melody 0 interrupt (MD0INT).

| QMD0 | Description |
|------|----------------------------|
| 0 | No request (initial value) |
| 1 | Request |

- **QRA0** (bit 5)
 QMD0 is the request flag for the RC oscillation type A/D converter interrupt (RADINT).

| QRA0 | Description |
|------|----------------------------|
| 0 | No request (initial value) |
| 1 | Request |

Note:

When an interrupt is generated by the write instruction to the interrupt request register (IRQ4) or to the interrupt enable register (IE4), the interrupt shift cycle starts after the next 1 instruction is executed.

5.2.14 Interrupt Request Register 5 (IRQ5)

Address: 0F01DH
Access: R/W
Access size: 8-bit
Initial value: 00H

| | | | | | | | | |
|---------------|-----|-----|------|------|-----|-----|-----|-----|
| | 7 | 6 | 5 | 4 | 3 | 2 | 1 | 0 |
| IRQ3 | — | — | QTM3 | QTM2 | — | — | — | — |
| R/W | R/W | R/W | R/W | R/W | R/W | R/W | R/W | R/W |
| Initial value | 0 | 0 | 0 | 0 | 0 | 0 | 0 | 0 |

IRQ5 is a special function register (SFR) to request an interrupt for each interrupt source.

Each IRQ5 request flag is set to “1” regardless of the IE3 and MIE values when an interrupt is generated. In this case, an interrupt is requested to the CPU when the related flag of the interrupt enable register (IE5) is set to “1” and the master interrupt enable flag (MIE) is set to “1”.

By setting the IRQ5 request flag to “1” by software, an interrupt can be generated.

The corresponding flag of IRQ5 is set to “0” by hardware when the interrupt request is accepted by the CPU.

[Description of Bits]

- **QTM2 (bit 4)**
QTM2 is the request flag for the timer 2 interrupt (TM2INT).

| QTM2 | Description |
|------|----------------------------|
| 0 | No request (initial value) |
| 1 | Request |

- **QTM3 (bit 5)**
QTM3 is the request flag for the timer 3 interrupt (TM3INT).

| QTM3 | Description |
|------|----------------------------|
| 0 | No request (initial value) |
| 1 | Request |

Note:

When an interrupt is generated by the write instruction to the interrupt request register (IRQ5) or to the interrupt enable register (IE5), the interrupt shift cycle starts after the next 1 instruction is executed.

5.2.15 Interrupt Request Register 6 (IRQ6)

Address: 0F01EH
 Access: R/W
 Access size: 8-bit
 Initial value: 00H

| | | | | | | | | |
|---------------|------|-----|-------|-----|-----|-----|-----|------|
| | 7 | 6 | 5 | 4 | 3 | 2 | 1 | 0 |
| IRQ6 | Q32H | — | Q128H | — | — | — | — | QPW0 |
| R/W | R/W | R/W | R/W | R/W | R/W | R/W | R/W | R/W |
| Initial value | 0 | 0 | 0 | 0 | 0 | 0 | 0 | 0 |

IRQ6 is a special function register (SFR) to request an interrupt for each interrupt source.

Each IRQ6 request flag is set to “1” regardless of the IE6 and MIE values when an interrupt is generated. In this case, an interrupt is requested to the CPU when the related flag of the interrupt enable register (IE6) is set to “1” and the master interrupt enable flag (MIE) is set to “1”.

By setting the IRQ6 request flag to “1” by software, an interrupt can be generated.

The corresponding flag of IRQ6 is set to “0” by hardware when the interrupt request is accepted by the CPU.

[Description of Bits]

- **QPW0** (bit 0)
 QPW0 is the request flag for the PWM0 interrupt (PW0INT).

| QPW0 | Description |
|------|----------------------------|
| 0 | No request (initial value) |
| 1 | Request |

- **Q128H** (bit 5)
 Q128H is the request flag for the time base counter 128 Hz interrupt (T128HINT).

| Q128H | Description |
|-------|----------------------------|
| 0 | No request (initial value) |
| 1 | Request |

- **Q32H** (bit 7)
 Q32H is the request flag for the time base counter 32 Hz interrupt (T32HINT).

| Q32H | Description |
|------|----------------------------|
| 0 | No request (initial value) |
| 1 | Request |

Note:

When an interrupt is generated by the write instruction to the interrupt request register (IRQ6) or to the interrupt enable register (IE6), the interrupt shift cycle starts after the next 1 instruction is executed.

5.2.16 Interrupt Request Register 7 (IRQ7)

Address: 0F01FH
Access: R/W
Access size: 8-bit
Initial value: 00H

| | | | | | | | | |
|---------------|-----|-----|-----|-----|-----|-----|-----|------|
| | 7 | 6 | 5 | 4 | 3 | 2 | 1 | 0 |
| IRQ7 | — | — | — | — | Q2H | — | — | Q16H |
| R/W | R/W | R/W | R/W | R/W | R/W | R/W | R/W | R/W |
| Initial value | 0 | 0 | 0 | 0 | 0 | 0 | 0 | 0 |

IRQ7 is a special function register (SFR) to request an interrupt for each interrupt source.

Each IRQ7 request flag is set to “1” regardless of the IE7 and MIE values when an interrupt is generated. In this case, an interrupt is requested to the CPU when the related flag of the interrupt enable register (IE7) is set to “1” and the master interrupt enable flag (MIE) is set to “1”.

By setting the IRQ7 request flag to “1” by software, an interrupt can be generated.

The corresponding flag of IRQ7 is set to “0” by hardware when the interrupt request is accepted by the CPU.

[Description of Bits]

- **Q16H** (bit 0)
Q16H is the request flag for the time base counter 8 Hz interrupt (T8HINT).

| Q16H | Description |
|------|----------------------------|
| 0 | No request (initial value) |
| 1 | Request |

- **Q2H** (bit 3)
Q2H is the request flag for the time base counter 2 Hz interrupt (T2HINT).

| Q2H | Description |
|-----|----------------------------|
| 0 | No request (initial value) |
| 1 | Request |

Note:

When an interrupt is generated by the write instruction to the interrupt request register (IRQ7) or to the interrupt enable register (IE7), the interrupt shift cycle starts after the next 1 instruction is executed.

5.3 Description of Operation

With the exception of the watchdog timer interrupt (WDTINT), interrupt enable/disable for 20 sources is controlled by the master interrupt enable flag (MIE) and the individual interrupt enable registers (IE1 to 7). WDTINT is a non-maskable interrupt.

When the interrupt conditions are satisfied, the CPU calls a branching destination address from the vector table determined for each interrupt source and the interrupt shift cycle starts to branch to the interrupt processing routine.

Table 5-1 lists the interrupt sources.

Table 5-1 Interrupt Sources

| Priority | Interrupt source | Symbol | Vector table address |
|----------|---|----------|----------------------|
| 1 | Watchdog timer interrupt | WDTINT | 0008H |
| 2 | P00 interrupt | P00INT | 0010H |
| 3 | P01 interrupt | P01INT | 0012H |
| 4 | P02 interrupt | P02INT | 0014H |
| 5 | P03 interrupt | P03INT | 0016H |
| 6 | P04 interrupt | P04INT | 0018H |
| 7 | Synchronous serial port 0 interrupt | SIO0INT | 0020H |
| 8 | Synchronous serial port 1 interrupt | SIO1INT | 0022H |
| 9 | External 8 interrupt | P5INT | 0026H |
| 10 | Timer 0 interrupt | TM0INT | 0030H |
| 11 | Timer 1 interrupt | TM1INT | 0032H |
| 12 | UART 0 interrupt | UA0INT | 0040H |
| 13 | Melody 0 interrupt | MD0INT | 0044H |
| 14 | RC oscillation type A/D converter interrupt | RADINT | 004AH |
| 15 | Timer 2 interrupt | TM2INT | 0058H |
| 16 | Timer 3 interrupt | TM3INT | 005AH |
| 17 | PWM0 interrupt | PW0INT | 0060H |
| 18 | TBC128Hz interrupt | T128HINT | 006AH |
| 19 | TBC32Hz interrupt | T32HINT | 006EH |
| 20 | TBC16Hz interrupt | T16HINT | 0070H |
| 21 | TBC2Hz interrupt | T2HINT | 0076H |

Note:

- When multiple interrupts are generated concurrently, the interrupts are serviced according to this priority and processing of low-priority interrupts is pending.
- Please define vector tables for all unused interrupts for fail safe.

5.3.1 Maskable Interrupt Processing

When an interrupt is generated with the MIE flag set to “1”, the following processing is executed by hardware and the processing of program shifts to the interrupt destination.

- (1) Transfer the program counter (PC) to ELR1
- (2) Transfer CSR to ECSR1
- (3) Transfer PSW to EPSW1
- (4) Set the MIE flag to “0”
- (5) Set the ELEVEL field to “1”
- (6) Load the interrupt start address into PC

5.3.2 Non-Maskable Interrupt Processing

When an interrupt is generated regardless of the state of MIE flag, the following processing is performed by hardware and the processing of program shifts to the interrupt destination.

- (1) Transfer PC to ELR2
- (2) Transfer CSR to ECSR2
- (3) Transfer PSW to EPSW2
- (4) Set the ELEVEL field to “2”
- (5) Load the interrupt start address into PC

5.3.3 Software Interrupt Processing

A software interrupt is generated as required within an application program. When the SWI instruction is performed within the program, a software interrupt is generated, the following processing is performed by hardware, and the processing program shifts to the interrupt destination. The vector table is specified by the SWI instruction.

- (1) Transfer PC to ELR1
- (2) Transfer CSR to ECSR1
- (3) Transfer PSW to EPSW1
- (4) Set the MIE flag to “0”
- (5) Set the ELEVEL field to “1”
- (6) Load the interrupt start address into PC

Reference:

For the MIE flag, Program Counter (PC), CSR, PSW, and ELEVEL, see “nX-U8/100 Core Instruction Manual”.

5.3.4 Notes on Interrupt Routine

Notes are different in programming depending on whether a subroutine is called or not by the program in executing an interrupt routine, whether multiple interrupts are enabled or disabled, and whether such interrupts are maskable or non-maskable.

Status A: Maskable interrupt is being processed

A-1: When a subroutine is not called by the program in executing an interrupt routine

A-1-1: When multiple interrupts are disabled

- Processing immediately after the start of interrupt routine execution
 No specific notes.

- Processing at the end of interrupt routine execution

Specify the RTI instruction to return the contents of the ELR register to the PC and those of the EPSW register to PSW.

A-1-2: When multiple interrupts are enabled

- Processing immediately after the start of interrupt routine execution

Specify "PUSH ELR, EPSW" to save the interrupt return address and the PSW status in the stack.

- Processing before the master interrupt enable(MIE) bit is set

Specify "RB Exx" to invalidate the accepted interrupt. (Exx: the accepted interrupt enable flag)

- Processing at the end of interrupt routine execution

Specify "DI" not to execute the same interrupt routine.

Specify "SB Exx" to validate the accepted interrupt. (Exx: the accepted interrupt enable flag)

Specify "POP PC, PSW" instead of the RTI instruction to return the contents of the stack to PC and PSW.

Example of description:
 Status A-1-1

```
Intrpt_A-1-1; ; A-1-1 state
DI ; Disable interrupt
:
:
:
RTI ; Return PC from ELR
; Return PSW form
EPSW
; End
```

Example of description: Status
 A-1-2

```
Intrpt_A-1-2; ; Start
PUSH LR,EPSW ; Save ELR and EPSW at the
beginning
:
RB Exx ; Invalidate the accepted interrupt
(*1)
EI ; Enable interrupt (*2)
:
:
DI ; Disable interrupt
SB Exx ; Validate the accepted interrupt
POP PC,PSW ; Return PC from the stack
; Return PSW from the stack
; End
```

(*1) When multiple interrupts are enabled, please set the accepted interrupt enable flag to "0" to prevent the occurrence of the accepted interrupt.

(*2) After enabling interrupt, not only a higher-priority interrupt than the accepted interrupt but also a lower-priority interrupt than that occurs.

A-2: When a subroutine is called by the program in executing an interrupt routine

A-2-1: When multiple interrupts are disabled

- Processing immediately after the start of interrupt routine execution
Specify the "PUSH LR" instruction to save the subroutine return address in the stack.
- Processing at the end of interrupt routine execution
Specify "POP LR" immediately before the RTI instruction to return from the interrupt processing after returning the subroutine return address to LR.

A-2-2: When multiple interrupts are enabled

- Processing immediately after the start of interrupt routine execution
Specify "PUSH LR, ELR, EPSW" to save the interrupt return address, the subroutine return address, and the EPSW status in the stack.
- Processing before the master interrupt enable(MIE) bit is set
Specify "RB Exx" to invalidate the accepted interrupt. (Exx: the accepted interrupt enable flag)
- Processing at the end of interrupt routine execution
Specify "DI" not to execute the same interrupt routine.
Specify "SB Exx" to validate the accepted interrupt. (Exx: the accepted interrupt enable flag)
Specify "POP PC, PSW, LR" instead of the RTI instruction to return the saved data of the interrupt return address to PC, the saved data of EPSW to PSW, and the saved data of LR to LR.

Example of description: Status A-2-2

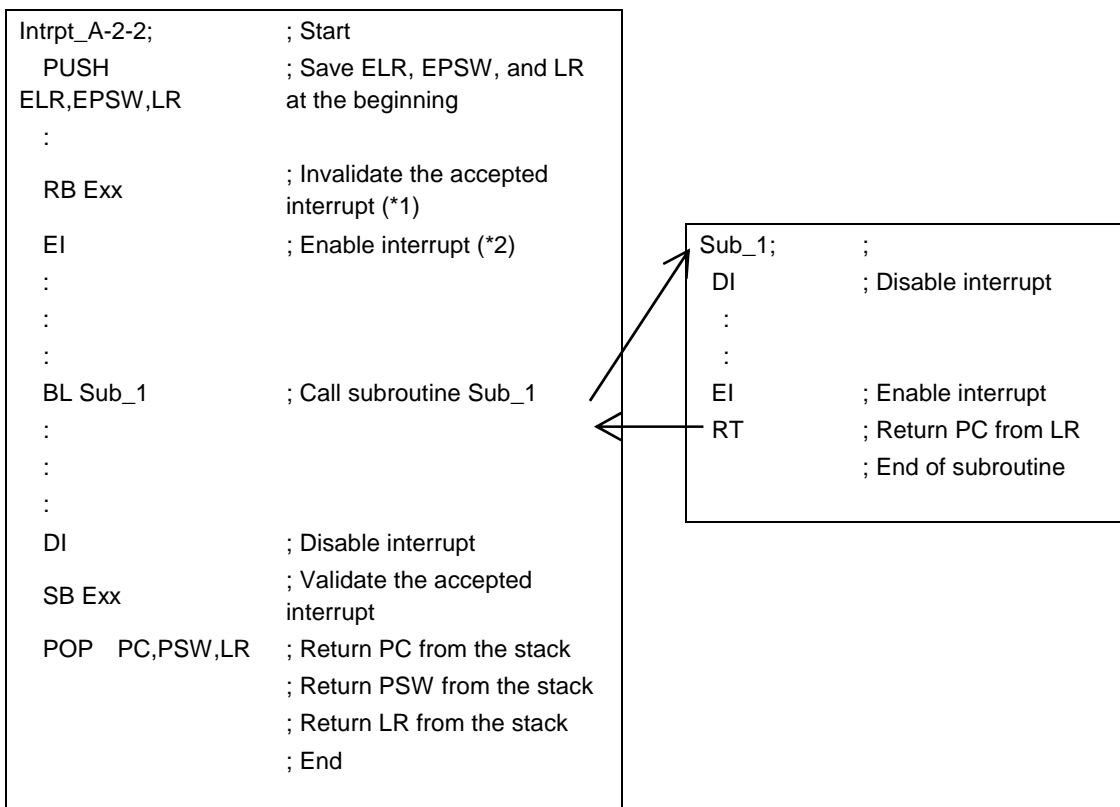

(*1) When multiple interrupts are enabled, please set the accepted interrupt enable flag to "0" to prevent the occurrence of the accepted interrupt.

(*2) After enabling interrupt, not only a higher-priority interrupt than the accepted interrupt but also a lower-priority interrupt than that occurs.

Status B: Non-maskable interrupt is being processed

B-1: When a subroutine is not called in an interrupt routine

- Processing immediately after the start of interrupt routine execution
 Specify "PUSH ELR, EPSW" to save the interrupt return address and the PSW status in the stack.
- Interrupt routine execution end processing
 Specify "POP PSW, PC" to return the contents of the stack to PC and PSW.

Example of description: Status B-1

```

Intrpt_C-1:      ; Start the interrupt routine
  PUSH  ELR,EP SW ; Save ELR and EPSW at the
                  ; beginning
  :
  :
  POP   PSW,PC   ; Return PC from the stack
                  ; Return PSW from the stack
                  ; Return LR from the stack
                  ; End the interrupt routine
    
```

B-2: When a subroutine is called in an interrupt routine

- Processing immediately after the start of interrupt routine
 Specify "PUSH ELR, LR, EPSW" to save the interrupt return address, the subroutine return address, and the EPSW status in the stack.
- Interrupt routine end processing
 Specify "POP PSW, PC, LR" to return the saved data of the interrupt return address to PC, the saved data of EPSW to PSW, and the saved data of LR to LR.

Example of description: Status B-2

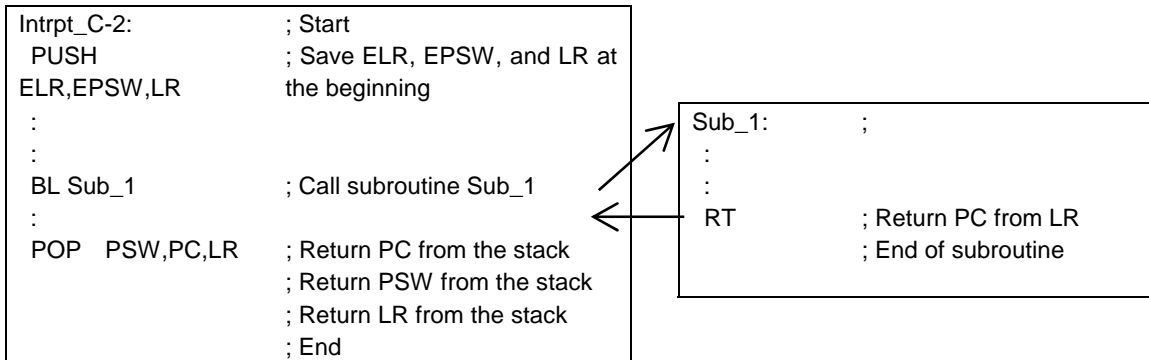

5.3.5 Interrupt Disable State

Even if the interrupt conditions are satisfied, an interrupt may not be accepted depending on the operating state. This is called an interrupt disabled state. See below for the interrupt disabled state and the handling of interrupts in this state.

Interrupt disabled state 1: Between the interrupt shift cycle and the instruction at the beginning of the interrupt routine
When the interrupt conditions are satisfied in this section, an interrupt is generated immediately following the execution of the instruction at the beginning of the interrupt routine corresponding to the interrupt that has already been enabled.

Interrupt disabled state 2: Between the DSR prefix instruction and the next instruction
When the interrupt conditions are satisfied in this section, an interrupt is generated immediately after execution of the instruction following the DSR prefix instruction.

For the DSR prefix instruction, see “nX-U8/100 Core Instruction Manual”.

Clock Generation Circuit

6. Clock Generation Circuit

6.1 Overview

The clock generation circuit generates and provides a low-speed clock (LSCLK), the low-speed double clock (LSCLK x 2), a high-speed clock (HSCLK), a system clock (SYSCLK), and a high-speed output clock (OUTCLK). LSCLK, LSCLK x 2, and HSCLK are time base clocks for the peripheral circuits, SYSCLK is a basic operation clock of CPU, and OUTCLK is a clock that is output from a port.

For the OUTCLK output port, see Chapter 15, "Port 2".

For the STOP mode described in this chapter, see Chapter 4, "MCU Control Function."

6.1.1 Features

- Low-Speed Clock Generation Circuit: 32.768kHz crystal oscillation mode
 - Capable of using the 32.768kHz double clock LSCLK x 2 (64kHz) for some peripherals
- High-speed clock generation circuit
 - 500kHz/2MHz RC oscillation mode
 - 500kHz or 2MHz RC oscillation

6.1.2 Configuration

Figure 6-1 shows the configuration of the clock generation circuit.

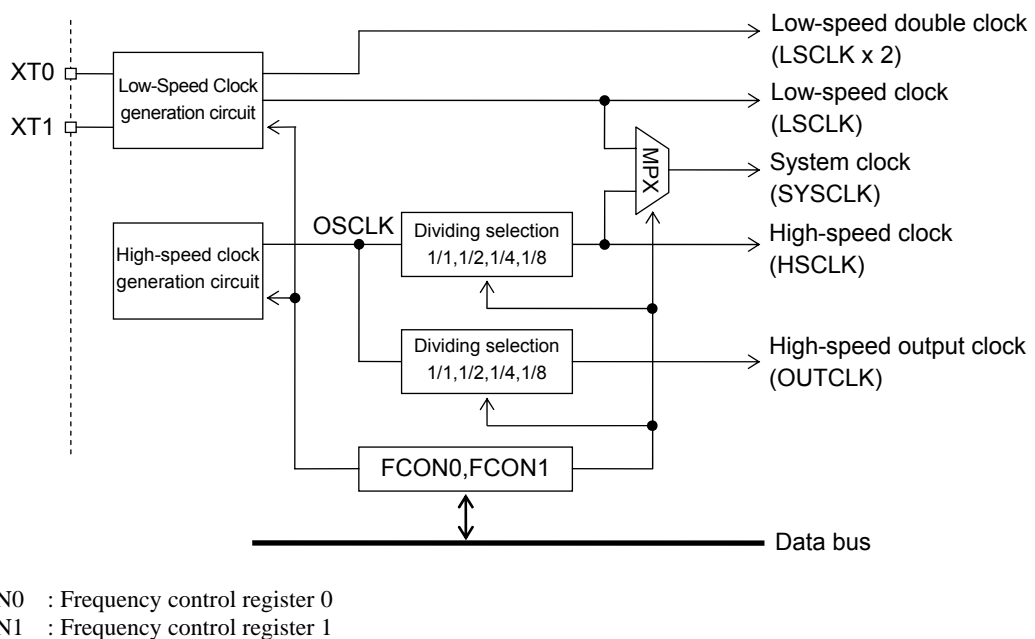

Figure 6-1 Configuration of Clock Generation Circuit

Note:

This LSI starts operation with the low-speed clock after power-on or a system reset. At initialization by software, set the FCON0 or FCON1 register to switch the clock to a required one. Operation of this LSI is not guaranteed under a condition where a low-speed clock is not supplied.

6.1.3 List of Pins

| Pin name | Input/output | Function |
|----------|--------------|---|
| XT0 | I | Pin for connecting a crystal for low-speed clock. |
| XT1 | O | Pin for connecting a crystal for low-speed clock. |

6.2 Description of Registers

6.2.1 List of Registers

| Address | Name | Symbol (Byte) | Symbol (Word) | R/W | Size | Initial value |
|---------|------------------------------|---------------|---------------|-----|------|---------------|
| 0F002H | Frequency control register 0 | FCON0 | FCON | R/W | 8/16 | 33H |
| 0F003H | Frequency control register 1 | FCON1 | | R/W | 8 | 00H |

6.2.2 Frequency Control Register 0 (FCON0)

Address: 0F002H
 Access: R/W
 Access size: 8/16 bit
 Initial value: 33H

| | | | | | | | | |
|---------------|-----|-------|-------|-------|-----|-----|-------|-------|
| | 7 | 6 | 5 | 4 | 3 | 2 | 1 | 0 |
| FCON0 | — | OSCM2 | OUTC1 | OUTC0 | — | — | SYSC1 | SYSC0 |
| R/W | R/W | R/W | R/W | R/W | R/W | R/W | R/W | R/W |
| Initial value | 0 | 0 | 1 | 1 | 0 | 0 | 1 | 1 |

FCON0 is a special function register (SFR) to control the high-speed clock generation circuit and to select system clock.

[Description of Bits]

- **SYSC1, SYSC0** (bits 1, 0)

The SYSC1 and SYSC0 bits are used to select the frequency of the high-speed clock (HSCLK) used for system clock and peripheral circuits (including high-speed time base counter). OSCLK, 1/2OSCLK, 1/4OSCLK, or 1/8OSCLK can be selected. The maximum operating frequency guaranteed for the system clock (SYSCLK) of this LSI is 500 kHz or 2 MHz.

At system reset, 1/8OSCLK is selected.

| SYSC1 | SYSC0 | Description |
|-------|-------|--------------------------|
| 0 | 0 | OSCLK |
| 0 | 1 | 1/2OSCLK |
| 1 | 0 | 1/4OSCLK |
| 1 | 1 | 1/8OSCLK (initial value) |

- **OUTC1, OUTC0** (bits 5, 4)

The OUTC1 and OUTC0 bits are used to select the frequency of the high-speed output clock which is output when the secondary function of the port is used. OSCLK, 1/2OSCLK, 1/4OSCLK, or 1/8OSCLK can be selected.

At system reset, 1/8OSCLK is selected.

| OUTC1 | OUTC0 | Description |
|-------|-------|--------------------------|
| 0 | 0 | OSCLK |
| 0 | 1 | 1/2OSCLK |
| 1 | 0 | 1/4OSCLK |
| 1 | 1 | 1/8OSCLK (initial value) |

- **OSCM2** (bit 6)

This bit sets the high-speed clock oscillation frequency. 500kHz or 2MHz can be selected. This bit can be written only when the high-speed clock oscillator circuit stops oscillating (During FCON1 register's ENOSC bit is "0").

| OSCM2 | Description |
|-------|------------------------------------|
| 0 | 500kHz oscillation (initial value) |
| 1 | 2MHz oscillation |

Note:

Internal logic voltage (V_{DDL}) is changed by OSCM2 bit. V_{DDL} becomes Typ.1.2V when OSCM2 is set to "0" and 500kHz oscillation is selected. V_{DDL} becomes Typ.1.5V when OSCM2 is set to "1" and 2MHz oscillation is selected. Ensure to write this bit when the high-speed clock oscillator circuit stops oscillating (During FCON1 register's ENOSC bit is "0").

6.2.3 Frequency Control Register 1 (FCON1)

Address: 0F003H
 Access: R/W
 Access size: 8-bit
 Initial value: 00H

| | | | | | | | | |
|---------------|-----|-----|-----|-----|-----|-------|-------|--------|
| | 7 | 6 | 5 | 4 | 3 | 2 | 1 | 0 |
| FCON1 | — | — | — | — | — | ENMLT | ENOSC | SYSCLK |
| R/W | R/W | R/W | R/W | R/W | R/W | R/W | R/W | R/W |
| Initial value | 0 | 0 | 0 | 0 | 0 | 0 | 0 | 0 |

FCON1 is a special function register (SFR) to control the high-speed clock generation circuit and to select system clock.

[Description of Bits]

- **SYSCLK** (bit 0)

The SYSCLK bit is used to select system clock. It allows selection of the low-speed clock (LSCLK) or HSCLK (1/nOSCLK: n = 1, 2, 4, 8) selected by using the high-speed clock frequency select bit (SYSC1, 0) of FCON0. When the oscillation of high-speed clock is stopped (ENOSC bit = "0"), the SYSCLK bit is fixed to "0" and the low-speed clock (LSCLK) is selected for system clock.

| SYSCLK | Description |
|--------|-----------------------|
| 0 | LSCLK (initial value) |
| 1 | HSCLK |

- **ENOSC** (bit 1)

The ENOSC bit is used to select enable/disable of the oscillation of the high-speed clock oscillator circuit.

| ENOSC | Description |
|-------|--|
| 0 | Stops high-speed oscillation (initial value) |
| 1 | Enables high-speed oscillation |

- **ENMLT** (bit 2)

The ENMLT bit is used to select enable/disable of the operation of the low-speed double clock (LSCLK x 2).

| ENMLT | Description |
|-------|---|
| 0 | Disables low-speed double clock operation (initial value) |
| 1 | Enables low-speed double clock operation |

6.3 Description of Operation

6.3.1 Low-Speed Clock

6.3.1.1 Low-Speed Clock Generation Circuit

Figure 6-2 shows the circuit configuration of the low-speed clock generation circuit.

For the low-speed clock generation circuit, externally provide a 32.768kHz crystal oscillator and capacitors (C_{GL} and C_{DL}).

In the STOP mode, Low-speed clock and Low-speed double clock oscillation are stopped.

When the ENMLT bit of FCON1 is set to "1", the low-speed double clock (LSCLK x 2) starts operation.

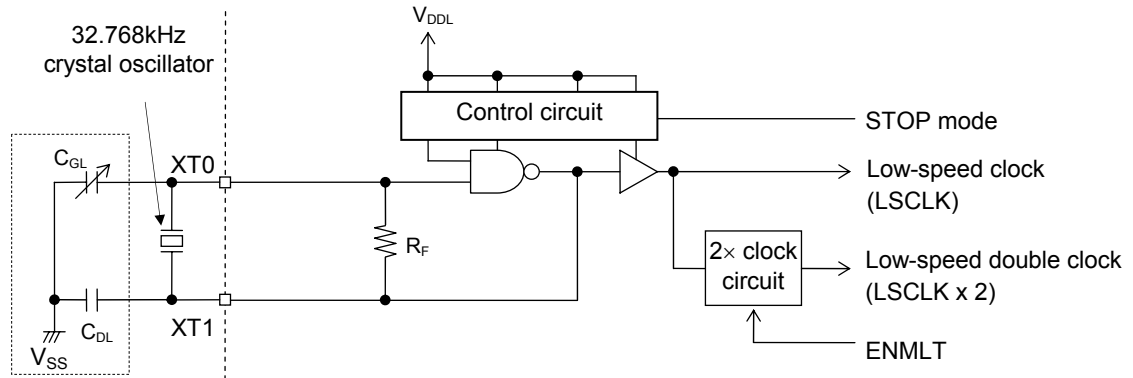

Figure 6-2 Circuit Configuration of 32.768 kHz Crystal Oscillation Mode

Note:

Install a crystal as close to the LSI as possible and make sure that signals causing noise and power supply wiring are not near the crystal and its wiring.

Note that oscillation may stop due to condensation.

6.3.1.2 Operation of Low-Speed Clock Generation Circuit

The low-speed clock generation circuit is activated by the occurrence of power ON reset.

After the power-on, it waits for the low-speed oscillation start time (T_{XTL}) and the low-speed clock (LSCLK) oscillation stabilization time (8192 counts). Then, the mode moves to the program run mode, the CPU starts operation, and at the same time the low-speed clock (LSCLK) is supplied to the peripheral circuits.

The low-speed clock generation circuit stops oscillation when it shifts to the STOP mode by software. When oscillation is resumed by releasing of the STOP mode by external interrupt, LSCLK is supplied to the peripheral circuits after the elapse of the low-speed oscillation start period (T_{XTL}) and low-speed clock (LSCLK) oscillation stabilization time (8192 counts). For STOP mode, see Chapter 4, "MCU Control Function".

Figure 6-3 shows the waveforms of the low-speed clock generation circuit. For the low-speed oscillation start time (T_{XTL}), see Appendix C, "Electrical Characteristics".

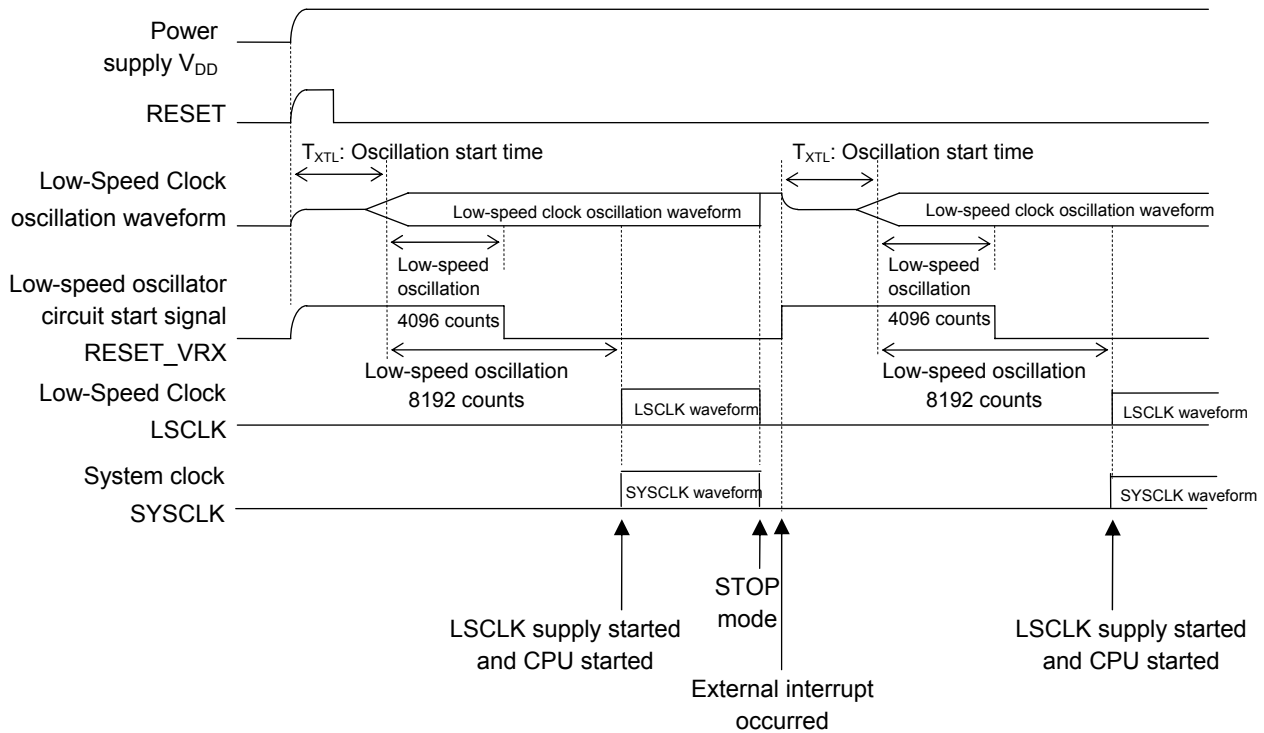

Figure 6-3 Operation of Low-Speed Clock Generation Circuit

Note:

After the power supply is turned on, CPU starts operation with the low-speed clock. After the STOP mode is released, the CPU starts operation with the low-speed clock (SYSCLK bit = "0") or high-speed clock (SYSCLK bit = "1") depending on the FCON1's SYSCLK bit.

6.3.2 High-speed clock

The high-speed clock is supplied from the RC oscillator circuit.

6.3.2.1 High-Speed Clock Circuit

After the oscillation is enabled (ENOSC set to "1"), the high-speed clock (OSCLK) supply starts in 16 counts of the RC oscillation clock.

Figure 6-4 shows the high-speed clock circuit configuration.

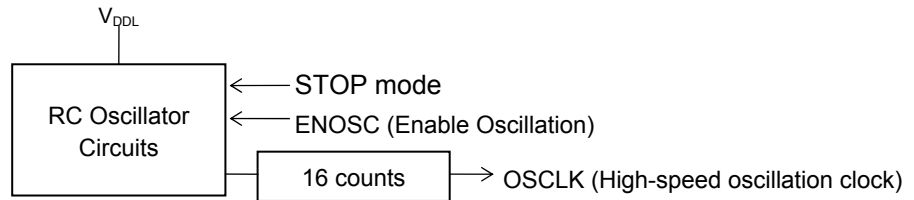

Figure 6-4 High-Speed Clock Circuit Configuration

Note:

- After the system reset mode is cleared, the OSCLK becomes the oscillation stopped state because the initial ENOSC value is "0". In the oscillation enabled (ENOSC set to "1") state, the OSCLK supply starts in 16 counts after the stop mode is released.

6.3.2.2 Operation of High-Speed Clock Generation Circuit

The high-speed clock generation circuit allows the start/stop control of oscillation by using the frequency control registers 0 and 1 (FCON0 and FCON1).

Oscillation can be started by setting the ENOSC bit of FCON1 to "1" after selecting a high-speed oscillation frequency with FCON0. After the start of oscillation, HSCLK starts supply of a clock to the peripheral circuits following the elapse of the high-speed oscillation start period (T_{RC}) and the oscillation stabilization time of the high-speed oscillation clock (OSCLK).

The high-speed clock generation circuit stops oscillation when it shifts to the STOP mode by software. When the STOP mode is released by external interrupt, HSCLK supplies clocks to peripheral circuits following the elapse of the high-speed oscillation start period (T_{RC}) and the oscillation stabilization time of the high-speed clock (OSCLK). The oscillation stabilization time is for 16 clocks.

Figure 6-5 shows the waveforms of the high-speed clock generation circuit.

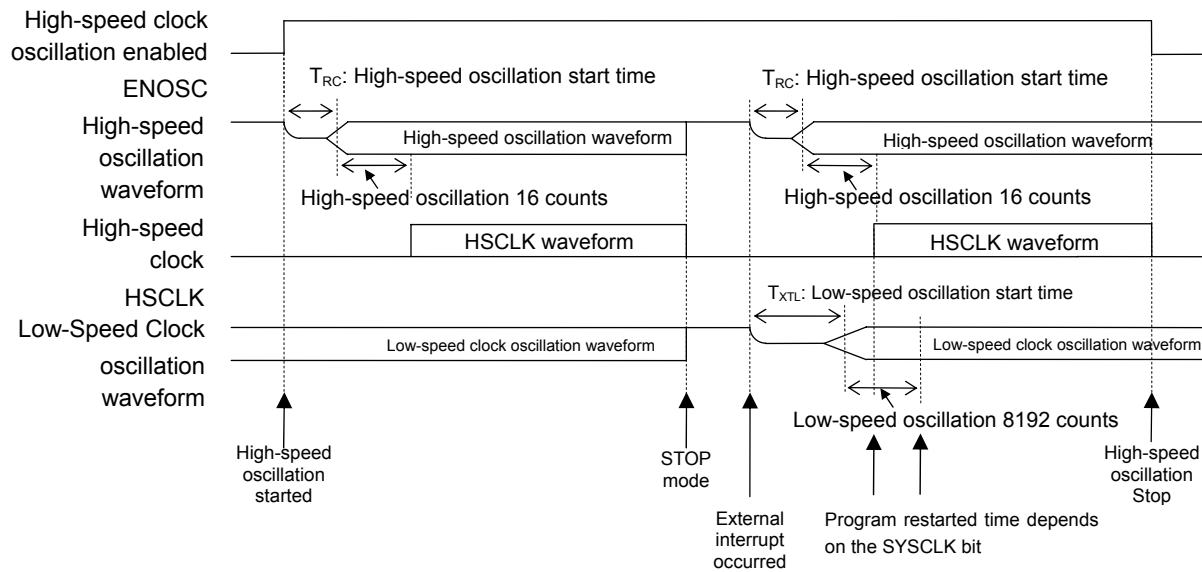

Figure 6-5 Operation of High-Speed Clock Generation Circuit

6.3.3 Switching of System Clock

The system clock can be switched between high-speed clock (HSCLK) and low-speed clock (LSCLK) by using the frequency control registers (FCON0, FCON1).

Figure 6-6 shows the flow chart of system clock switching processing (HSCLK to LSCLK) and Figure 6-7 shows the flow chart of system clock switching processing (LSCLK to HSCLK).

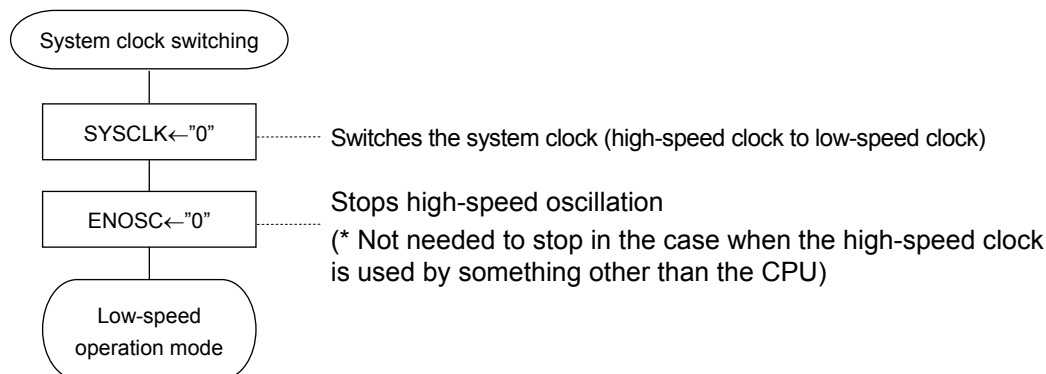

Figure 6-6 Flow of System Clock Switching Processing (HSCLK to LSCLK)

Note:

Immediately after the recovery from the STOP mode, if the system clock is switched from HSCLK to LSCLK, the CPU becomes inactive until LSCLK starts clock supply to the peripheral circuits. Therefore, It is recommended to switch to LSCLK after confirming that the LSCLK is oscillating by checking that the time base counter interrupt request bit (Q128H) is "1".

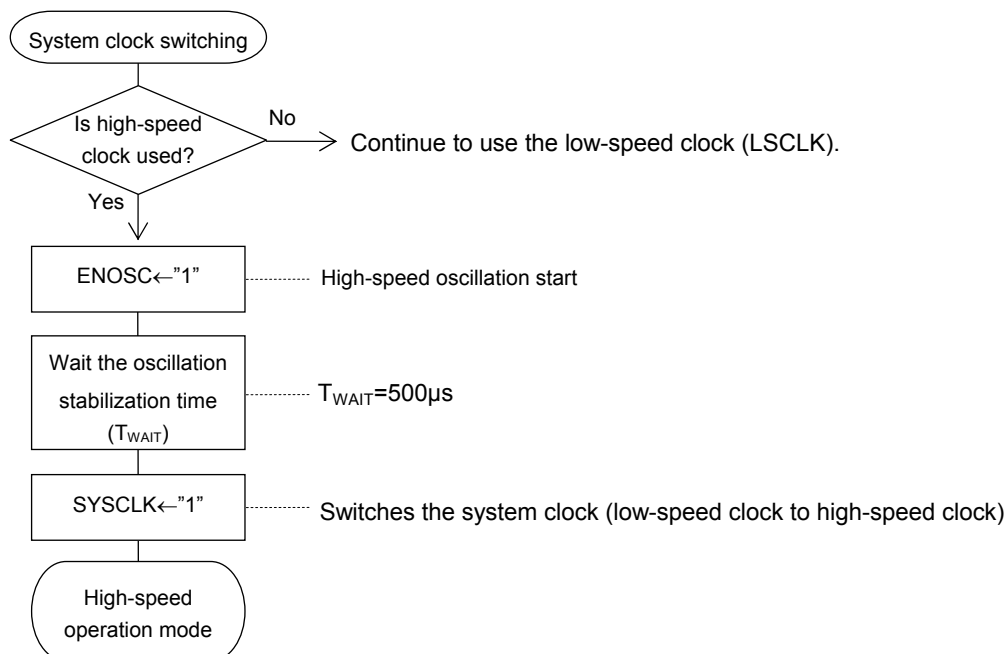

Figure 6-7 Flow of System Clock Switching Processing (LSCLK to HSCLK)

Note:

If the system clock is switched from a low-speed clock to a high-speed clock before the high-speed clock (HSCLK) starts oscillation, the CPU becomes inactive until HSCLK starts clock supply to the peripheral circuits.

6.4 Specifying Port Registers

To enable the clock output function, each related port register bit needs to be set. See Chapter 15, "Port 2" for detail about the port registers.

6.4.1 Functioning P21 (OUTCLK) as the high-speed clock output

Set P21MD bit (bit1 of P2MOD register) to "1" for specifying the high-speed clock output as the secondary function of P21.

| Register name | P2MOD register (Address: 0F214H) | | | | | | | |
|---------------|----------------------------------|---|---|---|---|-------|--------------|-------|
| Bit | 7 | 6 | 5 | 4 | 3 | 2 | 1 | 0 |
| Bit name | - | - | - | - | - | P22MD | P21MD | P20MD |
| Setting value | - | - | - | - | - | * | 1 | * |

Set the P21C1 bit (P2CON1 register's bit 1) to "1" and the P21C0 bit (P2CON0 register's bit 1) to "1" for specifying the state mode of the P21 pin to CMOS output.

| Register name | P2CON1 register (Address: 0F213H) | | | | | | | |
|---------------|-----------------------------------|---|---|---|---|-------|--------------|-------|
| Bit | 7 | 6 | 5 | 4 | 3 | 2 | 1 | 0 |
| Bit name | - | - | - | - | - | P22C1 | P21C1 | P20C1 |
| Setting value | - | - | - | - | - | * | 1 | * |

| Register name | P2CON0 register (Address: 0F212H) | | | | | | | |
|---------------|-----------------------------------|---|---|---|---|-------|--------------|-------|
| Bit | 7 | 6 | 5 | 4 | 3 | 2 | 1 | 0 |
| Bit name | - | - | - | - | - | P22C0 | P21C0 | P20C0 |
| Setting value | - | - | - | - | - | * | 1 | * |

The P21D bit (P2D register bit 1) data can either be "0" or "1".

| Register name | P2D register (Address: 0F210H) | | | | | | | |
|---------------|--------------------------------|---|---|---|---|------|-------------|------|
| Bit | 7 | 6 | 5 | 4 | 3 | 2 | 1 | 0 |
| Bit name | - | - | - | - | - | P22D | P21D | P20D |
| Setting value | - | - | - | - | - | * | ** | * |

- : Bit that does not exist

* : Bit not related to the high-speed clock function

** : Don't care

Note:

P21 (Port 2) is an output-only port and does not have the register to select the data direction(input or output).

6.4.2 Functioning P20 (LSCLK) as the low-speed clock output

Set P20MD bit (bit0 of P2MOD register) to "1" for specifying the low-speed clock output as the secondary function of P22.

| Register name | P2MOD register (Address: 0F214H) | | | | | | | |
|---------------|----------------------------------|---|---|---|---|-------|-------|--------------|
| Bit | 7 | 6 | 5 | 4 | 3 | 2 | 1 | 0 |
| Bit name | - | - | - | - | - | P22MD | P21MD | P20MD |
| Setting value | - | - | - | - | - | * | * | 1 |

Set the P20C1 bit (P2CON1 register bit 0) to "1" and the P20C0 bit (P2CON0 register bit 0) to "1" for selecting the P20 pin state mode to CMOS output.

| Register name | P2CON1 register (Address: 0F213H) | | | | | | | |
|---------------|-----------------------------------|---|---|---|---|-------|-------|--------------|
| Bit | 7 | 6 | 5 | 4 | 3 | 2 | 1 | 0 |
| Bit name | - | - | - | - | - | P22C1 | P21C1 | P20C1 |
| Setting value | - | - | - | - | - | * | * | 1 |

| Register name | P2CON0 register (Address: 0F212H) | | | | | | | |
|---------------|-----------------------------------|---|---|---|---|-------|-------|--------------|
| Bit | 7 | 6 | 5 | 4 | 3 | 2 | 1 | 0 |
| Bit name | - | - | - | - | - | P22C0 | P21C0 | P20C0 |
| Setting value | - | - | - | - | - | * | * | 1 |

Data of P20D bit (P2D register bit 0) does not affect to the low speed clock output function, so don't care the data for the function.

| Register name | P2D register (Address: 0F210H) | | | | | | | |
|---------------|--------------------------------|---|---|---|---|------|------|-------------|
| Bit | 7 | 6 | 5 | 4 | 3 | 2 | 1 | 0 |
| Bit name | - | - | - | - | - | P22D | P21D | P20D |
| Setting value | - | - | - | - | - | * | * | ** |

- : Bit that does not exist
- * : Bit not related to the low-speed clock function
- ** : Don't care

Note:
 P20 (Port 2) is an output-only port and does not have the register to select the data direction(input or output).

Time Base Counter

7. Time Base Counter

7.1 Overview

This LSI includes a low-speed time base counter (LTBC) and a high-speed time base counter (HTBC) that generate base clocks for peripheral circuits. By using the time base counter, it is possible to generate events periodically. For input clocks, see Chapter 6, "Clock Generation Circuit". For interrupt permission, interrupt request flags, etc., described in this chapter, see Chapter 5, "Interrupt".

7.1.1 Features

- LTBC generates T32KHZ to T1HZ signals by dividing the low-speed clock (LSCLK) frequency.
- LTBC allows frequency adjustment (Adjustment range: Approx. -488ppm to +488ppm. Adjustment accuracy: Approx. 0.48ppm) by using the low-speed time base counter frequency adjustment registers (LTBADJH and LTBADJL).
- HTBC generates HTB1 to HTB32 signals by dividing the high-speed clock (HSCLK) frequency.
- Capable of generating 128Hz , 32Hz , 16Hz , and 2Hz interrupts.

7.1.2 Configuration

Figure 7-1 and Figure 7-2 show the configuration of a low-speed time base counter and a high-speed time base counter, respectively.

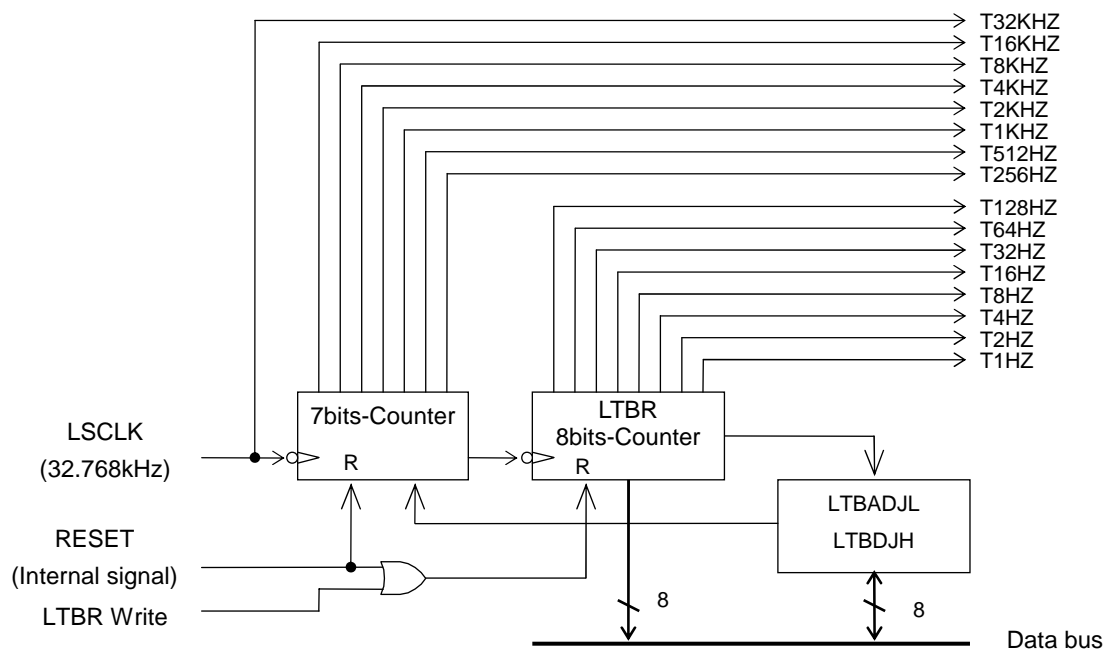

LTBR : Low-speed time base counter register
 LTBADJL : Low-speed time base counter frequency adjustment register
 LTBADJH : Low-speed time base counter frequency adjustment register

Figure 7-1 Configuration of Low-Speed Time Base Counter (LTBC)

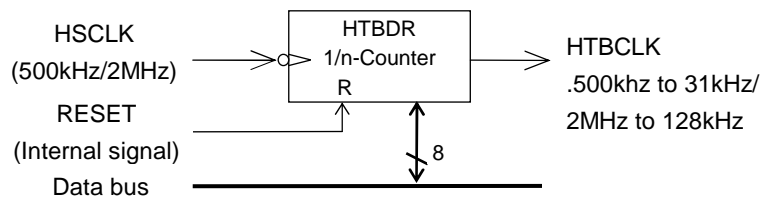

HTBDR : High-speed time base counter frequency divide register

Figure 7-2 Configuration of High-Speed Time Base Counter

Note:

The frequency of HSCLK changes according to specified data in OSCM2, SYSC1, and SYSC0 bits of Frequency control register 0 (FON0).

7.2 Description of Registers

7.2.1 List of Registers

| Address | Name | Symbol (Byte) | Symbol (Word) | R/W | Size | Initial value |
|---------|---|---------------|---------------|-----|------|---------------|
| 0F00AH | Low-speed time base counter register | LTBR | — | R/W | 8 | 00H |
| 0F00BH | High-speed time base counter frequency divide register | HTBDR | — | R/W | 8 | 00H |
| 0F00CH | Low-speed time base counter frequency adjustment register L | LTBADJL | LTBADJ | R/W | 8/16 | 00H |
| 0F00DH | Low-speed time base counter frequency adjustment register H | LTBADJH | | R/W | 8 | 00H |

7.2.2 Low-Speed Time Base Counter Register (LTBR)

Address: 0F00AH

Access: R/W

Access size: 8-bit

Initial value: 00H

| | 7 | 6 | 5 | 4 | 3 | 2 | 1 | 0 |
|---------------|------|------|------|------|-------|-------|-------|--------|
| LTBR | T1HZ | T2HZ | T4HZ | T8HZ | T16HZ | T32HZ | T64HZ | T128HZ |
| R/W | R/W | R/W | R/W | R/W | R/W | R/W | R/W | R/W |
| Initial value | 0 | 0 | 0 | 0 | 0 | 0 | 0 | 0 |

LTBR is a special function register (SFR) to read the T128HZ to T1HZ outputs of the low-speed time base counter. The T128HZ-T1HZ outputs are set to "0" when write operation is performed for LTBR. Write data is invalid.

Note:

A TBC interrupt (128Hz interrupt, 32Hz interrupt, 16Hz interrupt, or 2Hz interrupt) may occur depending on the LTBR write timing. Take this into consideration when programming your software by referring to "Figure 7-4 Interrupt Timing and Reset Timing by Writing to LTBR."

7.2.3 High-Speed Time Base Counter Divide Register (HTBDR)

Address: 0F00BH
Access: R/W
Access size: 8-bit
Initial value: 00H

| | | | | | | | | |
|---------------|-----|-----|-----|-----|------|------|------|------|
| | 7 | 6 | 5 | 4 | 3 | 2 | 1 | 0 |
| HTBDR | — | — | — | — | HTD3 | HTD2 | HTD1 | HTD0 |
| R/W | R/W | R/W | R/W | R/W | R/W | R/W | R/W | R/W |
| Initial value | 0 | 0 | 0 | 0 | 0 | 0 | 0 | 0 |

HTBDR is a special function register (SFR) to set the dividing ratio of the 4-bit, 1/n counter.

[Description of Bits]

- **HTD3-HTD0** (bits 3-0)

The HTD3-HTD0 bits are used to set the dividing ratio of the 4-bit, 1/n counter. The frequency divide ratios selectable include 1/1 to 1/16.

| HTD3 | HTD2 | HTD1 | HTD0 | Description | |
|------|------|------|------|----------------------|--------------------------|
| | | | | Dividing ratio | Frequency of HTBCLK (*1) |
| 0 | 0 | 0 | 0 | 1/16 (initial value) | 31kHz |
| 0 | 0 | 0 | 1 | 1/15 | 33kHz |
| 0 | 0 | 1 | 0 | 1/14 | 36kHz |
| 0 | 0 | 1 | 1 | 1/13 | 38kHz |
| 0 | 1 | 0 | 0 | 1/12 | 42kHz |
| 0 | 1 | 0 | 1 | 1/11 | 45kHz |
| 0 | 1 | 1 | 0 | 1/10 | 50kHz |
| 0 | 1 | 1 | 1 | 1/9 | 56kHz |
| 1 | 0 | 0 | 0 | 1/8 | 63kHz |
| 1 | 0 | 0 | 1 | 1/7 | 71kHz |
| 1 | 0 | 1 | 0 | 1/6 | 83kHz |
| 1 | 0 | 1 | 1 | 1/5 | 100kHz |
| 1 | 1 | 0 | 0 | 1/4 | 125kHz |
| 1 | 1 | 0 | 1 | 1/3 | 167kHz |
| 1 | 1 | 1 | 0 | 1/2 | 250kHz |
| 1 | 1 | 1 | 1 | 1/1 | 500kHz |

*1: Indicates the frequency when the high-speed oscillation clock, HSCLK, is 500 kHz.

7.2.4 Low-Speed Time Base Counter Frequency Adjustment Registers L and H (LTBADJL, LTBADJH)

Address: 0F00CH
 Access: R/W
 Access size: 8/16 bit
 Initial value: 00H

| | | | | | | | | |
|---------------|-------|-------|-------|-------|-------|-------|-------|-------|
| | 7 | 6 | 5 | 4 | 3 | 2 | 1 | 0 |
| LTBADJL | LADJ7 | LADJ6 | LADJ5 | LADJ4 | LADJ3 | LADJ2 | LADJ1 | LADJ0 |
| R/W | R/W | R/W | R/W | R/W | R/W | R/W | R/W | R/W |
| Initial value | 0 | 0 | 0 | 0 | 0 | 0 | 0 | 0 |

Address: 0F00DH
 Access: R/W
 Access size: 8-bit
 Initial value: 00H

| | | | | | | | | |
|---------------|-----|-----|-----|-----|-----|-------|-------|-------|
| | 7 | 6 | 5 | 4 | 3 | 2 | 1 | 0 |
| LTBADJH | — | — | — | — | — | LADJS | LADJ9 | LADJ8 |
| R/W | R/W | R/W | R/W | R/W | R/W | R/W | R/W | R/W |
| Initial value | 0 | 0 | 0 | 0 | 0 | 0 | 0 | 0 |

LTBADJL and LTBADJH are special function registers (SFRs) to set the frequency adjustment values of the low-speed time base clock.

[Description of Bits]

- LADJS, LADJ9 to LADJ8** (bits 2 to 0) **LADJ7-LADJ0** (bits 7 to 0)
 The LADJS and LADJ9 to LADJ0 bits are used to adjust frequency.
 Adjustment range: approximately -488ppm to +488ppm, Adjustment accuracy: approximately 0.48ppm is possible. See Section 7.3.3, “Low-Speed Time Base Counter Frequency Adjustment Function” for the correspondence between the frequency adjustment values (LTBADJH, LTBADJL) and adjustment ratio.

7.3 Description of Operation

7.3.1 Low-speed Time Base Counter

The low-speed time base counter (LTBC) starts counting from 0000H on the LSCLK falling edge after system reset. The T128HZ, T32HZ, T16HZ, and T2HZ outputs of LTBC are used as time base interrupts and an interrupt is requested on the falling edge of each output. Each of LTBC outputs is also used as an operation clock for peripheral circuits. The output data of T128HZ to T1HZ of LTBC can be read from the low-speed time base counter register (LTBR). When reading the data, read LTBR twice and check that the two values coincide to prevent reading of undefined data during counting.

Figure 7-3 shows an example of program to read LTBR.

```

        LEA    offset LTBR      ; EA LTBR address
MARK:   L      R0,    [EA]       ; 1st read
        L      R1,    [EA]       ; 2nd read
;
        CMP    R0,    R1        ; Comparison for LTBR
        BNE   MARK          ; To MARK when the values do not coincide
;
        :

```

Figure 7-3 Programming Example for Reading LTBR

LTBR is reset when write operation is performed and the T128HZ to T1HZ outputs are set to “0”. Write data is invalid. Since an interrupt occurs if a falling edge occurs in the T128HZ to T2HZ outputs during writing to LTBR, take care in software programming.

Figure 7-4 shows interrupt generation timing and reset timing of the time base counter output by writing to LTBR.

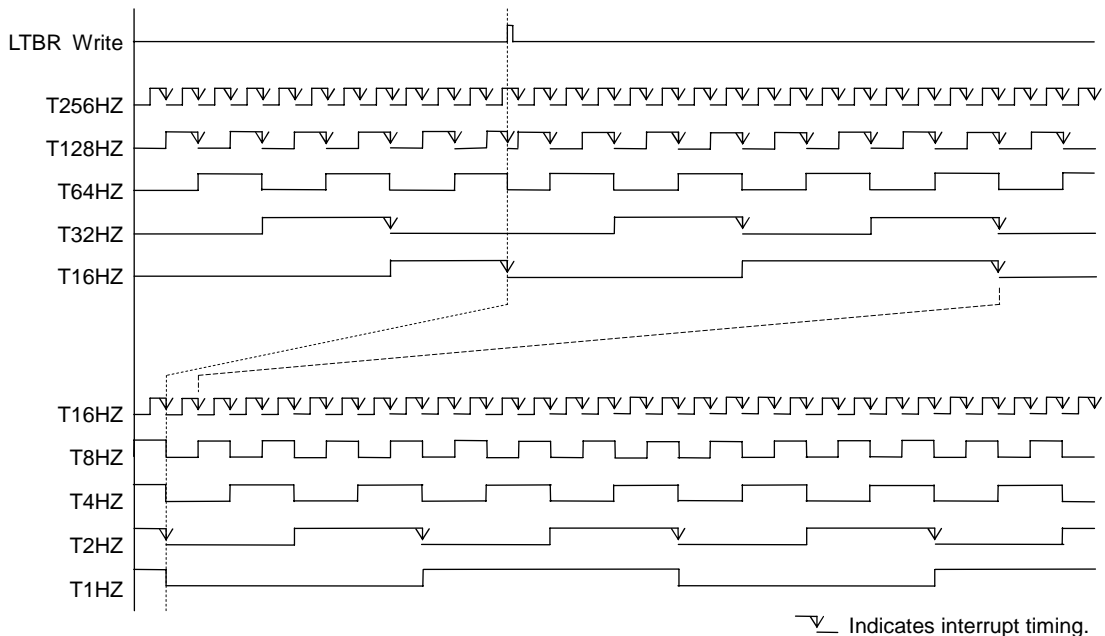

Figure 7-4 Interrupt Timing and Reset Timing by Writing to LTBR

7.3.2 High-Speed Time Base Counter

The high-speed time base counter is configured as a 4-bit 1/n counter (n = 1 to 16).

In the 4-bit 1/n counter, the divided clock ($1/16 \times \text{HSCLK}$ to $1/1 \times \text{HSCLK}$) selected by the high-speed time base counter divide register (HTBDR) is generated as HTBCLK. HTBCLK is used as a timer and also as an operation clock of PWM.

Figure 7-5 shows the output waveform of HTBCLK.

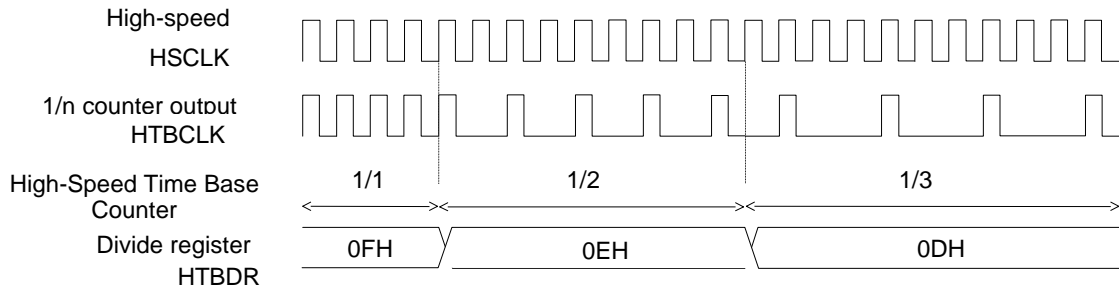

Figure 7-5 Output Waveform of HTBCLK

7.3.3 Low-Speed Time Base Counter Frequency Adjustment Function

Frequency adjustment (Adjustment range: Approx. -488ppm to +488ppm. Adjustment accuracy: Approx. 0.48ppm) is possible for outputs of T8KHZ to T1HZ of LTBC by using the low-speed time base counter frequency adjust registers (LTBADJH and LTBADJL).

Table7-1 shows correspondence between the frequency adjustment values (LTBADJH, LTBADJL) and adjustment ratio.

Table 7-1 Correspondence between Frequency Adjustment Values (LTBADJH, LTBADJL) and Adjustment Ratio

| LADJ10-0 | | | | | | | | | | | Hexadecimal | Frequency adjustment ratio (ppm) |
|----------|---|---|---|---|---|---|---|---|---|---|-------------|----------------------------------|
| 0 | 1 | 1 | 1 | 1 | 1 | 1 | 1 | 1 | 1 | 1 | 3FFH | +487.80 |
| 0 | 1 | 1 | 1 | 1 | 1 | 1 | 1 | 1 | 1 | 0 | 3FEH | +487.33 |
| ; | ; | ; | ; | ; | ; | ; | ; | ; | ; | ; | | ; |
| 0 | 0 | 0 | 0 | 0 | 0 | 0 | 0 | 0 | 1 | 1 | 003H | +1.43 |
| 0 | 0 | 0 | 0 | 0 | 0 | 0 | 0 | 0 | 1 | 0 | 002H | +0.95 |
| 0 | 0 | 0 | 0 | 0 | 0 | 0 | 0 | 0 | 0 | 1 | 001H | +0.48 |
| 0 | 0 | 0 | 0 | 0 | 0 | 0 | 0 | 0 | 0 | 0 | 000H | 0 |
| 1 | 1 | 1 | 1 | 1 | 1 | 1 | 1 | 1 | 1 | 1 | 7FFH | -0.48 |
| 1 | 1 | 1 | 1 | 1 | 1 | 1 | 1 | 1 | 1 | 0 | 7FEH | -0.95 |
| ; | ; | ; | ; | ; | ; | ; | ; | ; | ; | ; | | ; |
| 1 | 0 | 0 | 0 | 0 | 0 | 0 | 0 | 0 | 0 | 1 | 401H | -487.80 |
| 1 | 0 | 0 | 0 | 0 | 0 | 0 | 0 | 0 | 0 | 0 | 400H | -488.28 |

The adjustment values (LADJ10 to LADJ0) to be set in LTBADJH and LTBADJL can be obtained by using the following equations:

$$\begin{aligned} \text{Adjustment value} &= \text{Frequency adjustment ratio} \times 2097152 \text{ (decimal)} \\ &= \text{Frequency adjustment ratio} \times 200000h \text{ (hexadecimal)} \end{aligned}$$

Example 1: When adjusting +15.0ppm (when the clock loses)

$$\begin{aligned} \text{Adjustment value} &= +15.0\text{ppm} \times 2097152 \text{ (decimal)} \\ &= +15.0 \times 10^{-6} \times 2097152 \\ &= +31.45728 \text{ (decimal)} \\ &\cong 01Fh \text{ (hexadecimal)} \end{aligned}$$

Example 2: When adjusting -25.5ppm (when the clock gains)

$$\begin{aligned} \text{Adjustment value} &= -25.5\text{ppm} \times 2097152 \text{ (decimal)} \\ &= -25.5 \times 10^{-6} \times 2097152 \\ &= -53.477376 \text{ (decimal)} \\ &\cong 7CCh \text{ (hexadecimal)} \end{aligned}$$

Note:

The low-speed clock (LSCLK) and the outputs of T32KHZ and T16KHZ of LTBC are not adjusted by the frequency adjust function.

The frequency adjustment accuracy does not guarantee the accuracy including the frequency variation of the crystal oscillation (32.768kHz) due to temperature variations.

7.3.4 A signal generation for 16-bit timer 2-3 frequency measurement mode

A signal (437C) used for 16-bit timer 0-1 frequency measurement mode is generated from the output clock of the low-speed time base counter. See Chapter 9, "Timer" for more detail about the frequency measurement mode.

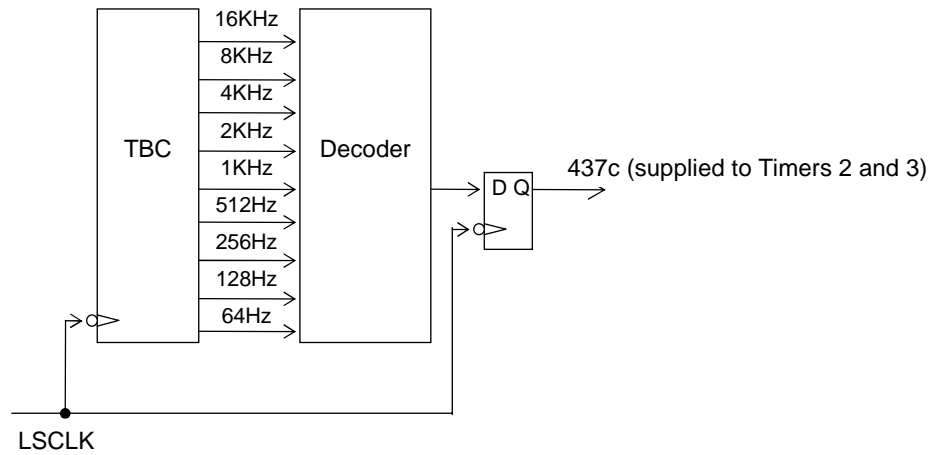

Figure 7-6 Configuration of Frequency Measurement Mode Clock (437c) Generation Circuit

Chapter 8

Capture

8. Capture

8.1 Overview

This LSI has two channels of capture circuits that capture the T4KHZ to T32HZ signals of the low-speed time base counter (LTBC) to the capture data register at the occurrence of P00 and P01 interrupts. The circuits capture timings at which each interrupt occurred, based on the time from the time base counter. It can also read out the T4KHZ to T32HZ signals of the low-speed time base counter (LTBC) at any timing.

For the external interrupt (P00INT, P01INT) from the P00 or P01 pin, see Chapter 5, "Interrupt" and Chapter 14, "Port 0".

8.1.1 Features

- Time base capture x 2 channels (4096Hz to 32Hz)

8.1.2 Configuration

Figure 8-1 shows the configuration of the capture circuit.

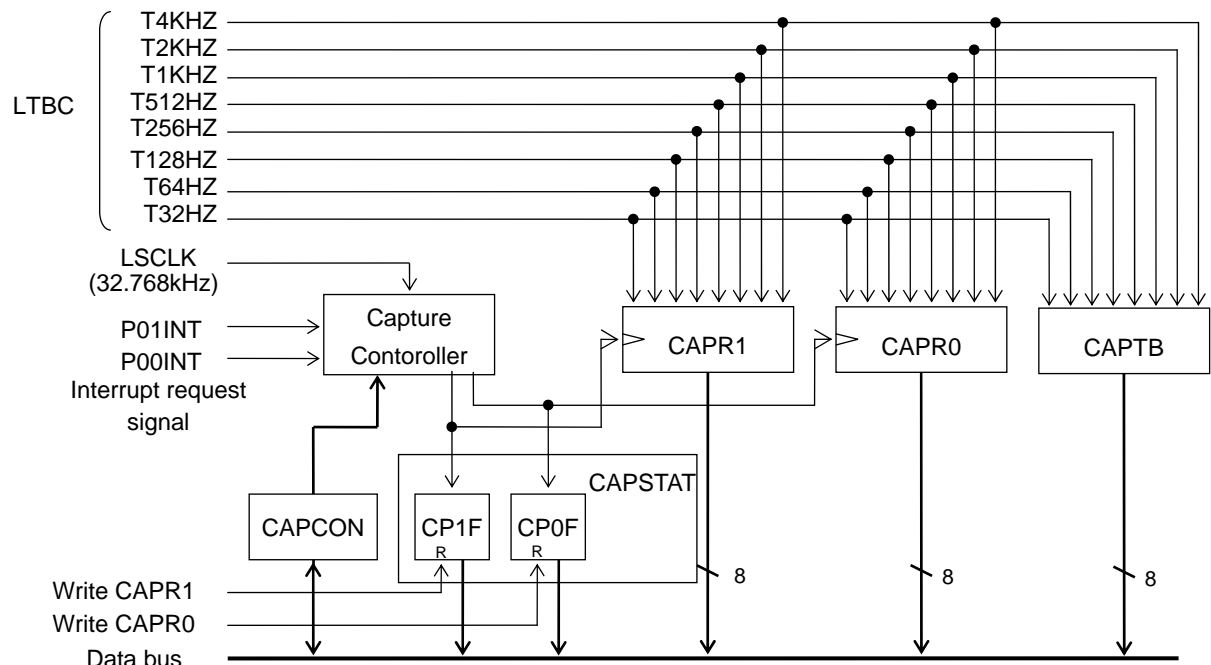

CAPCON : Capture control register
CAPSTAT : Capture status register
CAPR0 : Capture data register 0
CAPR1 : Capture data register 1
CAPTB : Capture time base data register

Figure 8-1 Configuration of Capture Circuit

8.1.3 List of Pins

| Pin name | I/O | Function |
|----------|-----|---|
| P00/CAP0 | I | Capture 0 input pin Used as the secondary function of the P00 pin. |
| P01/CAP1 | I | Capture 1 input pin Used as the secondary function of the P01 pin. |

8.2 Description of Registers

8.2.1 List of Registers

| Address | Name | Symbol (Byte) | Symbol (Word) | R/W | Size | Initial value |
|---------|---------------------------------|---------------|---------------|-----|------|---------------|
| 0F090H | Capture control register | CAPCON | — | R/W | 8 | 00H |
| 0F091H | Capture status register | CAPSTAT | — | R | 8 | 00H |
| 0F092H | Capture data register 0 | CAPR0 | — | R/W | 8 | 00H |
| 0F093H | Capture data register 1 | CAPR1 | — | R/W | 8 | 00H |
| 0F094H | Capture time base data register | CAPTB | — | R | 8 | Undefined |

8.2.2 Capture Control Register (CAPCON)

Address: 0F090H
 Access: R/W
 Access size: 8-bit
 Initial value: 00H

| | | | | | | | | |
|---------------|-----|-----|-----|-----|-----|-----|-------|-------|
| | 7 | 6 | 5 | 4 | 3 | 2 | 1 | 0 |
| CAPCON | — | — | — | — | — | — | ECAP1 | ECAP0 |
| R/W | R/W | R/W | R/W | R/W | R/W | R/W | R/W | R/W |
| Initial value | 0 | 0 | 0 | 0 | 0 | 0 | 0 | 0 |

CAPCON is a special function register (SFR) to control the capture circuit.

[Description of Bits]

- **ECAP0** (bit 0)
 The ECAP0 bit is used to start or stop the operation of capture 0.

| ECAP0 | Description |
|-------|--|
| 0 | Stops the capture 0 operation. (initial value) |
| 1 | Starts the capture 0 operation. |

- **ECAP1** (bit 1)
 The ECAP1 bit is used to start or stop the operation of capture 1.

| ECAP1 | Description |
|-------|--|
| 0 | Stops the capture 1 operation. (initial value) |
| 1 | Starts the capture 1 operation. |

8.2.3 Capture Status Register (CAPSTAT)

Address: 0F091H
 Access: R
 Access size: 8-bit
 Initial value: 00H

| | | | | | | | | |
|---------------|---|---|---|---|---|---|-------|-------|
| | 7 | 6 | 5 | 4 | 3 | 2 | 1 | 0 |
| CAPSTAT | — | — | — | — | — | — | CAPF1 | CAPF0 |
| R/W | R | R | R | R | R | R | R | R |
| Initial value | 0 | 0 | 0 | 0 | 0 | 0 | 0 | 0 |

CAPSTAT is a read-only, special function register (SFR) to indicate a state of the capture circuit.

[Description of Bits]

- **CAPF0** (bit 0)

The CAPF0 bit is the flag to indicate whether data is captured in capture data register 0 (CARP0) or not. When the CAPF0 bit is set to "1", it indicates that data is captured in capture data register 0 (CARP0).

When the CAPF0 bit is set to "1", the next capture operation is stopped. So perform the write operation to capture data register 0 (CAPR0) to clear the CAPF0 bit to "0".

| CAPF0 | Description |
|-------|------------------------------------|
| 0 | No capture 0 latch (initial value) |
| 1 | Capture 0 latch |

- **CAPF1** (bit 1)

The CAPF1 bit is the flag to indicate whether data is captured in capture data register 1 (CARP1) or not. When the CAPF1 bit is set to "1", it indicates that data is captured in capture data register 1 (CARP1).

When the CAPF1 bit is set to "1", the next capture operation is stopped. So perform the write operation to capture data register 1 (CAPR1) to clear the CAPF1 bit to "0".

| CAPF1 | Description |
|-------|------------------------------------|
| 0 | No capture 1 latch (initial value) |
| 1 | Capture 1 latch |

8.2.4 Capture Data Register 0 (CAPR0)

Address: 0F092H
 Access: R/W
 Access size: 8-bit
 Initial value: 00H

| | | | | | | | | |
|---------------|------|------|------|------|------|------|------|------|
| | 7 | 6 | 5 | 4 | 3 | 2 | 1 | 0 |
| CAPR0 | CP07 | CP06 | CP05 | CP04 | CP03 | CP02 | CP01 | CP00 |
| R/W | R/W | R/W | R/W | R/W | R/W | R/W | R/W | R/W |
| Initial value | 0 | 0 | 0 | 0 | 0 | 0 | 0 | 0 |

CAPR0 is a register in which capture data is stored.

The T4KHZ to T32HZ signals of the low-speed time base counter (LTBC) are captured when the P00 interrupt request is generated with the CAPF0 flag (bit 0 of the CAPSTAT register) set to "0".

Writing to CAPR0 sets the CAPF0 flag of CAPSTAT to "0". The value of CAPR0 does not change even if data is written to it.

8.2.5 Capture Data Register 1 (CAPR1)

Address: 0F093H
Access: R/W
Access size: 8-bit
Initial value: 00H

| | 7 | 6 | 5 | 4 | 3 | 2 | 1 | 0 |
|---------------|------|------|------|------|------|------|------|------|
| CAPR1 | CP17 | CP16 | CP15 | CP14 | CP13 | CP12 | CP11 | CP10 |
| R/W | R/W | R/W | R/W | R/W | R/W | R/W | R/W | R/W |
| Initial value | 0 | 0 | 0 | 0 | 0 | 0 | 0 | 0 |

CAPR1 is a register in which capture data is stored.

The T4KHZ to T32HZ signals of the low-speed time base counter (LTBC) are captured when the P01 interrupt request is generated with the CAPF1 flag (bit 1 of the CAPSTAT register) set to "0".

Writing to CAPR1 sets the CAPF1 flag of CAPSTAT to "0". The value of CAPR1 does not change even if data is written to it.

8.2.6 Capture Time Base Data Register (CAPTB)

Address: 0F094H
 Access: R
 Access size: 8-bit
 Initial value: Undefined

| | 7 | 6 | 5 | 4 | 3 | 2 | 1 | 0 |
|-------------------|--------------------|--------------------|--------------------|--------------------|--------------------|--------------------|--------------------|--------------------|
| CAPT _B | CPT _B 7 | CPT _B 6 | CPT _B 5 | CPT _B 4 | CPT _B 3 | CPT _B 2 | CPT _B 1 | CPT _B 0 |
| R | R | R | R | R | R | R | R | R |
| Initial value | X | X | X | X | X | X | X | X |

CAPT_B is a special function register (SFR) to read the T4KHZ to T32HZ outputs of the low-speed time base counter (LTBC). The initial value varies depending on the state of the T4KHZ to T32HZ outputs of the low-speed time base counter (LTBC) at the timing when this register is read. When reading the data, read this register twice and check that the two values coincide to prevent reading of undefined data during counting.

8.3 Description of Operation

The capture circuit starts the capture operation by setting the ECAP0 or ECAP1 bit of the capture control register (CAPCON).

When the input trigger from the P00 or P01 pin selected by the external interrupt control register 0 or 1 (EXICON0 or EXICON1) is generated and the P00 or P01 interrupt request flag (QP00 or QP01) is set to "1", the T4KHZ to T32HZ signals of the low-speed time base counter (LTBC) are captured in the capture data register 0 or 1 (CAPR0 or CAPR1) on the next low-speed clock (LSCLK) falling edge and the at the same time, the capture flag (CAPF0 or CAPF1) of the capture status register (CAPSTAT) is set to "1".

When the capture flag (CAPF0, CAPF1) is "1", the following capture operation stops.

The value, once captured by software into the capture data register 0 or 1 (CAPR0, CAPR1), is read to the CPU. Then, in preparation for the next capture operation, the writing operation is performed to the applicable capture data register 0 or 1 (CAPR0, CAPR1)(write data is meaningless), the capture flag (CAPF0, CAPF1) is cleared to "0", then the next P00 or P01 interrupt is waited.

Figure 8-2 shows the timing of the capture operation.

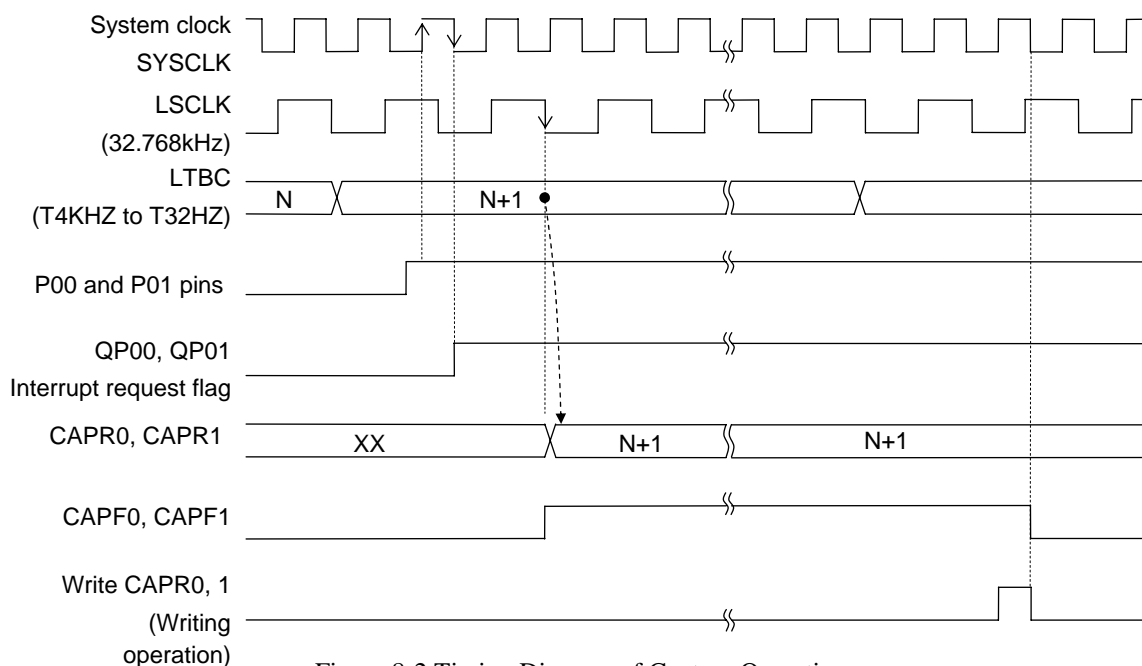

Figure 8-2 Timing Diagram of Capture Operation

Note:

When CPU is operating on the high-speed clock (HSCLK), check that the capture flag (CAPF0, CAPF1) is set to "1" after the P00 or P01 interrupt request is generated and then read capture data register 0 or 1 (CAPR0, CAPR1).

Chapter 9

Timer

9. Timer

9.1 Overview

This LSI includes 4 channels of 8-bit timers.

9.1.1 Features

- The timer interrupt (TMnINT) is generated when the values of timer counter register (TMnC, n=0 to 3) and timer data register (TMnD) coincide.
- A timer configured by combining timer 0 and timer 1 or timer 2 and timer 3 can be used as a 16-bit timer.
- For the timer clock, the low-speed clock (LSCLK), high-speed time base clock (HTBCLK), or external clock can be selected.
- A 16bit-timer 2 & 3 has clock frequency measurement mode, which can count HTBCLK and generates the timer interrupt (TM3INT) when the count ends.
Using the count data to know the frequency by software can determine more accurate baud-rate.

9.1.2 Configuration

Figure 9-1 shows the configuration of the timers.

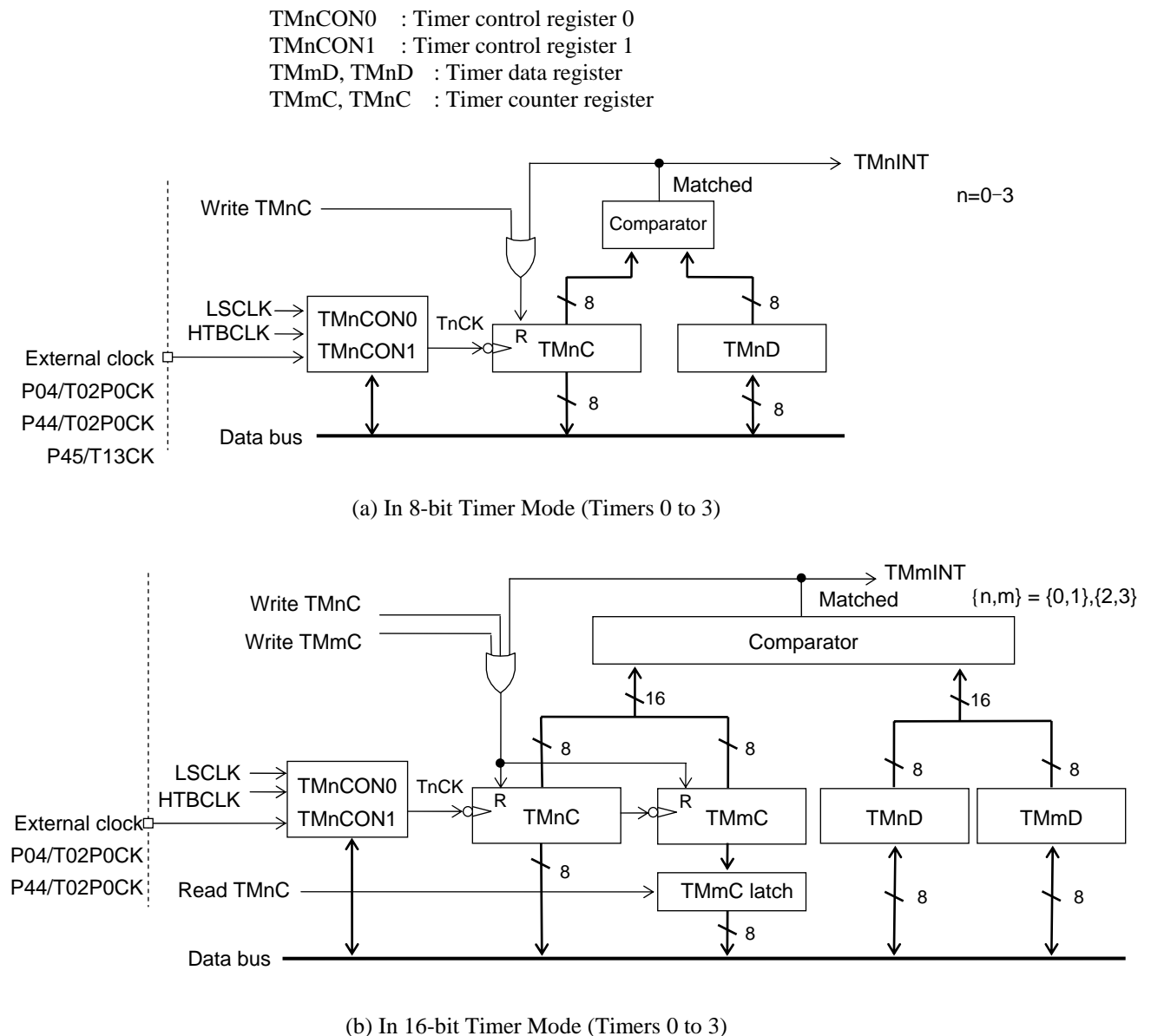

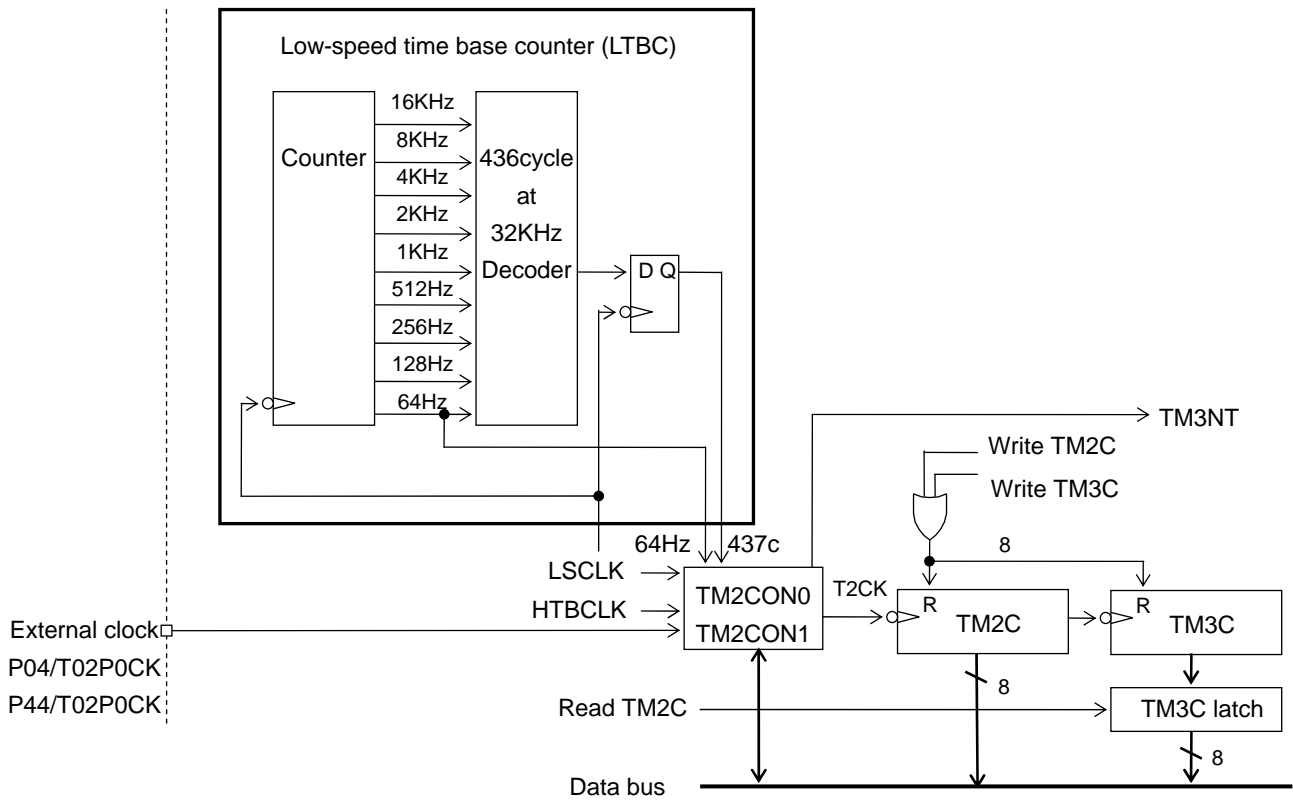

(c) Frequency measurement mode with 16 bit timer(Timer2 to 3)

Figure 9-1 Timer Configuration

9.1.3 List of Pins

| Pin name | I/O | Function |
|-------------|-----|--|
| P04/T02P0CK | I | External clock input pin 8bit timer mode : used for timer0 or timer2 16bit timer mode : used for timer0 to timer1 or timer2 to timer3. |
| P44/T02P0CK | I | External clock input pin 8bit timer mode : used for timer0 or timer2 16bit timer mode : used for timer0 to timer1 or timer2 to timer3. |
| P45/T13CK | I | External clock input pin 8bit timer mode : used for timer1 or timer3 |

9.2 Description of Registers

9.2.1 List of Registers

| Address | Name | Symbol (Byte) | Symbol (Word) | R/W | Size | Initial value |
|---------|----------------------------|---------------|---------------|-----|------|---------------|
| 0F030H | Timer 0 data register | TM0D | TM0DC | R/W | 8/16 | 0FFH |
| 0F031H | Timer 0 counter register | TM0C | | R/W | 8 | 00H |
| 0F032H | Timer 0 control register 0 | TM0CON0 | TM0CON | R/W | 8/16 | 00H |
| 0F033H | Timer 0 control register 1 | TM0CON1 | | R/W | 8 | 00H |
| 0F034H | Timer 1 data register | TM1D | TM1DC | R/W | 8/16 | 0FFH |
| 0F035H | Timer 1 counter register | TM1C | | R/W | 8 | 00H |
| 0F036H | Timer 1 control register 0 | TM1CON0 | TM1CON | R/W | 8/16 | 00H |
| 0F037H | Timer 1 control register 1 | TM1CON1 | | R/W | 8 | 00H |
| 0F038H | Timer 2 data register | TM2D | TM2DC | R/W | 8/16 | 0FFH |
| 0F039H | Timer 2 counter register | TM2C | | R/W | 8 | 00H |
| 0F03AH | Timer 2 control register 0 | TM2CON0 | TM2CON | R/W | 8/16 | 0A0H |
| 0F03BH | Timer 2 control register 1 | TM2CON1 | | R/W | 8 | 00H |
| 0F03CH | Timer 3 data register | TM3D | TM3DC | R/W | 8/16 | 0FFH |
| 0F03DH | Timer 3 counter register | TM3C | | R/W | 8 | 00H |
| 0F03EH | Timer 3 control register 0 | TM3CON0 | TM3CON | R/W | 8/16 | 00H |
| 0F03FH | Timer 3 control register 1 | TM3CON1 | | R/W | 8 | 00H |

9.2.2 Timer 0 Data Register (TM0D)

Address: 0F030H
Access: R/W
Access size: 8-bit
Initial value: 0FFH

| | 7 | 6 | 5 | 4 | 3 | 2 | 1 | 0 |
|---------------|------|------|------|------|------|------|------|------|
| TM0D | T0D7 | T0D6 | T0D5 | T0D4 | T0D3 | T0D2 | T0D1 | T0D0 |
| R/W | R/W | R/W | R/W | R/W | R/W | R/W | R/W | R/W |
| Initial value | 1 | 1 | 1 | 1 | 1 | 1 | 1 | 1 |

TM0D is a special function register (SFR) to set the value to be compared with the timer 0 counter register (TM0C) value.

Note:

Set TM0D when the timer stops(When T0STAT bit of TM0CON1 register is "0").
When "00H" is written in TM0D, TM0D is set to "01H".

9.2.3 Timer 1 Data Register (TM1D)

Address: 0F034H
Access: R/W
Access size: 8-bit
Initial value: 0FFH

| | 7 | 6 | 5 | 4 | 3 | 2 | 1 | 0 |
|---------------|------|------|------|------|------|------|------|------|
| TM1D | T1D7 | T1D6 | T1D5 | T1D4 | T1D3 | T1D2 | T1D1 | T1D0 |
| R/W | R/W | R/W | R/W | R/W | R/W | R/W | R/W | R/W |
| Initial value | 1 | 1 | 1 | 1 | 1 | 1 | 1 | 1 |

TM1D is a special function register (SFR) to set the value to be compared with the value of the timer 1 counter register (TM1C).

Note:

Set TM1D when the timer stops(When T1STAT bit of TM1CON1 register is "0").
When "00H" is written in TM1D, TM1D is set to "01H".

9.2.4 Timer 2 Data Register (TM2D)

Address: 0F038H
Access: R/W
Access size: 8-bit
Initial value: 0FFH

| | 7 | 6 | 5 | 4 | 3 | 2 | 1 | 0 |
|---------------|------|------|------|------|------|------|------|------|
| TM2D | T2D7 | T2D6 | T2D5 | T2D4 | T2D3 | T2D2 | T2D1 | T2D0 |
| R/W | R/W | R/W | R/W | R/W | R/W | R/W | R/W | R/W |
| Initial value | 1 | 1 | 1 | 1 | 1 | 1 | 1 | 1 |

TM2D is a special function register (SFR) to set the value to be compared with the value of the timer 2 counter register (TM2C).

Note:

Set TM2D when the timer stops(When T2STAT bit of TM2CON1 register is "0").
When "00H" is written in TM2D, TM2D is set to "01H".

9.2.5 Timer 3 Data Register (TM3D)

Address: 0F03CH
Access: R/W
Access size: 8-bit
Initial value: 0FFH

| | 7 | 6 | 5 | 4 | 3 | 2 | 1 | 0 |
|---------------|------|------|------|------|------|------|------|------|
| TM3D | T3D7 | T3D6 | T3D5 | T3D4 | T3D3 | T3D2 | T3D1 | T3D0 |
| R/W | R/W | R/W | R/W | R/W | R/W | R/W | R/W | R/W |
| Initial value | 1 | 1 | 1 | 1 | 1 | 1 | 1 | 1 |

TM3D is a special function register (SFR) to set the value to be compared with the value of the timer 3 counter register (TM3C).

Note:

Set TM3D when the timer stops(When T3STAT bit of TM3CON1 register is "0").
When "00H" is written in TM3D, TM3D is set to "01H".

9.2.6 Timer 0 Counter Register (TM0C)

Address: 0F031H
 Access: R/W
 Access size: 8-bit
 Initial value: 00H

| | | | | | | | | |
|---------------|------|------|------|------|------|------|------|------|
| | 7 | 6 | 5 | 4 | 3 | 2 | 1 | 0 |
| TM0C | T0C7 | T0C6 | T0C5 | T0C4 | T0C3 | T0C2 | T0C1 | T0C0 |
| R/W | R/W | R/W | R/W | R/W | R/W | R/W | R/W | R/W |
| Initial value | 0 | 0 | 0 | 0 | 0 | 0 | 0 | 0 |

TM0C is a special function register (SFR) that functions as an 8-bit binary counter. When write operation to TM0C is performed, TM0C is set to “00H”. The data that is written is meaningless. In 16-bit timer mode and 16-bit timer frequency measurement mode, if write operation is performed to either the low-order TM0C or high-order TM1C, both the low-order and the high-order are set to “0000H”.

During timer operation, the TM0C content may not be read depending on the conditions of the timer clock and the system clock.

Table 9-1 shows whether a TM0C read is enabled or disabled during timer operation for each condition of the timer clock and system clock.

Table 9-1 TM0C Read Enable/Disable during Timer Operation

| Timer clock T0CK | System clock SYSCLK | TM0C read enable/disable |
|---------------------|------------------------|--|
| LSCLK | LSCLK | Read enabled. |
| LSCLK | HSCLK | Read enabled. However, to prevent the reading of undefined data during incremental counting, read TM0C twice and check that the results match. |
| HTBCLK | LSCLK | Read disabled. |
| HTBCLK | HSCLK | Read enabled. |
| External clock | LSCLK | Read disabled. |
| | HSCLK | |

9.2.7 Timer 1 Counter Register (TM1C)

Address: 0F035H
Access: R/W
Access size: 8-bit
Initial value: 00H

| | | | | | | | | |
|---------------|------|------|------|------|------|------|------|------|
| | 7 | 6 | 5 | 4 | 3 | 2 | 1 | 0 |
| TM1C | T1C7 | T1C6 | T1C5 | T1C4 | T1C3 | T1C2 | T1C1 | T1C0 |
| R/W | R/W | R/W | R/W | R/W | R/W | R/W | R/W | R/W |
| Initial value | 0 | 0 | 0 | 0 | 0 | 0 | 0 | 0 |

TM1C is a special function register (SFR) that functions as an 8-bit binary counter.

When write operation to TM1C is performed, TM1C is set to "00H". The data that is written is meaningless.

In 16-bit timer mode, if write operation is performed to either the low-order TM0C or high-order TM1C, both the low order and the high order are set to "0000H".

When reading TM1C in 16-bit timer mode, be sure to read TM0C first since the count value of TM1C is stored in the TM1C latch when TM0C is read.

During timer operation, the TM1C content may not be read depending on the conditions of the timer clock and the system clock.

Table 9-2 shows whether a TM1C read is enabled or disabled during timer operation for each condition of the timer clock and system clock.

Table 9-2 TM1C Read Enable/Disable during Timer Operation

| Timer clock T1CK | System clock SYCLK | TM1C read enable/disable |
|---------------------|-----------------------|--|
| LSCLK | LSCLK | Read enabled. |
| LSCLK | HSCLK | Read enabled. However, to prevent the reading of undefined data during incremental counting, read TM1C twice and check that the results match. |
| HTBCLK | LSCLK | Read disabled. |
| HTBCLK | HSCLK | Read enabled. |
| External clock | LSCLK | Read disabled. |
| | HSCLK | |

9.2.8 Timer 2 Counter Register (TM2C)

Address: 0F039H
 Access: R/W
 Access size: 8-bit
 Initial value: 00H

| | | | | | | | | |
|---------------|------|------|------|------|------|------|------|------|
| | 7 | 6 | 5 | 4 | 3 | 2 | 1 | 0 |
| TM2C | T2C7 | T2C6 | T2C5 | T2C4 | T2C3 | T2C2 | T2C1 | T2C0 |
| R/W | R/W | R/W | R/W | R/W | R/W | R/W | R/W | R/W |
| Initial value | 0 | 0 | 0 | 0 | 0 | 0 | 0 | 0 |

TM2C is a special function register (SFR) that functions as an 8-bit binary counter.

When write operation to TM2C is performed, TM2C is set to “00H”. The data that is written is meaningless.

In 16-bit timer mode and 16-bit timer frequency measurement mode, if write operation is performed to either the low-order TM2C or high-order TM3C, both the low order and the high order are set to “0000H”.

During timer operation, the TM2C content may not be read depending on the conditions of the timer clock and the system clock.

Table 9-3 shows whether a TM2C read is enabled or disabled during timer operation for each condition of the timer clock and system clock.

Table 9-3 TM2C Read Enable/Disable during Timer Operation

| Timer clock T2CK | System clock SYSCLK | TM2C read enable/disable |
|---------------------|------------------------|--|
| LSCLK | LSCLK | Read enabled. |
| LSCLK | HSCLK | Read enabled. However, to prevent the reading of undefined data during incremental counting, read TM2C twice and check that the results match. |
| HTBCLK | LSCLK | Read disabled. |
| HTBCLK | HSCLK | Read enabled. |
| External clock | LSCLK | Read disabled. |
| | HSCLK | |

9.2.9 Timer 3 Counter Register (TM3C)

Address: 0F03DH
Access: R/W
Access size: 8-bit
Initial value: 00H

| | | | | | | | | |
|---------------|------|------|------|------|------|------|------|------|
| | 7 | 6 | 5 | 4 | 3 | 2 | 1 | 0 |
| TM3C | T3C7 | T3C6 | T3C5 | T3C4 | T3C3 | T3C2 | T3C1 | T3C0 |
| R/W | R/W | R/W | R/W | R/W | R/W | R/W | R/W | R/W |
| Initial value | 0 | 0 | 0 | 0 | 0 | 0 | 0 | 0 |

TM3C is a special function register (SFR) that functions as an 8-bit binary counter.

When write operation to TM3C is performed, TM3C is set to “00H”. The data that is written is meaningless.

In 16-bit timer mode and 16-bit timer frequency measurement mode, if write operation is performed to either the low-order (TM2C) or high-order (TM3C), both the low order and the high order are set to “0000H”.

When reading TM3C in 16-bit timer mode, be sure to read TM2C first since the count value of TM3C is stored in the TM3C latch when TM2C is read.

During timer operation, the TM3C content may not be read depending on the conditions of the timer clock and the system clock.

Table 9-4 shows whether a TM3C read is enabled or disabled during timer operation for each condition of the timer clock and system clock.

Table 9-4 TM3C Read Enable/Disable during Timer Operation

| Timer clock T3CK | System clock SYSCLK | TM3C read enable/disable |
|---------------------|------------------------|--|
| LSCLK | LSCLK | Read enabled. |
| LSCLK | HSCLK | Read enabled. However, to prevent the reading of undefined data during incremental counting, read TM3C twice and check that the results match. |
| HTBCLK | LSCLK | Read disabled. |
| HTBCLK | HSCLK | Read enabled. |
| External clock | LSCLK | Read disabled. |
| | HSCLK | |

9.2.10 Timer 0 Control Register 0 (TM0CON0)

Address: 0F032H
 Access: R/W
 Access size: 8-bit
 Initial value: 00H

| | | | | | | | | |
|---------------|-----|-----|-----|-----|-----|--------|-------|-------|
| | 7 | 6 | 5 | 4 | 3 | 2 | 1 | 0 |
| TM0CON0 | — | — | — | — | — | T01M16 | T0CS1 | T0CS0 |
| R/W | R/W | R/W | R/W | R/W | R/W | R/W | R/W | R/W |
| Initial value | 0 | 0 | 0 | 0 | 0 | 0 | 0 | 0 |

TM0CON0 is a special function register (SFR) to control the Timer 0.
 Rewrite TM0CON0 while the timer 0 is stopped (T0STAT of the TM0CON1 register is “0”).

[Description of Bits]

- **T0CS1, T0CS0** (bits 1, 0)
 The T0CS1 and T0CS0 bits are used for selecting the operation clock of timer 0. LSCLK, HTBCLK, or the external clock (P04/T02P0CK, P44/T02P0CK) can be selected by these bits.

| T0CS1 | T0CS0 | Description |
|-------|-------|------------------------------|
| 0 | 0 | LSCLK (initial value) |
| 0 | 1 | HTBCLK |
| 1 | 0 | External clock (P04/T02P0CK) |
| 1 | 1 | External clock (P44/T02P0CK) |

- **T01M16** (bit 2)
 The T01M16 bit is used for selecting the operating mode of timer 0 and timer 1.
 In 8-bit timer mode, each of timer 0 and timer 1 operates independently as a 8-bit timer.
 In 16-bit timer mode, timer 0 and timer 1 are connected and they operate as a 16-bit timer.
 In 16-bit timer mode, timer 1 is incremented by a timer 0 overflow signal.
 A timer 0 interrupt (TM0INT) is not generated.

| T01M16 | Description |
|--------|----------------------------------|
| 0 | 8-bit timer mode (initial value) |
| 1 | 16-bit timer mode |

9.2.11 Timer 1 Control Register 0 (TM1CON0)

Address: 0F036H
Access: R/W
Access size: 8-bit
Initial value: 00H

| | | | | | | | | |
|---------------|-----|-----|-----|-----|-----|-----|-------|-------|
| | 7 | 6 | 5 | 4 | 3 | 2 | 1 | 0 |
| TM1CON0 | — | — | — | — | — | — | T1CS1 | T1CS0 |
| R/W | R/W | R/W | R/W | R/W | R/W | R/W | R/W | R/W |
| Initial value | 0 | 0 | 0 | 0 | 0 | 0 | 0 | 0 |

TM1CON0 is a special function register (SFR) to control the Timer 1.
Rewrite TM1CON0 while the timer 1 is stopped (T1STAT of the TM1CON1 register is “0”).

[Description of Bits]

- **T1CS1, T1CS0** (bits 1, 0)
The T1CS1 and T1CS0 bits are used for selecting the operation clock of timer 1. LSCLK, HTBCLK, or the external clock (P45/T13CK) can be selected by these bits.
In cases where the 16-bit timer mode has been selected by setting T01M16 of TM0CON to “1”, the values of T1CS1 and T1CS0 are invalid.

| T1CS1 | T1CS0 | Description |
|-------|-------|----------------------------|
| 0 | 0 | LSCLK (initial value) |
| 0 | 1 | HTBCLK |
| 1 | 0 | Prohibited |
| 1 | 1 | External clock (P45/T13CK) |

9.2.12 Timer 2 Control Register 0 (TM2CON0)

Address: 0F03AH

Access: R/W

Access size: 8-bit

Initial value: A0H

| | 7 | 6 | 5 | 4 | 3 | 2 | 1 | 0 |
|---------------|--------|--------|--------|--------|--------|--------|-------|-------|
| TM2CON0 | T2FMA7 | T2FMA6 | T2FMA5 | T2FMA4 | T23MFM | T23M16 | T2CS1 | T2CS0 |
| R/W | R | R | R | R | R/W | R/W | R/W | R/W |
| Initial value | 1 | 0 | 1 | 0 | 0 | 0 | 0 | 0 |

TM2CON0 is a special function register (SFR) to control the Timer 2.

Rewrite TM2CON0 while the timer 2 is stopped (T2STAT of the TM2CON1 register is "0").

[Description of Bits]

- **T2CS1, T2CS0** (bits 1, 0)

The T2CS1 and T2CS0 bits are used for selecting the operation clock of timer 2. LSCLK, HTBCLK, or the external clock (P04/T02P0CK, P44/T02P0CK) can be selected by these bits.

| T2CS1 | T2CS0 | Description |
|-------|-------|------------------------------|
| 0 | 0 | LSCLK (initial value) |
| 0 | 1 | HTBCLK |
| 1 | 0 | External clock (P04/T02P0CK) |
| 1 | 1 | External clock (P44/T02P0CK) |

- **T23MFM, T23M16** (bit 3, 2)

The T23MFM bit and T23M16 bit is used for selecting the operating mode of timer 2 and timer 3..

In 8-bit timer mode, each of timer 0 and timer 1 operates independently as a 8-bit timer.

In 16-bit timer mode, timer 2 and timer 3 are connected and they operate as a 16-bit timer.

In 16-bit timer mode, timer 3 is incremented by a timer 2 overflow signal.

A timer 2 interrupt (TM2INT) is not generated.

In 16-bit timer frequency measurement mode, timer 2 and timer 3 are connected and they operate as a 16-bit clock counter to measure the frequency.

A timer 2 interrupt (TM2INT) is not generated.

When this LSI does not have the frequency measurement function (T2FMA7 to T2FMA5 bit values are not "1010"),

the T23MFM bit is read-only and the readout is always "0" regardless of the write access value.

| T23MFM | T23M16 | Description |
|--------|--------|---|
| 0 | 0 | 8-bit timer mode (initial value) |
| 0 | 1 | 16-bit timer mode |
| 1 | 0 | Prohibited |
| 1 | 1 | 16-bit timer frequency measurement mode |

- **T2FMA7 to T2FMA4** (bit 7 to 4)

T2FMA7 to T2FMA4 are read-only registers that show whether the frequency measurement function is provided.

The readout is always "0A".

| T2FMA7 | T2FMA6 | T2FMA5 | T2FMA4 | Description |
|--------|--------|--------|--------|---|
| 1 | 0 | 1 | 0 | The frequency measurement mode is available |

9.2.13 Timer 3 Control Register 0 (TM3CON0)

Address: 0F03EH
Access: R/W
Access size: 8-bit
Initial value: 00H

| | | | | | | | | |
|---------------|-----|-----|-----|-----|-----|-----|-------|-------|
| | 7 | 6 | 5 | 4 | 3 | 2 | 1 | 0 |
| TM3CON0 | — | — | — | — | — | — | T3CS1 | T3CS0 |
| R/W | R/W | R/W | R/W | R/W | R/W | R/W | R/W | R/W |
| Initial value | 0 | 0 | 0 | 0 | 0 | 0 | 0 | 0 |

TM3CON0 is a special function register (SFR) to control the Timer 3.
Rewrite TM3CON0 while the timer 3 is stopped (T3STAT of the TM3CON1 register is “0”).

[Description of Bits]

- **T3CS1, T3CS0** (bits 1, 0)
The T3CS1 and T3CS0 bits are used for selecting the operation clock of timer 3. LSCLK, HTBCLK, or the external clock (P44/T13CK) can be selected by these bits.
In cases where the 16-bit timer mode has been selected by setting T23M16 of TM2CON to “1”, the values of T3CS1 and T3CS0 are invalid.

| T3CS1 | T3CS0 | Description |
|-------|-------|----------------------------|
| 0 | 0 | LSCLK (initial value) |
| 0 | 1 | HTBCLK |
| 1 | 0 | Prohibited |
| 1 | 1 | External clock (P45/T13CK) |

9.2.14 Timer 0 Control Register 1 (TM0CON1)

Address: 0F033
 Access: R/W
 Access size: 8-bit
 Initial value: 00H

| | | | | | | | | |
|---------------|--------|-----|-----|-----|-----|-----|-----|-------|
| | 7 | 6 | 5 | 4 | 3 | 2 | 1 | 0 |
| TM0CON1 | T0STAT | — | — | — | — | — | — | T0RUN |
| R/W | R | R/W | R/W | R/W | R/W | R/W | R/W | R/W |
| Initial value | 0 | 0 | 0 | 0 | 0 | 0 | 0 | 0 |

TM0CON1 is a special function register (SFR) to control the Timer 0.

[Description of Bits]

- **T0RUN** (bit 0)
 The T0RUN bit is used for controlling stop/start of timer 0.

| T0RUN | Description |
|-------|------------------|
| 0 | Stops counting. |
| 1 | Starts counting. |

- **T0STAT** (bit 7)
 The T0STAT bit is used for indicating “counting stopped”/”counting in progress” of timer 0.

| T0STAT | Description |
|--------|-----------------------|
| 0 | Counting stopped. |
| 1 | Counting in progress. |

9.2.15 Timer 1 Control Register 1 (TM1CON1)

Address: 0F037H
Access: R/W
Access size: 8-bit
Initial value: 00H

| | | | | | | | | |
|---------------|--------|-----|-----|-----|-----|-----|-----|-------|
| | 7 | 6 | 5 | 4 | 3 | 2 | 1 | 0 |
| TM1CON1 | T1STAT | — | — | — | — | — | — | T1RUN |
| R/W | R | R/W | R/W | R/W | R/W | R/W | R/W | R/W |
| Initial value | 0 | 0 | 0 | 0 | 0 | 0 | 0 | 0 |

TM1CON1 is a special function register (SFR) to control the Timer 1.

[Description of Bits]

- **T1RUN** (bit 0)

The T1RUN bit is used for controlling count stop/start of timer 1.

In 16-bit timer mode, be sure to set this bit to “0”. Regardless of the T1RUN value, the Timer 1 counts up by the Timer 0 overflow signal.

| T1RUN | Description |
|-------|------------------|
| 0 | Stops counting. |
| 1 | Starts counting. |

- **T1STAT** (bit 7)

The T1STAT bit is used for indicating “counting stopped”/”counting in progress” of timer 1.

In 16-bit timer mode, this bit will read “0”.

| T1STAT | Description |
|--------|-----------------------|
| 0 | Counting stopped. |
| 1 | Counting in progress. |

9.2.16 Timer 2 Control Register 1 (TM2CON1)

Address: 0F03BH
 Access: R/W
 Access size: 8-bit
 Initial value: 00H

| | | | | | | | | |
|---------------|--------|-----|-----|-----|-----|-----|-----|-------|
| | 7 | 6 | 5 | 4 | 3 | 2 | 1 | 0 |
| TM2CON1 | T2STAT | — | — | — | — | — | — | T2RUN |
| R/W | R | R/W | R/W | R/W | R/W | R/W | R/W | R/W |
| Initial value | 0 | 0 | 0 | 0 | 0 | 0 | 0 | 0 |

TM2CON1 is a special function register (SFR) to control the Timer 2.

[Description of Bits]

- **T2RUN** (bit 0)
 The T2RUN bit is used for controlling stop/start of timer 2.
 Setting the T2RUN bit can force cancel the counting in the 16-bit timer frequency measurement mode.
 In that case, TM3INT does not occur.

| T2RUN | Description |
|-------|---|
| 0 | In timer mode: Stops counting. In frequency measurement mode: Stops measurement |
| 1 | In timer mode: Starts counting. In frequency measurement mode: Starts measurement |

- **T2STAT** (bit 7)
 The T2STAT bit is used for indicating “counting stopped”/”counting in progress” of timer 2.

| T2STAT | Description |
|--------|--|
| 0 | In timer mode: Count halted. In frequency measurement mode: Measurement halted |
| 1 | In timer mode: Counting in progress. In frequency measurement mode: Measuring |

9.2.17 Timer 3 Control Register 1 (TM3CON1)

Address: 0F03FH
Access: R/W
Access size: 8-bit
Initial value: 00H

| | | | | | | | | |
|---------------|--------|-----|-----|-----|-----|-----|-----|-------|
| | 7 | 6 | 5 | 4 | 3 | 2 | 1 | 0 |
| TM3CON1 | T3STAT | — | — | — | — | — | — | T3RUN |
| R/W | R | R/W | R/W | R/W | R/W | R/W | R/W | R/W |
| Initial value | 0 | 0 | 0 | 0 | 0 | 0 | 0 | 0 |

TM3CON1 is a special function register (SFR) to control the Timer 3.

[Description of Bits]

- **T3RUN** (bit 0)

The T3RUN bit is used for controlling stop/start of timer 3.

In 16-bit timer mode and 16-bit timer frequency measurement mode, be sure to set this bit to “0”. Regardless of the T3RUN value, the Timer 3 counts up by the Timer 2 overflow signal.

In 16-bit timer frequency measurement mode, be sure to set this bit to “0” also.

| T3RUN | Description |
|-------|------------------|
| 0 | Stops counting. |
| 1 | Starts counting. |

- **T3STAT** (bit 7)

The T3STAT bit is used for indicating “counting stopped”/”counting in progress” of timer 3.

In 16-bit timer mode and 16-bit timer frequency measurement mode, this bit will return “0”.

| T3STAT | Description |
|--------|-----------------------|
| 0 | Counting stopped. |
| 1 | Counting in progress. |

9.3 Description of Operation

9.3.1 Timer mode operation

The timer counters (TMnC) are set to an operating state (TnSTAT are set to “1”) on the first falling edge of the timer clocks (TnCK) that are selected by the Timer 0 to 3 control register 0 (TMnCON0) when the TnRUN bits of timer 0 to 3 control register 1 (TMnCON1) are set to “1” and increment the count value on the 2nd falling.

When the count value of TM0 to TM3C and the timer 0 to 3 data register (TMnD) coincide, timer 0 to 3 interrupt (TMnINT) occurs on the next timer clock falling edge, TMnC are reset to “00H” and incremental counting continues.

When the TnRUN bits are set to “0”, TMnC stop counting after counting once the falling of the timer clock (TnCK). Confirm that TMnC has been stopped by checking that the TnSTAT bit of the Timer 0–3 control register 1 (TMnCON1) is “0”.

When the TnRUN bits are set to “1” again, TMn restart incremental counting from the previous values. To initialize TMnC to “00H”, perform write operation in TMnC.

The timer interrupt period (T_{TMI}) is expressed by the following equation.

$$T_{TMI} = \frac{TMnD + 1}{TnCK \text{ (Hz)}} \quad (n=0 \sim 3)$$

TMnD: Timer 0 to 3 data register (TMnD) setting value (01H to 0FFH)

TnCK: Clock frequency selected by the Timer 0 to 3 control register 0 (TMnCON0)

After the TnRUN bits are set to “1”, timers are synchronized by the timer clock and counting starts so that an error of a maximum of 1 clock period occurs until the first timer interrupt. The timer interrupt periods from the second time are constant.

Figure 9-2 shows the operation timing diagram of Timer 0 to 3.

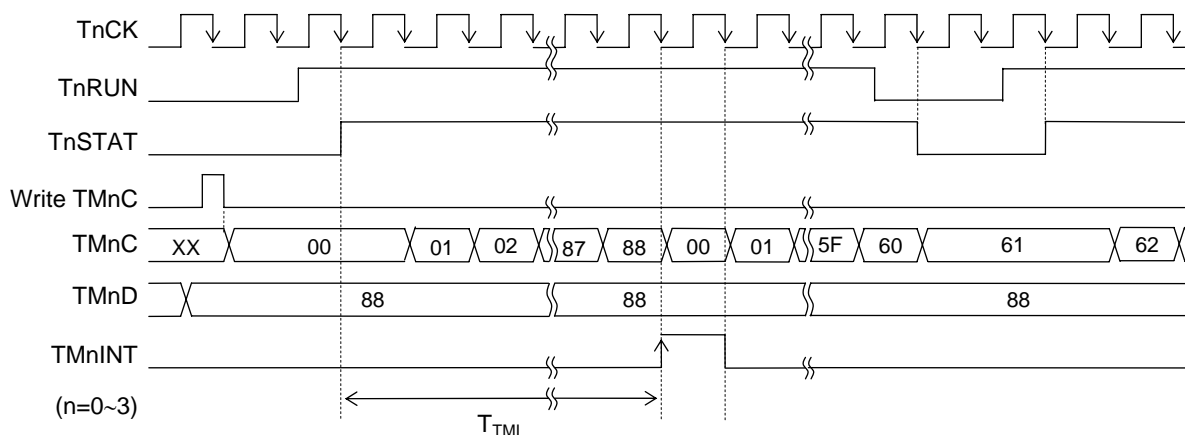

Figure 9-2 Operation Timing Diagram of Timer 0 to 3

Note:

Even if “0” is written to the TnRUN bits, counting operation continues up to the falling edge (the timer 0 to 3 status flag (TnSTA) is in a “1” state) of the next timer clock pulse. Therefore, the timer 0 to 3 interrupt (TMnINT) may occur.

9.3.2 16-bit timer frequency measurement mode operation

The frequency measurement mode in 16-bit timer 2&3, is used to count the frequency of 500kHz RC oscillation clock which typically has temperature variation and production tolerance.

Using the frequency measurement mode can make better accuracy for uart baud-rate clock or timer function.

- (1) Reading the count data, calculating and setting it to uart communication baud-rate registers, can make more accurate baud-rate clock.
- (2) Reading the count data, calculating and setting it to a timer data register, can make more accurate timing in normal timer mode.

Figure 9-3 shows the operation timing in frequency measurement mode.

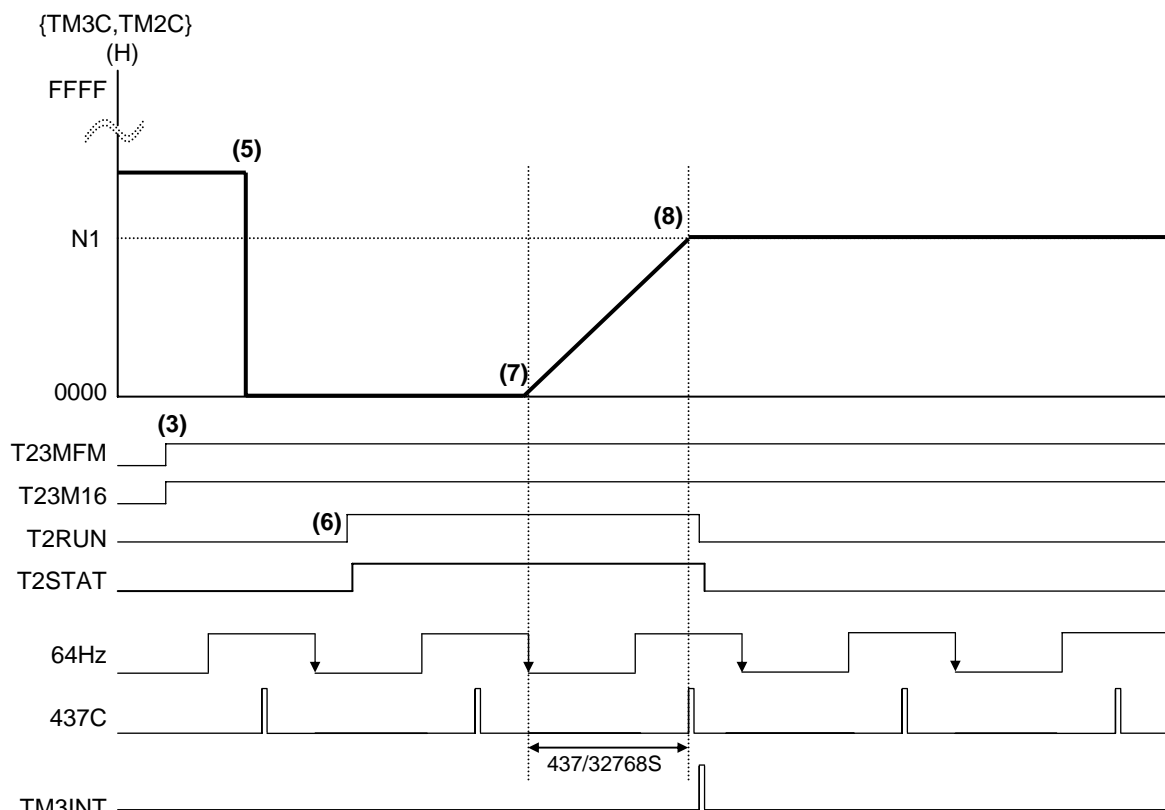

Figure 9-3 Operation Timing in frequency measurement mode

(1) High-speed clock (HSCLK, HTBCLK) has to be in oscillating state by controlling with FCONn registers. And also select 1/1 divide ratio of the high-speed time base counter by setting HTBDR (High-speed Time Base counter Divide Register) register to 0FH.

(2) Reset both T2RUN bit (bit0 of TM2CON1 register) and T3RUN bit (bit0 of TM3CON1 register) to “0” to stop the timer. And then, check both T2STAT bit (bit7 of TM2CON1 register) and T3STAT bit (bit7 of TM3CON1 register) are “0” for making certain the timer stops.

(3) Set T23MFM bit (bit3 of TM2CON0 register) to “1” (Frequency measurement mode), set T23M16 bit (bit2 of TM2CON0 register) to “1” (16bit mode) and set T2CS1-0 bits(bit1/0 of TM2CON0 register) to “01”(HTBCLK mode).

(4) Set “FFH” to both TM2D register and TM3D register.

(5) Clear both TM2C register and TM3C register to “00H”.

(6) Set T2RUN bit (bit0 of TM2CON1 register) to “1” to start counting the timer.

- (7) When (T23MFM bit == "1") and (TM23M16 bit == "1") and (T2RUN bit == "1"), the count up starts with the falling of the 64Hz clock signal.
- (8) The count-up stops at the falling edge of the next timer clock (HTBCLK) after 437C signal becomes "1". Also, at the same time, T2RUN bit and T2STAT bit become "0" and the interrupt signal TM3INT activates. The 437C signal is the pulse signal that rises in 437/32768 seconds after the falling of the 64Hz signal.
- (9) After checking T2STAT bit or TM3INT interrupt occurs, read out the data (N1) of TM2C register and TM3C register.

For example of utilizing N1, 9600Hz timer interrupt is generated.

Assuming a low-accuracy high-speed clock (HTBCLK) is exactly 600kHz, then the count value N1 is:

$$\begin{aligned} N1 &= 600000 \times 437 / 32768 \\ &= 8001 \text{ (Decimal)} \\ &= 1F41 \text{ (Hexadecimal)} \\ &= 0001\ 1111\ 0100\ 0001 \text{ (Binary)} \end{aligned}$$

Because 437/32768 seconds are equivalent to 128 clocks at 9600 Hz (more precisely, 9598 Hz), dividing the count value NI by 128 provides the frequency ratio (N2) between the HTBCLK and 9600 Hz.

Because $128 = 2^7$, this calculation can be solved by truncating the right-hand seven digits of N1 (Binary), that is:

$$\begin{aligned} N2 &= 8001(\text{Decimal}) / 128 (\text{Decimal}) \\ &= 0001\ 1111\ 0 (\text{Binary}) \\ &= 3E (\text{Hexadecimal}) \\ &= 62 (\text{Decimal}) \end{aligned}$$

This indicates that 9600Hz is about 62 times the cycle of HTBCLK.

Therefore, for an operation in the timer mode where the timer data register is set to $3EH - 1 = 3DH$ to overflow the counter every 62 counts of the HTBCLK clock, the TMnINT interrupt signal cycle tTMnINT is:

$$tTMnINT = 1 / 600000 \times 62 = 0.10333\text{ms}(9677\text{Hz})$$

9.3.3 16-bit timer frequency measurement mode application for setting uart baud-rate

For example, when the target baud-rate is 9600bps and the clock is HSCLK(500kHz), the UART0 baud-rate register (UA0BRTH, UA0BRTL) should be set as:

$$UA0BRTH, UA0BRTL = 500000/9600 - 1 = 51 \text{ (decimal)} = 33 \text{ (hexadecimal)} \text{ (See Section 14.3.2.)}$$

However, actual 500kHz RC oscillation clock has temperature variation and production tolerance, the calculation by using the fixed value of 500kHz cannot make accurate baud-rate. To compensate it, count the frequency in the frequency measurement mode to set the baud-rate again before operating UART communication.

After finishing the clock count in the frequency measurement mode, assuming HTBCLK is 451kHz, data of TM2C register and TM3C register will be:

$$\begin{aligned} N1 &= 451000 \times 437 / 32768 \\ &= 6014 \text{ (Decimal)} \\ &= 177E \text{ (Hexadecimal)} \\ &= 1011101111110 \text{ (Binary)} \end{aligned}$$

As (437 / 32768) sec is equivalent to 128 clocks at 9600Hz (more precisely, 9598Hz), a division of the count (N1) by 128 equals frequency ratio (N2) between the frequency of HTBCLK and 9600Hz. For the calculation, the accuracy of baud-rate depends on truncating (1) or rounding (2) the data.

UART0 baud rate registers H and L are:

$$UA0BRTH, UA0BRTL = (\text{frequency ratio between HTBCLK clock and baud rate}) - 1 = (N1/128)-1 = N2 - 1$$

(See Section 14.3.2.)

① Round data in calculation

$$N1 = 1011101111110 \text{ (binary)}$$

$$N2 = 101111 \text{ (binary)} = 47 \text{ (decimal)} = 2F \text{ (hexadecimal)}$$

Set N2-1 (= 2E) to UA0BRTH and UA0BRTL registers. In this case, the actual baud-rate will be 9595.744681.. [bps], so the accuracy = ((9595.744681/9600) - 1)* 100= -0.04..[%].

② Truncate data in calculation (the accuracy of baud-rate becomes worse)

$$N1 = 1011101111110 \text{ (binary)}$$

$$N2 = 101110 \text{ (binary)} = 46 \text{ (decimal)} = 2E \text{ (hexadecimal)}$$

Set N2-1 (= 2D) to UA0BRTH and UA0BRTL registers. In this case, the actual baud-rate will be 9804.347826.. [bps], so the accuracy = ((9804.347826/9600) - 1)* 100= 2.12..[%].

Table 9-5 shows the baud rate and accuracy (theoretical) when the baud rate clock is set to 500KHz. Table 9-6 shows the baud rate and accuracy (theoretical) when the baud rate clock is set to 2MHz.

Table 9-5 Baud Rate and Accuracy (theoretical) for Baud Rate Clock Set to 500KHz

| Baud-rate[bps] | Data setting to UA0BRTH register and UA0BRTL register | Theoretical accuracy |
|----------------|---|----------------------|
| 300 | Round off {N1/4 (2bit right-shift) } - (minus) 1. | less than ±2% |
| 600 | Round off {N1/8 (3bit right-shift) } - (minus) 1. | |
| 1200 | Round off {N1/16 (4bit right-shift) } - (minus) 1. | |
| 2400 | Round off {N1/32 (5bit right-shift) } - (minus) 1. | |
| 4800 | Round off {N1/64 (6bit right-shift) } - (minus) 1. | |
| 9600 | Round off {N1/128 (7bit right-shift) } - (minus) 1. | ±2% to 2.5% |
| 19200 | Round off {N1/256 (8bit right-shift) } - (minus) 1. | |
| 38400 | Round off {N1/512 (9bit right-shift) } - (minus) 1. | |

Table 9-6 Baud Rate and Accuracy (theoretical) for Baud Rate Clock Set to 2MHz

| Baud-rate[bps] | Data setting to UA0BRTH register and UA0BRTN register | Theoretical accuracy |
|----------------|---|----------------------|
| 300 | Round off $\{N1/4 \text{ (2bit right-shift)}\} - (\text{minus}) 1.$ | less than $\pm 2\%$ |
| 600 | Round off $\{N1/8 \text{ (3bit right-shift)}\} - (\text{minus}) 1.$ | |
| 1200 | Round off $\{N1/16 \text{ (4bit right-shift)}\} - (\text{minus}) 1.$ | |
| 2400 | Round off $\{N1/32 \text{ (5bit right-shift)}\} - (\text{minus}) 1.$ | |
| 4800 | Round off $\{N1/64 \text{ (6bit right-shift)}\} - (\text{minus}) 1.$ | |
| 9600 | Round off $\{N1/128 \text{ (7bit right-shift)}\} - (\text{minus}) 1.$ | |
| 19200 | Round off $\{N1/256 \text{ (8bit right-shift)}\} - (\text{minus}) 1.$ | |
| 38400 | Round off $\{N1/512 \text{ (9bit right-shift)}\} - (\text{minus}) 1.$ | |

9.4 Operating Timers by External Clock Inputs

When the external clock is selected as the operation clock for the Timer 0 (8-bit timer mode), operate it by inputting the clock from the P04 or with the P44 set to the 1st function. When the external clock is selected as the operation clock for the Timer 1 (8-bit timer mode), operate it by inputting the clock with the P45 set to the 1st function. When the external clock is selected as the operation clock for the Timer 2 (8-bit timer mode), operate it by inputting the clock from the P04 or with the P44 set to the 1st function. When the external clock is selected as the operation clock for the Timer 3 (8-bit timer mode), operate it by inputting the clock with the P45 set to the 1st function.

When the external clock is selected as the operation clock for the Timers 0 and 1 set to the 16-bit timer mode, operate them by inputting the clock from the P04. When the external clock is selected as the operation clock for the Timers 2 and 3 set to the 16-bit timer mode, operate them by inputting the clock with the P44 set to the 1st function.

Set the external clock frequency to a value below the operating frequency (fop) in "Appendix C Electrical Characteristics."

9.4.1 Operating Timer 0 (8-Bit Timer Mode) by External Clock (P04/T02P0CK)

Select the external clock(P04/T02P0CK) and timer0 (8-bit mode) in the TM0CON0 register, And input the operation clock for the Timer 0 from the P04 pin.

9.4.2 Operating Timer 0 (8-Bit Timer Mode) by External Clock (P44/T02P0CK)

Set the P44MD1 bit (P4MOD1 register's bit 4) to "0" and the P44MD0 bit (P4MOD0 register's bit 4) to "0" for specifying the P44 to the 1st function.

| Register name | P4MOD1 register (Address: 0F225H) | | | | | | | |
|---------------|-----------------------------------|--------|--------|---------------|--------|--------|--------|--------|
| Bit | 7 | 6 | 5 | 4 | 3 | 2 | 1 | 0 |
| Bit name | P47MD1 | P46MD1 | P45MD1 | P44MD1 | P43MD1 | P42MD1 | P41MD1 | P40MD1 |
| Setting value | * | * | * | 0 | * | * | * | * |

| Register name | P4MOD0 register (Address: 0F224H) | | | | | | | |
|---------------|-----------------------------------|--------|--------|---------------|--------|--------|--------|--------|
| Bit | 7 | 6 | 5 | 4 | 3 | 2 | 1 | 0 |
| Bit name | P47MD0 | P46MD0 | P45MD0 | P44MD0 | P43MD0 | P42MD0 | P41MD0 | P40MD0 |
| Setting value | * | * | * | 0 | * | * | * | * |

Set the P44DIR bit (P4DIR register's bit 4) to "1" for specifying the state mode of the P44 pin to input.

| Register name | P4DIR register (Address: 0F221H) | | | | | | | |
|---------------|----------------------------------|--------|--------|---------------|--------|--------|--------|--------|
| Bit | 7 | 6 | 5 | 4 | 3 | 2 | 1 | 0 |
| Bit name | P47DIR | P46DIR | P45DIR | P44DIR | P43DIR | P42DIR | P41DIR | P40DIR |
| Setting value | * | * | * | 1 | * | * | * | * |

Select the external clock(P44/T02P0CK) and timer0 (8-bit mode) in the TM0CON0 register, and input the operation clock for the Timer 0 from the P44 pin.

9.4.3 Operating Timer 1 (8-Bit Timer Mode) by External Clock (P45/T13CK)

Set the P45MD1 bit (P4MOD1 register's bit 5) to "0" and the P45MD0 bit (P4MOD0 register's bit 5) to "0" for specifying the P45 to the 1st function.

| Register name | P4MOD1 register (Address: 0F225H) | | | | | | | |
|---------------|-----------------------------------|--------|---------------|--------|--------|--------|--------|--------|
| Bit | 7 | 6 | 5 | 4 | 3 | 2 | 1 | 0 |
| Bit name | P47MD1 | P46MD1 | P45MD1 | P44MD1 | P43MD1 | P42MD1 | P41MD1 | P40MD1 |
| Setting value | * | * | 0 | * | * | * | * | * |

| Register name | P4MOD0 register (Address: 0F224H) | | | | | | | |
|---------------|-----------------------------------|--------|---------------|--------|--------|--------|--------|--------|
| Bit | 7 | 6 | 5 | 4 | 3 | 2 | 1 | 0 |
| Bit name | P47MD0 | P46MD0 | P45MD0 | P44MD0 | P43MD0 | P42MD0 | P41MD0 | P40MD0 |
| Setting value | * | * | 0 | * | * | * | * | * |

Set the P45DIR bit (P4DIR register's bit 5) to "1" for specifying the state mode of the P45 pin to input.

| Register name | P4DIR register (Address: 0F221H) | | | | | | | |
|---------------|----------------------------------|--------|---------------|--------|--------|--------|--------|--------|
| Bit | 7 | 6 | 5 | 4 | 3 | 2 | 1 | 0 |
| Bit name | P47DIR | P46DIR | P45DIR | P44DIR | P43DIR | P42DIR | P41DIR | P40DIR |
| Setting value | * | * | 1 | * | * | * | * | * |

Select the external clock(P45/T13CK) and timer1 (8-bit mode) in the TM0CON0 and TM1CON0 register, and input the operation clock for the Timer 1 from the P45 pin.

9.4.4 Operating Timer 2 (8-Bit Timer Mode) by External Clock (P04/T02P0CK)

Select the external clock(P04/T02P0CK) and timer2 (8-bit mode) in the TM2CON0 register, and input the operation clock for the Timer 2 from the P04 pin.

9.4.5 Operating Timer 2 (8-Bit Timer Mode) by External Clock (P44/T02P0CK)

Set the P44MD1 bit (P4MOD1 register's bit 4) to "0" and the P44MD0 bit (P4MOD0 register's bit 4) to "0" for specifying the P44 to the 1st function.

| Register name | P4MOD1 register (Address: 0F225H) | | | | | | | |
|---------------|-----------------------------------|--------|--------|---------------|--------|--------|--------|--------|
| Bit | 7 | 6 | 5 | 4 | 3 | 2 | 1 | 0 |
| Bit name | P47MD1 | P46MD1 | P45MD1 | P44MD1 | P43MD1 | P42MD1 | P41MD1 | P40MD1 |
| Setting value | * | * | * | 0 | * | * | * | * |

| Register name | P4MOD0 register (Address: 0F224H) | | | | | | | |
|---------------|-----------------------------------|--------|--------|---------------|--------|--------|--------|--------|
| Bit | 7 | 6 | 5 | 4 | 3 | 2 | 1 | 0 |
| Bit name | P47MD0 | P46MD0 | P45MD0 | P44MD0 | P43MD0 | P42MD0 | P41MD0 | P40MD0 |
| Setting value | * | * | * | 0 | * | * | * | * |

Set the P44DIR bit (P4DIR register's bit 4) to "1" for specifying the state mode of the P44 pin to input.

| Register name | P4DIR register (Address: 0F221H) | | | | | | | |
|---------------|----------------------------------|--------|--------|---------------|--------|--------|--------|--------|
| Bit | 7 | 6 | 5 | 4 | 3 | 2 | 1 | 0 |
| Bit name | P47DIR | P46DIR | P45DIR | P44DIR | P43DIR | P42DIR | P41DIR | P40DIR |
| Setting value | * | * | * | 1 | * | * | * | * |

Select the external clock(P44/T02P0CK) and timer2 (8-bit mode) in the TM2CON0 register, and input the operation clock for the Timer 2 from the P44 pin.

9.4.6 Operating Timer 3 (8-Bit Timer Mode) by External Clock (P45/T13CK)

Set the P45MD1 bit (P4MOD1 register's bit 5) to "0" and the P45MD0 bit (P4MOD0 register's bit 5) to "0" for specifying the P45 to the 1st function.

| Register name | P4MOD1 register (Address: 0F225H) | | | | | | | |
|---------------|-----------------------------------|--------|---------------|--------|--------|--------|--------|--------|
| Bit | 7 | 6 | 5 | 4 | 3 | 2 | 1 | 0 |
| Bit name | P47MD1 | P46MD1 | P45MD1 | P44MD1 | P43MD1 | P42MD1 | P41MD1 | P40MD1 |
| Setting value | * | * | 0 | * | * | * | * | * |

| Register name | P4MOD0 register (Address: 0F224H) | | | | | | | |
|---------------|-----------------------------------|--------|---------------|--------|--------|--------|--------|--------|
| Bit | 7 | 6 | 5 | 4 | 3 | 2 | 1 | 0 |
| Bit name | P47MD0 | P46MD0 | P45MD0 | P44MD0 | P43MD0 | P42MD0 | P41MD0 | P40MD0 |
| Setting value | * | * | 0 | * | * | * | * | * |

Set the the P45DIR bit (P4DIR register's bit 5) to "1" for specifying the state mode of the P45 pin to input.

| Register name | P4DIR register (Address: 0F221H) | | | | | | | |
|---------------|----------------------------------|--------|---------------|--------|--------|--------|--------|--------|
| Bit | 7 | 6 | 5 | 4 | 3 | 2 | 1 | 0 |
| Bit name | P47DIR | P46DIR | P45DIR | P44DIR | P43DIR | P42DIR | P41DIR | P40DIR |
| Setting value | * | * | 1 | * | * | * | * | * |

Select the external clock(P45/T13CK) and timer3 (8-bit mode) in the TM3CON0 register, and input the operation clock for the Timer 3 from the P45 pin.

9.4.7 Operating Timer 0 and Timer 1 (16-Bit Timer Mode) by External Clock (P04/T02P0CK)

Select the external clock(P04/T02P0CK) and Timers 0 and 1 (16-bit mode) in the TM0CON0 register, and input the operation clock for the Timers 0 and 1 (16-bit mode) from the P04 pin.

9.4.8 Operating Timer 0 and Timer 1 (16-Bit Timer Mode) by External Clock (P44/T02P0CK)

Set the P44MD1 bit (P4MOD1 register's bit 4) to "0" and the P44MD0 bit (P4MOD0 register's bit 4) to "0" for specifying the P44 to the 1st function.

| Register name | P4MOD1 register (Address: 0F225H) | | | | | | | |
|---------------|-----------------------------------|--------|--------|---------------|--------|--------|--------|--------|
| Bit | 7 | 6 | 5 | 4 | 3 | 2 | 1 | 0 |
| Bit name | P47MD1 | P46MD1 | P45MD1 | P44MD1 | P43MD1 | P42MD1 | P41MD1 | P40MD1 |
| Setting value | * | * | * | 0 | * | * | * | * |

| Register name | P4MOD0 register (Address: 0F224H) | | | | | | | |
|---------------|-----------------------------------|--------|--------|---------------|--------|--------|--------|--------|
| Bit | 7 | 6 | 5 | 4 | 3 | 2 | 1 | 0 |
| Bit name | P47MD0 | P46MD0 | P45MD0 | P44MD0 | P43MD0 | P42MD0 | P41MD0 | P40MD0 |
| Setting value | * | * | * | 0 | * | * | * | * |

Set the P44DIR bit (P4DIR register's bit 4) to "1" for specifying the state mode of the P44 pin to input.

| Register name | P4DIR register (Address: 0F221H) | | | | | | | |
|---------------|----------------------------------|--------|--------|---------------|--------|--------|--------|--------|
| Bit | 7 | 6 | 5 | 4 | 3 | 2 | 1 | 0 |
| Bit name | P47DIR | P46DIR | P45DIR | P44DIR | P43DIR | P42DIR | P41DIR | P40DIR |
| Setting value | * | * | * | 1 | * | * | * | * |

Select the external clock(P44/T02P0CK) and Timers 0 and 1 (16-bit mode) in the TM0CON0 register, and input the operation clock for the Timers 0 and 1 (16-bit mode) from the P44 pin.

9.4.9 Operating Timer 2 and Timer 3 (16-Bit Timer Mode) by External Clock (P44/T02P0CK)

Set the P44MD1 bit (P4MOD1 register's bit 4) to "0" and the P44MD0 bit (P4MOD0 register's bit 4) to "0" for specifying the P44 to the 1st function.

| Register name | P4MOD1 register (Address: 0F225H) | | | | | | | |
|---------------|-----------------------------------|--------|--------|---------------|--------|--------|--------|--------|
| Bit | 7 | 6 | 5 | 4 | 3 | 2 | 1 | 0 |
| Bit name | P47MD1 | P46MD1 | P45MD1 | P44MD1 | P43MD1 | P42MD1 | P41MD1 | P40MD1 |
| Setting value | * | * | * | 0 | * | * | * | * |

| Register name | P4MOD0 register (Address: 0F224H) | | | | | | | |
|---------------|-----------------------------------|--------|--------|---------------|--------|--------|--------|--------|
| Bit | 7 | 6 | 5 | 4 | 3 | 2 | 1 | 0 |
| Bit name | P47MD0 | P46MD0 | P45MD0 | P44MD0 | P43MD0 | P42MD0 | P41MD0 | P40MD0 |
| Setting value | * | * | * | 0 | * | * | * | * |

Set the P44DIR bit (P4DIR register's bit 4) to "1" for specifying the state mode of the P44 pin to input.

| Register name | P4DIR register (Address: 0F221H) | | | | | | | |
|---------------|----------------------------------|--------|--------|---------------|--------|--------|--------|--------|
| Bit | 7 | 6 | 5 | 4 | 3 | 2 | 1 | 0 |
| Bit name | P47DIR | P46DIR | P45DIR | P44DIR | P43DIR | P42DIR | P41DIR | P40DIR |
| Setting value | * | * | * | 1 | * | * | * | * |

Select the external clock(P44/T02P0CK) and Timers 2 and 3 (16-bit mode) in the TM2CON0 register, and input the operation clock for the Timers 2 and 3 (16-bit mode) from the P44 pin.

Chapter 10

PWM

10. PWM

10.1 Overview

This LSI includes one channel of 16-bit PWM (Pulse Width Modulation).

The PWM output (PWM0) is assigned to the tertiary function of the P43 (Port 4) or the secondary function of the P24 (Port 2). For the functions of Port 4 and Port 2, see Chapter 17, "Port 4" and Chapter 15, "Port 2".

10.1.1 Features

- Capable of generating and externally outputting a PWM signal at a cycle ranging from 2000ns (@HTBCLK = 500kHz) to 2s (@LSCLK = 32.768kHz)(*)
- The output logic of the PWM signal can be switched to the positive or negative logic.
- At the coincidence of PWM signal period, duties, and period & duty, a PWM interrupt (PW0INT) occurs.
- For the PWM clock, a low-speed clock (LSCLK), a high-speed time base clock (HTBCLK), and an external clock are available.

(*) For HSCLK 2MHz, the cycle ranges from 500ns (@HTBCLK=2MHz) to 2s (@LSCLK=32.768kHz).

10.1.2 Configuration

Figure 10 - 1 shows the configuration of the PWM circuit.

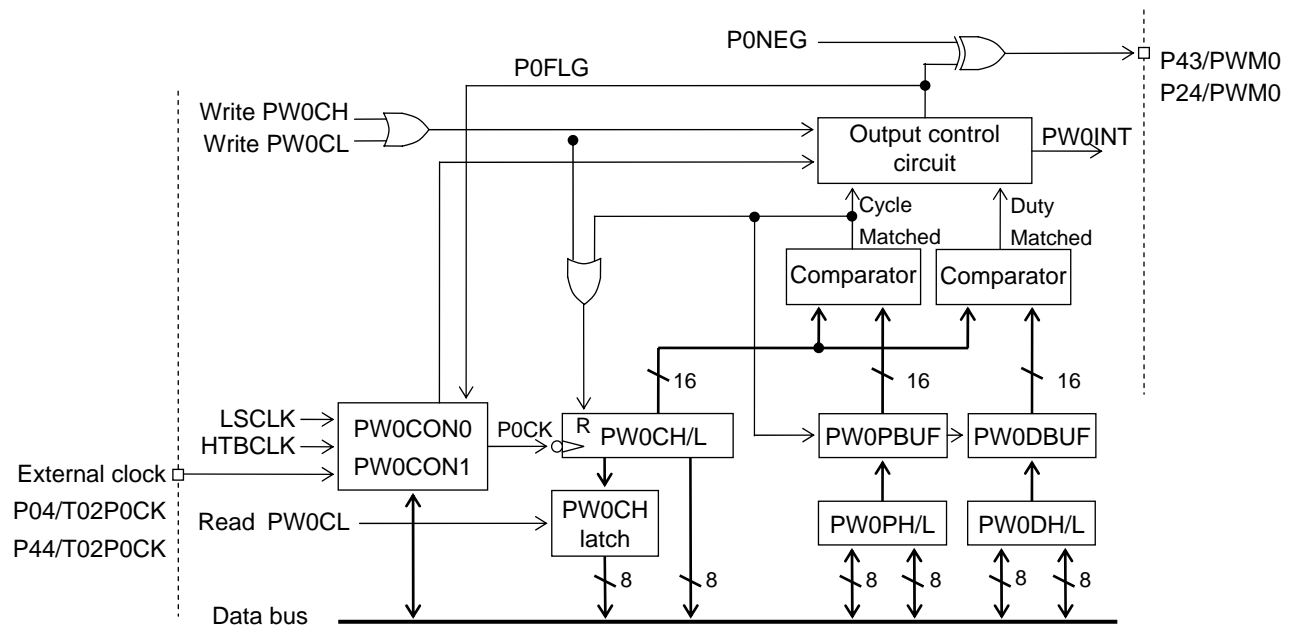

| | |
|---------|---------------------------|
| PW0PL | : PWM0 period register L |
| PW0PH | : PWM0 period register H |
| PW0PBUF | : PWM0 period buffer |
| PW0DL | : PWM0 duty register L |
| PW0DH | : PWM0 duty register H |
| PW0DBUF | : PWM0 duty buffer |
| PW0CL | : PWM0 counter register L |
| PW0CH | : PWM0 counter register H |
| PW0CON0 | : PWM0 control register 0 |
| PW0CON1 | : PWM0 control register 1 |

Figure 10-1 Configuration of PWM Circuit

10.1.3 List of Pins

| Pin name | Input/output | Function |
|-------------|--------------|--|
| P04/T02P0CK | I | PWM0 external clock input pin Used for the primary function of the P04 pin. |
| P44/T02P0CK | I | PWM0 external clock input pin Used for the primary function of the P44 pin. |
| P43/PWM0 | O | PWM0 output pin Used for the tertiary function of the P43 pin. |
| P24/PWM0 | O | PWM0 output pin Used as the secondary function of the P24 pin. |

10.2 Description of Registers

10.2.1 List of Registers

| Address | Name | Symbol (Byte) | Symbol (Word) | R/W | Size | Initial value |
|---------|-------------------------|---------------|---------------|-----|------|---------------|
| 0F0A0H | PWM0 period register L | PW0PL | PW0P | R/W | 8/16 | 0FFH |
| 0F0A1H | PWM0 period register H | PW0PH | | R/W | 8 | 0FFH |
| 0F0A2H | PWM0 duty register L | PW0DL | PW0D | R/W | 8/16 | 00H |
| 0F0A3H | PWM0 duty register H | PW0DH | | R/W | 8 | 00H |
| 0F0A4H | PWM0 counter register L | PW0CL | PW0C | R/W | 8/16 | 00H |
| 0F0A5H | PWM0 counter register H | PW0CH | | R/W | 8 | 00H |
| 0F0A6H | PWM0 control register 0 | PW0CON0 | PW0CON | R/W | 8/16 | 00H |
| 0F0A7H | PWM0 control register 1 | PW0CON1 | | R/W | 8 | 40H |

10.2.2 PWM0 Period Registers (PW0PL, PW0PH)

Address: 0F0A0H
 Access: R/W
 Access size: 8-bit
 Initial value: 0FFH

| | 7 | 6 | 5 | 4 | 3 | 2 | 1 | 0 |
|---------------|------|------|------|------|------|------|------|------|
| PW0PL | P0P7 | P0P6 | P0P5 | P0P4 | P0P3 | P0P2 | P0P1 | P0P0 |
| R/W | R/W | R/W | R/W | R/W | R/W | R/W | R/W | R/W |
| Initial value | 1 | 1 | 1 | 1 | 1 | 1 | 1 | 1 |

Address: 0F0A1H
 Access: R/W
 Access size: 8-bit
 Initial value: 0FFH

| | 7 | 6 | 5 | 4 | 3 | 2 | 1 | 0 |
|---------------|-------|-------|-------|-------|-------|-------|------|------|
| PW0PH | P0P15 | P0P14 | P0P13 | P0P12 | P0P11 | P0P10 | P0P9 | P0P8 |
| R/W | R/W | R/W | R/W | R/W | R/W | R/W | R/W | R/W |
| Initial value | 1 | 1 | 1 | 1 | 1 | 1 | 1 | 1 |

PW0PH and PW0PL are special function registers (SFRs) to set the PWM0 periods.

Note:

When PW0PH or PW0PL is set to "0000H", the PWM0 period buffer (PW0PBUF) is set to "0001H".

10.2.3 PWM0 Duty Registers (PW0DL, PW0DH)

| | 7 | 6 | 5 | 4 | 3 | 2 | 1 | 0 |
|---------------|------|------|------|------|------|------|------|------|
| PW0DL | P0D7 | P0D6 | P0D5 | P0D4 | P0D3 | P0D2 | P0D1 | P0D0 |
| R/W | R/W | R/W | R/W | R/W | R/W | R/W | R/W | R/W |
| Initial value | 0 | 0 | 0 | 0 | 0 | 0 | 0 | 0 |

Address: 0F0A2H
 Access: R/W
 Access size: 8-bit
 Initial value: 00H

| | 7 | 6 | 5 | 4 | 3 | 2 | 1 | 0 |
|---------------|-------|-------|-------|-------|-------|-------|------|------|
| PW0DH | P0D15 | P0D14 | P0D13 | P0D12 | P0D11 | P0D10 | P0D9 | P0D8 |
| R/W | R/W | R/W | R/W | R/W | R/W | R/W | R/W | R/W |
| Initial value | 0 | 0 | 0 | 0 | 0 | 0 | 0 | 0 |

Address: 0F0A3H
 Access: R/W
 Access size: 8-bit
 Initial value: 00H

PW0DH and PW0DL are special function registers (SFRs) to set the duties of PWM0.

Note:

For the PW0DH and PW0DL, set data smaller than for the PW0PH and PW0PL.

10.2.4 PWM0 Counter Registers (PW0CH, PW0CL)

| | | | | | | | | |
|---------------|------|------|------|------|------|------|------|------|
| | 7 | 6 | 5 | 4 | 3 | 2 | 1 | 0 |
| PW0CL | P0C7 | P0C6 | P0C5 | P0C4 | P0C3 | P0C2 | P0C1 | P0C0 |
| R/W | R/W | R/W | R/W | R/W | R/W | R/W | R/W | R/W |
| Initial value | 0 | 0 | 0 | 0 | 0 | 0 | 0 | 0 |

Address: 0F0A4H
 Access: R/W
 Access size: 8-bit
 Initial value: 00H

| | | | | | | | | |
|---------------|-------|-------|-------|-------|-------|-------|------|------|
| | 7 | 6 | 5 | 4 | 3 | 2 | 1 | 0 |
| PW0CH | P0C15 | P0C14 | P0C13 | P0C12 | P0C11 | P0C10 | P0C9 | P0C8 |
| R/W | R/W | R/W | R/W | R/W | R/W | R/W | R/W | R/W |
| Initial value | 0 | 0 | 0 | 0 | 0 | 0 | 0 | 0 |

Address: 0F0A5H
 Access: R/W
 Access size: 8-bit
 Initial value: 00H

PW0CL and PW0CH are special function registers (SFRs) that function as 16-bit binary counters. When data is written to either PW0CL or PW0CH, PW0CL and PW0CH is set to “0000H”. The data that is written is meaningless. When data is read from PW0CL, the value of PW0CH is latched. When reading PW0CH and PW0CL, use a word type instruction or pre-read PW0CL.

The contents of PW0CH and PW0CL during PWM operation cannot be read depending on the combination of the PWM clock and system clock.

Table 10-1 shows PW0CH and PW0CL read enable/disable for each combination of the PWM clock and system clock.

Table 10-1 PW0CH and PW0CL Read Enable/Disable during PWM0 Operation

| PWM clock P0CK | System clock SYSCLK | PW0CH and PW0CL read enable/disable |
|-------------------|------------------------|---|
| LSCLK | LSCLK | Read enabled. |
| LSCLK | HSCLK | Read enabled. However, to prevent the reading of undefined data during counting, read consecutively PW0CH or PW0CL twice until the last data coincides the previous data. |
| HTBCLK | LSCLK | Read disabled. |
| HTBCLK | HSCLK | Read enabled. |
| External clock | LSCLK | Read disabled. |
| | HSCLK | |

10.2.5 PWM0 Control Register 0 (PW0CON0)

| | | | | | | | | |
|---------------|-----|-----|-----|-------|-------|-------|-------|-------|
| | 7 | 6 | 5 | 4 | 3 | 2 | 1 | 0 |
| PW0CON0 | — | — | — | PONEG | POIS1 | POIS0 | P0CS1 | P0CS0 |
| R/W | R/W | R/W | R/W | R/W | R/W | R/W | R/W | R/W |
| Initial value | 0 | 0 | 0 | 0 | 0 | 0 | 0 | 0 |

Address: 0F0A6H

Access: R/W

Access size: 8-bit

Initial value: 00H

PW0CON0 is a special function register (SFR) to control PWM.

[Description of Bits]

- **P0CS1, P0CS0** (bits 1, 0)

The P0CS1 and P0CS0 bits are used to select the PWM0 operation clocks. LSCLK, HTBCLK, or the external clock (P44/T02P0CK) can be selected by these bits.

| P0CS1 | P0CS0 | Description |
|-------|-------|------------------------------|
| 0 | 0 | LSCLK (initial value) |
| 0 | 1 | HTBCLK |
| 1 | 0 | External clock (P04/T02P0CK) |
| 1 | 1 | External clock (P44/T02P0CK) |

- **POIS1, POIS0** (bits 3, 2)

The POIS1 and POIS0 bits are used to select the point at which the PWM0 interrupt occurs. “When the periods coincide”, “when the duties coincide”, or “when the periods and duties coincide” can be selected.

| POIS1 | POIS0 | Description |
|-------|-------|--|
| 0 | 0 | When the periods coincide. (Initial value) |
| 0 | 1 | When the duties coincide. |
| 1 | * | When the periods and duties coincide. |

- **PONEG** (bit 4)

The PONEG bit is used to select the output logic. When the positive logic is selected, the initial value of PWM0 output is “1”, and when the negative logic is selected, the initial value of PWM0 output is “0”.

| PONEG | Description |
|-------|--------------------------------|
| 0 | Positive logic (initial value) |
| 1 | Negative logic |

10.2.6 PWM0 Control Register 1 (PW0CON1)

| | | | | | | | | |
|---------------|--------|-------|-----|-----|-----|-----|-----|-------|
| | 7 | 6 | 5 | 4 | 3 | 2 | 1 | 0 |
| PW0CON1 | P0STAT | P0FLG | — | — | — | — | — | P0RUN |
| | R/W | R | R/W | R/W | R/W | R/W | R/W | R/W |
| Initial value | 0 | 1 | 0 | 0 | 0 | 0 | 0 | 0 |

Address: 0F0A7H
 Access: R/W
 Access size: 8-bit
 Initial value: 40H

PW0CON1 is a special function register (SFR) to control PWM0.

[Description of Bits]

- **P0RUN** (bit 0)
 The P0RUN bit is used to control count stop/start of PWM0.

| P0RUN | Description |
|-------|---------------------------------|
| 0 | Stops counting. (Initial value) |
| 1 | Starts counting. |

- **P0FLG** (bit 6)
 The P0FLG bit is used to read the output flag of PWM0.
 This bit is set to “1” when write operation to PW0CH or PW0CL is performed.

| P0FLG | Description |
|-------|--|
| 0 | PWM0 output flag = “0” |
| 1 | PWM0 output flag = “1” (initial value) |

- **P0STAT** (bit 7)
 The P0STAT bit indicates “counting stopped or “counting in progress” of PWM0.

| P0STAT | Description |
|--------|-----------------------------------|
| 0 | Counting stopped. (Initial value) |
| 1 | Counting in progress. |

10.3 Description of Operation

The PWM0 counter registers (PW0CH, PW0CL) are set to an operating state (P0STAT is set to "1") on the first falling edge of the PWM clock (P0CK) that are selected by the PWM0 control register 0 (PW0CON0) when the PORUN bit of PWM0 control register 1 (PW0CON1) is set to "1" and increment the count value on the 2nd falling edge.

When the count value of PWM0 counter registers and the value of the PWM0 duty buffer (PW0DBUF) coincide, the PWM flag (P0FLG) is set to "0" on the next timer clock falling edge of P0CK.

When the PW0CH and PW0CL count values match the PWM0 period buffer value, the P0FLG becomes "1" at the next P0CK falling edge and the PW0CH and PW0CL are reset to 0000H to continue incremental counting. At the same time, the value of the PWM0 duty register (PW0DH, PW0DL) is transferred to the PWM0 duty buffer (PW0DBUF) and the value of PWM0 period register (PW0PH, PW0PL) to the PWM0 period buffer (PW0PBUF).

When the PORUN bit is set to "0", PWM0 counter registers stop counting after counting once the falling of the PWM clock (P0CK). Confirm that PW0CH and PW0CL are stopped by checking that the PnSTAT bit of the PWM0 control register 1 (PW0CON1) is "0". When the PORUN bit is set to "1" again, PWM0 counter registers restarts incremental counting from the previous value on the falling edge of P0CK.

To initialize PWM0 counter registers to "0000H", perform write operation in either of PW0CH or PW0CL. At that time, P0FLG is also set to "1".

When data is written in the PWM0 duty register (PW0DH, PW0DL) during count stop (PORUN is in a "1" state), the data is transferred to the PWM0 duty buffer (PW0DBUF) and when data is written in the PWM0 period register (PW0PH, PW0PL), the data is transferred to the PWM0 period buffer (PW0PBUF).

The PWM clock, the point at which an interrupt of PWM0 occurs, and the logic of the PWM output are selected by PWM0 control register 0 (PW0CN0).

The period of the PWM0 signal (T_{PWP}) and the first half duration (T_{PWD}) of the duty are expressed by the following equations.

$$T_{PWP} = \frac{PW0P + 1}{P0CK \text{ (Hz)}}$$

$$T_{PWD} = \frac{PW0D + 1}{P0CK \text{ (Hz)}}$$

PW0P: PWM0 period registers (PW0PH, PW0PL) setting value (0001H to 0FFFFH)

PW0D: PWM0 duty registers (PW0DH, PW0DL) setting value (0000H to 0FFFEH)

P0CK: Clock frequency selected by the PWM0 control register 0 (PW0CON0)

After the P0RUN bit is set to "1", counting starts in synchronization with the PWM clock. This causes an error of up to 1 clock pulse to the time the first PWM interrupt is issued. The PWM interrupt period from the second time is fixed. Figure 10-2 shows the operation timing of PWM0.

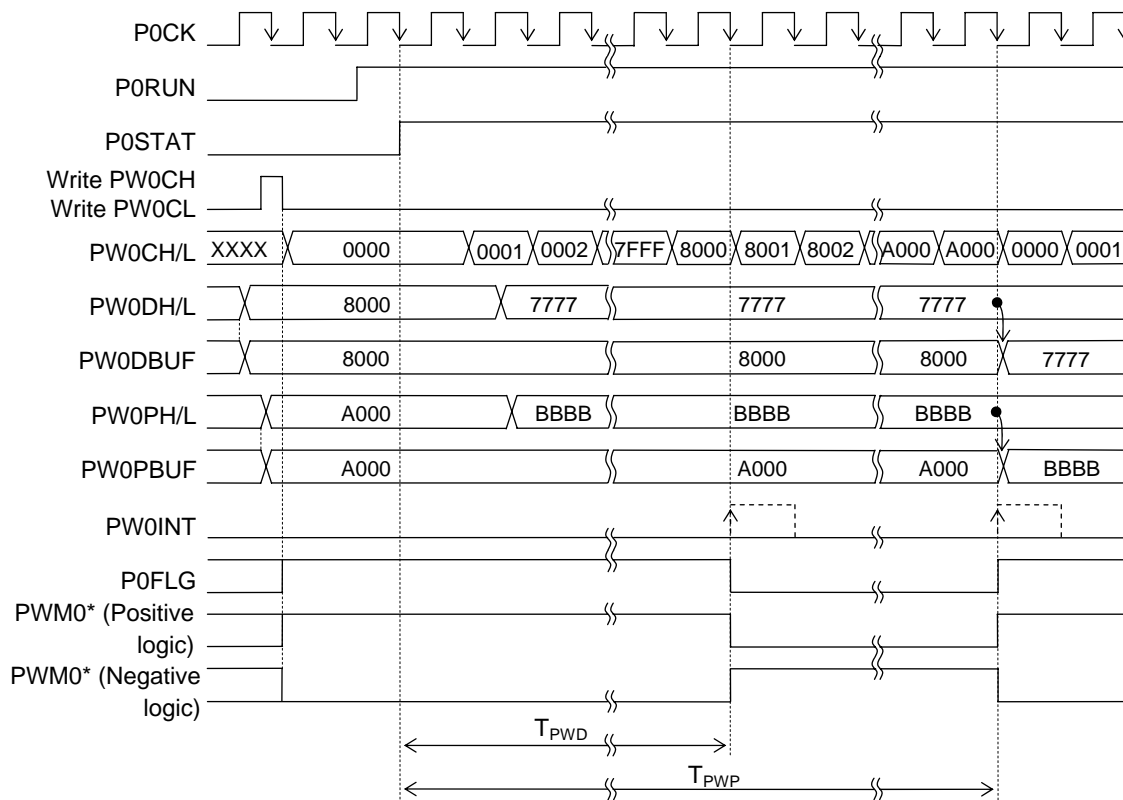

Figure 10-2 (1/2) Operation Timing Diagram of PWM0

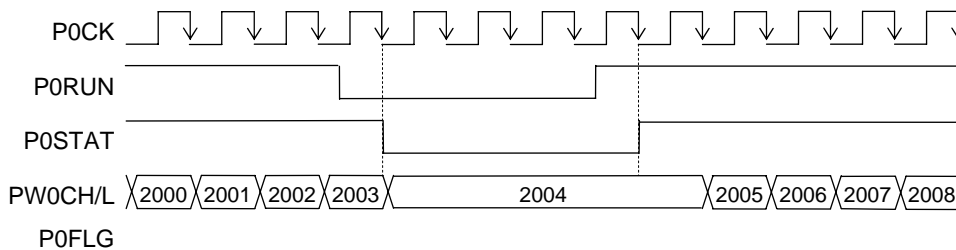

Figure 10-2 (2/2) Operation Timing Diagram of PWM0

Note:

Even if "0" is written to the P0RUN bit, counting operation continues up to the falling edge (the PWM0 status flag (P0STAT) is in a "1" state) of the next PWM clock pulse. Therefore, the PWM0 interrupt (PW0INT) may occur.

10.4 Specifying port registers

To output the PWM waveform, the applicable bit of each related port register needs to be set. See Chapter 17, "Port 4" and Chapter 15, "Port 2" for detail about the port registers.

10.4.1 Functioning the P43 pin (PWM0) as the PWM output

Set P43MD1 bit (bit3 of P4MOD1 register) to "1" and set P43MD0 bit (bit3 of P4MOD0 register) to "0", for specifying the PWM output as the tertiary function of P43.

| Register name | P4MOD1 register (Address: 0F225H) | | | | | | | |
|---------------|-----------------------------------|--------|--------|--------|---------------|--------|--------|--------|
| Bit | 7 | 6 | 5 | 4 | 3 | 2 | 1 | 0 |
| Bit name | P47MD1 | P46MD1 | P45MD1 | P44MD1 | P43MD1 | P42MD1 | P41MD1 | P40MD1 |
| Setting value | * | * | * | * | 1 | * | * | * |

| Register name | P4MOD0 register (Address: 0F224H) | | | | | | | |
|---------------|-----------------------------------|--------|--------|--------|---------------|--------|--------|--------|
| Bit | 7 | 6 | 5 | 4 | 3 | 2 | 1 | 0 |
| Bit name | P47MD0 | P46MD0 | P45MD0 | P44MD0 | P43MD0 | P42MD0 | P41MD0 | P40MD0 |
| Setting value | * | * | * | * | 0 | * | * | * |

Set the P43C1 bit (P4CON1 register bit 3) to "1", the P43C0 bit (P4CON0 register bit 3) to "1", and the P43DIR bit (P4DIR register bit 3) to "0" for selecting the state mode of the P43 pin used for the PWM to CMOS output.

| Register name | P4CON1 register (Address: 0F223H) | | | | | | | |
|---------------|-----------------------------------|-------|-------|-------|--------------|-------|-------|-------|
| Bit | 7 | 6 | 5 | 4 | 3 | 2 | 1 | 0 |
| Bit name | P47C1 | P46C1 | P45C1 | P44C1 | P43C1 | P42C1 | P41C1 | P40C1 |
| Setting value | * | * | * | * | 1 | * | * | * |

| Register name | P4CON0 register (Address: 0F222H) | | | | | | | |
|---------------|-----------------------------------|-------|-------|-------|--------------|-------|-------|-------|
| Bit | 7 | 6 | 5 | 4 | 3 | 2 | 1 | 0 |
| Bit name | P47C0 | P46C0 | P45C0 | P44C0 | P43C0 | P42C0 | P41C0 | P40C0 |
| Setting value | * | * | * | * | 1 | * | * | * |

| Register name | P4DIR register (Address: 0F221H) | | | | | | | |
|---------------|----------------------------------|--------|--------|--------|---------------|--------|--------|--------|
| Bit | 7 | 6 | 5 | 4 | 3 | 2 | 1 | 0 |
| Bit name | P47DIR | P46DIR | P45DIR | P44DIR | P43DIR | P42DIR | P41DIR | P40DIR |
| Setting value | * | * | * | * | 0 | * | * | * |

The P43D bit (P4D register bit 3) data can either be "0" or "1".

| Register name | P4D register (Address: 0F220H) | | | | | | | |
|---------------|--------------------------------|------|------|------|-------------|------|------|------|
| Bit | 7 | 6 | 5 | 4 | 3 | 2 | 1 | 0 |
| Bit name | P47D | P46D | P45D | P44D | P43D | P42D | P41D | P40D |
| Setting value | * | * | * | * | ** | * | * | * |

* : Bit not related to the PWM function

** : Don't care

10.4.2 Functioning the P24 pin (PWM0) as the PWM output

Set the P24MD bit (P2MOD register bit 4) to "1" for specifying the PWM as the secondary function of the P24.

| Register name | P2MOD register (Address: 0F214H) | | | | | | | |
|---------------|----------------------------------|---|---|--------------|---|-------|-------|-------|
| Bit | 7 | 6 | 5 | 4 | 3 | 2 | 1 | 0 |
| Bit name | - | - | - | P24MD | - | P22MD | P21MD | P20MD |
| Setting value | - | - | - | 1 | * | * | * | * |

Set the P24C1 bit (P2CON1 register's bit 4) to "1" and the P24C0 bit (P2CON0 register's bit 4) to "1" for specifying the state mode of the P24 pin used for the PWM to CMOS output.

| Register name | P2CON1 register (Address: 0F213H) | | | | | | | |
|---------------|-----------------------------------|---|---|--------------|---|-------|-------|-------|
| Bit | 7 | 6 | 5 | 4 | 3 | 2 | 1 | 0 |
| Bit name | - | - | - | P24C1 | - | P22C1 | P21C1 | P20C1 |
| Setting value | - | - | - | 1 | * | * | * | * |

| Register name | P2CON0 register (Address: 0F212H) | | | | | | | |
|---------------|-----------------------------------|---|---|--------------|---|-------|-------|-------|
| Bit | 7 | 6 | 5 | 4 | 3 | 2 | 1 | 0 |
| Bit name | - | - | - | P24C0 | - | P22C0 | P21C0 | P20C0 |
| Setting value | - | - | - | 1 | * | * | * | * |

The P24D bit (P2D register bit 4) data can either be "0" or "1".

| Register name | P2D register (Address: 0F210H) | | | | | | | |
|---------------|--------------------------------|---|---|-------------|---|------|------|------|
| Bit | 7 | 6 | 5 | 4 | 3 | 2 | 1 | 0 |
| Bit name | - | - | - | P24D | - | P22D | P21D | P20D |
| Setting value | - | - | - | ** | * | * | * | * |

- : Bit that does not exist
- * : Bit not related to the PWM function
- ** : Don't care

10.4.3 Operating PWM0 with External Clock (P04/T02P0CK)

Set the P04E0 bit (EXICON0 register's bit 4) to "0" and the P04E1 bit (EXICON1 register's bit 4) to "0" for specifying the P04 external interrupt to Disable.

| Register name | EXICON0 register (address: 0F020H) | | | | | | | |
|---------------|------------------------------------|---|---|--------------|-------|-------|-------|-------|
| Bit | 7 | 6 | 5 | 4 | 3 | 2 | 1 | 0 |
| Bit name | - | - | - | P04E0 | P03E0 | P02E0 | P01E0 | P00E0 |
| Setting value | * | * | * | 0 | * | * | * | * |

| Register name | EXICON1 register (address: 0F021H) | | | | | | | |
|---------------|------------------------------------|---|---|--------------|-------|-------|-------|-------|
| Bit | 7 | 6 | 5 | 4 | 3 | 2 | 1 | 0 |
| Bit name | - | - | - | P04E1 | P03E1 | P02E1 | P01E1 | P00E1 |
| Setting value | * | * | * | 0 | * | * | * | * |

Set the P04C0 bit (P0CON0 register's bit 4) to "0" and the P04C1 bit (P0CON1 register's bit 4) to "0" for specifying the state mode of the P04 pin to high-impedance input.

| Register name | P0CON0 register (Address: 0F206H) | | | | | | | |
|---------------|-----------------------------------|---|---|--------------|-------|-------|-------|-------|
| Bit | 7 | 6 | 5 | 4 | 3 | 2 | 1 | 0 |
| Bit name | - | - | - | P04C0 | P03C0 | P02C0 | P01C0 | P00C0 |
| Setting value | * | * | * | 0 | * | * | * | * |

| Register name | P0CON1 register (Address: 0F207H) | | | | | | | |
|---------------|-----------------------------------|---|---|--------------|-------|-------|-------|-------|
| Bit | 7 | 6 | 5 | 4 | 3 | 2 | 1 | 0 |
| Bit name | - | - | - | P04C1 | P03C1 | P02C1 | P01C1 | P00C1 |
| Setting value | * | * | * | 0 | * | * | * | * |

Set the P0CS1 bit (PW0CON0 register's bit 1) to "1" and the P0CS0 bit (PW0CON0 register's bit 0) to "0".

| Register name | PW0CON0 register (address: 0F0A6H) | | | | | | | |
|---------------|------------------------------------|---|---|-------|-------|-------|--------------|--------------|
| Bit | 7 | 6 | 5 | 4 | 3 | 2 | 1 | 0 |
| Bit name | — | — | — | P0NEG | POIS1 | P0IS0 | P0CS1 | P0CS0 |
| Setting value | * | * | * | * | * | * | 1 | 0 |

Input the operation clock for the PWM0 from the P04 pin.

10.4.4 Operating PWM0 with External Clock (P44/T02P0CK)

Set the P44MD1 bit (P4MOD1 register's bit 4) to "0" and the P44MD0 bit (P4MOD0 register's bit 4) to "0" for specifying the P44 to the primary function.

| Register name | P4MOD1 register (Address: 0F225H) | | | | | | | |
|---------------|-----------------------------------|--------|--------|---------------|--------|--------|--------|--------|
| Bit | 7 | 6 | 5 | 4 | 3 | 2 | 1 | 0 |
| Bit name | P47MD1 | P46MD1 | P45MD1 | P44MD1 | P43MD1 | P42MD1 | P41MD1 | P40MD1 |
| Setting value | * | * | * | 0 | * | * | * | * |

| Register name | P4MOD0 register (Address: 0F224H) | | | | | | | |
|---------------|-----------------------------------|--------|--------|---------------|--------|--------|--------|--------|
| Bit | 7 | 6 | 5 | 4 | 3 | 2 | 1 | 0 |
| Bit name | P47MD0 | P46MD0 | P45MD0 | P44MD0 | P43MD0 | P42MD0 | P41MD0 | P40MD0 |
| Setting value | * | * | * | 0 | * | * | * | * |

Set the P44C1 bit (P4CON1 register's bit 4) to "0", the P44C0 bit (P4CON0 register's bit 4) to "0", and the P43DIR bit (P4DIR register's bit 3) to "1" for specifying the state mode of the P44 pin to high-impedance input.

| Register name | P4CON1 register (Address: 0F223H) | | | | | | | |
|---------------|-----------------------------------|-------|-------|--------------|-------|-------|-------|-------|
| Bit | 7 | 6 | 5 | 4 | 3 | 2 | 1 | 0 |
| Bit name | P47C1 | P46C1 | P45C1 | P44C1 | P43C1 | P42C1 | P41C1 | P40C1 |
| Setting value | * | * | * | 0 | * | * | * | * |

| Register name | P4CON0 register (Address: 0F222H) | | | | | | | |
|---------------|-----------------------------------|-------|-------|--------------|-------|-------|-------|-------|
| Bit | 7 | 6 | 5 | 4 | 3 | 2 | 1 | 0 |
| Bit name | P47C0 | P46C0 | P45C0 | P44C0 | P43C0 | P42C0 | P41C0 | P40C0 |
| Setting value | * | * | * | 0 | * | * | * | * |

| Register name | P4DIR register (Address: 0F221H) | | | | | | | |
|---------------|----------------------------------|--------|--------|---------------|--------|--------|--------|--------|
| Bit | 7 | 6 | 5 | 4 | 3 | 2 | 1 | 0 |
| Bit name | P47DIR | P46DIR | P45DIR | P44DIR | P43DIR | P42DIR | P41DIR | P40DIR |
| Setting value | * | * | * | 1 | * | * | * | * |

Set the P0CS1 bit (PW0CON0 register's bit 1) to "1" and the P0CS0 bit (PW0CON0 register's bit 0) to "1".

| Register name | PW0CON0 register (address: 0F0A6H) | | | | | | | |
|---------------|------------------------------------|---|---|-------|-------|-------|--------------|--------------|
| Bit | 7 | 6 | 5 | 4 | 3 | 2 | 1 | 0 |
| Bit name | — | — | — | P0NEG | POIS1 | P0IS0 | P0CS1 | P0CS0 |
| Setting value | * | * | * | * | * | * | 1 | 1 |

Input the operation clock for the PWM0 from the P44 pin.

Watchdog Timer

11. Watchdog Timer

11.1 Overview

This LSI incorporates a watchdog timer (WDT) that operates at a system reset unconditionally (free-run operation) in order to detect an undefined state of the MCU and return from that state. If the WDT counter overflows due to the failure of clearing of the WDT counter within the WDT overflow period, the watchdog timer requests a WDT interrupt (non-maskable interrupt). When the second overflow occurs, the watchdog timer generates a WDT reset signal and shifts the mode to a system reset mode. For interrupts see Chapter 5, "Interrupt," and for WDT interrupt see Chapter 3, "Reset Function".

11.1.1 Features

- Non-maskable interrupt
- Free running (cannot be stopped)
- One of four types of overflow periods (125ms, 500ms, 2s, and 8s) selectable by software
- Reset generated by the second overflow

11.1.2 Configuration

Figure 11-1 shows the configuration of the watchdog timer.

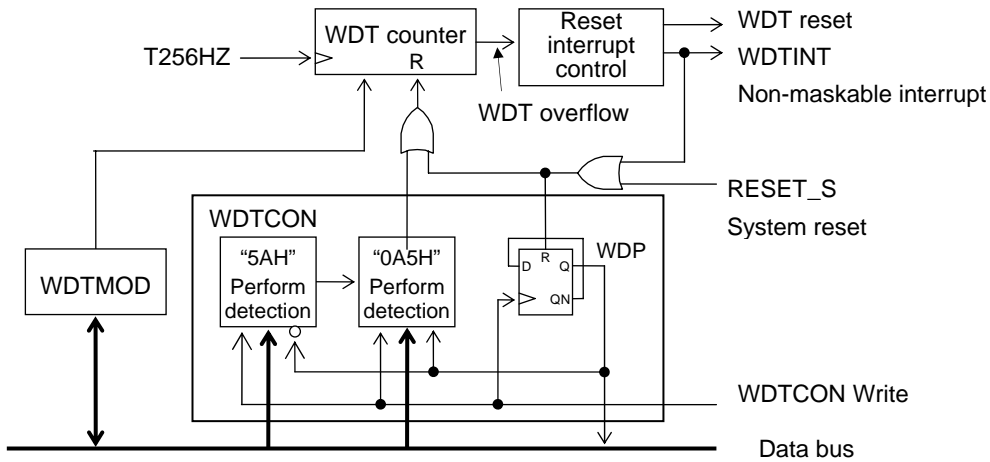

WDTCON : Watchdog timer control register
 WDTMOD : Watchdog timer mode register

Figure 11-1 Configuration of Watchdog Timer

11.2 Description of Registers

11.2.1 List of Registers

| Address | Name | Symbol (Byte) | Symbol (Word) | R/W | Size | Initial value |
|---------|---------------------------------|---------------|---------------|-----|------|---------------|
| 0F00EH | Watchdog timer control register | WDTCON | — | R/W | 8 | 00H |
| 0F00FH | Watchdog timer mode register | WDTMOD | — | R/W | 8 | 02H |

11.2.2 Watchdog Timer Control Register (WDTCON)

Address: 0F00EH
 Access: W
 Access size: 8-bit
 Initial value: 00H

| | 7 | 6 | 5 | 4 | 3 | 2 | 1 | 0 |
|---------------|-----|-----|-----|-----|-----|-----|-----|--------|
| WDTCON | d7 | d6 | d5 | d4 | d3 | d2 | d1 | WDP/d0 |
| R/W | R/W | R/W | R/W | R/W | R/W | R/W | R/W | R/W |
| Initial value | 0 | 0 | 0 | 0 | 0 | 0 | 0 | 0 |

WDTCON is a special function register (SFR) to clear the WDT counter.
 When WDTCON is read, the value of the internal pointer (WDP) is read from bit 0.

[Description of Bits]

- **WDP/d0** (bit 0)
 The value of the internal pointer (WDP) is read from this bit. The WDP is reset to "0" at the system reset or WDT counter overflow and is inverted every writing to WDTCON.
- **d7-d0** (bits 7-0)
 This bit is used to write data to clear the WDT counter. The WDT counter can be cleared by writing "5AH" with the internal pointer (WDP) is "0", then writing "0A5H" with the WDP "1".

Note:

When the WDT interrupt (WDTINT) occurs by the first WDT counter overflow, the counter and the internal pointer (WDP) are initialized for a half cycle of low speed clock (about 15us). During the time period that they are initialized, writing to WDTCON is disabled and the logic of WDP does not change. Therefore, in the case of that you have program codes handle to clear the WDT when the first overflow WDT interrupt occurs and also the codes run at high-speed system clock, please check the WDP gets reversed after writing to WDTCON to see if the writing was surely successful. For example of the program code, see Section 11.3.1, "Handling example when you do not want to use the watch dog timer".

11.2.3 Watchdog Timer Mode Register (WDTMOD)

Address: 0F00FH
 Access: W
 Access size: 8-bit
 Initial value: 02H

| | | | | | | | | |
|---------------|-----|-----|-----|-----|-----|-----|------|------|
| | 7 | 6 | 5 | 4 | 3 | 2 | 1 | 0 |
| WDTMOD | — | — | — | — | — | — | WDT1 | WDT0 |
| R/W | R/W | R/W | R/W | R/W | R/W | R/W | R/W | R/W |
| Initial value | 0 | 0 | 0 | 0 | 0 | 0 | 1 | 0 |

WDTMOD is a special function register to set the overflow period of the WDT counter.

[Description of Bits]

- **WDT1-0** (bits 1-0)

These bits are used to select an overflow period of the watchdog timer.

The WDT1 and WDT0 bits set an overflow period (T_{WOV}) of the WDT counter. One of 125ms, 500ms, 2s, and 8s can be selected.

| WDT1 | WDT0 | Description |
|------|------|--------------------|
| 0 | 0 | 125ms |
| 0 | 1 | 500ms |
| 1 | 0 | 2s (initial value) |
| 1 | 1 | 8s |

11.3 Description of Operation

The WDT counter starts counting after the system reset has been released and the low-speed clock oscillation start.. The WDT counter can be cleared by writing "5AH" with the internal pointer (WDP) is "0", then writing "0A5H" with the WDP "1".

The WDP is reset to "0" at the system reset or WDT counter overflow and is inverted every writing to WDTCON. When the WDT counter cannot be cleared within the WDT counter overflow period (T_{WOV}), a watchdog timer interrupt (WDTINT) occurs. If the WDT counter is not cleared even by the software processing performed following the watchdog timer interrupt and overflow occurs again, WDT reset occurs and the mode shifts to a system reset mode. For the overflow period (T_{WOV}) of the WDT counter, one of 125ms, 500ms, 2s, and 8s can be selected by the watchdog mode register (WDTMOD).

Clear the WDT counter within the clear period of the WDT counter (T_{WCL}) shown in Table 11-1.

Table 11-1 Clear Period of WDT Counter

| WDT1 | WDT0 | T_{WOV} | T_{WCL} |
|------|------|-----------|-----------------|
| 0 | 0 | 125ms | Approx. 121ms |
| 0 | 1 | 500ms | Approx. 496 ms |
| 1 | 0 | 2000ms | Approx. 1996 ms |
| 1 | 1 | 8000ms | Approx. 7996 ms |

Figure 11-2 shows an example of watchdog timer operation.

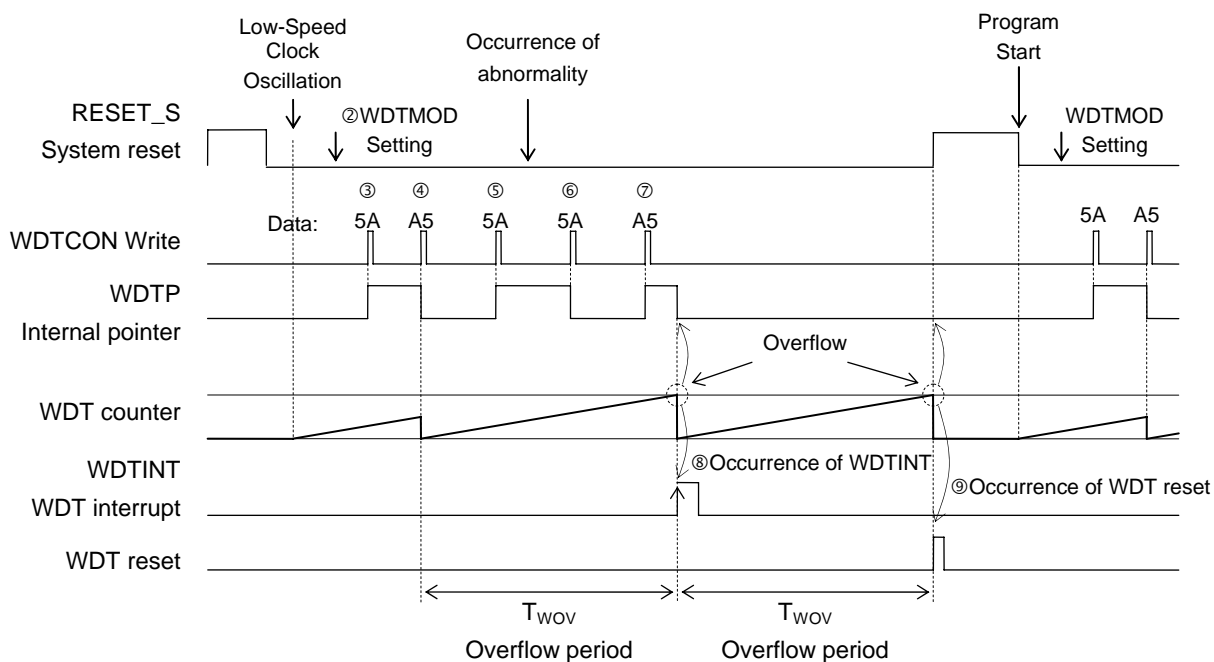

Figure 11-2 Example of Watchdog Timer Operation

- ① The WDT counter starts counting after the system reset has been released and the low-speed clock oscillation start.
- ② The overflow period of the WDT counter (T_{wov}) is set to WDTMOD.
- ③ “5AH” is written to WDTCON. (Internal pointer 0 to 1)
- ④ “0A5H” is written to WDTCON and the WDT counter is cleared. (Internal pointer 1 to 0)
- ⑤ “5AH” is written to WDTCON. (Internal pointer 0 to 1)
- ⑥ When “5AH” is written to WDTCON after the occurrence of abnormality, it cannot be accepted as the internal pointer is set to “1”. (Internal pointer 1 to 0)
- ⑦ Although “0A5H” is written to WDTCON, the WDT counter is not cleared since the internal pointer is “0” and the writing of “5AH” is not accepted in ⑥. (Internal pointer 0 to 1)
- ⑧ The WDT counter overflows and a watchdog timer interrupt request (WDTINT) is generated. In this case, the WDT counter and the internal pointer (WDP) are initialized for a half cycle of low speed clock (about 15.26 μ s).
- ⑨ If the WDT counter is not cleared even by the software processing performed following a watchdog timer interrupt and the WDT counter overflows again, WDT reset occurs and the mode is shifted to a system reset mode.

Note:

- In STOP mode, the watchdog timer operation also stops.
- In HALT mode, the watchdog timer operation does not stop. When the WDT interrupt occurs, the HALT mode is released.
- The watchdog timer cannot detect all the abnormal operations. Even if the CPU loses control, the watchdog timer cannot detect the abnormality in the operation state in which the WDT counter is cleared.

11.3.1 Handling example when you do not want to use the watch dog timer

WDT counter is a free-run counter that starts count-up automatically after the system reset released and the low-speed clock (LSCLK) starts oscillating. If the WDT counter gets overflow, the WDT non-maskable interrupt occurs and then a system reset occurs. Therefore, it is needed to clear the WDT counter even if you do not want to use the WDT as a fail-safe function.

See following example programming codes to clear the WDT counter in the interrupt routine.

Example programming code:

```
__DI();                // Disable multi-interrupts
do
{
    WDTCON = 0x5a;
} while(WDP != 1)
WDTCON = 0xa5;
__EI();
```

Synchronous Serial Port

12 Synchronous Serial Port

12.1 Overview

This LSI includes two channels of 8/16-bit synchronous serial ports (SSIO). It can also be used to control the device incorporated with the SPI interface by using one GPIO as the chip enable pin.

When the synchronous serial port is used, the tertiary functions of Port 4 or the tertiary functions of Port 5 must be set. For the tertiary function setting of Port 4, see Chapter 17, "Port 4." For the tertiary function setting of Port 5, see Chapter 18, "Port 5."

12.1.1 Features

- Master or slave selectable
- MSB first or LSB first selectable
- 8-bit length or 16-bit length selectable fro the data length

12.1.2 Configuration

Figure 12-1 shows the configuration of the synchronous serial port.

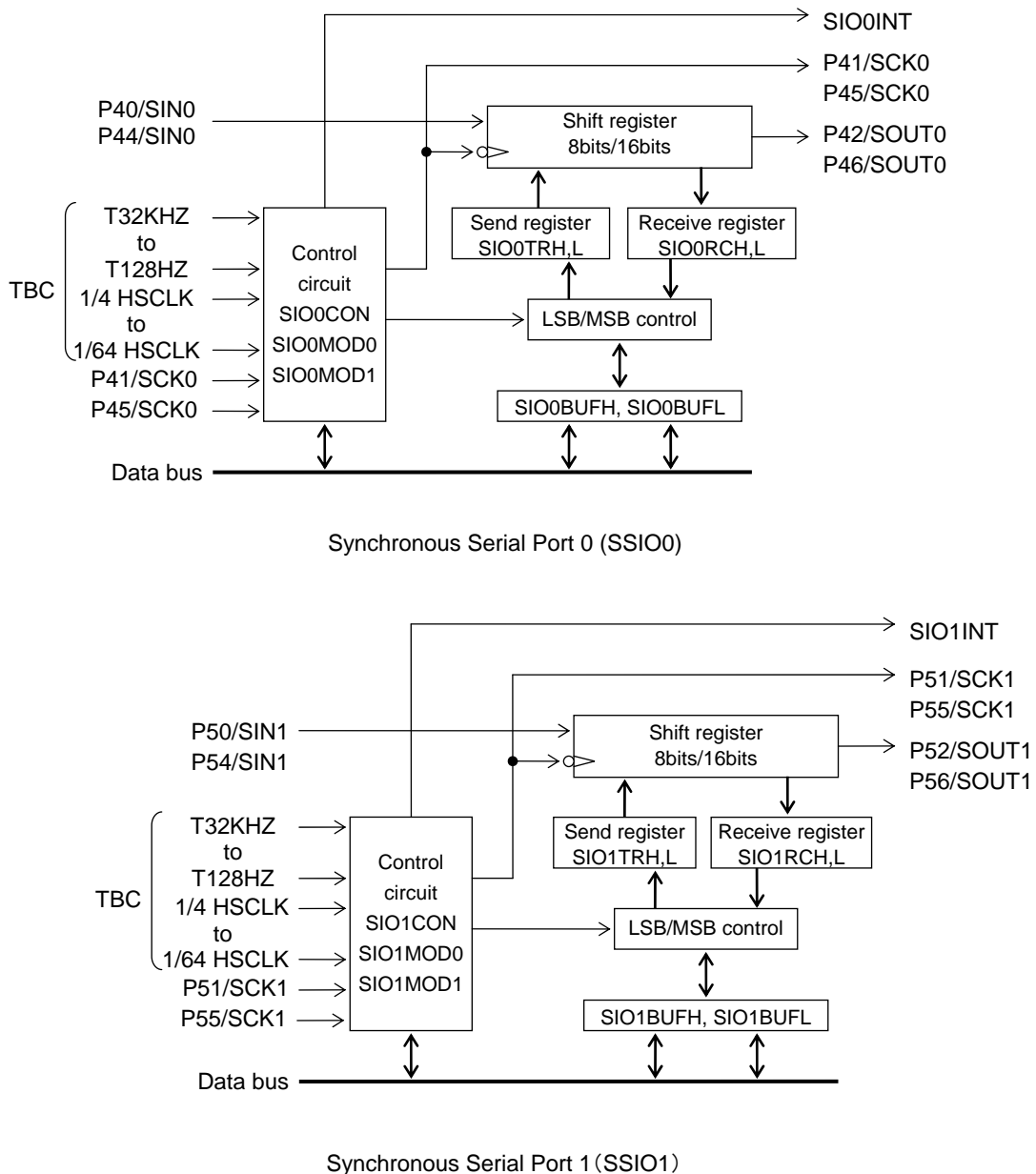

SIO0BUFL, SIO1BUFL : Serial port transmit/receive buffer L
 SIO0BUFH, SIO1BUFH : Serial port transmit/receive buffer H
 SIO0CON, SIO1CON : Serial port control register
 SIO0MOD0, SIO1MOD0: Serial port mode register 0
 SIO0MOD1, SIO1MOD1: Serial port mode register 1

Figure 12-1 Configuration of Synchronous Serial Port

12.1.3 List of Pins

| Pin name | I/O | Function |
|------------------------|-----|--|
| P40/SIN0 P44/SIN0 | I | Received data input. Used for the tertiary function of the P40 and P44 pins. |
| P41/SCK0 P45/SCK0 | I/O | Synchronous clock input/output. Used for the tertiary function of the P41 and P45 pins. |
| P42/SOUT0 P46/SOUT0 | O | Transmitted data output. Used for the tertiary function of the P42 and P46 pins. |
| P50/SIN1 P54/SIN1 | I | Received data input. Used for the secondary function of the P50 pin and P54 pin. |
| P51/SCK1 P55/SCK1 | I/O | Synchronous clock input/output. Used for the secondary function of the P51 pin and P55 pin. |
| P52/SOUT1 P56/SOUT1 | O | Transmitted data output. Used for the secondary function of the P52 pin and P56 pin. |

12.2 Description of Registers

12.2.1 List of Registers

| Address | Name | Symbol (Byte) | Symbol (Word) | R/W | Size | Initial value |
|---------|---|---------------|---------------|-----|------|---------------|
| 0F280H | Serial port 0 transmit/receive buffer L | SIO0BUFL | SIO0BUF | R/W | 8/16 | 00H |
| 0F281H | Serial port 0 transmit/receive buffer H | SIO0BUFH | | R/W | 8 | 00H |
| 0F282H | Serial port 0 control register | SIO0CON | — | R/W | 8 | 00H |
| 0F284H | Serial port 0 mode register 0 | SIO0MOD0 | SIO0MOD | R/W | 8/16 | 00H |
| 0F285H | Serial port 0 mode register 1 | SIO0MOD1 | | R/W | 8 | 00H |
| 0F288H | Serial port 1 transmit/receive buffer L | SIO1BUFL | SIO1BUF | R/W | 8/16 | 00H |
| 0F289H | Serial port 1 transmit/receive buffer H | SIO1BUFH | | R/W | 8 | 00H |
| 0F28AH | Serial port 1 control register | SIO1CON | — | R/W | 8 | 00H |
| 0F28CH | Serial port 1 mode register 0 | SIO1MOD0 | SIO1MOD | R/W | 8/16 | 00H |
| 0F28DH | Serial port 1 mode register 1 | SIO1MOD1 | | R/W | 8 | 00H |

12.2.2 Serial Port 0 Transmit/Receive Buffers (SIO0BUFL and SIO0BUFH)

Address: 0F280H
 Access: R/W
 Access size: 8 bits/16 bits
 Initial value: 00H

| | 7 | 6 | 5 | 4 | 3 | 2 | 1 | 0 |
|---------------|------|------|------|------|------|------|------|------|
| SIO0BUFL | S0B7 | S0B6 | S0B5 | S0B4 | S0B3 | S0B2 | S0B1 | S0B0 |
| R/W | R/W | R/W | R/W | R/W | R/W | R/W | R/W | R/W |
| Initial value | 0 | 0 | 0 | 0 | 0 | 0 | 0 | 0 |

Address: 0F281H
 Access: R/W
 Access size: 8-bit
 Initial value: 00H

| | 7 | 6 | 5 | 4 | 3 | 2 | 1 | 0 |
|---------------|-------|-------|-------|-------|-------|-------|------|------|
| SIO0BUFH | S0B15 | S0B14 | S0B13 | S0B12 | S0B11 | S0B10 | S0B9 | S0B8 |
| R/W | R/W | R/W | R/W | R/W | R/W | R/W | R/W | R/W |
| Initial value | 0 | 0 | 0 | 0 | 0 | 0 | 0 | 0 |

SIO0BUFL and SIO0BUFH are special function registers (SFRs) to write transmitted data and to read received data of the synchronous serial port 0.

When data is written in SIO0BUFL and SIO0BUFH, the data is written in the transmit registers (SIO0TRL and SIO0TRH). When data is read from SIO0BUFL and SIO0BUFH, the contents of the receive registers (SIO0RCL and SIO0RCH) are read.

12.2.3 Serial Port 1 Transmit/Receive Buffers (SIO1BUFL and SIO1BUFH)

Address: 0F288H
 Access: R/W
 Access size: 8 bits/16 bits
 Initial value: 00H

| | 7 | 6 | 5 | 4 | 3 | 2 | 1 | 0 |
|---------------|------|------|------|------|------|------|------|------|
| SIO1BUFL | S1B7 | S1B6 | S1B5 | S1B4 | S1B3 | S1B2 | S1B1 | S1B0 |
| R/W | R/W | R/W | R/W | R/W | R/W | R/W | R/W | R/W |
| Initial value | 0 | 0 | 0 | 0 | 0 | 0 | 0 | 0 |

Address: 0F289H
 Access: R/W
 Access size: 8-bit
 Initial value: 00H

| | 7 | 6 | 5 | 4 | 3 | 2 | 1 | 0 |
|---------------|-------|-------|-------|-------|-------|-------|------|------|
| SIO1BUFH | S1B15 | S1B14 | S1B13 | S1B12 | S1B11 | S1B10 | S1B9 | S1B8 |
| R/W | R/W | R/W | R/W | R/W | R/W | R/W | R/W | R/W |
| Initial value | 0 | 0 | 0 | 0 | 0 | 0 | 0 | 0 |

SIO1BUFL and SIO1BUFH are special function registers (SFRs) to write transmitted data and to read received data of the synchronous serial port 1.

When data is written in SIO1BUFL and SIO1BUFH, the data is written in the transmit registers (SIO1TRL and SIO1TRH). When data is read from SIO1BUFL and SIO1BUFH, the contents of the receive registers (SIO1RCL and SIO1RCH) are read.

12.2.4 Serial Port 0 Control Register (SIO0CON)

Address: 0F282H
 Access: R/W
 Access size: 8-bit
 Initial value: 00H

| | | | | | | | | |
|---------------|-----|-----|-----|-----|-----|-----|-----|------|
| | 7 | 6 | 5 | 4 | 3 | 2 | 1 | 0 |
| SIO0CON | — | — | — | — | — | — | — | S0EN |
| R/W | R/W | R/W | R/W | R/W | R/W | R/W | R/W | R/W |
| Initial value | 0 | 0 | 0 | 0 | 0 | 0 | 0 | 0 |

SIO0CON is a special function register (SFR) to control the synchronous serial port 0.

[Description of Bits]

- **S0EN** (bit 0)

The S0EN bit is used to specify start of synchronous serial communication. Writing a “1” to S0EN starts 8-/16-bit data communication. The S0EN bit is set to “0” automatically when 8-/16-bit data communication is terminated.

The S0EN bit is set to “0” at a system reset.

| S0EN | Description |
|------|--------------------------------------|
| 0 | Stops communication. (Initial value) |
| 1 | Starts communication |

12.2.5 Serial port 1 control register (SIO1CON)

Address: 0F28AH
 Access: R/W
 Access size: 8-bit
 Initial value: 00H

| | | | | | | | | |
|---------------|-----|-----|-----|-----|-----|-----|-----|------|
| | 7 | 6 | 5 | 4 | 3 | 2 | 1 | 0 |
| SIO1CON | — | — | — | — | — | — | — | S1EN |
| R/W | R/W | R/W | R/W | R/W | R/W | R/W | R/W | R/W |
| Initial value | 0 | 0 | 0 | 0 | 0 | 0 | 0 | 0 |

SIO1CON is a special function register (SFR) to control the synchronous serial port 1.

[Description of Bits]

- **S1EN** (bit 0)

The S1EN bit is used to specify start of synchronous serial communication. Writing a “1” to S1EN starts 8-/16-bit data communication. The S1EN bit is set to “0” automatically when 8-/16-bit data communication is terminated.

The S1EN bit is set to “0” at a system reset.

| S1EN | Description |
|------|--------------------------------------|
| 0 | Stops communication. (Initial value) |
| 1 | Starts communication |

12.2.6 Serial Port 0 Mode Register 0 (SIO0MOD0)

Address: 0F284H
 Access: R/W
 Access size: 8-bit
 Initial value: 00H

| | | | | | | | | |
|---------------|-----|-----|-----|-----|------|-------|-------|-------|
| | 7 | 6 | 5 | 4 | 3 | 2 | 1 | 0 |
| SIO0MOD0 | — | — | — | — | S0LG | S0MD1 | S0MD0 | S0DIR |
| R/W | R/W | R/W | R/W | R/W | R/W | R/W | R/W | R/W |
| Initial value | 0 | 0 | 0 | 0 | 0 | 0 | 0 | 0 |

SIO0MOD0 is a special function register (SFR) to set mode of the synchronous serial port 0.

[Description of Bits]

- **S0DIR** (bit 0)
 S0DIR is the bit for selecting LSB first or MSB first.

| S0DIR | Description |
|-------|---------------------------|
| 0 | LSB first (initial value) |
| 1 | MSB first |

- **S0MD1 and S0MD0** (bits 2 and 1)
 The S0MD1 and S0MD0 bits are used to select the transmit/receive mode of the synchronous serial port 0. The Receive mode, Transmit mode, or Transmit/Receive mode is selectable.

| S0MD1 | S0MD0 | Description |
|-------|-------|--|
| 0 | 0 | Stops transmission/reception (initial value) |
| 0 | 1 | Receive mode |
| 1 | 0 | Transmit mode |
| 1 | 1 | Transmit/receive mode |

- **S0LG** (bit 3)
 S0LG is the bit that specifies the transmit/receive buffer bit length. Either 8-bit length or 16-bit length can be selected.
 The S0LG bit is set to “0” at a system reset.

| S0LG | Description |
|------|------------------------------|
| 0 | 8-bit length (initial value) |
| 1 | 16-bit length |

Note:

- Do not change any of the SIO0MOD0 register settings during transmission/reception.
- When the synchronous serial port 0 is used, the tertiary functions of Port 4 must be set. For the tertiary functions of Port 4, see Chapter 17, “Port 4”.

12.2.7 Serial Port 1 Mode Register 0 (SIO1MOD0)

Address: 0F28CH
 Access: R/W
 Access size: 8-bit
 Initial value: 00H

| | | | | | | | | |
|---------------|-----|-----|-----|-----|------|-------|-------|-------|
| | 7 | 6 | 5 | 4 | 3 | 2 | 1 | 0 |
| SIO1MOD0 | — | — | — | — | S1LG | S1MD1 | S1MD0 | S1DIR |
| R/W | R/W | R/W | R/W | R/W | R/W | R/W | R/W | R/W |
| Initial value | 0 | 0 | 0 | 0 | 0 | 0 | 0 | 0 |

SIO1MOD0 is a special function register (SFR) to set mode of the synchronous serial port 1.

[Description of Bits]

- **S1DIR** (bit 0)
 S1DIR is the bit for selecting LSB first or MSB first.

| S1DIR | Description |
|-------|---------------------------|
| 0 | LSB first (initial value) |
| 1 | MSB first |

- **S1MD1 and S1MD0** (bits 2 and 1)
 The S1MD1 and S1MD0 bits are used to select the transmit/receive mode of the synchronous serial port 1. The Receive mode, Transmit mode, or Transmit/Receive mode is selectable.

| S1MD1 | S1MD0 | Description |
|-------|-------|--|
| 0 | 0 | Stops transmission/reception (initial value) |
| 0 | 1 | Receive mode |
| 1 | 0 | Transmit mode |
| 1 | 1 | Transmit/receive mode |

- **S1LG** (bit 3)
 S1LG is the bit that specifies the transmit/receive buffer bit length. Either 8-bit length or 16-bit length can be selected.
 The S1LG bit is set to “0” at a system reset.

| S1LG | Description |
|------|------------------------------|
| 0 | 8-bit length (initial value) |
| 1 | 16-bit length |

Note:

- Do not change any of the SIO1MOD0 register settings during transmission/reception.
- When the synchronous serial port 1 is used, the tertiary functions of Port 5 must be set. For the tertiary functions of Port 5, see Chapter 18, “Port 5”.

12.2.8 Serial Port 0 Mode Register 1 (SIO0MOD1)

Address: 0F285H
Access: R/W
Access size: 8-bit
Initial value: 00H

| | | | | | | | | |
|---------------|-----|-----|-------|-------|-----|-------|-------|-------|
| | 7 | 6 | 5 | 4 | 3 | 2 | 1 | 0 |
| SIO0MOD1 | — | — | S0NEG | S0CKT | — | S0CK2 | S0CK1 | S0CK0 |
| R/W | R/W | R/W | R/W | R/W | R/W | R/W | R/W | R/W |
| Initial value | 0 | 0 | 0 | 0 | 0 | 0 | 0 | 0 |

SIO0MOD1 is a special function register (SFR) to set mode of the synchronous serial port 0.

[Description of Bits]

- **S0CK2 to S0CK0** (bits 2 to 0)

The S0CK2 to S0CK0 bits are used to select the transfer clock of the synchronous serial port. When the internal clock is selected, this LSI is set to master mode and when the external clock is selected, it is set to slave mode.

| S0CK2 | S0CK1 | S0CK0 | Description |
|-------|-------|-------|-----------------------------|
| 0 | 0 | 0 | 32 KHz (initial value) |
| 0 | 0 | 1 | 16KHz |
| 0 | 1 | 0 | 1/4 HSCLK |
| 0 | 1 | 1 | 1/8 HSCLK |
| 1 | 0 | 0 | 1/16 HSCLK |
| 1 | 0 | 1 | 1/32 HSCLK |
| 1 | 1 | 0 | External clock 0 (P41/SCK0) |
| 1 | 1 | 1 | External clock 0 (P45/SCK0) |

- **S0CKT** (bit 4)

The S0CKT bit is used to select the phase of the transfer clock output.

| S0CKT | Description |
|-------|---|
| 0 | Clock type 0: Output at the "H" level by default (initial value). |
| 1 | Clock type 1: Output at the "L" level by default. |

- **S0NEG** (bit 5)

The S0NEG bit is used to select the positive or negative logic of the transfer clock output.

| S0NEG | Description |
|-------|--------------------------------|
| 0 | Positive logic (initial value) |
| 1 | Negative logic |

12.2.9 Serial Port 1 Mode Register 1 (SIO1MOD1)

Address: 0F28DH
 Access: R/W
 Access size: 8-bit
 Initial value: 00H

| | | | | | | | | |
|---------------|-----|-----|-------|-------|-----|-------|-------|-------|
| | 7 | 6 | 5 | 4 | 3 | 2 | 1 | 0 |
| SIO1MOD1 | — | — | S1NEG | S1CKT | — | S1CK2 | S1CK1 | S1CK0 |
| R/W | R/W | R/W | R/W | R/W | R/W | R/W | R/W | R/W |
| Initial value | 0 | 0 | 0 | 0 | 0 | 0 | 0 | 0 |

SIO1MOD1 is a special function register (SFR) to set mode of the synchronous serial port 1.

[Description of Bits]

- **S1CK2 to S1CK0** (bits 2 to 0)

The S1CK2 to S1CK0 bits are used to select the transfer clock of the synchronous serial port. When the internal clock is selected, this LSI is set to master mode and when the external clock is selected, it is set to slave mode.

| S1CK2 | S1CK1 | S1CK0 | Description |
|-------|-------|-------|-----------------------------|
| 0 | 0 | 0 | 32 KHz (initial value) |
| 0 | 0 | 1 | 16KHz |
| 0 | 1 | 0 | 1/4 HSCLK |
| 0 | 1 | 1 | 1/8 HSCLK |
| 1 | 0 | 0 | 1/16 HSCLK |
| 1 | 0 | 1 | 1/32 HSCLK |
| 1 | 1 | 0 | External clock 1 (P51/SCK1) |
| 1 | 1 | 1 | External clock 1 (P55/SCK1) |

- **S1CKT** (bit 4)

The S1CKT bit is used to select the phase of the transfer clock output.

| S1CKT | Description |
|-------|---|
| 0 | Clock type 0: Output at the "H" level by default (initial value). |
| 1 | Clock type 1: Output at the "L" level by default. |

- **S1NEG** (bit 5)

The S1NEG bit is used to select the positive or negative logic of the transfer clock output.

| S1NEG | Description |
|-------|--------------------------------|
| 0 | Positive logic (initial value) |
| 1 | Negative logic |

12.3 Description of Operation

12.3.1 Transmit Operation

When "1" is written to the SnMD1 bit and "0" is written to the SnMD0 bit of the serial port mode register (SIO nMOD0), this LSI is set to the transmit mode.

When transmitted data is written to the serial port transmit/receive buffer (SIO nBUFL, "H") and the SnEN bit of the serial port control register (SIO nCON) is set to "1", transmission starts. When transmission of 8/16-bit data terminates, a synchronous serial port interrupt (SIO nINT) occurs and the SnEN bit is set to "0".

The transmitted data is output from the Port 4's tertiary function (P42/SOUT0, P46/SOUT0) or from the Port 5's tertiary function (P52/SOUT1, P56/SOUT1).

When an internal clock is selected in the serial port mode register (SIO nMOD1), the LSI is set to a master mode and when an external clock (SCKn) is selected, the LSI is set to a slave mode.

The serial port mode register (SIO nMOD0) enables selection of MSB first/LSB first.

The transmitted data output pin (SOUTn) and the transfer clock input/output pin (SCKn) need to be set to the tertiary function for the Port 4 or to the tertiary function for the Port 5.

The transmission operation waveforms of the synchronous serial port (8-bit length, LSB first) are shown in Figures 12-2 to 12-5, for the clock type 0 (positive logic), clock type 0 (negative logic), clock type 1 (positive logic), and clock type 1 (negative logic), respectively.

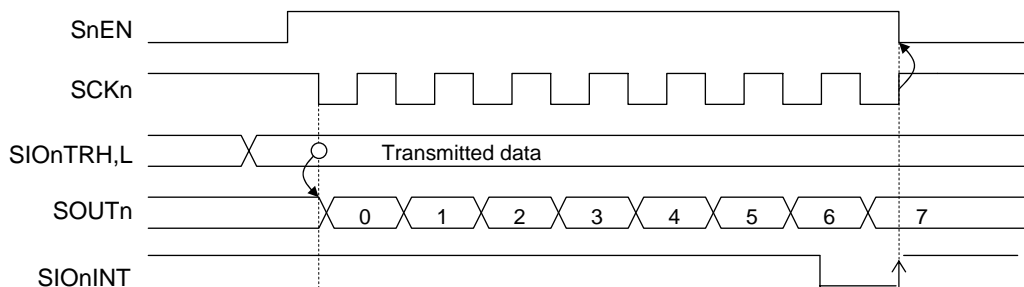

Figure 12-2 Transmit Operation Waveforms of Synchronous Serial Port for Clock Type 0 (Positive Logic)
 (8-bit length, LSB first, n = 0, 1)

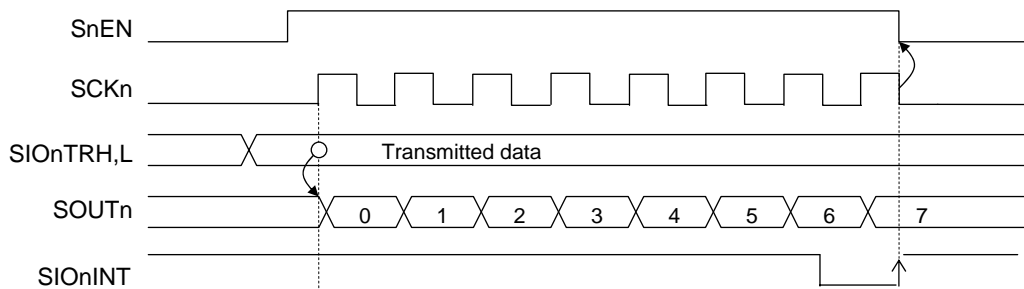

Figure 12-3 Transmit Operation Waveforms of Synchronous Serial Port for Clock Type 0 (Negative Logic)
 (8-bit length, LSB first, n = 0, 1)

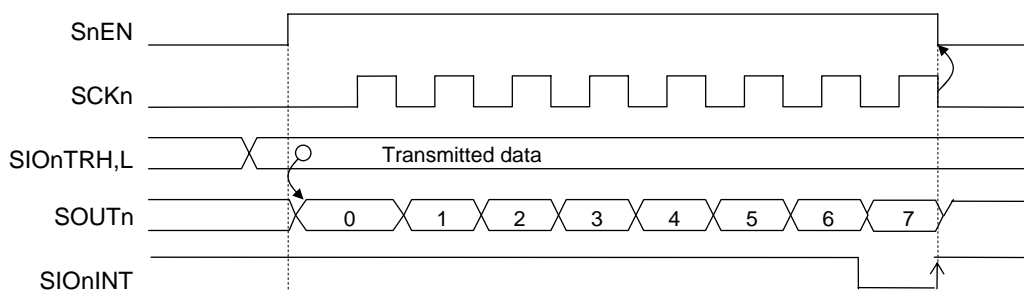

Figure 12-4 Transmit Operation Waveforms of Synchronous Serial Port for Clock Type 1 (Positive Logic)
 (8-bit length, LSB first, n = 0, 1)

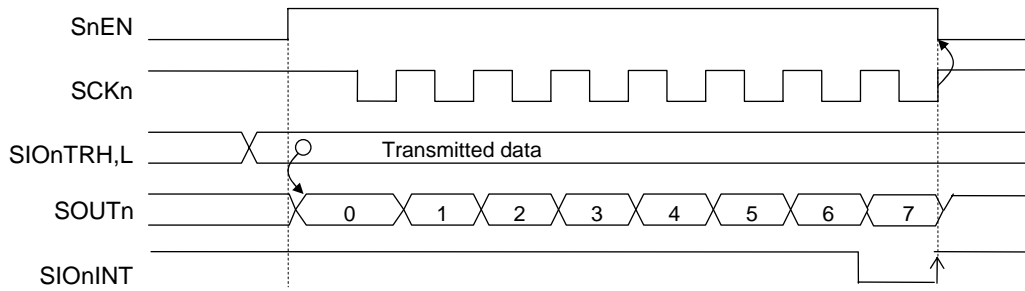

Figure 12-5 Transmit Operation Waveforms of Synchronous Serial Port for Clock Type 1 (Negative Logic)
(8-bit length, LSB first, n = 0, 1)

12.3.2 Receive Operation

When “0” is written to the SnMD1 bit and “1” is written to the SnMD0 bit of the serial port mode register (SIO_nMOD0), this LSI is set to a receive mode.

When the SnEN bit of the serial port control register (SIO_nCON) is set to “1”, reception starts. When reception of 8/16-bit data terminates, a synchronous serial port interrupt (SIO_nINT) occurs and the SnEN bit is set to “0”.

The received data is input from the tertiary function pins (P40/SIN0 or P44/SIN0) or the tertiary function pin (P50/SIN1, P54/SIN1) of GPIO.

When an internal clock is selected in the serial port mode register (SIO_nMOD1), the LSI is set to a master mode and when an external clock (SCK_n) is selected, the LSI is set to a slave mode.

The serial port mode register (SIO_nMOD0) enables selection of MSB first/LSB first.

The received data input pin (SIN_n) and the transfer clock input/output pin (SCK_n) need to be set to the tertiary function for the Port 4 or to the secondary function for the Port 5.

The receive operation waveforms of the synchronous serial port (8-bit length, MSB first) are shown in Figures 12-6 to 12-9, for the clock type 0 (positive logic), clock type 0 (negative logic), clock type 1 (positive logic), and clock type 1 (negative logic), respectively.

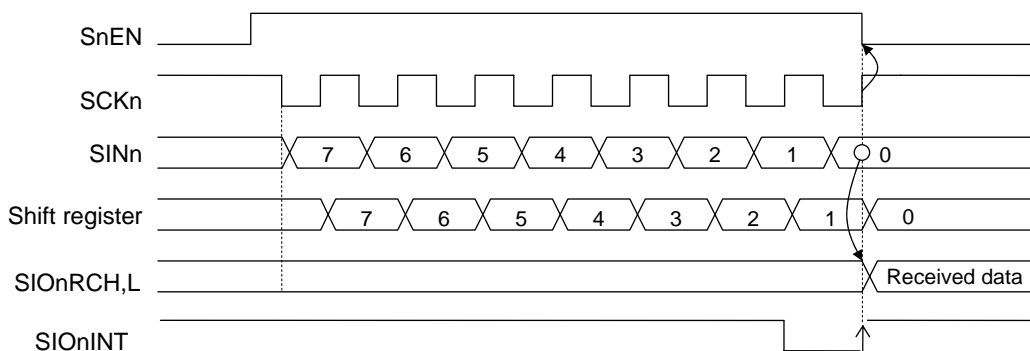

Figure 12-6 Receive Operation Waveforms of Synchronous Serial Port for Clock Type 0 (Positive Logic)
 (8-bit length, MSB first)

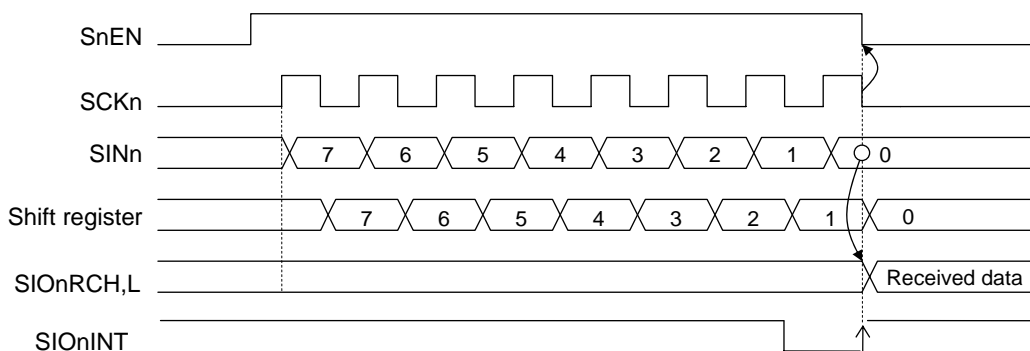

Figure 12-7 Receive Operation Waveforms of Synchronous Serial Port for Clock Type 0 (Negative Logic)
 (8-bit length, MSB first)

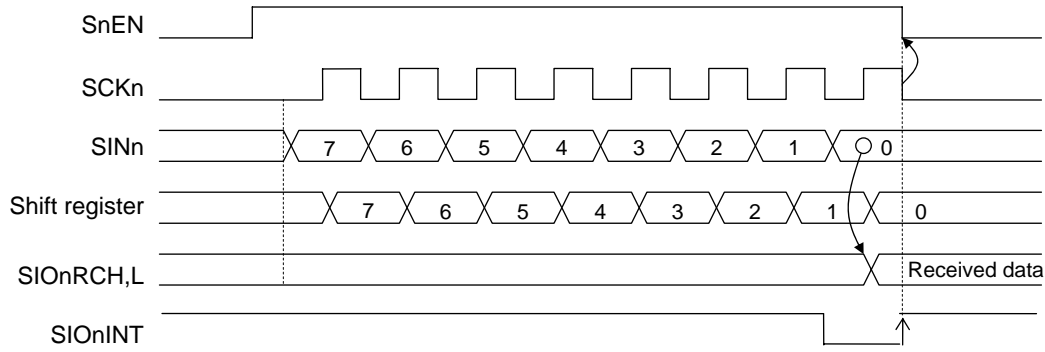

Figure 12-8 Receive Operation Waveforms of Synchronous Serial Port for Clock Type 1 (Positive Logic)
 (8-bit length, MSB first)

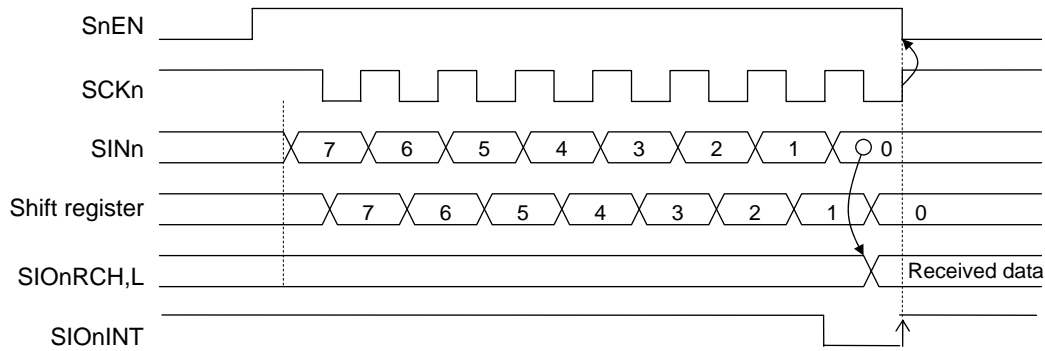

Figure 12-9 Receive Operation Waveforms of Synchronous Serial Port for Clock Type 1 (Negative Logic)
 (8-bit length, MSB first)

Note:

- When the SOUT0 pin is set to the tertiary function output in receive mode, a “H” level is output from the SOUT0 pin.
- When the SOUT1 pin is set to the tertiary function output in receive mode, a “H” level is output from the SOUT1 pin.

12.3.3 Transmit/Receive Operation

When "1" is written to the SnMD1 bit and "1" is written to the SnMD0 bit of the serial port mode register (SIO_nMOD0), this LSI is set to the transmit/receive mode.

When the SnEN bit of the serial port control register (SIO_nCON) is set to "1", transmission/reception starts. When transmission/reception of 8/16-bit data terminates, a synchronous serial port interrupt (SIO_nINT) occurs and the SnEN bit is set to "0".

The received data is input from the tertiary function pins (P40/SIN0 or P44/SIN0) or the tertiary function pin (P50/SIN1, P54/SIN1) of GPIO, and the transmitted data is output from the tertiary function pins (P42/SOUT0 or P46/SOUT0) or the tertiary function pin (P52/SOUT1) of GPIO.

When an internal clock is selected in the serial port mode register (SIO_nMOD1), the LSI is set to a master mode and when an external clock (SCK_n) is selected, the LSI is set to a slave mode.

The serial port mode register (SIO_nMOD0) enables selection of MSB first/LSB first.

The received data input pin (SIN_n), the transmitted data output pin (SOUT_n), and the transfer clock input/output pin (SCK_n) need to be set to the tertiary function for the Port 4 or to the secondary function for the Port 5.

Figure 12-10 shows the transmit/receive operation waveforms of the synchronous serial port (16-bit length, LSB first, clock types 0, positive logic).

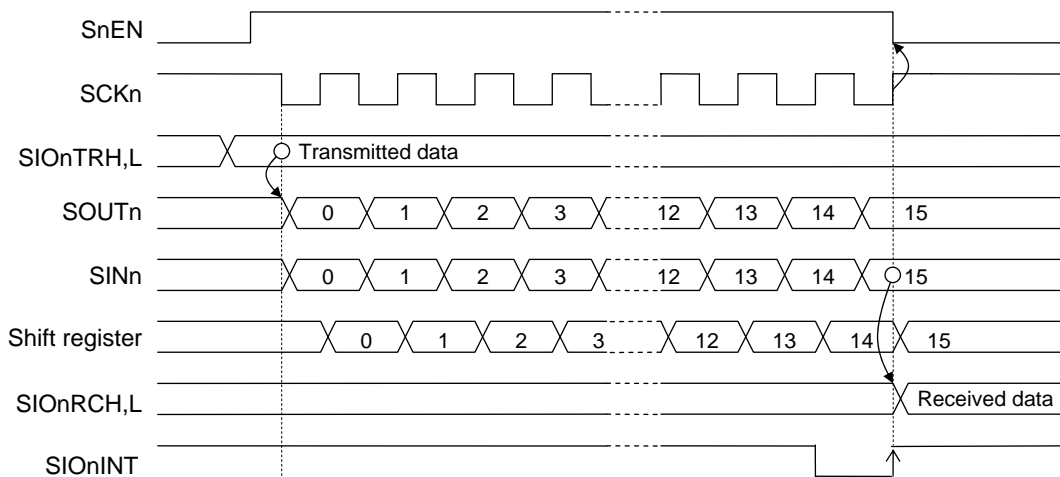

Figure 12-10 Transmit/Receive Operation Waveforms of Synchronous Serial Port (16-bit Length, LSB First, Clock Type 0, Positive Logic)

12.4 Specifying port registers

To enable the SSIO(SSIO0, SSIO1) function, the applicable bit of each related port register needs to be set. See Chapter 17, "Port 4" and Chapter 18 "Port 5" for detail about the port registers.

12.4.1 Functioning P42 (SOUT0: Output), P41 (SCK0: Input/output), and P40 (SIN0: Input) as the SSIO/ "Master mode"

Set the P42MD1 to P40MD1 bits (P4MOD1 register bits 2 to 0) to "1" and the P42MD0 to P40MD0 bits (P4MOD0 register bits 2 to 0) to "0" for selecting the SSIO as the tertiary function of the P42, P41 and P40.

| Register name | P4MOD1 register (Address: 0F225H) | | | | | | | |
|---------------|-----------------------------------|--------|--------|--------|--------|---------------|---------------|---------------|
| Bit | 7 | 6 | 5 | 4 | 3 | 2 | 1 | 0 |
| Bit name | P47MD1 | P46MD1 | P45MD1 | P44MD1 | P43MD1 | P42MD1 | P41MD1 | P40MD1 |
| Setting value | * | * | * | * | * | 1 | 1 | 1 |

| Register name | P4MOD0 register (Address: 0F224H) | | | | | | | |
|---------------|-----------------------------------|--------|--------|--------|--------|---------------|---------------|---------------|
| Bit | 7 | 6 | 5 | 4 | 3 | 2 | 1 | 0 |
| Bit name | P47MD0 | P46MD0 | P45MD0 | P44MD0 | P43MD0 | P42MD0 | P41MD0 | P40MD0 |
| Setting value | * | * | * | * | * | 0 | 0 | 0 |

Set P42C1-P41MC1 bits(bit2-bit1 of P4CON1 register) to "1", set P42C0-P41C0 bits(bit2-bit1 of P4CON0 register) to "1", and set P42DIR-P41DIR bits(bit2-bit1 of P4DIR register) to "0" for selecting the state mode of the P42 and P41 pins to CMOS output. Set the P40DIR bit (P4DIR register bit 0) to "1" for selecting the P40 as an input pin. The set value (\$) is arbitrary for the P40C1 and P40C0 bits. Select an arbitrary state mode depending on the state of the external circuit to which the P40 pin is connected.

| Register name | P4CON1 register (Address: 0F223H) | | | | | | | |
|---------------|-----------------------------------|-------|-------|-------|-------|--------------|--------------|--------------|
| Bit | 7 | 6 | 5 | 4 | 3 | 2 | 1 | 0 |
| Bit name | P47C1 | P46C1 | P45C1 | P44C1 | P43C1 | P42C1 | P41C1 | P40C1 |
| Setting value | * | * | * | * | * | 1 | 1 | \$ |

| Register name | P4CON0 register (Address: 0F222H) | | | | | | | |
|---------------|-----------------------------------|-------|-------|-------|-------|--------------|--------------|--------------|
| Bit | 7 | 6 | 5 | 4 | 3 | 2 | 1 | 0 |
| Bit name | P47C0 | P46C0 | P45C0 | P44C0 | P43C0 | P42C0 | P41C0 | P40C0 |
| Setting value | * | * | * | * | * | 1 | 1 | \$ |

| Register name | P4DIR register (Address: 0F221H) | | | | | | | |
|---------------|----------------------------------|--------|--------|--------|--------|---------------|---------------|---------------|
| Bit | 7 | 6 | 5 | 4 | 3 | 2 | 1 | 0 |
| Bit name | P47DIR | P46DIR | P45DIR | P44DIR | P43DIR | P42DIR | P41DIR | P40DIR |
| Setting value | * | * | * | * | * | 0 | 0 | 1 |

The data of the P42D to P40D bits (P4D register bits 2 to 0) can either be "0" or "1".

| Register name | P4D register (Address: 0F220H) | | | | | | | |
|---------------|--------------------------------|------|------|------|------|-------------|-------------|-------------|
| Bit | 7 | 6 | 5 | 4 | 3 | 2 | 1 | 0 |
| Bit name | P47D | P46D | P45D | P44D | P43D | P42D | P41D | P40D |
| Setting value | * | * | * | * | * | ** | ** | ** |

* : Bit not related to the SSIO0 function

** : Don't care

\$: Optional

12.4.2 Functioning P42 (SOUT0: Output), P41 (SCK0: Input/output), and P40 (SIN0: Input) as the SSIO0/ "Slave mode"

Set the P42MD1 to P40MD1 bits (P4MOD1 register bits 2 to 0) to "1" and the P42MD0 to P40MD0 bits (P4MOD0 register bits 2 to 0) to "0" for selecting the SSIO as the tertiary function of the P42, P41 and P40. They are the same setting as those in the case of master mode.

| Register name | P4MOD1 register (Address: 0F225H) | | | | | | | |
|---------------|-----------------------------------|--------|--------|--------|--------|---------------|---------------|---------------|
| Bit | 7 | 6 | 5 | 4 | 3 | 2 | 1 | 0 |
| Bit name | P47MD1 | P46MD1 | P45MD1 | P44MD1 | P43MD1 | P42MD1 | P41MD1 | P40MD1 |
| Setting value | * | * | * | * | * | 1 | 1 | 1 |

| Register name | P4MOD0 register (Address: 0F224H) | | | | | | | |
|---------------|-----------------------------------|--------|--------|--------|--------|---------------|---------------|---------------|
| Bit | 7 | 6 | 5 | 4 | 3 | 2 | 1 | 0 |
| Bit name | P47MD0 | P46MD0 | P45MD0 | P44MD0 | P43MD0 | P42MD0 | P41MD0 | P40MD0 |
| Setting value | * | * | * | * | * | 0 | 0 | 0 |

Set the P42C1 bit (P4CON1 register bit 2) to "1", the P42C0 bit (P4CON0 register bit 2) to "1", and the P42DIR bit (P4DIR register bit 2) to "0" for selecting the P42 pin state mode to CMOS output.

Set P41DIR to P40DIR bits (P4DIR register bit 1 to 0) to "1" for specifying the P41 and P40 as input pins.

The set value (\$) is arbitrary for the P41C1 to P40C1 bits and for the P41C0 to P40C0 bits. Select an arbitrary input mode depending on the state of the external circuit to which the P41 or P40 pin is connected.

| Register name | P4CON1 register (Address: 0F223H) | | | | | | | |
|---------------|-----------------------------------|-------|-------|-------|-------|--------------|--------------|--------------|
| Bit | 7 | 6 | 5 | 4 | 3 | 2 | 1 | 0 |
| Bit name | P47C1 | P46C1 | P45C1 | P44C1 | P43C1 | P42C1 | P41C1 | P40C1 |
| Setting value | * | * | * | * | * | 1 | \$ | \$ |

| Register name | P4CON0 register (Address: 0F222H) | | | | | | | |
|---------------|-----------------------------------|-------|-------|-------|-------|--------------|--------------|--------------|
| Bit | 7 | 6 | 5 | 4 | 3 | 2 | 1 | 0 |
| Bit name | P47C0 | P46C0 | P45C0 | P44C0 | P43C0 | P42C0 | P41C0 | P40C0 |
| Setting value | * | * | * | * | * | 1 | \$ | \$ |

| Register name | P4DIR register (Address: 0F221H) | | | | | | | |
|---------------|----------------------------------|--------|--------|--------|--------|---------------|---------------|---------------|
| Bit | 7 | 6 | 5 | 4 | 3 | 2 | 1 | 0 |
| Bit name | P47DIR | P46DIR | P45DIR | P44DIR | P43DIR | P42DIR | P41DIR | P40DIR |
| Setting value | * | * | * | * | * | 0 | 1 | 1 |

The data of the P42D to P40D bits (P4D register bits 2 to 0) can either be "0" or "1".

| Register name | P4D register (Address: 0F220H) | | | | | | | |
|---------------|--------------------------------|------|------|------|------|-------------|-------------|-------------|
| Bit | 7 | 6 | 5 | 4 | 3 | 2 | 1 | 0 |
| Bit name | P47D | P46D | P45D | P44D | P43D | P42D | P41D | P40D |
| Setting value | * | * | * | * | * | ** | ** | ** |

* : Bit not related to the SSIO0 function

** : Don't care

\$: Optional

12.4.3 Functioning P46 (SOUT0: Output), P45 (SCK0: Input/output) and P44 (SIN0: Input) as the SSIO0/ "Master mode"

Set P46MD1-P44MD1 bits(bit6-bit4 of P4MOD1 register) to "1" and set P46MD0-P44MD0(bit6-bit4 of P4MOD0 register) to "0", for specifying the SSIO0 as the tertialy function of P46, P45 and P44. Set P40MD1 bit(bit0 of P4MOD1) to "0", and set P40 to be primaly or secondary function as not to be SSIO function.

| Register name | P4MOD1 register (Address: 0F225H) | | | | | | | |
|---------------|-----------------------------------|---------------|---------------|---------------|--------|--------|--------|---------------|
| Bit | 7 | 6 | 5 | 4 | 3 | 2 | 1 | 0 |
| Bit name | P47MD1 | P46MD1 | P45MD1 | P44MD1 | P43MD1 | P42MD1 | P41MD1 | P40MD1 |
| Setting value | * | 1 | 1 | 1 | * | * | * | 0 |

| Register name | P4MOD0 register (Address: 0F224H) | | | | | | | |
|---------------|-----------------------------------|---------------|---------------|---------------|--------|--------|--------|--------|
| Bit | 7 | 6 | 5 | 4 | 3 | 2 | 1 | 0 |
| Bit name | P47MD0 | P46MD0 | P45MD0 | P44MD0 | P43MD0 | P42MD0 | P41MD0 | P40MD0 |
| Setting value | * | 0 | 0 | 0 | * | * | * | * |

Set P46C1-P45MC1 bits(bit6-bit5 of P4CON1 register) to "1", set P46C0-P45C0 bits(bit6-bit5 of P4CON0 register) to "1", and set P46DIR-P45DIR bits(bit6-bit5 of P4DIR register) to "0" for selecting the state mode of the P46 and P45 pins to CMOS output. Set P44DIR bit(bit4 of P4DIR register) to "1" for specifying the P44 as an input pin. The set value (\$) is arbitrary for the P44C1 and P44C0 bits. Select an arbitrary state mode depending on the state of the external circuit to which the P44 pin is connected.

| Register name | P4CON1 register (Address: 0F223H) | | | | | | | |
|---------------|-----------------------------------|--------------|--------------|--------------|-------|-------|-------|-------|
| Bit | 7 | 6 | 5 | 4 | 3 | 2 | 1 | 0 |
| Bit name | P47C1 | P46C1 | P45C1 | P44C1 | P43C1 | P42C1 | P41C1 | P40C1 |
| Setting value | * | 1 | 1 | \$ | * | * | * | * |

| Register name | P4CON0 register (Address: 0F222H) | | | | | | | |
|---------------|-----------------------------------|--------------|--------------|--------------|-------|-------|-------|-------|
| Bit | 7 | 6 | 5 | 4 | 3 | 2 | 1 | 0 |
| Bit name | P47C0 | P46C0 | P45C0 | P44C0 | P43C0 | P42C0 | P41C0 | P40C0 |
| Setting value | * | 1 | 1 | \$ | * | * | * | * |

| Register name | P4DIR register (Address: 0F221H) | | | | | | | |
|---------------|----------------------------------|---------------|---------------|---------------|--------|--------|--------|--------|
| Bit | 7 | 6 | 5 | 4 | 3 | 2 | 1 | 0 |
| Bit name | P47DIR | P46DIR | P45DIR | P44DIR | P43DIR | P42DIR | P41DIR | P40DIR |
| Setting value | * | 0 | 0 | 1 | * | * | * | * |

The P46D to P44D bits (P4D register bits 6 to 4) data can either be "0" or "1" (not need to be set).

| Register name | P4D register (Address: 0F220H) | | | | | | | |
|---------------|--------------------------------|-------------|-------------|-------------|------|------|------|------|
| Bit | 7 | 6 | 5 | 4 | 3 | 2 | 1 | 0 |
| Bit name | P47D | P46D | P45D | P44D | P43D | P42D | P41D | P40D |
| Setting value | * | ** | ** | ** | * | * | * | * |

* : Bit not related to the SSIO0 function

** : Don't care

\$: Optional

12.4.4 Functioning P46 (SOUT0: Output), P45 (SCK0: Input/output) and P44 (SIN0: Input) as the SSIO0/ "Slave mode"

Set P46MD1-P44MD1 bits(bit6-bit4 of P4MOD1 register) to "1" and set P46MD0-P44MD0(bit6-bit4 of P4MOD0 register) to "0", for specifying the SSIO0 as the tertiary function of P46, P45 and P44. Set P40MD1 bit(bit0 of P4MOD1) to "0", and set P40 to be primary or secondary function as not to be SSIO function. They are the same setting as those in the case of master mode.

| Register name | P4MOD1 register (Address: 0F225H) | | | | | | | |
|---------------|-----------------------------------|---------------|---------------|---------------|--------|--------|--------|---------------|
| Bit | 7 | 6 | 5 | 4 | 3 | 2 | 1 | 0 |
| Bit name | P47MD1 | P46MD1 | P45MD1 | P44MD1 | P43MD1 | P42MD1 | P41MD1 | P40MD1 |
| Setting value | * | 1 | 1 | 1 | * | * | * | 0 |

| Register name | P4MOD0 register (Address: 0F224H) | | | | | | | |
|---------------|-----------------------------------|---------------|---------------|---------------|--------|--------|--------|--------|
| Bit | 7 | 6 | 5 | 4 | 3 | 2 | 1 | 0 |
| Bit name | P47MD0 | P46MD0 | P45MD0 | P44MD0 | P43MD0 | P42MD0 | P41MD0 | P40MD0 |
| Setting value | * | 0 | 0 | 0 | * | * | * | * |

Set P46C1 bit(bit6 of P4CON1 register) to "1", set P46C0 bit(bit6 of P4CON0 register) to "1", and set P46DIR bit(bit6 of P4DIR register) to "0" for selecting the P46 pin state mode to CMOS output.

Set P45DIR-P44DIR bits(bit5-4 of P4DIR register) to "1" for specifying the P45 and P44 as input pins.

The set value (\$) is arbitrary for the P45C1 to P44C1 bits and for the P45C0 to P44C0 bits. Select an arbitrary input mode depending on the state of the external circuit to which the P45 or P44 pin is connected.

| Register name | P4CON1 register (Address: 0F223H) | | | | | | | |
|---------------|-----------------------------------|--------------|--------------|--------------|-------|-------|-------|-------|
| Bit | 7 | 6 | 5 | 4 | 3 | 2 | 1 | 0 |
| Bit name | P47C1 | P46C1 | P45C1 | P44C1 | P43C1 | P42C1 | P41C1 | P40C1 |
| Setting value | * | 1 | \$ | \$ | * | * | * | * |

| Register name | P4CON0 register (Address: 0F222H) | | | | | | | |
|---------------|-----------------------------------|--------------|--------------|--------------|-------|-------|-------|-------|
| Bit | 7 | 6 | 5 | 4 | 3 | 2 | 1 | 0 |
| Bit name | P47C0 | P46C0 | P45C0 | P44C0 | P43C0 | P42C0 | P41C0 | P40C0 |
| Setting value | * | 1 | \$ | \$ | * | * | * | * |

| Register name | P4DIR register (Address: 0F221H) | | | | | | | |
|---------------|----------------------------------|---------------|---------------|---------------|--------|--------|--------|--------|
| Bit | 7 | 6 | 5 | 4 | 3 | 2 | 1 | 0 |
| Bit name | P47DIR | P46DIR | P45DIR | P44DIR | P43DIR | P42DIR | P41DIR | P40DIR |
| Setting value | * | 0 | 1 | 1 | * | * | * | * |

The P46D to P44D bits (P4D register bits 6 to 4) data can either be "0" or "1" (not need to be set).

| Register name | P4D register (Address: 0F220H) | | | | | | | |
|---------------|--------------------------------|-------------|-------------|-------------|------|------|------|------|
| Bit | 7 | 6 | 5 | 4 | 3 | 2 | 1 | 0 |
| Bit name | P47D | P46D | P45D | P44D | P43D | P42D | P41D | P40D |
| Setting value | * | ** | ** | ** | * | * | * | * |

* : Bit not related to the SSIO0 function

** : Don't care

\$: Optional

12.4.5 Functioning P52 (SOUT1: Output), P51 (SCK1: Input/output), and P50 (SIN1: Input) as the SSIO1/ "Master mode"

Set the P52MD1 to P50MD1 bits (P5MOD1 register bits 2 to 0) to "1", and set the P52MD0 to P50MD0 bits (P5MOD0 register bits 2 to 0) to "0" for specifying the SSIO1 as the secondary function of the P52, P51, and P50.

| Register name | P5MOD1 register (address: 0F22DH) | | | | | | | |
|---------------|-----------------------------------|--------|--------|--------|---|---------------|---------------|---------------|
| Bit | 7 | 6 | 5 | 4 | 3 | 2 | 1 | 0 |
| Bit name | — | P56MD1 | P55MD1 | P54MD1 | — | P52MD1 | P51MD1 | P50MD1 |
| Setting value | * | * | * | * | * | 1 | 1 | 1 |

| Register name | P5MOD0 register (address: 0F22CH) | | | | | | | |
|---------------|-----------------------------------|--------|--------|--------|---|---------------|---------------|---------------|
| Bit | 7 | 6 | 5 | 4 | 3 | 2 | 1 | 0 |
| Bit name | — | P56MD0 | P55MD0 | P54MD0 | — | P52MD0 | P51MD0 | P50MD0 |
| Setting value | * | * | * | * | * | 0 | 0 | 0 |

Set the P52C0 to P51C0 bits (P5CON0 register bits 2 to 1) to "1", and the P52DIR to P51DIR bits (P5DIR register bits 2 to 1) to "0" for selecting the P52 and P51 pin state mode to CMOS output. Set the P50DIR bit (P5DIR register bit 0) to "1" for selecting the P50 as an input pin.

The set value (\$) is arbitrary for the P5UD and P50C0 bits. Select an arbitrary state mode depending on the state of the external circuit to which the P50 pin is connected.

| Register name | P5CON1 register (address: 0F22BH) | | | | | | | |
|---------------|-----------------------------------|---|---|---|---|---|---|-------------|
| Bit | 7 | 6 | 5 | 4 | 3 | 2 | 1 | 0 |
| Bit name | — | — | — | — | — | — | — | P5UD |
| Setting value | * | * | * | * | * | * | * | \$ |

| Register name | P5CON0 register (address: 0F22AH) | | | | | | | |
|---------------|-----------------------------------|-------|-------|-------|-------|--------------|--------------|--------------|
| Bit | 7 | 6 | 5 | 4 | 3 | 2 | 1 | 0 |
| Bit name | P57C0 | P56C0 | P55C0 | P54C0 | P53C0 | P52C0 | P51C0 | P50C0 |
| Setting value | * | * | * | * | * | 1 | 1 | \$ |

| Register name | P5DIR register (address: 0F229H) | | | | | | | |
|---------------|----------------------------------|--------|--------|--------|--------|---------------|---------------|---------------|
| Bit | 7 | 6 | 5 | 4 | 3 | 2 | 1 | 0 |
| Bit name | P57DIR | P56DIR | P55DIR | P54DIR | P53DIR | P52DIR | P51DIR | P50DIR |
| Setting value | * | * | * | * | * | 0 | 0 | 1 |

The P52D to P50D bits (P5D register bits 2 to 0) data can either be "0" or "1" (not need to be set).

| Register name | P5D register (address: 0F228H) | | | | | | | |
|---------------|--------------------------------|------|------|------|------|-------------|-------------|-------------|
| Bit | 7 | 6 | 5 | 4 | 3 | 2 | 1 | 0 |
| Bit name | P57D | P56D | P55D | P54D | P53D | P52D | P51D | P50D |
| Setting value | * | * | * | * | * | ** | ** | ** |

* : Bit not related to the SSIO1 function

** : Don't care

\$: Optional

12.4.6 Functioning P52 (SOUT1: Output), P51 (SCK1: Input/output), and P50 (SIN1: Input) as the SSIO1/ "Slave mode"

Set the P52MD1 to P50MD1 bits (P5MOD1 register bits 2 to 0) to "1", and set the P52MD0 to P50MD0 bits (P5MOD0 register bits 2 to 0) to "0" for specifying the SSIO as the tertiary function of the P52, P51, and P50. They are the same setting as those in the case of master mode.

| Register name | P5MOD1 register (address: 0F22DH) | | | | | | | |
|---------------|-----------------------------------|--------|--------|--------|---|---------------|---------------|---------------|
| Bit | 7 | 6 | 5 | 4 | 3 | 2 | 1 | 0 |
| Bit name | — | P56MD1 | P55MD1 | P54MD1 | — | P52MD1 | P51MD1 | P50MD1 |
| Setting value | * | * | * | * | * | 1 | 1 | 1 |

| Register name | P5MOD0 register (address: 0F22CH) | | | | | | | |
|---------------|-----------------------------------|--------|--------|--------|---|---------------|---------------|---------------|
| Bit | 7 | 6 | 5 | 4 | 3 | 2 | 1 | 0 |
| Bit name | — | P56MD0 | P55MD0 | P54MD0 | — | P52MD0 | P51MD0 | P50MD0 |
| Setting value | * | * | * | * | * | 0 | 0 | 0 |

Set the P52C0 bit (P5CON0 register bit 2) to "1", and the P52DIR bit (P5DIR register bit 2) to "0" for selecting the P52 pin state mode to CMOS output.

Set P51DIR to P50DIR bits (P5DIR register bits 1 to 0) to "1" for selecting the P51 and P50 as input pins.

The set value (\$) is arbitrary for the P5UD bits and for the P51C0 to P50C0 bits. Select an arbitrary input mode depending on the state of the external circuit to which the P51 or P50 pin is connected.

| Register name | P5CON1 register (address: 0F22BH) | | | | | | | |
|---------------|-----------------------------------|---|---|---|---|---|---|-------------|
| Bit | 7 | 6 | 5 | 4 | 3 | 2 | 1 | 0 |
| Bit name | — | — | — | — | — | — | — | P5UD |
| Setting value | * | * | * | * | * | * | * | \$ |

| Register name | P5CON0 register (address: 0F22AH) | | | | | | | |
|---------------|-----------------------------------|-------|-------|-------|-------|--------------|--------------|--------------|
| Bit | 7 | 6 | 5 | 4 | 3 | 2 | 1 | 0 |
| Bit name | P57C0 | P56C0 | P55C0 | P54C0 | P53C0 | P52C0 | P51C0 | P50C0 |
| Setting value | * | * | * | * | * | 1 | \$ | \$ |

| Register name | P5DIR register (address: 0F229H) | | | | | | | |
|---------------|----------------------------------|--------|--------|--------|--------|---------------|---------------|---------------|
| Bit | 7 | 6 | 5 | 4 | 3 | 2 | 1 | 0 |
| Bit name | P57DIR | P56DIR | P55DIR | P54DIR | P53DIR | P52DIR | P51DIR | P50DIR |
| Setting value | * | * | * | * | * | 0 | 1 | 1 |

The P52D to P50D bits (P5D register bits 2 to 0) data can either be "0" or "1" (not need to be set).

| Register name | P5D register (address: 0F228H) | | | | | | | |
|---------------|--------------------------------|------|------|------|------|-------------|-------------|-------------|
| Bit | 7 | 6 | 5 | 4 | 3 | 2 | 1 | 0 |
| Bit name | P57D | P56D | P55D | P54D | P53D | P52D | P51D | P50D |
| Setting value | * | * | * | * | * | ** | ** | ** |

* : Bit not related to the SSIO1 function

** : Don't care

\$: Optional

12.4.7 Functioning P56 (SOUT1: Output), P55 (SCK1: Input/output), and P54 (SIN1: Input) as the SSIO1/ "Master mode"

Set the P56MD1 to P54MD1 bits (P5MOD1 register bits 6 to 4) to "1", and set the P56MD0 to P54MD0 bits (P5MOD0 register bits 6 to 4) to "0" for specifying the SSIO1 as the secondary function of the P56, P55, and P54.

| Register name | P5MOD1 register (address: 0F22DH) | | | | | | | |
|---------------|-----------------------------------|---------------|---------------|---------------|---|--------|--------|--------|
| Bit | 7 | 6 | 5 | 4 | 3 | 2 | 1 | 0 |
| Bit name | — | P56MD1 | P55MD1 | P54MD1 | — | P52MD1 | P51MD1 | P50MD1 |
| Setting value | * | 1 | 1 | 1 | * | * | * | * |

| Register name | P5MOD0 register (address: 0F22CH) | | | | | | | |
|---------------|-----------------------------------|---------------|---------------|---------------|---|--------|--------|--------|
| Bit | 7 | 6 | 5 | 4 | 3 | 2 | 1 | 0 |
| Bit name | — | P56MD0 | P55MD0 | P54MD0 | — | P52MD0 | P51MD0 | P50MD0 |
| Setting value | * | 0 | 0 | 0 | * | * | * | * |

Set the P56C0 to P55C0 bits (P5CON0 register bits 6 to 5) to "1", and the P56DIR to P55DIR bits (P5DIR register bits 6 to 5) to "0" for selecting the P56 and P55 pin state mode to CMOS output. Set the P54DIR bit (P5DIR register bit 4) to "1" for selecting the P54 as an input pin.

The set value (\$) is arbitrary for the P5UD and P54C0 bits. Select an arbitrary state mode depending on the state of the external circuit to which the P54 pin is connected.

| Register name | P5CON1 register (address: 0F22BH) | | | | | | | |
|---------------|-----------------------------------|---|---|---|---|---|---|-------------|
| Bit | 7 | 6 | 5 | 4 | 3 | 2 | 1 | 0 |
| Bit name | — | — | — | — | — | — | — | P5UD |
| Setting value | * | * | * | * | * | * | * | \$ |

| Register name | P5CON0 register (address: 0F22AH) | | | | | | | |
|---------------|-----------------------------------|--------------|--------------|--------------|-------|-------|-------|-------|
| Bit | 7 | 6 | 5 | 4 | 3 | 2 | 1 | 0 |
| Bit name | P57C0 | P56C0 | P55C0 | P54C0 | P53C0 | P52C0 | P51C0 | P50C0 |
| Setting value | * | 1 | 1 | \$ | * | * | * | * |

| Register name | P5DIR register (address: 0F229H) | | | | | | | |
|---------------|----------------------------------|---------------|---------------|---------------|--------|--------|--------|--------|
| Bit | 7 | 6 | 5 | 4 | 3 | 2 | 1 | 0 |
| Bit name | P57DIR | P56DIR | P55DIR | P54DIR | P53DIR | P52DIR | P51DIR | P50DIR |
| Setting value | * | 0 | 0 | 1 | * | * | * | * |

The P56D to P54D bits (P5D register bits 6 to 4) data can either be "0" or "1" (not need to be set).

| Register name | P5D register (address: 0F228H) | | | | | | | |
|---------------|--------------------------------|------|------|------|------|------|------|------|
| Bit | 7 | 6 | 5 | 4 | 3 | 2 | 1 | 0 |
| Bit name | P57D | P56D | P55D | P54D | P53D | P52D | P51D | P50D |
| Setting value | * | ** | ** | ** | * | * | * | * |

* : Bit not related to the SSIO1 function

** : Don't care

\$: Optional

12.4.8 Functioning P56 (SOUT1: Output), P55 (SCK1: Input/output), and P54 (SIN1: Input) as the SSIO1/ "Slave mode"

Set the P56MD1 to P54MD1 bits (P5MOD1 register bits 6 to 4) to "1", and set the P56MD0 to P54MD0 bits (P5MOD0 register bits 6 to 4) to "0" for specifying the SSIO as the tertiary function of the P52, P51, and P50. They are the same setting as those in the case of master mode.

| Register name | P5MOD1 register (address: 0F22DH) | | | | | | | |
|---------------|-----------------------------------|---------------|---------------|---------------|---|--------|--------|---------------|
| Bit | 7 | 6 | 5 | 4 | 3 | 2 | 1 | 0 |
| Bit name | — | P56MD1 | P55MD1 | P54MD1 | — | P52MD1 | P51MD1 | P50MD1 |
| Setting value | * | 1 | 1 | 1 | * | * | * | 1 |

| Register name | P5MOD0 register (address: 0F22CH) | | | | | | | |
|---------------|-----------------------------------|---------------|---------------|---------------|---|--------|--------|--------|
| Bit | 7 | 6 | 5 | 4 | 3 | 2 | 1 | 0 |
| Bit name | — | P56MD0 | P55MD0 | P54MD0 | — | P52MD0 | P51MD0 | P50MD0 |
| Setting value | * | 0 | 0 | 0 | * | * | * | * |

Set the P56C0 bit (P5CON0 register bit 6) to "1", and the P56DIR bit (P5DIR register bit 6) to "0" for selecting the P56 pin state mode to CMOS output.

Set P55DIR to P54DIR bits (P5DIR register bits 5 to 4) to "1" for selecting the P55 and P54 as input pins.

The set value (\$) is arbitrary for the P5UD bits and for the P55C0 to P54C0 bits. Select an arbitrary input mode depending on the state of the external circuit to which the P55 or P54 pin is connected.

| Register name | P5CON1 register (address: 0F22BH) | | | | | | | |
|---------------|-----------------------------------|---|---|---|---|---|---|-------------|
| Bit | 7 | 6 | 5 | 4 | 3 | 2 | 1 | 0 |
| Bit name | — | — | — | — | — | — | — | P5UD |
| Setting value | * | * | * | * | * | * | * | \$ |

| Register name | P5CON0 register (address: 0F22AH) | | | | | | | |
|---------------|-----------------------------------|--------------|--------------|--------------|-------|-------|-------|-------|
| Bit | 7 | 6 | 5 | 4 | 3 | 2 | 1 | 0 |
| Bit name | P57C0 | P56C0 | P55C0 | P54C0 | P53C0 | P52C0 | P51C0 | P50C0 |
| Setting value | * | 1 | \$ | \$ | * | * | * | * |

| Register name | P5DIR register (address: 0F229H) | | | | | | | |
|---------------|----------------------------------|---------------|---------------|---------------|--------|--------|--------|--------|
| Bit | 7 | 6 | 5 | 4 | 3 | 2 | 1 | 0 |
| Bit name | P57DIR | P56DIR | P55DIR | P54DIR | P53DIR | P52DIR | P51DIR | P50DIR |
| Setting value | * | 0 | 1 | 1 | * | * | * | * |

The P56D to P54D bits (P5D register bits 6 to 4) data can either be "0" or "1" (not need to be set).

| Register name | P5D register (address: 0F228H) | | | | | | | |
|---------------|--------------------------------|-------------|-------------|-------------|------|------|------|------|
| Bit | 7 | 6 | 5 | 4 | 3 | 2 | 1 | 0 |
| Bit name | P57D | P56D | P55D | P54D | P53D | P52D | P51D | P50D |
| Setting value | * | ** | ** | ** | * | * | * | * |

* : Bit not related to the SSIO1 function

** : Don't care

\$: Optional

Chapter 13

UART

13. UART

13.1 Overview

This LSI includes 1 channel of UART (Universal Asynchronous Receiver Transmitter) which is an asynchronous serial interface.

For the input clock, see Chapter 6, "Clock Generation Circuit".

The use of UART requires setting of the secondary functions of Port 4. For the secondary functions of Port 4, see Chapter 17, "Port 4".

13.1.1 Features

- 5-bit/6-bit/7-bit/8-bit data length selectable.
- Odd parity, even parity, or no parity selectable.
- 1 stop bit or 2 stop bits selectable.
- Provided with parity error flag, overrun error flag, framing error flag, and transmit buffer status flag.
- Positive logic or negative logic selectable as communication logic.
- LSB first or MSB first selectable as a communication direction.
- Communication speed: Settable within the range of 200bps to 38400bps.
- Built-in baud rate generator.

13.1.2 Configuration

Figure 13-1 shows the configuration of the UART.

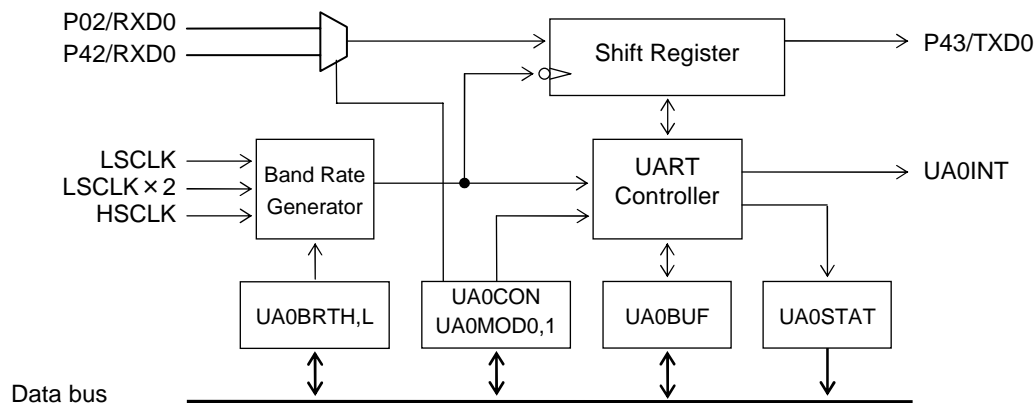

| | |
|-----------|---------------------------------|
| UA0BUF | : UART0 transmit/receive buffer |
| UA0BRTH,L | : UART0 baud rate H and L are: |
| UA0CON | : UART0 control register |
| UA0MOD0,1 | : UART0 mode registers 0 and 1 |
| UA0STAT | : UART0 status register |

Figure 13-1 Configuration of UART

13.1.3 List of Pins

| Pin name | I/O | Function |
|----------|-----|--|
| P02/RXD0 | I | UART0 data input pin Used for the primary function of the P02 pin. |
| P42/RXD0 | I | UART0 data input pin Used for the secondary function of the P42 pin. |
| P43/TXD0 | O | UART0 data output pin Used for the secondary function of the P43 pin. |

13.2 Description of Registers

13.2.1 List of Registers

| Address | Name | Symbol (Byte) | Symbol (Word) | R/W | Size | Initial value |
|---------|-------------------------------|---------------|---------------|-----|------|---------------|
| 0F290H | UART0 transmit/receive buffer | UA0BUF | — | R/W | 8 | 00H |
| 0F291H | UART0 control register | UA0CON | — | R/W | 8 | 00H |
| 0F292H | UART0 mode register 0 | UA0MOD0 | UA0MOD | R/W | 8/16 | 00H |
| 0F293H | UART0 mode register 1 | UA0MOD1 | | R/W | 8 | 00H |
| 0F294H | UART0 baud rate register L | UA0BRTL | UA0BRT | R/W | 8/16 | 0FFH |
| 0F295H | UART0 baud rate register H | UA0BRTH | | R/W | 8 | 0FH |
| 0F296H | UART0 status register | UA0STAT | — | R/W | 8 | 00H |

13.2.2 UART0 Transmit/Receive Buffer (UA0BUF)

Address: 0F290H

Access: R/W

Access size: 8-bit

Initial value: 00H

| | 7 | 6 | 5 | 4 | 3 | 2 | 1 | 0 |
|---------------|------|------|------|------|------|------|------|------|
| UA0BUF | U0B7 | U0B6 | U0B5 | U0B4 | U0B3 | U0B2 | U0B1 | U0B0 |
| R/W | R/W | R/W | R/W | R/W | R/W | R/W | R/W | R/W |
| Initial value | 0 | 0 | 0 | 0 | 0 | 0 | 0 | 0 |

UA0BUF is a special function register (SFR) to store the transmitted/received data of the UART.

In transmit mode, write transmission data to UA0BUF. To transmit the data consecutively, confirm the U0FUL flag of the UART0 status register (UA0STAT) becomes "0", then write the next transmitted data to the UA0BUF. Any value written to UA0BUF can be read.

In receive mode, since data received at termination of reception is stored in UA0BUF, read the contents of UA0BUF using the UART0 interrupt at termination of reception. At continuous reception, UA0BUF is updated whenever reception terminates. Any write to UA0BUF is disabled in receive mode.

The bits, which are not required when any of the 5- to 8-bit data length is selected, become invalid in transmit mode and are set to "0" in receive mode.

Note:

For operation in transmit mode, be sure to set the transmit mode (UA0MOD0 and UA0MOD1) before setting the transmitted data in UA0BUF.

13.2.3 UART0 Control Register (UA0CON)

Address: 0F291H
 Access: R/W
 Access size: 8-bit
 Initial value: 00H

| | | | | | | | | |
|---------------|-----|-----|-----|-----|-----|-----|-----|------|
| | 7 | 6 | 5 | 4 | 3 | 2 | 1 | 0 |
| UA0CON | — | — | — | — | — | — | — | U0EN |
| R/W | R/W | R/W | R/W | R/W | R/W | R/W | R/W | R/W |
| Initial value | 0 | 0 | 0 | 0 | 0 | 0 | 0 | 0 |

UA0CON is a special function register (SFR) to start/stop communication of the UART.

[Description of Bits]

- **U0EN** (bit 0)

The U0EN bit is used to specify the UART communication operation start. When U0EN is set to “1”, UART communication starts. In transmit mode, this bit is automatically set to “0” at termination of transmission. In receive mode, receive operation is continued. To terminate reception, set the bit to “0” by software.

| U0EN | Description |
|------|--------------------------------------|
| 0 | Stops communication. (Initial value) |
| 1 | Starts communication |

13.2.4 UART0 Mode Register 0 (UA0MOD0)

Address: 0F292H
 Access: R/W
 Access size: 8/16 bit
 Initial value: 00H

| | | | | | | | | |
|---------------|-----|-----|-------|--------|-----|-------|-------|------|
| | 7 | 6 | 5 | 4 | 3 | 2 | 1 | 0 |
| UA0MOD0 | — | — | U0RSS | U0RSEL | — | U0CK1 | U0CK0 | U0IO |
| R/W | R/W | R/W | R/W | R/W | R/W | R/W | R/W | R/W |
| Initial value | 0 | 0 | 0 | 0 | 0 | 0 | 0 | 0 |

UA0MOD0 is a special function register (SFR) to set the transfer mode of the UART.

[Description of Bits]

- **U0IO** (bit 0)
 The U0IO bit is used to select transmit or receive mode.

| U0IO | Description |
|------|-------------------------------|
| 0 | Transmit mode (initial value) |
| 1 | Receive mode |

- **U0CK1, U0CK0** (bits 2, 1)
 The U0CK1 and U0CK0 bits are used to select the clock to be input to the baud rate generator of the UART0.

| U0CK1 | U0CK0 | Description |
|-------|-------|-----------------------|
| 0 | 0 | LSCLK (initial value) |
| 0 | 1 | LSCLK × 2 |
| 1 | * | HSCLK |

- **U0RSEL** (bit 4)
 The U0RSEL bit is used to select the received data input pin for the UART0.

| U0RSEL | Description |
|--------|--------------------------------------|
| 0 | Selects the P02 pin. (Initial value) |
| 1 | Selects the P42 pin. |

- **U0RSS** (bit 5)
 U0RSS is the bit that selects the UART0 received data input sampling timing.

| U0RSS | Description |
|-------|--|
| 0 | Value set in the UA0BRTH and UA0BRTL registers/2 (initial value) |
| 1 | Value set in the UA0BRTH and UA0BRTL registers/2-1 |

Note:

- Always set the UA0MOD0 register while communication is stopped, and do not rewrite it during communication.
- When specifying LSCLK X 2 for the clock, enable the operation of the low-speed double clock by setting bit 2 (ENMLT) of the frequency control register 1 (FCON1) to “1”.
- When selecting the P42 pin as the received data input pin, it is necessary to configure settings for the Port 4 secondary functions. For the secondary functions of Port 4, see Chapter 17, “Port 4”.

13.2.5 UART0 Mode Register 1 (UA0MOD1)

Address: 0F293H
Access: R/W
Access size: 8/16 bit
Initial value: 00H

| | | | | | | | | |
|---------------|-----|-------|-------|-------|-------|-------|-------|-------|
| | 7 | 6 | 5 | 4 | 3 | 2 | 1 | 0 |
| UA0MOD1 | — | U0DIR | U0NEG | U0STP | U0PT1 | U0PT0 | U0LG1 | U0LG0 |
| R/W | R/W | R/W | R/W | R/W | R/W | R/W | R/W | R/W |
| Initial value | 0 | 0 | 0 | 0 | 0 | 0 | 0 | 0 |

UA0MOD1 is a special function register (SFR) to set the transfer mode of the UART.

[Description of Bits]

- **U0LG1, U0LG0** (bits 1, 0)

The U0LG1 and U0LG0 bits are used to specify the data length in the communication of the UART.

| U0LG1 | U0LG0 | Description |
|-------|-------|------------------------------|
| 0 | 0 | 8-bit length (initial value) |
| 0 | 1 | 7-bit length |
| 1 | 0 | 6-bit length |
| 1 | 1 | 5-bit length |

- **U0PT1, U0PT0** (bits 3, 2)

The U0PT1 and U0PT0 bits are used to select “even parity”, odd parity”, or “no parity” in the communication of the UART.

| U0PT1 | U0PT0 | Description |
|-------|-------|-----------------------------|
| 0 | 0 | Even parity (initial value) |
| 0 | 1 | Odd parity |
| 1 | * | No parity bit |

- **U0STP** (bit 4)

The U0STP bit is used to select the stop bit length in the communication of the UART.

| U0STP | Description |
|-------|----------------------------|
| 0 | 1 stop bit (initial value) |
| 1 | 2 stop bits |

- **U0NEG** (bit 5)
The U0NEG bit is used to select positive logic or negative logic in the communication of the UART.

| U0NEG | Description |
|--------------|--------------------------------|
| 0 | Positive logic (initial value) |
| 1 | Negative logic |

- **U0DIR** (bit 6)
The U0DIR bit is used to select LSB first or MSB first in the communication of the UART.

| U0DIR | Description |
|--------------|---------------------------|
| 0 | LSB first (initial value) |
| 1 | MSB first |

Note:

Always set the UA0MOD1 register while communication is stopped, and do not rewrite it during communication.

13.2.6 UART0 Baud Rate Registers L, H (UA0BRTL, UA0BRTH)

Address: 0F294H
Access: R/W
Access size: 8/16 bit
Initial value: 0FFH

| | 7 | 6 | 5 | 4 | 3 | 2 | 1 | 0 |
|---------------|-------|-------|-------|-------|-------|-------|-------|-------|
| UA0BRTL | U0BR7 | U0BR6 | U0BR5 | U0BR4 | U0BR3 | U0BR2 | U0BR1 | U0BR0 |
| R/W | R/W | R/W | R/W | R/W | R/W | R/W | R/W | R/W |
| Initial value | 1 | 1 | 1 | 1 | 1 | 1 | 1 | 1 |

Address: 0F295H
Access: R/W
Access size: 8-bit
Initial value: 0FH

| | 7 | 6 | 5 | 4 | 3 | 2 | 1 | 0 |
|---------------|-----|-----|-----|-----|--------|--------|-------|-------|
| UA0BRTH | — | — | — | — | U0BR11 | U0BR10 | U0BR9 | U0BR8 |
| R/W | R/W | R/W | R/W | R/W | R/W | R/W | R/W | R/W |
| Initial value | 0 | 0 | 0 | 0 | 1 | 1 | 1 | 1 |

UA0BRTL and UA0BRTH are special function registers (SFRs) to set the count value of the baud rate generator which generates baud rate clocks.

For the relationship between the count value of the baud rate generator and baud rate, see Section 13.3.2, “Baud Rate”.

Note:

Always set the UA0BRTL and UA0BRTH registers while communication is stopped, and do not rewrite them during communication.

13.2.7 UART0 Status Register (UA0STAT)

Address: 0F296H
 Access: R/W
 Access size: 8-bit
 Initial value: 00H

| | | | | | | | | |
|---------------|-----|-----|-----|-----|-------|-------|-------|-------|
| | 7 | 6 | 5 | 4 | 3 | 2 | 1 | 0 |
| UA0STAT | — | — | — | — | U0FUL | U0PER | U0OER | U0FER |
| R/W | R/W | R/W | R/W | R/W | R/W | R/W | R/W | R/W |
| Initial value | 0 | 0 | 0 | 0 | 0 | 0 | 0 | 0 |

UA0STAT is a special function register (SFR) to indicate the state of transmit or receive operation of the UART. When any data is written to UA0STAT, all the flags are initialized to “0”.

[Description of Bits]

- **U0FER** (bit 0)

The U0FER bit is used to indicate occurrence of a framing error of the UART. When an error occurs in the start or stop bit, the U0FER bit is set to “1”. This bit is updated each time reception is completed. The U0FER bit is fixed to “0” in transmit mode.

| U0FER | Description |
|-------|----------------------------------|
| 0 | No framing error (initial value) |
| 1 | With framing error |

- **U0OER** (bit 1)

The U0OER bit is used to indicate occurrence of an overrun error of the UART. If the received data in the transmit/receive buffer (UA0BUF) is received again before it is read, this bit is set to “1”. Even if reception is stopped by the U0EN bit and then reception is restarted, this bit is set to “1” if the previously received data is not read. Therefore, make sure that data is always read from the transmit/receive buffer even if the data is not required. The U0OER bit is fixed to “0” in transmit mode.

| U0OER | Description |
|-------|----------------------------------|
| 0 | No overrun error (initial value) |
| 1 | Overrun error |

- **U0PER** (bit 2)

The U0PER bit is used to indicate occurrence of a parity error of the UART. When the parity of the received data and the parity bit attached to the data do not coincide, this bit is set to “1”. U0PER is updated whenever data is received. The U0PER bit is fixed to “0” in transmit mode.

| U0PER | Description |
|-------|---------------------------------|
| 0 | No parity error (initial value) |
| 1 | Parity error |

- **U0FUL** (bit 3)

The U0FUL bit is used to indicate the state of the transmit/receive buffer of the UART.

When the transmitted data is written in UA0BUF in transmit mode, this bit is set to "1" and when this transmitted data is transferred to the shift register, this bit is set to "0". To transmit the data consecutively, confirm the U0FUL flag becomes "0", then write the next transmitted data to the UA0BUF.

The U0FUL bit is fixed to "0" in receive mode.

| U0FUL | Description |
|-------|--|
| 0 | There is no data in the transmit/receive buffer. (Initial value) |
| 1 | There is data in the transmit/receive buffer. |

13.3 Description of Operation

13.3.1 Transfer Data Format

In the transfer data format, one frame contains a start bit, a data bit, a parity bit, and a stop bit. In this format, 5 to 8 bits can be selected as data bit. For the parity bit, “with parity bit”, “without parity bit”, “even parity”, or “odd parity” can be selected. For the stop bit, “1 stop bit” or “2 stop bits” are available and for the transfer direction, “LSB first” or “MSB first” are available for selection. For serial input/output logic, positive logic or negative logic can be selected. All these options are set with the UART0 mode register (UA0MOD1).

Figure 13-2 and Figure 13-3 show the positive logic input/output format and negative logic input/output format, respectively.

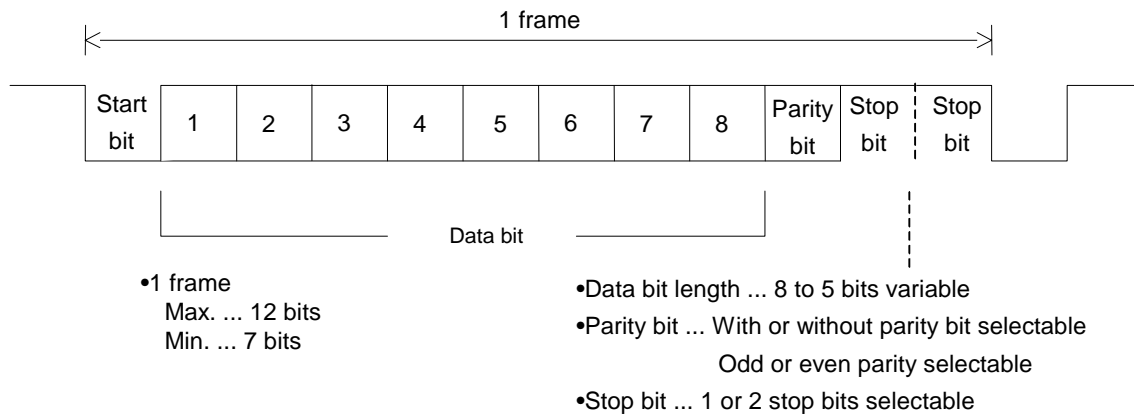

Figure 13-2 Positive Logic Input/Output Format

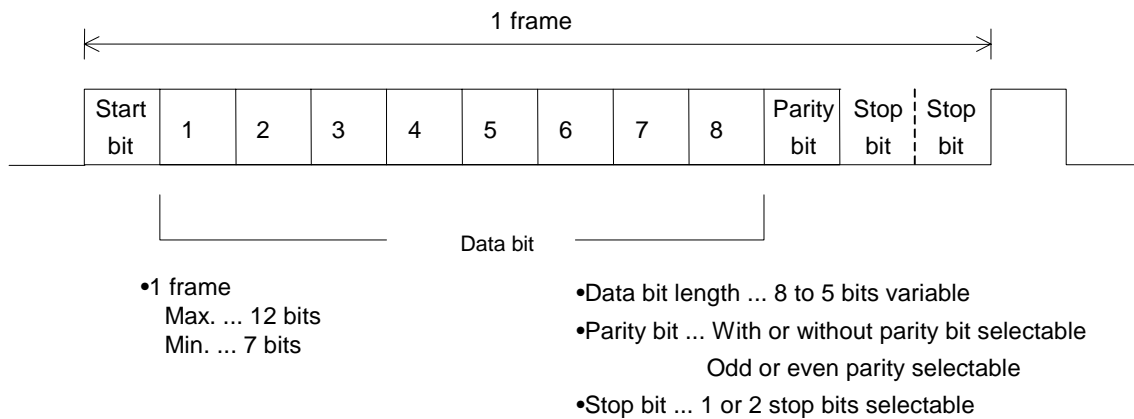

Figure 13-3 Negative Logic Input/Output Format

13.3.2 Baud rate

Baud rates are generated by the baud generator.

The baud rate generator generates a baud rate by counting the clock selected by the baud rate clock selection bits (U0CK1, U0CK0) of the UART0 mode register 0 (UA0MOD0). The count value of the baud rate generator can be set by writing it in the UART0 baud rate register H or L (UA0BRTH, UA0BRTL). The maximum count is 4096.

The setting values of UA0BRTH and UA0BRTL are expressed by the following equation.

$$UA0BRTH, L = \frac{\text{Clock frequency (Hz)}}{\text{Baud rate (bps)}} - 1$$

Table 13-2 lists the count values for typical baud rates.

Table 13-2 Count Values for Typical Baud Rates

| Baud rate | Baud rate generator Clock selection | | | Baud rate generator counter value | | | | Error [%] |
|-----------|--|-------|-------|-----------------------------------|--------------------------|---------|---------|--------------|
| | Baud rate Clock | U0CK1 | U0CK0 | Count value | Period of one bit | UA0BRTH | UA0BRTL | |
| 1200bps | 32.768kHz | 0 | 0 | 27 | Approximately 824us | 00H | 1AH | 1.1 |
| 2400bps | 32.768kHz | 0 | 0 | 14 | Approximately 427us | 00H | 0DH | -2.5 |
| | 65.536kHz | 0 | 1 | 27 | Approximately 412us | 00H | 1AH | 1.1 |
| 4800bps | 32.768kHz | 0 | 0 | 7 | Approximately 214us | 00H | 06H | -2.5 |
| | 65.536kHz | 0 | 1 | 14 | Approximately 214us | 00H | 0DH | -2.5 |
| | 500kHz | 1 | * | 104 | Approximately 208us | 00H | 67H | 0.2 |
| | 2MHz | | | 417 | Approximately 208.5us | 01H | A0H | -0.1 |
| 9600bps | 65.536kHz | 0 | 1 | 7 | Approximately 107us | 00H | 06H | -2.5 |
| | 500kHz | 1 | * | 52 | Approximately 104us | 00H | 33H | 0.2 |
| | 2MHz | | | 208 | Approximately 104us | 00H | CFH | 0.2 |
| 19200bps | 2MHz | 1 | * | 104 | Approximately 52us | 00H | 67H | 0.2 |
| 38400bps | 2MHz | 1 | * | 52 | Approximately 26us | 00H | 33H | 0.2 |

Note:

When using 65.536KHz (LSCLK X 2) for the baud rate generator input clock, enable the operation of the low-speed double clock by setting bit 2 (ENMLT) of the frequency control register 1 (FCON1) to "1".

When the baud rate clock generator input clock selection is set to 500kHz or 2MHz, an error of 500kHz±25% or 2MHz±25% may occur. To set the baud rate with accuracy, set the baud rate generator counter value by referring to the frequency measurement modes for Timers 2 and 3 (Sections 9.3.3).

Internal logic voltage (V_{DDL}) is changed by OSCM2 bit. V_{DDL} becomes Typ.1.2V when OSCM2 is set to "0" and 500kHz oscillation is selected. V_{DDL} becomes Typ.1.5V when OSCM2 is set to "1" and 2MHz oscillation is selected. Ensure to write this bit when the high-speed clock oscillator circuit stops oscillating (During FCON1 register's ENOSC bit is "0").

13.3.3 Transmitted Data Direction

Figure 13-4 shows the relationship between the transmit/receive buffer and the transmitted/received data.

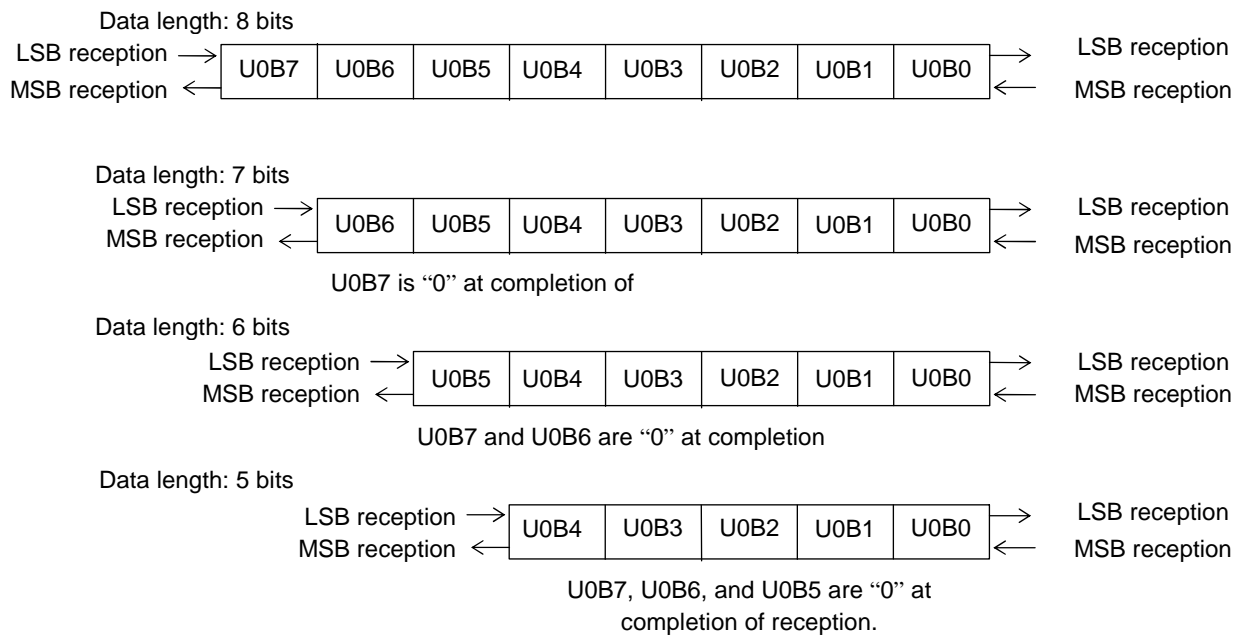

Figure 13-4 Relationship between Transmit/Receive Buffer and Transmitted/Received Data

Note:

When the TXD0 pin is set to serve the secondary function output in receive mode, "H" level is output from the TXD0 output.

13.3.4 Transmit Operation

Transmission is started by setting the U0IO bit of the UART0 mode register 0 (UA0MOD0) to “0” to select transmit mode and setting the U0EN bit of the UART0 control register (UA0CON) to “1”.

Figure 13-5 shows the operation timing for transmission.

When the U0EN bit is set to “1” (①), the baud rate generator generates an internal transfer clock of the baud rate set and starts transmission.

The start bit is output to the TXD0 pin by the falling edge of the internal transfer clock (②). Subsequently, the transmitted data, a parity bit, and a stop bit are output.

When the start bit is output (②), a UART0 interrupt is requested. In the UART0 interrupt routine, the next data to be transmitted is written to the transmit/receive buffer (UA0BUF).

When the next data to be transmitted is written to the transmit/receive buffer (UA0OBUF), the transmit buffer status flag (U0FUL) is set to “1” (③) and a UART0 interrupt is requested on the falling edge of the internal transfer clock (④) after transmission of the stop bit. If the UART0 interrupt routine is terminated without writing the next data to the transmit/receive buffer, the U0FUL bit is not set to “1” (⑤) and transmission continues up to the transmission of the stop bit, then the U0EN bit is reset to “0” and a UART0 interrupt is requested.

The valid period for the next transmit data to be written to the transmit/receive buffer is from the generation of an interrupt to the termination of stop bit transmission. (⑥)

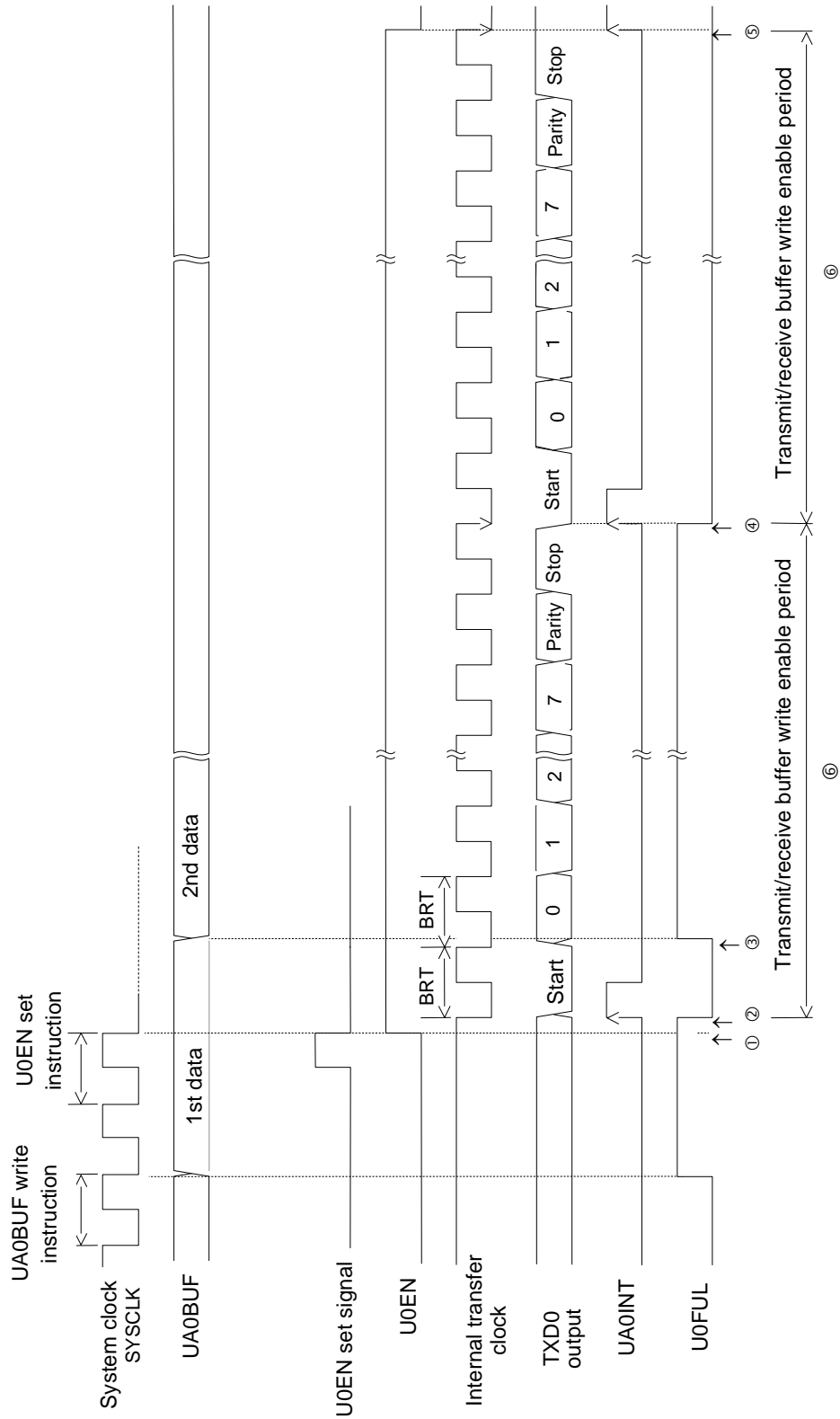

Figure 13-5 Operation Timing in Transmission

13.3.5 Receive Operation

Select the received data pin using the U0RSEL bit of the UART0 mode register 0 (UA0MOD0). Select the receive mode by setting the U0IO bit of the UART0 mode register 0 (UA0MOD0) to "1". Then, set the U0EN bit of the UART0 control register (UA0CON) to "1" to start receiving data.

Figure 13-6 shows the operation timing for reception.

When receive operation starts, the LSI checks the data sent to the input pin RXD0 and waits for the arrival of a start bit. When detecting a start bit (①), the LSI generates the internal transfer clock of the baud rate set with the start bit detect point as a reference and performs receive operation.

The shift register shifts in the data input to RXD on the rising edge of the internal transfer clock. The data and parity bit are shifted into the shift register and 5- to 8- bit received data is transferred to the transmit/receive buffer (UA0BUF) concurrently with the fall of the internal transfer clock of ③.

The LSI requests a UART0 interrupt on the rising edge of the internal transfer clock subsequent to the internal transfer clock by which the received data was fetched (④) and checks for a stop bit error and a parity bit error. When an error is detected, the LSI sets the corresponding bit of the UART0 status register (UA0STAT) to "1".

Parity error : S0PER = "1"
Overrun error : S0OER = "1"
Framing error : S0FER = "1"

As shown in Figure 13-6, the rise of the internal transfer clock is set so that it may fall into the middle of the bit interval of the received data.

Reception continues until the U0EN bit is reset to "0" by the program. When the U0EN bit is reset to "0" during reception, the received data may be destroyed. When the U0EN bit is reset to "0" during the "U0EN reset enable period" in Figure 13-6, the received data is protected.

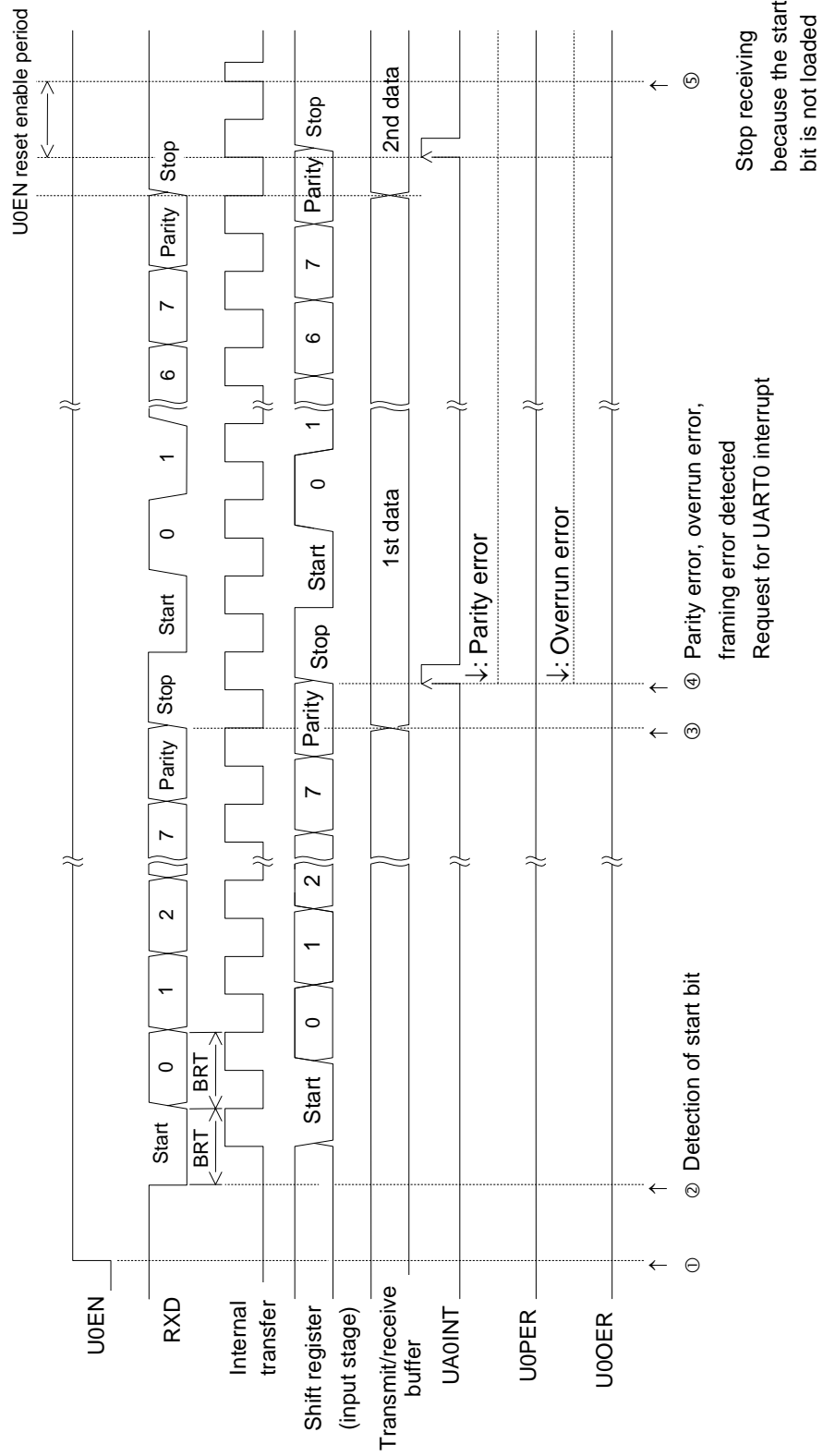

13.3.5.1 Detection of Start Bit

The Start bit is sampled using the baud rate generator clock (LSCLK, LSCLK x 2, HSCLK) selected by the U0CK1 and U0CK0 bits of the UARTn mode register 0 (UA0MOD0). Therefore, the start bit detection may be delayed for one cycle of the baud rate generate clock at the maximum.

Figure 13-7 shows the start bit detection timing.

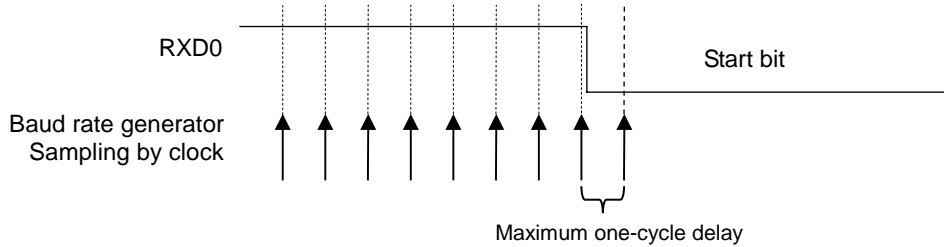

Figure 13-7 Start Bit Detection Timing (Positive Logic)

13.3.5.2 Sampling Timing

When the Start bit is detected, the received data that was input to the RXD0 is sampled almost at the center of the baud rate, then loaded to the shift register.

The loading sampling timing of this shift register can be adjusted for one clock of the baud rate generator clock, using the U0RSS bit of the UART0 mode register 0 (UA0MOD0).

Figure 13-8 shows the relationship between the U0RSS bit and the sampling timing.

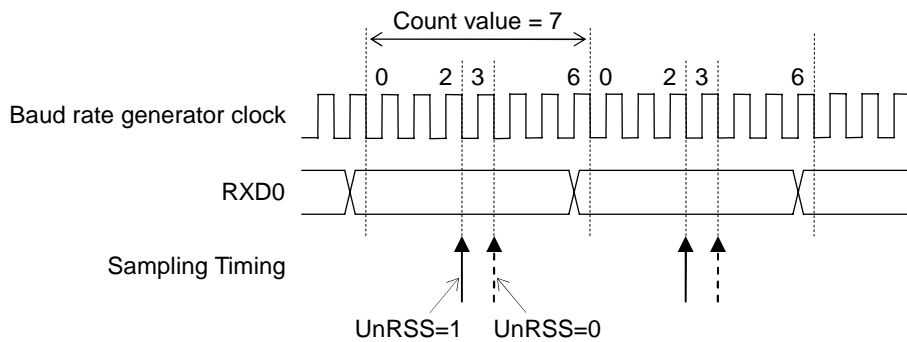

(1) When the baud rate generator count value is "7" (odd)

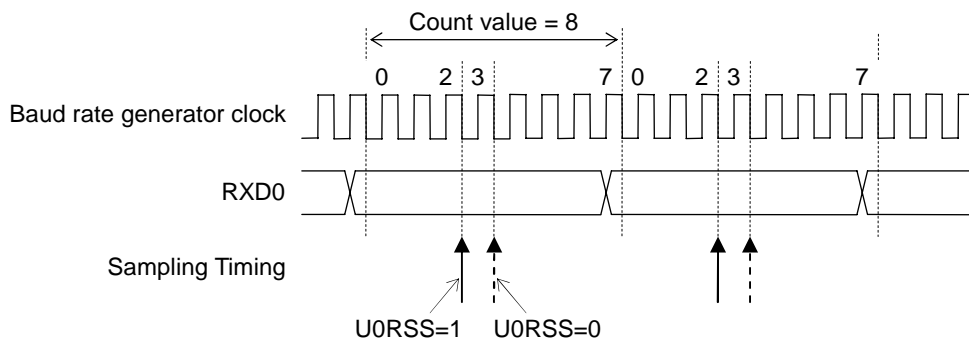

(2) When the baud rate generator count value is "8" (even)

Figure 13-8 Relationship between U0RSS Bit and Sampling Timing

13.3.5.3 Receive Margin

If there is an error between the sender baud rate and the baud rate generated by the baud rate generator of this LSI, the error accumulates until the last stop bit loading in one frame, decreasing the receive margin. This receive margin needs to be fully considered, particularly when the baud rate generator clock uses a lower frequency such as LSCLK and LSCLK x 2 to realize a higher bit rate (e.g., 4800bps, 9600bps).

Figure 13-9 shows the baud rate errors and receive margin waveforms.

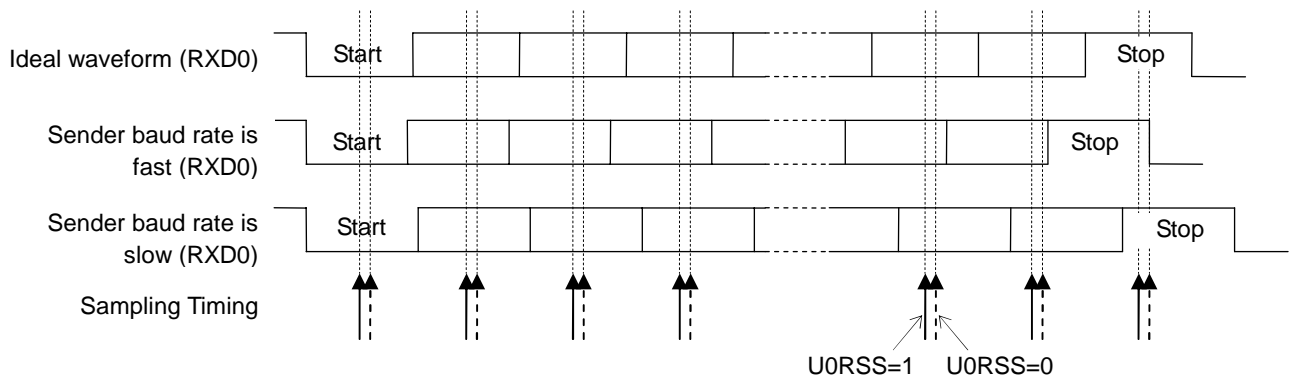

Figure 13-9 Baud Rate Error and Receive Margin

Note:

In system designing, ensure a sufficient receive margin considering the baud rate difference between sender and receiver, start bit detection delay, distortion in receive data, and influence of noise.

13.4.2 Functioning P43(TXD0) and P02(RXD0) as the UART

Set P43MD1 bit (bit3 of P4MOD1 register) to "0" and set P43MD0(bit3 of P4MOD0 register) to "1", for specifying the UART as the secondary function of P43.

| Register name | P4MOD1 register (Address: 0F225H) | | | | | | | |
|---------------|-----------------------------------|--------|--------|--------|---------------|--------|--------|--------|
| Bit | 7 | 6 | 5 | 4 | 3 | 2 | 1 | 0 |
| Bit name | P47MD1 | P46MD1 | P45MD1 | P44MD1 | P43MD1 | P42MD1 | P41MD1 | P40MD1 |
| Setting value | * | * | * | * | 0 | \$ | * | * |

| Register name | P4MOD0 register (Address: 0F224H) | | | | | | | |
|---------------|-----------------------------------|--------|--------|--------|---------------|--------|--------|--------|
| Bit | 7 | 6 | 5 | 4 | 3 | 2 | 1 | 0 |
| Bit name | P47MD0 | P46MD0 | P45MD0 | P44MD0 | P43MD0 | P42MD0 | P41MD0 | P40MD0 |
| Setting value | * | * | * | * | 1 | \$ | * | * |

Set the P43C1 bit (P4CON1 register's bit 3) to "1", the P43C0 bit (P4CON0 register's bit 3) to "1", and the P43DIR bit (P4DIR register's bit 3) to "0" for specifying the state mode of the P43 pin to CMOS output.

| Register name | P4CON1 register (Address: 0F223H) | | | | | | | |
|---------------|-----------------------------------|-------|-------|-------|--------------|-------|-------|-------|
| Bit | 7 | 6 | 5 | 4 | 3 | 2 | 1 | 0 |
| Bit name | P47C1 | P46C1 | P45C1 | P44C1 | P43C1 | P42C1 | P41C1 | P40C1 |
| Setting value | * | * | * | * | 1 | * | * | * |

| Register name | P4CON0 register (Address: 0F222H) | | | | | | | |
|---------------|-----------------------------------|-------|-------|-------|--------------|-------|-------|-------|
| Bit | 7 | 6 | 5 | 4 | 3 | 2 | 1 | 0 |
| Bit name | P47C0 | P46C0 | P45C0 | P44C0 | P43C0 | P42C0 | P41C0 | P40C0 |
| Setting value | * | * | * | * | 1 | * | * | * |

| Register name | P4DIR register (Address: 0F221H) | | | | | | | |
|---------------|----------------------------------|--------|--------|--------|---------------|--------|--------|--------|
| Bit | 7 | 6 | 5 | 4 | 3 | 2 | 1 | 0 |
| Bit name | P47DIR | P46DIR | P45DIR | P44DIR | P43DIR | P42DIR | P41DIR | P40DIR |
| Setting value | * | * | * | * | 0 | * | * | * |

The P43D bit (P4D register bit 3) data can either be "0" or "1" (not need to be set).

| Register name | P4D register (Address: 0F220H) | | | | | | | |
|---------------|--------------------------------|------|------|------|-------------|------|------|------|
| Bit | 7 | 6 | 5 | 4 | 3 | 2 | 1 | 0 |
| Bit name | P47D | P46D | P45D | P44D | P43D | P42D | P41D | P40D |
| Setting value | * | * | * | * | ** | * | * | * |

The P02 pin is an input-only pin and does not need input/output selection by the register. The set value (\$) is arbitrary for the P02C1 and P02C0 bits. Select an arbitrary input mode depending on the state of the external circuit to which the P02 pin is connected.

| Register name | P0CON1 register (Address: 0F207H) | | | | | | | |
|---------------|-----------------------------------|---|---|---|-------|--------------|-------|-------|
| Bit | 7 | 6 | 5 | 4 | 3 | 2 | 1 | 0 |
| Bit name | - | - | - | - | P03C1 | P02C1 | P01C1 | P00C1 |
| Setting value | - | - | - | - | * | \$ | * | * |

| Register name | P0CON0 register (Address: 0F206H) | | | | | | | |
|---------------|-----------------------------------|---|---|---|-------|--------------|-------|-------|
| Bit | 7 | 6 | 5 | 4 | 3 | 2 | 1 | 0 |
| Bit name | - | - | - | - | P03C0 | P02C0 | P01C0 | P00C0 |
| Setting value | - | - | - | - | * | \$ | * | * |

The P02D bit (P0D register bit 2) data can either be "0" or "1" (not need to be set).

| Register name | P0D register (Address: 0F204H) | | | | | | | |
|---------------|--------------------------------|---|---|---|------|-------------|------|------|
| Bit | 7 | 6 | 5 | 4 | 3 | 2 | 1 | 0 |
| Bit name | - | - | - | - | P03D | P02D | P01D | P00D |
| Setting value | - | - | - | - | * | ** | * | * |

- : Bit that does not exist

* : Bit not related to the UART function

** : Don't care \$: Optional

Note:

- The receive pin (RXD) is selected by U0RSEL bit (bit4 of UA0MOD0 register). The initial value "0" selects the P02 and the value "1" selects the P43.
- Even if the P42 pin is selected as RXD0 by the P42MD1, P42MD0, P42C1, P42C0, and P42IDR bits, the P02 pin will be selected as RXD0 when the U0RSEL bit of the UA0MOD0 register is "0".
- P02(Port 0) is an input-only port, does not have registers that can select data direction(input or output) or mode(primary or secondary function).

Chapter 14

Port 0

14. Port 0

14.1 Overview

This LSI includes the 5-bit, input-only Port 0 (P00 to P04).

14.1.1 Features

- All bits support a maskable interrupt function.
- Allows selection of interrupt disabled mode, falling-edge interrupt mode, rising-edge interrupt mode, or both-edge interrupt mode for each bit.
- Allows selection of with/without interrupt sampling for each bit. (Sampling frequency: T16KHZ)
- Allows selection of high-impedance input mode, input mode with a pull-down resistor, or input mode with a pull-up resistor for each bit.
- The P00 and P01 pins can be used as the trigger input pins of the capture circuit and the P02 pin can be used as the RXD0 input pin of UART0.
- The P04 pin can be used as an external clock (T02P0CK) input pin for the timers and the PWM.

14.1.2 Configuration

Figure 14-1 shows the configuration of Port 0.

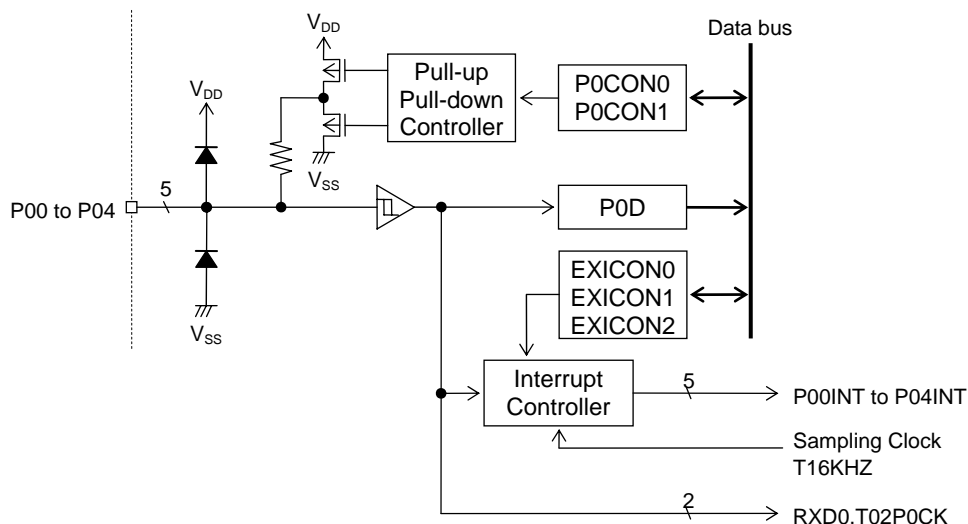

P0D : Port 0 data register
P0CON0: Port 0 control register 0
P0CON1: Port 0 control register 1
EXICON0 : External interrupt control register 0
EXICON1 : External interrupt control register 1
EXICON2 : External interrupt control register 2

Figure 14-1 Configuration of Port 0

14.1.3 List of Pins

| Pin name | I/O | Function |
|----------------------|-----|--|
| P00/EXI0/CAP0 | I | Input port, External 0 interrupt, Capture 0 trigger signal input |
| P01/EXI1/CAP1 | I | Input port, External 1 interrupt, Capture 1 trigger signal input |
| P02/EXI2/RXD0 | I | Input port, External 2 interrupt, UART0 data input (RXD0) |
| P03/EXI3 | I | Input port, External 3 interrupt |
| P04/EXI4/ T02P0CK | I | Input port, external 4 interrupt, external clock input (T02P0CK) to Timer 0, Timer 2, and PWM0 |

14.2 Description of Registers

14.2.1 List of Registers

| Address | Name | Symbol (Byte) | Symbol (Word) | R/W | Size | Initial value |
|---------|---------------------------------------|---------------|---------------|-----|------|----------------------|
| 0F204H | Port 0 data register | P0D | — | R | 8 | Depends on pin state |
| 0F206H | Port 0 control register 0 | P0CON0 | P0CON | R/W | 8/16 | 00H |
| 0F207H | Port 0 control register 1 | P0CON1 | | R/W | 8 | 00H |
| 0F020H | External interrupt control register 0 | EXICON0 | — | R/W | 8 | 00H |
| 0F021H | External interrupt control register 1 | EXICON1 | — | R/W | 8 | 00H |
| 0F022H | External interrupt control register 2 | EXICON2 | — | R/W | 8 | 00H |

14.2.2 Port 0 Data Register (P0D)

Address: 0F204H

Access: R

Access size: 8-bit

Initial value: Depends on pin state

| | | | | | | | | |
|---------------|---|---|---|------|------|------|------|------|
| | 7 | 6 | 5 | 4 | 3 | 2 | 1 | 0 |
| P0D | — | — | — | P04D | P03D | P02D | P01D | P00D |
| R | R | R | R | R | R | R | R | R |
| Initial value | 0 | 0 | 0 | x | x | x | x | x |

P0D is a special function register (SFR) to only read the pin level of Port 0.

[Description of Bits]

- **P04D to P00D** (bits 4 to 0)

The P04D to P00D bits are used to read the pin level of Port 0.

| P04D | Description |
|------|--------------------------|
| 0 | P04 pin input: "L" level |
| 1 | P04 pin input: "H" level |

| P03D | Description |
|------|--------------------------|
| 0 | P03 pin input: "L" level |
| 1 | P03 pin input: "H" level |

| P02D | Description |
|------|--------------------------|
| 0 | P02 pin input: "L" level |
| 1 | P02 pin input: "H" level |

| P01D | Description |
|------|--------------------------|
| 0 | P01 pin input: "L" level |
| 1 | P01 pin input: "H" level |

| P00D | Description |
|------|--------------------------|
| 0 | P00 pin input: "L" level |
| 1 | P00 pin input: "H" level |

14.2.3 Port 0 Control Registers 0, 1 (P0CON0, P0CON1)

Address: 0F206H
 Access: R/W
 Access size: 8/16 bit
 Initial value: 00H

| | | | | | | | | |
|---------------|-----|-----|-----|-------|-------|-------|-------|-------|
| | 7 | 6 | 5 | 4 | 3 | 2 | 1 | 0 |
| P0CON0 | — | — | — | P04C0 | P03C0 | P02C0 | P01C0 | P00C0 |
| R/W | R/W | R/W | R/W | R/W | R/W | R/W | R/W | R/W |
| Initial value | 0 | 0 | 0 | 0 | 0 | 0 | 0 | 0 |

Address: 0F207H
 Access: R/W
 Access size: 8-bit
 Initial value: 00H

| | | | | | | | | |
|---------------|-----|-----|-----|-------|-------|-------|-------|-------|
| | 7 | 6 | 5 | 4 | 3 | 2 | 1 | 0 |
| P0CON1 | — | — | — | P04C1 | P03C1 | P02C1 | P01C1 | P00C1 |
| R/W | R/W | R/W | R/W | R/W | R/W | R/W | R/W | R/W |
| Initial value | 0 | 0 | 0 | 0 | 0 | 0 | 0 | 0 |

P0CON0 and P0CON1 are special function registers (SFRs) to select the input mode of Port 0.

[Description of Bits]

- P04C0 to P00C0, P04C1 to P00C1 (bits 4 to 0)
 The P04C0 to P00C0 bits and the P04C1 to P00C1 bits are used to select high-impedance input mode, input mode with a pull-down resistor, or input mode with a pull-up resistor. The P0nC0 bit and the P0nC1 bit determine the input mode of P0n (Example: When P02C0 = "0" and P02C1 = "1", P02 is in input mode with a pull-up resistor).

| P04C1-P00C1 | P04C0-P00C0 | Description |
|-------------|-------------|---|
| 0 | 0 | High-impedance input mode (initial value) |
| 0 | 1 | Input mode with a pull-down resistor |
| 1 | 0 | Input mode with a pull-up resistor |
| 1 | 1 | High-impedance input mode |

14.2.4 External Interrupt Control Registers 0, 1 (EXICON0, EXICON1)

Address: 0F020H
Access: R/W
Access size: 8-bit
Initial value: 00H

| | | | | | | | | |
|---------------|-----|-----|-----|-------|-------|-------|-------|-------|
| | 7 | 6 | 5 | 4 | 3 | 2 | 1 | 0 |
| EXICON0 | — | — | — | P04E0 | P03E0 | P02E0 | P01E0 | P00E0 |
| R/W | R/W | R/W | R/W | R/W | R/W | R/W | R/W | R/W |
| Initial value | 0 | 0 | 0 | 0 | 0 | 0 | 0 | 0 |

Address: 0F021H
Access: R/W
Access size: 8-bit
Initial value: 00H

| | | | | | | | | |
|---------------|-----|-----|-----|-------|-------|-------|-------|-------|
| | 7 | 6 | 5 | 4 | 3 | 2 | 1 | 0 |
| EXICON1 | — | — | — | P04E1 | P03E1 | P02E1 | P01E1 | P00E1 |
| R/W | R/W | R/W | R/W | R/W | R/W | R/W | R/W | R/W |
| Initial value | 0 | 0 | 0 | 0 | 0 | 0 | 0 | 0 |

EXICON0 and EXICON1 are special function registers (SFRs) to select an interrupt edge of Port 0.

[Description of Bits]

- **P04E0 to P00E0, P04E1 to P00E1** (bits 4 to 0)

The P04E0 to P00E0 bits and the P04E1 to P00E1 bits are used to select interrupt disabled mode, falling-edge interrupt mode, rising-edge interrupt mode, or both-edge interrupt mode. The P0nE0 bit and the P0nE1 bit determine the interrupt mode of P0n (Example: When P02E0 = “0” and P02E1 = “1”, P02 is in rising-edge interrupt mode).

| P04E1-P00E1 | P04E0-P00E0 | Description |
|-------------|-------------|------------------------------------|
| 0 | 0 | Interrupt disabled (initial value) |
| 0 | 1 | Falling-edge interrupt mode |
| 1 | 0 | Rising-edge interrupt mode |
| 1 | 1 | Both-edge interrupt mode |

14.2.5 External Interrupt Control Register 2 (EXICON2)

Address: 0F022H
 Access: R/W
 Access size: 8-bit
 Initial value: 00H

| | | | | | | | | |
|---------------|-----|-----|-----|-------|-------|-------|-------|-------|
| | 7 | 6 | 5 | 4 | 3 | 2 | 1 | 0 |
| EXICON2 | — | — | — | P04SM | P03SM | P02SM | P01SM | P00SM |
| R/W | R/W | R/W | R/W | R/W | R/W | R/W | R/W | R/W |
| Initial value | 0 | 0 | 0 | 0 | 0 | 0 | 0 | 0 |

EXICON2 is a special function register (SFR) to select whether the Port 0 interrupt is with sampling or without sampling.

[Description of Bits]

- **P04SM to P00SM** (bits 4 to 0)

The P04SM to P00SM bits are used to select detection of signal edge for Port 0 interrupts with or without sampling. The sampling clock is T16KHZ of the low-speed time base counter (LTBC).

| P04SM | Description |
|-------|---|
| 0 | Detects the input signal edge for a P04 interrupt without sampling (initial value). |
| 1 | Detects the input signal edge for a P04 interrupt with sampling. |

| P03SM | Description |
|-------|---|
| 0 | Detects the input signal edge for a P03 interrupt without sampling (initial value). |
| 1 | Detects the input signal edge for a P03 interrupt with sampling. |

| P02SM | Description |
|-------|---|
| 0 | Detects the input signal edge for a P02 interrupt without sampling (initial value). |
| 1 | Detects the input signal edge for a P02 interrupt with sampling. |

| P01SM | Description |
|-------|---|
| 0 | Detects the input signal edge for a P01 interrupt without sampling (initial value). |
| 1 | Detects the input signal edge for a P01 interrupt with sampling. |

| P00SM | Description |
|-------|---|
| 0 | Detects the input signal edge for a P00 interrupt without sampling (initial value). |
| 1 | Detects the input signal edge for a P00 interrupt with sampling. |

Note:

In STOP mode, since the 16 kHz sampling clock stops, no sampling is performed regardless of the values set in P00SM to P04SM.

14.3 Description of Operation

For each pin of Port 0, the setting of the Port 0 control registers 0 and 1 (P0CON0 and P0CON1) allows selection of high-impedance input mode, input mode with a pull-down resistor, or input mode with a pull-up resistor.

High-impedance input mode is selected at system reset.

The pin level of Port 0 can be read by reading the Port 0 data register (P0D).

14.3.1 External Interrupt / Secondary Function

The Port 0 pins (P00, P01, P02, P03, P04) can be used for P00 to P04 interrupts (P00INT to P04INT). The P00 to P04 interrupts are maskable and interrupt enable or disable can be selected. For interrupts, see Chapter 5, "Interrupt."

The P00 and P01 pins can be used as the trigger input to the capture circuit, the P02 pin as the RXD0 input to the UART0, and the P04 pin as the external clock input to the timers and the PWM.

For the capture function, see Chapter 8, "Capture." For the UART function, see Chapter 13, "UART." For the timer function, see Chapter 9, "Timer." For the PWM function, see Chapter 10, "PWM."

14.3.2 Interrupt Request

When an interrupt edge selected with the external interrupt control register 0, 1, or 2 (EXICON0, EXICON1, or EXICON2) occurs at a Port 0 pin, any of the maskable P00 to P04 interrupts (P00INT to P04INT) occurs.

Figure 14-2 shows the P00 to P04 interrupt generation timing in rising-edge interrupt mode, in falling-edge interrupt mode, and in both-edge interrupt mode without sampling and the P00 to P04 interrupt generation timing in rising-edge interrupt mode with sampling.

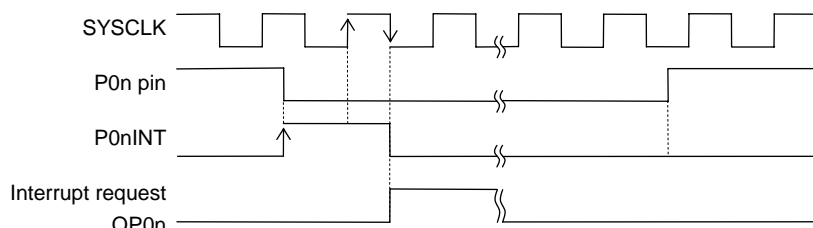

(a) When Falling-Edge Interrupt Mode without Sampling is Selected

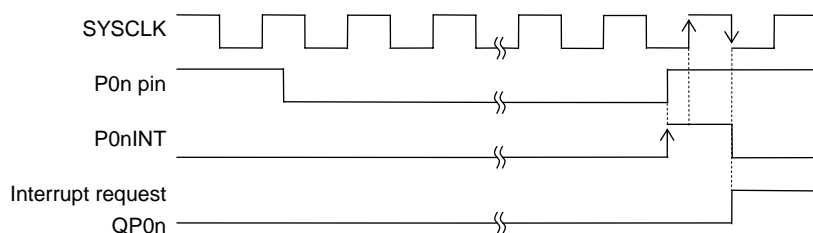

(b) When Rising-Edge Interrupt Mode without Sampling is Selected

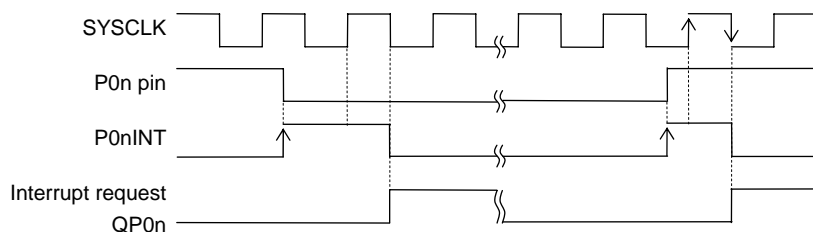

(c) When Both-Edge Interrupt Mode without Sampling is Selected

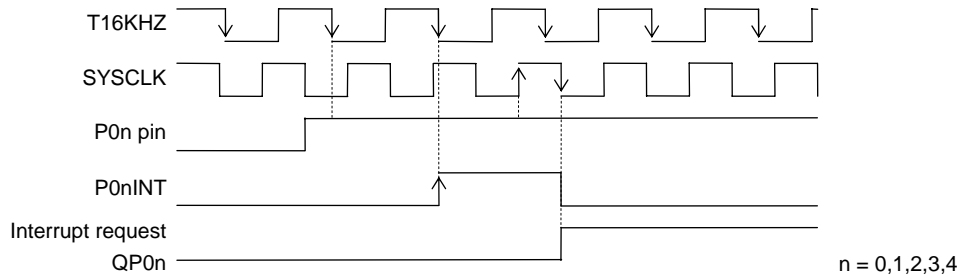

(d) When Rising-Edge Interrupt Mode with Sampling is Selected

Figure 14-2 P00 to P04 Interrupts Generation Timing

Chapter 15

Port 2

15. Port 2

15.1 Overview

This LSI includes 4-bit Port 2 (P20 to P22, and P24) dedicated to output. Port 2 can output low-speed clock (LSCLK), high-speed clock (OUTCLK), melody, and PWM waveform as a secondary function. For the clock output, see Chapter 6, "Clock Generation Circuit." For the Melody 0 (MD0) output, see Chapter 20, "Melody Driver." For the PWM (PWM0) output, see Chapter 10, "PWM."

15.1.1 Features

- Allows direct LED drive.
- Allows selection of high-impedance output mode, P-channel open drain output mode, N-channel open drain output mode, or CMOS output mode for each bit.
- Allows output of low-speed clock (LSCLK), high-speed clock (OUTCLK), Melody 0 (MD0), and PMW waveform (PWM0) as a secondary function.

15.1.2 Configuration

Figure 15-1 shows the configuration of Port 2.

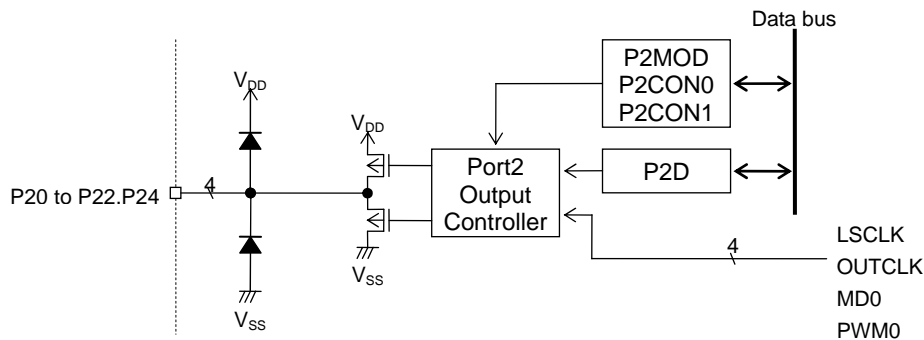

P2D : Port 2 data register
P2CON0: Port 2 control register 0
P2CON1: Port 2 control register 1
P2MOD : Port 2 mode register

Figure 15-1 Configuration of Port 2

15.1.3 List of Pins

| Pin name | I/O | Primary function | Secondary function |
|-----------------|-----|------------------|----------------------------------|
| P20/LED0/LSCLK | O | Output port | Low-speed clock output (LSCLK) |
| P21/LED1/OUTCLK | O | Output port | High-speed clock output (OUTCLK) |
| P22/LED2/MD0 | O | Output port | Melody 0 output (MD0) |
| P24/LED4/PWM0 | O | Output port | PWM0 output (PWM0) |

15.2 Description of Registers

15.2.1 List of Registers

| Address | Name | Symbol (Byte) | Symbol (Word) | R/W | Size | Initial value |
|---------|---------------------------|---------------|---------------|-----|------|---------------|
| 0F210H | Port 2 data register | P2D | — | R/W | 8 | 00H |
| 0F212H | Port 2 control register 0 | P2CON0 | P2CON | R/W | 8/16 | 00H |
| 0F213H | Port 2 control register 1 | P2CON1 | | R/W | 8 | 00H |
| 0F214H | Port 2 mode register | P2MOD | — | R/W | 8 | 00H |

15.2.2 Port 2 Data Register (P2D)

Address: 0F210H
Access: R/W
Access size: 8-bit
Initial value: 00H

| | | | | | | | | |
|---------------|-----|-----|-----|------|-----|------|------|------|
| | 7 | 6 | 5 | 4 | 3 | 2 | 1 | 0 |
| P2D | — | — | — | P24D | — | P22D | P21D | P20D |
| R/W | R/W | R/W | R/W | R/W | R/W | R/W | R/W | R/W |
| Initial value | 0 | 0 | 0 | 0 | 0 | 0 | 0 | 0 |

P2D is a special function register (SFR) to set the output value of the Port 2. The value of this register is output to Port 2. The value written to P2D is readable.

[Description of Bits]

- **P24D** (bits 4 to 0)

The P24D and P22D to P20D bits are used to set the output value of the Port 2 pin.

| P24D | Description |
|------|----------------------------------|
| 0 | Output level of the P24 pin: "L" |
| 1 | Output level of the P24 pin: "H" |

| P22D | Description |
|------|----------------------------------|
| 0 | Output level of the P22 pin: "L" |
| 1 | Output level of the P22 pin: "H" |

| P21D | Description |
|------|----------------------------------|
| 0 | Output level of the P21 pin: "L" |
| 1 | Output level of the P21 pin: "H" |

| P20D | Description |
|------|----------------------------------|
| 0 | Output level of the P20 pin: "L" |
| 1 | Output level of the P20 pin: "H" |

15.2.3 Port 2 Control Registers 0, 1 (P2CON0, P2CON1)

Address: 0F212H
 Access: R/W
 Access size: 8/16 bit
 Initial value: 00H

| | | | | | | | | |
|---------------|-----|-----|-----|-------|-----|-------|-------|-------|
| | 7 | 6 | 5 | 4 | 3 | 2 | 1 | 0 |
| P2CON0 | — | — | — | P24C0 | — | P22C0 | P21C0 | P20C0 |
| R/W | R/W | R/W | R/W | R/W | R/W | R/W | R/W | R/W |
| Initial value | 0 | 0 | 0 | 0 | 0 | 0 | 0 | 0 |

Address: 0F213H
 Access: R/W
 Access size: 8-bit
 Initial value: 00H

| | | | | | | | | |
|---------------|-----|-----|-----|-------|-----|-------|-------|-------|
| | 7 | 6 | 5 | 4 | 3 | 2 | 1 | 0 |
| P2CON1 | — | — | — | P24C1 | — | P22C1 | P21C1 | P20C1 |
| R/W | R/W | R/W | R/W | R/W | R/W | R/W | R/W | R/W |
| Initial value | 0 | 0 | 0 | 0 | 0 | 0 | 0 | 0 |

P2CON0 and P2CON1 are special function registers (SFRs) to select the output state of the output pin Port 2.

[Description of Bits]

- **P24C0, P22C0 to P20C0, P24C1, P22C1 to P20C1** (bits 4 and 2 to 0)
 The P24C0, P22C0 to P20C0, P24C1, and P22C1 to P20C1 bits are used to select high-impedance output mode, P-channel open drain output mode, N-channel open drain output mode, or CMOS output mode.
 To directly drive LEDs, select N-channel open drain output mode.

| P24C1 | P24C0 | Description |
|-------|-------|--|
| 0 | 0 | P24 pin: In high-impedance output mode (initial value) |
| 0 | 1 | P24 pin: In P-channel open drain output mode |
| 1 | 0 | P24 pin: In N-channel open drain output mode |
| 1 | 1 | P24 pin: In CMOS output mode |

| P22C1 | P22C0 | Description |
|-------|-------|--|
| 0 | 0 | P22 pin: In high-impedance output mode (initial value) |
| 0 | 1 | P22 pin: In P-channel open drain output mode |
| 1 | 0 | P22 pin: In N-channel open drain output mode |
| 1 | 1 | P22 pin: In CMOS output mode |

| P21C1 | P21C0 | Description |
|-------|-------|--|
| 0 | 0 | P21 pin: In high-impedance output mode (initial value) |
| 0 | 1 | P21 pin: In P-channel open drain output mode |
| 1 | 0 | P21 pin: In N-channel open drain output mode |
| 1 | 1 | P21 pin: In CMOS output mode |

| P20C1 | P20C0 | Description |
|-------|-------|--|
| 0 | 0 | P20 pin: In high-impedance output mode (initial value) |
| 0 | 1 | P20 pin: In P-channel open drain output mode |
| 1 | 0 | P20 pin: In N-channel open drain output mode |
| 1 | 1 | P20 pin: In CMOS output mode |

15.2.4 Port 2 Mode Register (P2MOD)

Address: 0F214H
Access: R/W
Access size: 8-bit
Initial value: 00H

| | | | | | | | | |
|---------------|-----|-----|-----|-------|-----|-------|-------|-------|
| | 7 | 6 | 5 | 4 | 3 | 2 | 1 | 0 |
| P2MOD | — | — | — | P24MD | — | P22MD | P21MD | P20MD |
| R/W | R/W | R/W | R/W | R/W | R/W | R/W | R/W | R/W |
| Initial value | 0 | 0 | 0 | 0 | 0 | 0 | 0 | 0 |

P2MOD is a special function register (SFR) to select the primary function or the secondary function of Port 2.

[Description of Bits]

- **P24MD** (bit 4)

The P24MD bit is used to select the primary function or the secondary function of the P24 pin.

| P24MD | Description |
|-------|--|
| 0 | General-purpose output port function (initial value) |
| 1 | PWM0 output function |

- **P22MD** (bit 2)

The P22MD bit is used to select the primary function or the secondary function of the P22 pin.

| P22MD | Description |
|-------|--|
| 0 | General-purpose output port function (initial value) |
| 1 | Melody 0 (MD0) output function |

- **P21MD** (bit 1)

The P21MD bit is used to select the primary function or the secondary function of the P21 pin.

| P21MD | Description |
|-------|--|
| 0 | General-purpose output port function (initial value) |
| 1 | High-speed clock (OUTCLK) output function |

- **P20MD** (bit 0)

The P20MD bit is used to select the primary function or the secondary function of the P20 pin.

| P20MD | Description |
|-------|--|
| 0 | General-purpose output port function (initial value) |
| 1 | Low-speed clock (LSCLK) output function |

Note:

- P2 (Port 2) is an output-only pin and does not have the register to select the data direction(input or output).
- The output characteristics of the P2 pins (P20, P21, P22, and P24) are VOL1 and VOH1 (described in "Appendix C Electrical Characteristics") when each bit (P20MD, P21MD, P22MD, and P24MD) of the corresponding P2MOD register is "1" (melody/buzzer is selected as the secondary function) and are VOL2 and VOH2 when each bit is "0".

15.3 Description of Operation

15.3.1 Output Port Function

For each pin of Port 2, any one of high-impedance output mode, P-channel open drain output mode, N-channel open drain output mode, and CMOS output mode can be selected by setting the Port 2 control registers 0 and 1 (P2CON0 and P2CON1). At a system reset, high-impedance output mode is selected as the initial state.

Depending of the value set in the Port 2 data register (P2D), a “L” level or “H” level signal is output to each pin of Port 2.

15.3.2 Secondary Function

Low-speed clock (LSCLK) output, High-speed clock (OUTCLK) output, melody 0 (MD0) output, and PWM 0 output are assigned to Port 2 as a secondary function. The secondary function can be used by setting the P24MD and P22MD to P20MD bits of the Port 2 mode register (P2MOD) to “1”.

Chapter 16

Port 3

16. Port 3

16.1 Overview

This LSI includes Port 3 (P30 to P35), which is a 6-bit input/output port.

Furthermore, the oscillation pins (IN0, CS0, RS0, RT0, RCT0, and RCM) for the RC-ADC (Channel 0) are provided as the secondary function mode.

For the RC-ADC, see Chapter 21, “RC Oscillation Type A/D Converter”.

16.1.1 Features

- Allows selection of high-impedance output, P-channel open drain output, N-channel open drain output, or CMOS output for each bit in output mode.
- Allows selection of high-impedance input, input with a pull-down resistor, or input with a pull-up resistor for each bit in input mode.
- The oscillation pins (IN0, CS0, RS0, RT0, RCT0, and RCM) for the RC-ADC (Channel 0) are available as the secondary function mode.

16.1.2 Configuration

Figure 16-1 shows the configuration of Port 3.

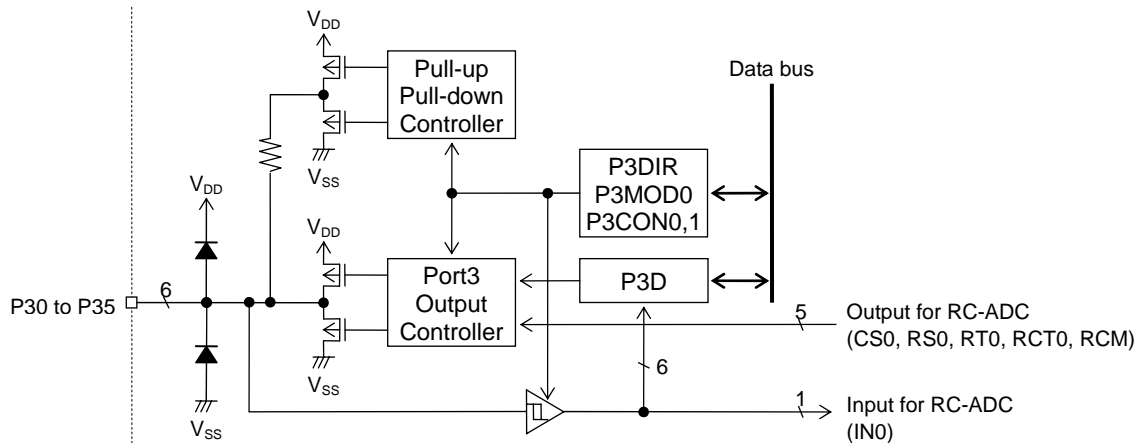

P3D : Port 3 data register
P3DIR : Port 3 direction register
P3CON0: Port 3 control register 0
P3CON1: Port 3 control register 1
P3MOD0 : Port 3 mode register 0

Figure 16-1 Configuration of Port 3

16.1.3 List of Pins

| Pin name | I/O | Primary function | Secondary function |
|----------|-----|-------------------|--|
| P30/IN0 | I/O | Input/output port | Oscillation waveform input pin for RC-ADC0 |
| P31/CS0 | I/O | Input/output port | Reference capacitor connection pin for RC-ADC0 |
| P32/RS0 | I/O | Input/output port | Reference resistor connection pin for RC-ADC0 |
| P33/RT0 | I/O | Input/output port | Resistor sensor connection pin for measurement for RC-ADC0 |
| P34/RCT0 | I/O | Input/output port | Resistor/capacitor sensor connection pin for measurement for RC-ADC0 |
| P35/RCM | I/O | Input/output port | RC oscillation monitor pin for RC-ADC0 |

16.2 Description of Registers

16.2.1 List of Registers

| Address | Name | Symbol (Byte) | Symbol (Word) | R/W | Size | Initial value |
|---------|---------------------------|---------------|---------------|-----|------|---------------|
| 0F218H | Port 3 data register | P3D | — | R/W | 8 | 00H |
| 0F219H | Port 3 direction register | P3DIR | — | R/W | 8 | 00H |
| 0F21AH | Port 3 control register 0 | P3CON0 | P3CON | R/W | 8/16 | 00H |
| 0F21BH | Port 3 control register 1 | P3CON1 | | R/W | 8 | 00H |
| 0F21CH | Port 3 mode register 0 | P3MOD0 | — | R/W | 8 | 00H |

16.2.2 Port 3 Data Register (P3D)

Address: 0F218H
Access: R/W
Access size: 8-bit
Initial value: 00H

| | | | | | | | | |
|---------------|-----|-----|------|------|------|------|------|------|
| | 7 | 6 | 5 | 4 | 3 | 2 | 1 | 0 |
| P3D | — | — | P35D | P34D | P33D | P32D | P31D | P30D |
| R/W | R/W | R/W | R/W | R/W | R/W | R/W | R/W | R/W |
| Initial value | 0 | 0 | 0 | 0 | 0 | 0 | 0 | 0 |

P3D is a special function register (SFR) to set the value to be output to the Port 3 pin or to read the input level of the Port 3. In output mode, the value of this register is output to the Port 3 pin. The value written to P3D is readable. In input mode, the input level of the Port 3 pin is read when P3D is read. Output mode or input mode is selected by using the port direction register (P3DIR) described later.

[Description of Bits]

- **P35D to P30D** (bits 5 to 0)

The P35D to P30D bits are used to set the output value of the Port 3 pin in output mode and to read the pin level of the Port 3 pin in input mode.

| P35D | Description |
|------|---|
| 0 | Output or input level of the P35 pin: "L" |
| 1 | Output or input level of the P35 pin: "H" |

| P34D | Description |
|------|---|
| 0 | Output or input level of the P34 pin: "L" |
| 1 | Output or input level of the P34 pin: "H" |

| P33D | Description |
|------|---|
| 0 | Output or input level of the P33 pin: "L" |
| 1 | Output or input level of the P33 pin: "H" |

| P32D | Description |
|------|---|
| 0 | Output or input level of the P32 pin: "L" |
| 1 | Output or input level of the P32 pin: "H" |

| P31D | Description |
|------|---|
| 0 | Output or input level of the P31 pin: "L" |
| 1 | Output or input level of the P31 pin: "H" |

| P30D | Description |
|------|---|
| 0 | Output or input level of the P30 pin: "L" |
| 1 | Output or input level of the P30 pin: "H" |

16.2.3 Port 3 Direction Register (P3DIR)

Address: 0F219H
 Access: R/W
 Access size: 8-bit
 Initial value: 00H

| | | | | | | | | |
|---------------|-----|-----|--------|--------|--------|--------|--------|--------|
| | 7 | 6 | 5 | 4 | 3 | 2 | 1 | 0 |
| P3DIR | — | — | P35DIR | P34DIR | P33DIR | P32DIR | P31DIR | P30DIR |
| R/W | R/W | R/W | R/W | R/W | R/W | R/W | R/W | R/W |
| Initial value | 0 | 0 | 0 | 0 | 0 | 0 | 0 | 0 |

P3DIR is a special function register (SFR) to select the input/output mode of Port 3.

[Description of Bits]

- **P35DIR to P30DIR** (bits 5 to 0)
 P35DIR to P30DIR are the bits for setting the input/output direction of the Port 3 pins.

| P35DIR | Description |
|--------|---------------------------------|
| 0 | P35 pin: Output (initial value) |
| 1 | P35 pin: Input |

| P34DIR | Description |
|--------|---------------------------------|
| 0 | P34 pin: Output (initial value) |
| 1 | P34 pin: Input |

| P33DIR | Description |
|--------|---------------------------------|
| 0 | P33 pin: Output (initial value) |
| 1 | P33 pin: Input |

| P32DIR | Description |
|--------|---------------------------------|
| 0 | P32 pin: Output (initial value) |
| 1 | P32 pin: Input |

| P31DIR | Description |
|--------|---------------------------------|
| 0 | P31 pin: Output (initial value) |
| 1 | P31 pin: Input |

| P30DIR | Description |
|--------|---------------------------------|
| 0 | P30 pin: Output (initial value) |
| 1 | P30 pin: Input |

16.2.4 Port 3 Control Registers 0, 1 (P3CON0, P3CON1)

Address: 0F21AH
Access: R/W
Access size: 8/16 bit
Initial value: 00H

| | | | | | | | | |
|---------------|-----|-----|-------|-------|-------|-------|-------|-------|
| | 7 | 6 | 5 | 4 | 3 | 2 | 1 | 0 |
| P3CON0 | — | — | P35C0 | P34C0 | P33C0 | P32C0 | P31C0 | P30C0 |
| R/W | R/W | R/W | R/W | R/W | R/W | R/W | R/W | R/W |
| Initial value | 0 | 0 | 0 | 0 | 0 | 0 | 0 | 0 |

Address: 0F21BH
Access: R/W
Access size: 8-bit
Initial value: 00H

| | | | | | | | | |
|---------------|-----|-----|-------|-------|-------|-------|-------|-------|
| | 7 | 6 | 5 | 4 | 3 | 2 | 1 | 0 |
| P3CON1 | — | — | P35C1 | P34C1 | P33C1 | P32C1 | P31C1 | P30C1 |
| R/W | R/W | R/W | R/W | R/W | R/W | R/W | R/W | R/W |
| Initial value | 0 | 0 | 0 | 0 | 0 | 0 | 0 | 0 |

P3CON0 and P3CON1 are special function registers (SFRs) to select input/output state of the Port 3 pin. The input/output state is different between input mode and output mode. Input or output is selected by using the P3DIR register.

[Description of Bits]

- P35C1 to P30C1, P35C0 to P30C0** (bits 5 to 0)
 P35C1 to P30C1 and P35C0 to P30C0 are the bit bits for selecting the high-impedance output, P-channel open drain output, N-channel open drain output, or CMOS output in output mode and for selecting the high-impedance input, input with a pull-down resistor, or input with a pull-up resistor in input mode.

| Setting of P35 pin | | When output mode is selected (P35DIR bit = "0") | When input mode is selected (P35DIR bit = "1") |
|--------------------|-------|---|--|
| P35C1 | P35C0 | Description | |
| 0 | 0 | P35 pin: High-impedance output (initial value) | P35 pin: High-impedance input |
| 0 | 1 | P35 pin: P-channel open drain output | P35 pin: Input with a pull-down resistor |
| 1 | 0 | P35 pin: N-channel open drain output | P35 pin: Input with a pull-up resistor |
| 1 | 1 | P35 pin: CMOS output | P35 pin: High-impedance input |

| Setting of P34 pin | | When output mode is selected (P34DIR bit = "0") | When input mode is selected (P34DIR bit = "1") |
|--------------------|-------|---|--|
| P34C1 | P34C0 | Description | |
| 0 | 0 | P34 pin: High-impedance output (initial value) | P34 pin: High-impedance input |
| 0 | 1 | P34 pin: P-channel open drain output | P34 pin: Input with a pull-down resistor |
| 1 | 0 | P34 pin: N-channel open drain output | P34 pin: Input with a pull-up resistor |
| 1 | 1 | P34 pin: CMOS output | P34 pin: High-impedance input |

| Setting of P33 pin | | When output mode is selected (P33DIR bit = "0") | When input mode is selected (P33DIR bit = "1") |
|--------------------|-------|---|--|
| P33C1 | P33C0 | Description | |
| 0 | 0 | P33 pin: High-impedance output (initial value) | P33 pin: High-impedance input |
| 0 | 1 | P33 pin: P-channel open drain output | P33 pin: Input with a pull-down resistor |
| 1 | 0 | P33 pin: N-channel open drain output | P33 pin: Input with a pull-up resistor |
| 1 | 1 | P33 pin: CMOS output | P33 pin: High-impedance input |

| Setting of P32 pin | | When output mode is selected (P32DIR bit = "0") | When input mode is selected (P32DIR bit = "1") |
|--------------------|-------|---|--|
| P32C1 | P32C0 | Description | |
| 0 | 0 | P32 pin: High-impedance output (initial value) | P32 pin: High-impedance input |
| 0 | 1 | P32 pin: P-channel open drain output | P32 pin: Input with a pull-down resistor |
| 1 | 0 | P32 pin: N-channel open drain output | P32 pin: Input with a pull-up resistor |
| 1 | 1 | P32 pin: CMOS output | P32 pin: High-impedance input |

| Setting of P31 pin | | When output mode is selected (P31DIR bit = "0") | When input mode is selected (P31DIR bit = "1") |
|--------------------|-------|---|--|
| P31C1 | P31C0 | Description | |
| 0 | 0 | P31 pin: High-impedance output (initial value) | P31 pin: High-impedance input |
| 0 | 1 | P31 pin: P-channel open drain output | P31 pin: Input with a pull-down resistor |
| 1 | 0 | P31 pin: N-channel open drain output | P31 pin: Input with a pull-up resistor |
| 1 | 1 | P31 pin: CMOS output | P31 pin: High-impedance input |

| Setting of P30 pin | | When output mode is selected (P30DIR bit = "0") | When input mode is selected (P30DIR bit = "1") |
|--------------------|-------|---|--|
| P30C1 | P30C0 | Description | |
| 0 | 0 | P30 pin: High-impedance output (initial value) | P30 pin: High-impedance input |
| 0 | 1 | P30 pin: P-channel open drain output | P30 pin: Input with a pull-down resistor |
| 1 | 0 | P30 pin: N-channel open drain output | P30 pin: Input with a pull-up resistor |
| 1 | 1 | P30 pin: CMOS output | P30 pin: High-impedance input |

16.2.5 Port 3 Mode Register 0 (P3MOD0)

Address: 0F21CH
Access: R/W
Access size: 8/16 bit
Initial value: 00H

| | | | | | | | | |
|---------------|-----|-----|--------|--------|--------|--------|--------|--------|
| | 7 | 6 | 5 | 4 | 3 | 2 | 1 | 0 |
| P3MOD0 | — | — | P35MD0 | P34MD0 | P33MD0 | P32MD0 | P31MD0 | P30MD0 |
| R/W | R/W | R/W | R/W | R/W | R/W | R/W | R/W | R/W |
| Initial value | 0 | 0 | 0 | 0 | 0 | 0 | 0 | 0 |

P3MOD0 is a special function register (SFR) to select the primary function or the secondary function of Port 3.

[Description of Bits]

- **P35MD0** (bit 5)

The P35MD0 bit is used to select the primary or secondary function of the P35 pin.

| P35MD0 | Description |
|--------|---|
| 0 | General-purpose input/output mode (initial value) |
| 1 | RC oscillation monitor pin for RC-ADC |

- **P34MD0** (bit 4)

The P34MD0 bit is used to select the primary function or the secondary function of the P34 pin.

| P34MD0 | Description |
|--------|---|
| 0 | General-purpose input/output mode (initial value) |
| 1 | Resistor/capacitor sensor connection pin for measurement for RC-ADC (channel 0) |

- **P33MD0** (bit 3)

The P33MD0 bit is used to select the primary or secondary function of the P33 pin.

| P33MD0 | Description |
|--------|---|
| 0 | General-purpose input/output mode (initial value) |
| 1 | Resistor/capacitor sensor connection pin for measurement for RC-ADC (channel 0) |

- **P32MD0** (bit 2)

The P32MD0 bit is used to select the primary or secondary function of the P32 pin.

| P32MD0 | Description |
|--------|--|
| 0 | General-purpose input/output mode (initial value) |
| 1 | Reference resistor connection pin for RC-ADC (channel 0) |

- **P31MD0** (bit 1)

The P31MD0 bit is used to select the primary or secondary function of the P31 pin.

| P31MD0 | Description |
|--------|---|
| 0 | General-purpose input/output mode (initial value) |
| 1 | Reference capacitor connection pin for RC-ADC (channel 0) |

- **P30MD0** (bit 0)
The P30MD0 bit is used to select the primary or secondary function of the P30 pin.

| P30MD0 | Description |
|---------------|--|
| 0 | General-purpose input/output mode (initial value) |
| 1 | RC oscillation waveform input pin for RC-ADC (channel 0) |

Note:

When using the RC-ADC as the secondary function, set the P3DIR, P3CON0, and P3CON1 registers to bring each pin state to high-impedance input (same for when using the RC oscillation monitor function).

Pull-up or Pull-down input makes drawing the current.

16.3 Description of Operation

16.3.1 Input/Output Port Functions

For each pin of Port 3, either output or input is selected by setting the Port 3 direction register (P3DIR).

In output mode, high-impedance output mode, P-channel open drain output mode, N-channel open drain output mode, or CMOS output mode can be selected by setting the Port 3 control registers 0 and 1 (P3CON0 and P3CON1).

In input mode, high-impedance input mode, input mode with a pull-down resistor, or input mode with a pull-up resistor can be selected by setting the Port 3 control registers 0 and 1 (P3CON0 and P3CON1).

At a system reset, high-impedance output mode is selected as the initial state.

In output mode, “L” or “H” level is output to each pin of Port 3 depending on the value set by the Port 3 data register (P3D).

In input mode, the input level of each pin of Port 3 can be read from the Port 3 data register (P3D).

16.3.2 Secondary Function

The secondary function is assigned to Port 3 as the RC-ADC (channel 0) oscillation pins (IN0, CS0, RS0, RT0, CRT0, RCM). Each of them can be used as the secondary function by setting the P35MD0 to P30MD0 bits of the port 3 mode register (P3MOD0).

Note:

·All the Port 3 pins except P35/RCM are configured as pins dedicated to the RC-ADC function during A/D conversion. Therefore, if there is any unused pin, that pin cannot be used as its primary function during A/D conversion. For the RC-ADC, see Chapter 21, “RC Oscillation Type A/D Converter”.

Chapter 17

Port 4

17. Port 4

17.1 Overview

This LSI includes Port 4 (P40 to P47) which is an 8-bit input/output port.

This Port 4 can have the UART, RC-ADC, synchronous serial port, and PWM output functions as the secondary and tertiary functions.

For the UART, see Chapter 13, "UART." For the RC-ADC, see Chapter 21, "RC Oscillation Type A/D Converter." For the synchronous serial port, see Chapter 12, "Synchronous Serial Port." For the PWM, see Chapter 10, "PWM."

17.1.1 Features

- Allows selection of high-impedance output, P-channel open drain output, N-channel open drain output, or CMOS output for each bit in output mode.
- Allows selection of high-impedance input, input with a pull-down resistor, or input with a pull-up resistor for each bit in input mode.
- The P44 pin can be used as the external clock input pin for the Timer 0 and Timer 2 and the PWM0. The P45 pin can be used as the external clock input pin for the Timer 1 and Timer 3.
- The UART pins (RXD0, TXD0), RC-ADC (channel 1) oscillation pins (IN1, CS1, RS1, RT1), synchronous serial port pins (SIN0, SCK0, SOUT0), and PWM output pin (PWM0) can be used as the secondary functions.

17.1.2 Configuration

Figure 17-1 shows the configuration of Port 4.

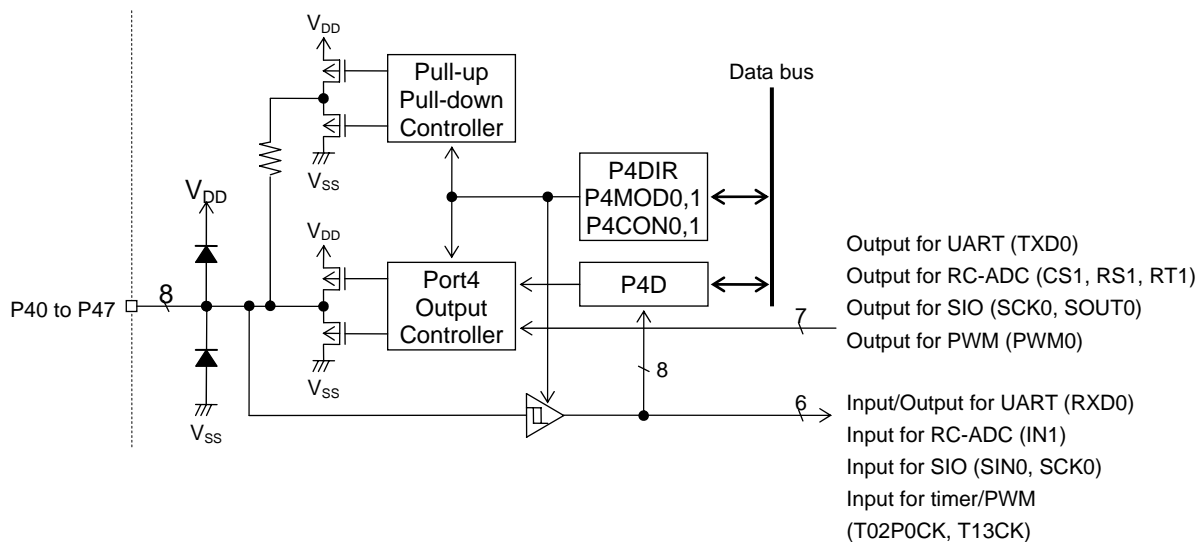

P4D : Port 4 data register
P4DIR : Port 4 direction register
P4CON0: Port 4 control register 0
P4CON1: Port 4 control register 1
P4MOD0 : Port 4 mode register 0
P4MOD1 : Port 4 mode register 1

Figure 17-1 Configuration of Port 4

17.1.3 List of Pins

| Pin name | I/O | Primary function | Secondary function | Tertiary function |
|------------------------|-----|---|--|------------------------------|
| P40/SIN0 | I/O | Input/output port | — | SSIO0 data input pin |
| P41/SCK0 | I/O | Input/output port | — | SSIO0 clock input/output pin |
| P42/RXD0/SOUT0 | I/O | Input/output port | UART0 data input pin | SSIO0 data output pin |
| P43/TXD0/PWM0 | I/O | Input/output port | UART0 data output pin | PWM0 output pin |
| P44/ T0P02CK /IN1/SIN0 | I/O | Input/output port, Timer0/Timer2/ PWM0 external clock input | RC oscillation waveform input pin for RC-ADC1 | SSIO0 data input pin |
| P45/ T13CK /CS1/SCK0 | I/O | Input/output port, Timer 1/ Timer 3 external clock input | Reference capacitor connection pin for RC-ADC1 | SSIO0 clock input/output pin |
| P46/RS1/SOUT0 | I/O | Input/output port | Reference resistor connection pin for RC-ADC1 | SSIO0 data output pin |
| P47/RT1 | I/O | Input/output port | Resistor sensor connection pin for measurement for RC-ADC1 | — |

17.2 Description of Registers

17.2.1 List of Registers

| Address | Name | Symbol (Byte) | Symbol (Word) | R/W | Size | Initial value |
|---------|---------------------------|---------------|---------------|-----|------|---------------|
| 0F220H | Port 4 data register | P4D | — | R/W | 8 | 00H |
| 0F221H | Port 4 direction register | P4DIR | — | R/W | 8 | 00H |
| 0F222H | Port 4 control register 0 | P4CON0 | P4CON | R/W | 8/16 | 00H |
| 0F223H | Port 4 control register 1 | P4CON1 | | R/W | 8 | 00H |
| 0F224H | Port 4 mode register 0 | P4MOD0 | P4MOD | R/W | 8/16 | 00H |
| 0F225H | Port 4 mode register 1 | P4MOD1 | | R/W | 8 | 00H |

17.2.2 Port 4 Data Register (P4D)

Address: 0F220H
 Access: R/W
 Access size: 8-bit
 Initial value: 00H

| | | | | | | | | |
|---------------|------|------|------|------|------|------|------|------|
| | 7 | 6 | 5 | 4 | 3 | 2 | 1 | 0 |
| P4D | P47D | P46D | P45D | P44D | P43D | P42D | P41D | P40D |
| R/W | R/W | R/W | R/W | R/W | R/W | R/W | R/W | R/W |
| Initial value | 0 | 0 | 0 | 0 | 0 | 0 | 0 | 0 |

P4D is a special function register (SFR) to set the value to be output to the Port 4 pin or to read the input level of the Port 4. In output mode, the value of this register is output to the Port 4 pin. The value written to P4D is readable. In input mode, the input level of the Port 4 pin is read when P4D is read. Output mode or input mode is selected by using the port direction register (P4DIR) described later.

[Description of Bits]

- **P47D to P40D** (bits 7 to 0)

The P47D to P40D bits are used to set the output value of the Port 4 pin in output mode and to read the pin level of the Port 4 pin in input mode.

| P47D | Description |
|------|---|
| 0 | Output or input level of the P47 pin: "L" |
| 1 | Output or input level of the P47 pin: "H" |

| P46D | Description |
|------|---|
| 0 | Output or input level of the P46 pin: "L" |
| 1 | Output or input level of the P46 pin: "H" |

| P45D | Description |
|------|---|
| 0 | Output or input level of the P45 pin: "L" |
| 1 | Output or input level of the P45 pin: "H" |

| P44D | Description |
|------|---|
| 0 | Output or input level of the P44 pin: "L" |
| 1 | Output or input level of the P44 pin: "H" |

| P43D | Description |
|------|---|
| 0 | Output or input level of the P43 pin: "L" |
| 1 | Output or input level of the P43 pin: "H" |

| P42D | Description |
|------|---|
| 0 | Output or input level of the P42 pin: "L" |
| 1 | Output or input level of the P42 pin: "H" |

| P41D | Description |
|------|---|
| 0 | Output or input level of the P41 pin: "L" |
| 1 | Output or input level of the P41 pin: "H" |

| P40D | Description |
|------|---|
| 0 | Output or input level of the P40 pin: "L" |
| 1 | Output or input level of the P40 pin: "H" |

17.2.3 Port 4 Direction Register (P4DIR)

Address: 0F221H
Access: R/W
Access size: 8-bit
Initial value: 00H

| | | | | | | | | |
|---------------|--------|--------|--------|--------|--------|--------|--------|--------|
| | 7 | 6 | 5 | 4 | 3 | 2 | 1 | 0 |
| P4DIR | P47DIR | P46DIR | P45DIR | P44DIR | P43DIR | P42DIR | P41DIR | P40DIR |
| R/W | R/W | R/W | R/W | R/W | R/W | R/W | R/W | R/W |
| Initial value | 0 | 0 | 0 | 0 | 0 | 0 | 0 | 0 |

P4DIR is a special function register (SFR) to select the input/output mode of Port 4.

[Description of Bits]

- **P47DIR to P40DIR** (bits 7 to 0)

P47DIR to P40DIR are the bits for selecting the input/output mode of the Port 4 pins.

| P47DIR | Description |
|--------|---------------------------------|
| 0 | P47 pin: Output (initial value) |
| 1 | P47 pin: Input |

| P46DIR | Description |
|--------|---------------------------------|
| 0 | P46 pin: Output (initial value) |
| 1 | P46 pin: Input |

| P45DIR | Description |
|--------|---------------------------------|
| 0 | P45 pin: Output (initial value) |
| 1 | P45 pin: Input |

| P44DIR | Description |
|--------|---------------------------------|
| 0 | P44 pin: Output (initial value) |
| 1 | P44 pin: Input |

| P43DIR | Description |
|--------|---------------------------------|
| 0 | P43 pin: Output (initial value) |
| 1 | P43 pin: Input |

| P42DIR | Description |
|--------|---------------------------------|
| 0 | P42 pin: Output (initial value) |
| 1 | P42 pin: Input |

| P41DIR | Description |
|--------|---------------------------------|
| 0 | P41 pin: Output (initial value) |
| 1 | P41 pin: Input |

| P40DIR | Description |
|--------|---------------------------------|
| 0 | P40 pin: Output (initial value) |
| 1 | P40 pin: Input |

17.2.4 Port 4 Control Registers 0, 1 (P4CON0, P4CON1)

Address: 0F222H
 Access: R/W
 Access size: 8/16 bit
 Initial value: 00H

| | | | | | | | | |
|---------------|-------|-------|-------|-------|-------|-------|-------|-------|
| | 7 | 6 | 5 | 4 | 3 | 2 | 1 | 0 |
| P4CON0 | P47C0 | P46C0 | P45C0 | P44C0 | P43C0 | P42C0 | P41C0 | P40C0 |
| R/W | R/W | R/W | R/W | R/W | R/W | R/W | R/W | R/W |
| Initial value | 0 | 0 | 0 | 0 | 0 | 0 | 0 | 0 |

Address: 0F223H
 Access: R/W
 Access size: 8-bit
 Initial value: 00H

| | | | | | | | | |
|---------------|-------|-------|-------|-------|-------|-------|-------|-------|
| | 7 | 6 | 5 | 4 | 3 | 2 | 1 | 0 |
| P4CON1 | P47C1 | P46C1 | P45C1 | P44C1 | P43C1 | P42C1 | P41C1 | P40C1 |
| R/W | R/W | R/W | R/W | R/W | R/W | R/W | R/W | R/W |
| Initial value | 0 | 0 | 0 | 0 | 0 | 0 | 0 | 0 |

P4CON0 and P4CON1 are special function registers (SFRs) to select input/output state of the Port 4 pin. The input/output state is different between input mode and output mode. Input or output is selected by using the P4DIR register.

[Description of Bits]

- P47C1 to P40C1, P47C0 to P40C0** (bits 7 to 0)
 P47C1 to P40C1 and P47C0 to P40C0 are the bits for selecting the high-impedance output, P-channel open drain output, N-channel open drain output, or CMOS output in output mode and for selecting the high-impedance input, input with a pull-down resistor, or input with a pull-up resistor in input mode.

| Setting of P47 pin | | When output mode is selected (P47DIR bit = "0") | When input mode is selected (P47DIR bit = "1") |
|--------------------|--------------|---|--|
| P47C1 | P47C0 | Description | |
| 0 | 0 | High-impedance output (initial value) | High-impedance input |
| 0 | 1 | P-channel open drain output | Input with a pull-down resistor |
| 1 | 0 | N-channel open drain output | Input with a pull-up resistor |
| 1 | 1 | CMOS output | High-impedance input |

| Setting of P46 pin | | When output mode is selected (P46DIR bit = "0") | When input mode is selected (P46DIR bit = "1") |
|--------------------|--------------|---|--|
| P46C1 | P46C0 | Description | |
| 0 | 0 | High-impedance output (initial value) | High-impedance input |
| 0 | 1 | P-channel open drain output | Input with a pull-down resistor |
| 1 | 0 | N-channel open drain output | Input with a pull-up resistor |
| 1 | 1 | CMOS output | High-impedance input |

| Setting of P45 pin | | When output mode is selected (P45DIR bit = "0") | When input mode is selected (P45DIR bit = "1") |
|--------------------|-------|---|--|
| P45C1 | P45C0 | Description | |
| 0 | 0 | High-impedance output (initial value) | High-impedance input |
| 0 | 1 | P-channel open drain output | Input with a pull-down resistor |
| 1 | 0 | N-channel open drain output | Input with a pull-up resistor |
| 1 | 1 | CMOS output | High-impedance input |

| Setting of P44 pin | | When output mode is selected (P44DIR bit = "0") | When input mode is selected (P44DIR bit = "1") |
|--------------------|-------|---|--|
| P44C1 | P44C0 | Description | |
| 0 | 0 | High-impedance output (initial value) | High-impedance input |
| 0 | 1 | P-channel open drain output | Input with a pull-down resistor |
| 1 | 0 | N-channel open drain output | Input with a pull-up resistor |
| 1 | 1 | CMOS output | High-impedance input |

| Setting of P43 pin | | When output mode is selected (P43DIR bit = "0") | When input mode is selected (P43DIR bit = "1") |
|--------------------|-------|---|--|
| P43C1 | P43C0 | Description | |
| 0 | 0 | High-impedance output (initial value) | High-impedance input |
| 0 | 1 | P-channel open drain output | Input with a pull-down resistor |
| 1 | 0 | N-channel open drain output | Input with a pull-up resistor |
| 1 | 1 | CMOS output | High-impedance input |

| Setting of P42 pin | | When output mode is selected (P42DIR bit = "0") | When input mode is selected (P42DIR bit = "1") |
|--------------------|-------|---|--|
| P42C1 | P42C0 | Description | |
| 0 | 0 | High-impedance output (initial value) | High-impedance input |
| 0 | 1 | P-channel open drain output | Input with a pull-down resistor |
| 1 | 0 | N-channel open drain output | Input with a pull-up resistor |
| 1 | 1 | CMOS output | High-impedance input |

| Setting of P41 pin | | When output mode is selected (P41DIR bit = "0") | When input mode is selected (P41DIR bit = "1") |
|--------------------|-------|---|--|
| P41C1 | P41C0 | Description | |
| 0 | 0 | High-impedance output (initial value) | High-impedance input |
| 0 | 1 | P-channel open drain output | Input with a pull-down resistor |
| 1 | 0 | N-channel open drain output | Input with a pull-up resistor |
| 1 | 1 | CMOS output | High-impedance input |

| Setting of P40 pin | | When output mode is selected (P40DIR bit = "0") | When input mode is selected (P40DIR bit = "1") |
|--------------------|-------|---|--|
| P40C1 | P40C0 | Description | |
| 0 | 0 | High-impedance output (initial value) | High-impedance input |
| 0 | 1 | P-channel open drain output | Input with a pull-down resistor |
| 1 | 0 | N-channel open drain output | Input with a pull-up resistor |
| 1 | 1 | CMOS output | High-impedance input |

17.2.5 Port 4 Mode Registers 0, 1 (P4MOD0, P4MOD1)

Address: 0F224H
 Access: R/W
 Access size: 8/16 bit
 Initial value: 00H

| | | | | | | | | |
|---------------|--------|--------|--------|--------|--------|--------|--------|--------|
| | 7 | 6 | 5 | 4 | 3 | 2 | 1 | 0 |
| P4MOD0 | P47MD0 | P46MD0 | P45MD0 | P44MD0 | P43MD0 | P42MD0 | P41MD0 | P40MD0 |
| R/W | R/W | R/W | R/W | R/W | R/W | R/W | R/W | R/W |
| Initial value | 0 | 0 | 0 | 0 | 0 | 0 | 0 | 0 |

Address: 0F225H
 Access: R/W
 Access size: 8-bit
 Initial value: 00H

| | | | | | | | | |
|---------------|--------|--------|--------|--------|--------|--------|--------|--------|
| | 7 | 6 | 5 | 4 | 3 | 2 | 1 | 0 |
| P4MOD1 | P47MD1 | P46MD1 | P45MD1 | P44MD1 | P43MD1 | P42MD1 | P41MD1 | P40MD1 |
| R/W | R/W | R/W | R/W | R/W | R/W | R/W | R/W | R/W |
| Initial value | 0 | 0 | 0 | 0 | 0 | 0 | 0 | 0 |

P4MOD0 and P4MOD1 are special function registers (SFRs) to select the primary, secondary, or tertiary function of Port 4.

[Description of Bits]

- **P47MD1, P47MD0** (bit 7)

The P47MD1 and P47MD0 bits are used to select the primary or secondary function of the P47 pin.

| P47MD1 | P47MD0 | Description |
|--------|--------|---|
| 0 | 0 | General-purpose input/output mode (initial value) |
| 0 | 1 | Resistor sensor connection pin for measurement for RC-ADC (channel 1) |
| 1 | 0 | Prohibited |
| 1 | 1 | Prohibited |

- **P46MD1, P46MD0** (bit 6)

The P46MD1 and P46MD0 bits are used to select the primary, secondary, or tertiary function of the P46 pin.

| P46MD1 | P46MD0 | Description |
|--------|--------|--|
| 0 | 0 | General-purpose input/output mode (initial value) |
| 0 | 1 | Reference resistor connection pin for RC-ADC (channel 1) |
| 1 | 0 | SIO0 data output pin |
| 1 | 1 | Prohibited |

- **P45MD1, P45MD0** (bit 5)

The P45MD1 and P45MD0 bits are used to select the primary, secondary, or tertiary function of the P45 pin.

| P45MD1 | P45MD0 | Description |
|--------|--------|---|
| 0 | 0 | General-purpose input/output mode (initial value) |
| 0 | 1 | Reference capacitor connection pin for RC-ADC (channel 1) |
| 1 | 0 | SIO0 clock input/output pin |
| 1 | 1 | Prohibited |

- **P44MD1, P44MD0** (bit 4)

The P44MD1 and P44MD0 bits are used to select the primary, secondary, or tertiary function of the P44 pin.

| P44MD1 | P44MD0 | Description |
|--------|--------|---|
| 0 | 0 | General-purpose input/output mode (initial value) |
| 0 | 1 | RC oscillation waveform input pin for RC-AD (channel 1) |
| 1 | 0 | SIO0 data input pin |
| 1 | 1 | Prohibited |

- **P43MD1, P43MD0** (bit 3)

The P43MD1 and P43MD0 bits are used to select the primary, secondary, or tertiary function of the P43 pin.

| P43MD1 | P43MD0 | Description |
|--------|--------|---|
| 0 | 0 | General-purpose input/output mode (initial value) |
| 0 | 1 | UART0 data output pin |
| 1 | 0 | PWM0 output pin |
| 1 | 1 | Prohibited |

- **P42MD1, P42MD0** (bit 2)

The P42MD1 and P42MD0 bits are used to select the primary, secondary, or tertiary function of the P42 pin.

| P42MD1 | P42MD0 | Description |
|--------|--------|---|
| 0 | 0 | General-purpose input/output mode (initial value) |
| 0 | 1 | UART0 data input pin |
| 1 | 0 | SIO0 data output pin |
| 1 | 1 | Prohibited |

- **P41MD1, P41MD0** (bit 1)

The P41MD1 and P41MD0 bits are used to select the primary or tertiary function of the P41 pin.

| P41MD1 | P41MD0 | Description |
|--------|--------|---|
| 0 | 0 | General-purpose input/output mode (initial value) |
| 0 | 1 | Prohibited |
| 1 | 0 | SIO0 clock input/output pin |
| 1 | 1 | Prohibited |

- **P40MD1, P40MD0** (bit 0)

The P40MD1 and P40MD0 bits are used to select the primary or tertiary function of the P40 pin.

| P40MD1 | P40MD0 | Description |
|--------|--------|---|
| 0 | 0 | General-purpose input/output mode (initial value) |
| 0 | 1 | Prohibited |
| 1 | 0 | SIO0 data input pin |
| 1 | 1 | Prohibited |

Note:

When the pin is set to "Prohibited" and the output mode is selected (by the Port 4 control register), the Port 4 output pin state is fixed as follows regardless of the data of the port data register P4D:

When high-impedance output is selected: Output pin is high-impedance

When P-channel open drain output is selected: Output pin is high-impedance

When N-channel open drain output is selected: Output pin is fixed to "L"

When CMOS output is selected: Output pin is fixed to "L"

When using the RC-ADC as the secondary function, set the P4DIR, P4CON0, and P4CON1 registers to bring each pin state to high-impedance input. Pull-up or Pull-down input makes drawing the current.

When using the P44 pin as SIO0 data input, set the P40 pin not to be thertialy function in the P4MOD0 and P4MOD1 registers.

17.3 Description of Operation

17.3.1 Input/Output Port Functions

For each pin of Port 4, either output or input is selected by setting the Port 4 direction register (P4DIR).

In output mode, high-impedance output mode, P-channel open drain output mode, N-channel open drain output mode, or CMOS output mode can be selected by setting the Port 4 control registers 0 and 1 (P4CON0 and P4CON1).

In input mode, high-impedance input mode, input mode with a pull-down resistor, or input mode with a pull-up resistor can be selected by setting the Port 4 control registers 0 and 1 (P4CON0 and P4CON1).

At a system reset, high-impedance output mode is selected as the initial state.

In output mode, “L” or “H” level is output to each pin of Port 4 depending on the value set by the Port 4 data register (P4D).

In input mode, the input level of each pin of Port 4 can be read from the Port 4 data register (P4D).

17.3.2 Secondary and Tertiary Functions

The secondary and tertiary functions are assigned to Port 4 as the UART0 pins (RXD0, TXD0), RC-ADC (channel 1) oscillation pins (IN1, CS1, RS1, RT1), synchronous serial port 0 pins (SIN0, SCK0, SOUT), and the PWM output pin (PWM0). These pins can be used in a secondary or tertiary function mode by setting the P47MD0 to P40MD0 bits and the P47MD1 to P40MD1 bits of the Port 4 mode registers (P4MOD0, P4MOD1).

Note:

The P44 to P47 pins of Port 4 are configured as pins dedicated to the RC-ADC function during A/D conversion. Therefore, if any of them is unused, it cannot be used as the primary function (or as the port). For the RC-ADC, see Chapter 21, “RC Oscillation Type A/D Converter”.

Chapter 18

Port 5

18. Port 5

18.1 Overview

This LSI includes Port 5 (P50 to P57) which is an 8-bit input/output port.

18.1.1 Features

- Allows selection of N-channel open drain output or CMOS output for each bit in the output mode.
- Allows selection of high-impedance input or input with a pull-down/pull-up resistor for each bit in the input mode.
- Allows selection of interrupt disabled or interrupt enabled for each bit in the input mode.
- The synchronous serial port pins (SIN1, SCK1, SOUT1) and the Melody 0 (MD0) are available as the secondary and tertiary function.

18.1.2 Configuration

Figure 18-1 shows the configuration of Port 5.

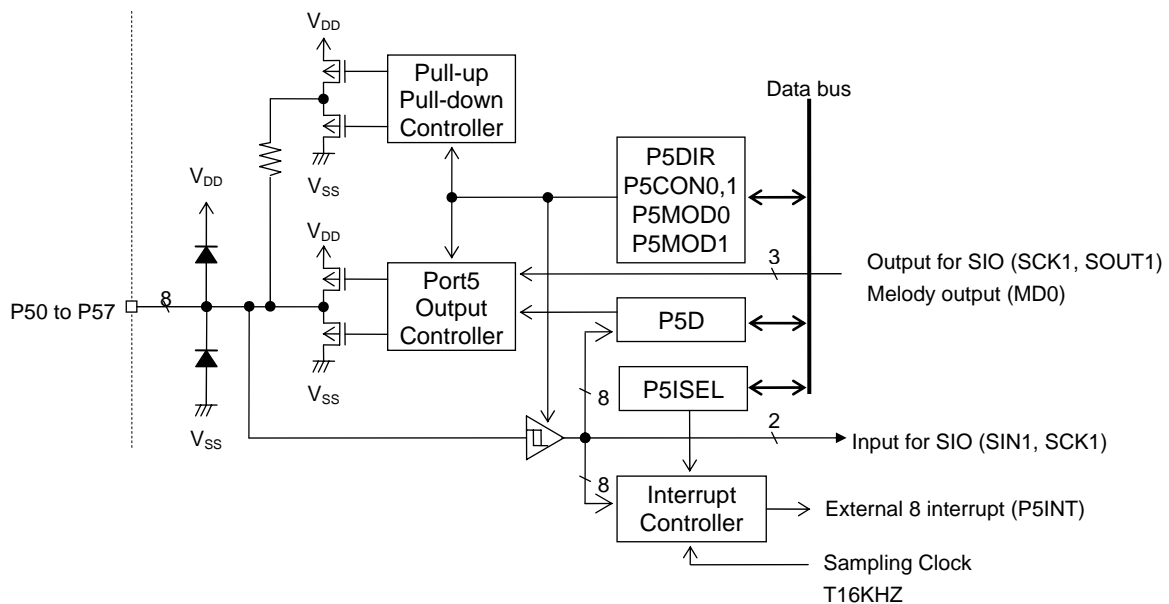

P5D : Port 5 data register
P5DIR : Port 5 direction register
P5CON0: Port 5 control register 0
P5CON1: Port 5 control register 1
P5MOD0 : Port 5 mode register 0
P5MOD1 : Port 5 mode register 1
P5ISEL : Port 5 interrupt mode register

Figure 18-1 Configuration of Port 5

18.1.3 List of Pins

| Pin name | Input/output | Primary function | Secondary Function | Tertiary Function |
|-------------------|--------------|--|--------------------|--------------------------------------|
| P50/EXI8/MD0/SIN1 | I/O | Input/output port, External 8 interrupt | Melody 0 output | SSIO1 data input |
| P51/EXI8/SCK1 | I/O | Input/output port, External 8 interrupt | — | SSIO1 synchronous clock input/output |
| P52/EXI8/SOUT1 | I/O | Input/output port, External 8 interrupt | — | SSIO1 data output |
| P53/EXI8/MD0 | I/O | Input/output port, External 8 interrupt | — | — |
| P54/EXI8 | I/O | Input/output port, External 8 interrupt | — | SSIO1 data input |
| P55/EXI8/SIN1 | I/O | Input/output port, External 8 interrupt | — | SSIO1 synchronous clock input/output |
| P56/EXI8/SCK1 | I/O | Input/output port, External 8 interrupt | — | SSIO1 data output |
| P57/EXI8/SOUT1 | I/O | Input/output port, External 8 interrupt | — | — |

18.2 Description of Registers

18.2.1 List of Registers

| Address | Name | Symbol (Byte) | Symbol (Word) | R/W | Size | Initial value |
|---------|--------------------------------|---------------|---------------|-----|------|---------------|
| 0F228H | Port 5 data register | P5D | — | R/W | 8 | 0FFH |
| 0F229H | Port 5 direction register | P5DIR | — | R/W | 8 | 00H |
| 0F22AH | Port 5 control register 0 | P5CON0 | P5CON | R/W | 8/16 | 00H |
| 0F22BH | Port 5 control register 1 | P5CON1 | | R/W | 8 | 00H |
| 0F22CH | Port 5 mode register 0 | P5MOD0 | P5MOD | R/W | 8/16 | 00H |
| 0F22DH | Port 5 mode register 1 | P5MOD1 | | R/W | 8 | 00H |
| 0F22EH | Port 5 interrupt mode register | P5ISEL | — | R/W | 8 | 00H |

18.2.2 Port 5 Data Register (P5D)

Address: 0F228H
 Access: R/W
 Access size: 8-bit
 Initial value: 0FFH

| | | | | | | | | |
|---------------|------|------|------|------|------|------|------|------|
| | 7 | 6 | 5 | 4 | 3 | 2 | 1 | 0 |
| P5D | P57D | P56D | P55D | P54D | P53D | P52D | P51D | P50D |
| R/W | R/W | R/W | R/W | R/W | R/W | R/W | R/W | R/W |
| Initial value | 1 | 1 | 1 | 1 | 1 | 1 | 1 | 1 |

P5D is a special function register (SFR) to set the value to be output to the Port 5 pin or to read the input level of the Port 5. In output mode, the value of this register is output to the Port 5 pin. The value written to P5D is readable.

In input mode, the input level of the Port 5 pin is read when P5D is read. Output mode or input mode is selected by using the port direction register (P5DIR) described later.

[Description of Bits]

- **P57D to P50D** (bit 7 to 0)

The P57D to P50D bits are used to set the output value of the Port 5 pin in output mode and to read the pin level of the Port 5 pin in input mode.

| P57D | Description |
|------|---|
| 0 | Output or input level of the P57 pin: "L" |
| 1 | Output or input level of the P57 pin: "H" |

| P56D | Description |
|------|---|
| 0 | Output or input level of the P56 pin: "L" |
| 1 | Output or input level of the P56 pin: "H" |

| P55D | Description |
|------|---|
| 0 | Output or input level of the P55 pin: "L" |
| 1 | Output or input level of the P55 pin: "H" |

| P54D | Description |
|------|---|
| 0 | Output or input level of the P54 pin: "L" |
| 1 | Output or input level of the P54 pin: "H" |

| P53D | Description |
|------|---|
| 0 | Output or input level of the P53 pin: "L" |
| 1 | Output or input level of the P53 pin: "H" |

| P52D | Description |
|------|---|
| 0 | Output or input level of the P52 pin: "L" |
| 1 | Output or input level of the P52 pin: "H" |

| P51D | Description |
|------|---|
| 0 | Output or input level of the P51 pin: "L" |
| 1 | Output or input level of the P51 pin: "H" |

| P50D | Description |
|------|---|
| 0 | Output or input level of the P50 pin: "L" |
| 1 | Output or input level of the P50 pin: "H" |

18.2.3 Port 5 Direction Register (P5DIR)

Address: 0F229H
Access: R/W
Access size: 8-bit
Initial value: 00H

| | | | | | | | | |
|---------------|--------|--------|--------|--------|--------|--------|--------|--------|
| | 7 | 6 | 5 | 4 | 3 | 2 | 1 | 0 |
| P5DIR | P57DIR | P56DIR | P55DIR | P54DIR | P53DIR | P52DIR | P51DIR | P50DIR |
| R/W | R/W | R/W | R/W | R/W | R/W | R/W | R/W | R/W |
| Initial value | 0 | 0 | 0 | 0 | 0 | 0 | 0 | 0 |

P5DIR is a special function register (SFR) to select the input/output mode of Port 5.

[Description of Bits]

- **P57DIR to P50DIR** (bit 7 to 0)

The P57DIR to P50DIR pins are used to set the input/output direction of the Port 5 pin.

| P57DIR | Description |
|--------|---------------------------------|
| 0 | P57 pin: Output (initial value) |
| 1 | P57 pin: Input |

| P56DIR | Description |
|--------|---------------------------------|
| 0 | P56 pin: Output (initial value) |
| 1 | P56 pin: Input |

| P55DIR | Description |
|--------|---------------------------------|
| 0 | P55 pin: Output (initial value) |
| 1 | P55 pin: Input |

| P54DIR | Description |
|--------|---------------------------------|
| 0 | P54 pin: Output (initial value) |
| 1 | P54 pin: Input |

| P53DIR | Description |
|--------|---------------------------------|
| 0 | P53 pin: Output (initial value) |
| 1 | P53 pin: Input |

| P52DIR | Description |
|--------|---------------------------------|
| 0 | P52 pin: Output (initial value) |
| 1 | P52 pin: Input |

| P51DIR | Description |
|--------|---------------------------------|
| 0 | P51 pin: Output (initial value) |
| 1 | P51 pin: Input |

| P50DIR | Description |
|--------|---------------------------------|
| 0 | P50 pin: Output (initial value) |
| 1 | P50 pin: Input |

18.2.4 Port 5 Control Registers 0 and 1 (P5CON0 and P5CON1)

Address: 0F22AH
Access: R/W
Access size: 8/16 bit
Initial value: 00H

| | | | | | | | | |
|---------------|-------|-------|-------|-------|-------|-------|-------|-------|
| | 7 | 6 | 5 | 4 | 3 | 2 | 1 | 0 |
| P5CON0 | P57C0 | P56C0 | P55C0 | P54C0 | P53C0 | P52C0 | P51C0 | P50C0 |
| R/W | R/W | R/W | R/W | R/W | R/W | R/W | R/W | R/W |
| Initial value | 0 | 0 | 0 | 0 | 0 | 0 | 0 | 0 |

Address: 0F22BH
Access: R/W
Access size: 8-bit
Initial value: 00H

| | | | | | | | | |
|---------------|-----|-----|-----|-----|-----|-----|-----|------|
| | 7 | 6 | 5 | 4 | 3 | 2 | 1 | 0 |
| P5CON1 | — | — | — | — | — | — | — | P5UD |
| R/W | R/W | R/W | R/W | R/W | R/W | R/W | R/W | R/W |
| Initial value | 0 | 0 | 0 | 0 | 0 | 0 | 0 | 0 |

P5CON0 and P5CON1 are special function registers (SFRs) to select input/output state of the Port 5 pin. The input/output state is different between input mode and output mode. Input or output is selected by using the P5DIR register.

[Description of Bits]

- P57C0 to P50C0** (bit 7 to 0)
 P57C0 to P50C0 are the bits that select N-channel open drain output or CMOS output in the output mode, and high-impedance input or input with a pull-down or pull-up resistor in the input mode.

| | | |
|--------------------|---|--|
| Setting of P57 pin | When output mode is selected (P57DIR bit = "0") | When input mode is selected (P57DIR bit = "1") |
| P57C0 | Description | |
| 0 | N-channel open drain output (initial value) | Input with a pull-down or pull-up resistor |
| 1 | CMOS output | High-impedance input |

| | | |
|--------------------|---|--|
| Setting of P56 pin | When output mode is selected (P56DIR bit = "0") | When input mode is selected (P56DIR bit = "1") |
| P56C0 | Description | |
| 0 | N-channel open drain output (initial value) | Input with a pull-down or pull-up resistor |
| 1 | CMOS output | High-impedance input |

| | | |
|--------------------|---|--|
| Setting of P55 pin | When output mode is selected (P55DIR bit = "0") | When input mode is selected (P55DIR bit = "1") |
| P55C0 | Description | |
| 0 | N-channel open drain output (initial value) | Input with a pull-down or pull-up resistor |
| 1 | CMOS output | High-impedance input |

| | | |
|--------------------|---|--|
| Setting of P54 pin | When output mode is selected (P54DIR bit = "0") | When input mode is selected (P54DIR bit = "1") |
| P54C0 | Description | |
| 0 | N-channel open drain output (initial value) | Input with a pull-down or pull-up resistor |
| 1 | CMOS output | High-impedance input |

| | | |
|--------------------|---|--|
| Setting of P53 pin | When output mode is selected (P53DIR bit = "0") | When input mode is selected (P53DIR bit = "1") |
| P53C0 | Description | |
| 0 | N-channel open drain output (initial value) | Input with a pull-down or pull-up resistor |
| 1 | CMOS output | High-impedance input |

| | | |
|--------------------|---|--|
| Setting of P52 pin | When output mode is selected (P52DIR bit = "0") | When input mode is selected (P52DIR bit = "1") |
| P52C0 | Description | |
| 0 | N-channel open drain output (initial value) | Input with a pull-down or pull-up resistor |
| 1 | CMOS output | High-impedance input |

| | | |
|--------------------|---|--|
| Setting of P51 pin | When output mode is selected (P51DIR bit = "0") | When input mode is selected (P51DIR bit = "1") |
| P51C0 | Description | |
| 0 | N-channel open drain output (initial value) | Input with a pull-down or pull-up resistor |
| 1 | CMOS output | High-impedance input |

| | | |
|--------------------|---|--|
| Setting of P50 pin | When output mode is selected (P50DIR bit = "0") | When input mode is selected (P50DIR bit = "1") |
| P50C0 | Description | |
| 0 | N-channel open drain output (initial value) | Input with a pull-down or pull-up resistor |
| 1 | CMOS output | High-impedance input |

- **P5UD** (bit 0)
P5UD is the bit that selects input with a pull-up resistor or input with a pull-down resistor when the input with a pull-down or pull-up resistor is selected.

| | |
|----------------------------|--|
| Setting of each port 5 pin | When the input with a pull-down or pull-up resistor mode is selected (P5nDIR bit = "1", P5nC0 = "0") (n = 0,1,2,3,4,5,6,7) |
| P5UD | Description |
| 0 | Input with a pull-up resistor (initial value) |
| 1 | Input with a pull-down resistor |

18.2.5 Port 5 Mode Register 0 and 1 (P5MOD0 and P5MOD1)

Address: 0F22CH
 Access: R/W
 Access size: 8/16-bit
 Initial value: 00H

| | | | | | | | | |
|---------------|-----|--------|--------|--------|-----|--------|--------|--------|
| | 7 | 6 | 5 | 4 | 3 | 2 | 1 | 0 |
| P5MOD0 | — | P56MD0 | P55MD0 | P54MD0 | — | P52MD0 | P51MD0 | P50MD0 |
| R/W | R/W | R/W | R/W | R/W | R/W | R/W | R/W | R/W |
| Initial value | 0 | 0 | 0 | 0 | 0 | 0 | 0 | 0 |

Address: 0F22DH
 Access: R/W
 Access size: 8-bit
 Initial value: 00H

| | | | | | | | | |
|---------------|-----|--------|--------|--------|-----|--------|--------|--------|
| | 7 | 6 | 5 | 4 | 3 | 2 | 1 | 0 |
| P5MOD1 | — | P56MD1 | P55MD1 | P54MD1 | — | P52MD1 | P51MD1 | P50MD1 |
| R/W | R/W | R/W | R/W | R/W | R/W | R/W | R/W | R/W |
| Initial value | 0 | 0 | 0 | 0 | 0 | 0 | 0 | 0 |

P5MOD0 and P5MOD1 are special function registers (SFRs) to select the primary function or the secondary function of Port 5.

[Description of Bits]

- **P56MD1, P56MD0** (bit 6)

The P56MD1 and P56MD0 bit is used to select the primary, secondary, or the tertiary function of the P56 pin.

| P56MD1 | P56MD0 | Description |
|--------|--------|---|
| 0 | 0 | General-purpose input/output mode (initial value) |
| 0 | 1 | Prohibited |
| 1 | 0 | SSIO1 data output |
| 1 | 1 | Prohibited |

- **P55MD1, P55MD0** (bit 5)

The P55MD1 and P55MD0 bit is used to select the primary, secondary, or the tertiary function of the P55 pin.

| P55MD1 | P55MD0 | Description |
|--------|--------|---|
| 0 | 0 | General-purpose input/output mode (initial value) |
| 0 | 1 | Prohibited |
| 1 | 0 | SSIO1 synchronous clock input/output |
| 1 | 1 | Prohibited |

- **P54MD1, P54MD0** (bit 0)

The P54MD1 and P54MD0 bit is used to select the primary, secondary, or the tertiary function of the P54 pin.

| P54MD1 | P54MD0 | Description |
|--------|--------|---|
| 0 | 0 | General-purpose input/output mode (initial value) |
| 0 | 1 | Melody 0 output |
| 1 | 0 | SSIO1 data input |
| 1 | 1 | Prohibited |

- **P52MD1, P52MD0** (bit 2)

The P52MD1 and P52MD0 bit is used to select the primary, secondary, or the tertiary function of the P52 pin.

| P52MD1 | P52MD0 | Description |
|--------|--------|---|
| 0 | 0 | General-purpose input/output mode (initial value) |
| 0 | 1 | Prohibited |
| 1 | 0 | SSIO1 data output |
| 1 | 1 | Prohibited |

- **P51MD1,P51MD0** (bit 1)

The P51MD1 and P51MD0 bit is used to select the primary, secondary, or the tertiary function of the P51 pin.

| P51MD1 | P51MD0 | Description |
|--------|--------|---|
| 0 | 0 | General-purpose input/output mode (initial value) |
| 0 | 1 | Prohibited |
| 1 | 0 | SSIO1 synchronous clock input/output |
| 1 | 1 | Prohibited |

- **P50MD1, P50MD0** (bit 0)

The P50MD1 and P50MD0 bit is used to select the primary, secondary, or the tertiary function of the P50 pin.

| P50MD1 | P50MD0 | Description |
|--------|--------|---|
| 0 | 0 | General-purpose input/output mode (initial value) |
| 0 | 1 | Melody 0 output |
| 1 | 0 | SSIO1 data input |
| 1 | 1 | Prohibited |

Note:

When the pin is set to "Prohibited" and the output mode is selected (by the Port 5 control register), the Port 5 output pin state is fixed as follows regardless of the data of the port data register P5D:

When N-channel open drain output is selected: Output pin is fixed to "L"

When CMOS output is selected: Output pin is fixed to "L"

When using the P54 pin as SIO1 data input, set the P50 pin not to be thertialy function in the P5MOD0 and P5MOD1 registers.

18.2.6 Port 5 Interrupt Mode Register (P5ISEL)

Address: 0F22EH
 Access: R/W
 Access size: 8-bit
 Initial value: 00H

| | | | | | | | | |
|---------------|-------|-------|-------|-------|-------|-------|-------|-------|
| | 7 | 6 | 5 | 4 | 3 | 2 | 1 | 0 |
| P5ISEL | P57IS | P56IS | P55IS | P54IS | P53IS | P52IS | P51IS | P50IS |
| R/W | R/W | R/W | R/W | R/W | R/W | R/W | R/W | R/W |
| Initial value | 0 | 0 | 0 | 0 | 0 | 0 | 0 | 0 |

P5ISEL is a special function register (SFR) to select the pin used for the Port 5 external interrupt (P5INT).

[Description of Bits]

- **P57IS to P50IS** (bit 7 to 0)
 P57IS to P50IS are the bits that select to disable or enable the interrupt of each pin on the Port 5.

| P57IS | Description |
|-------|---|
| 0 | P57 external interrupt disabled (initial value) |
| 1 | P57 external interrupt enabled |

| P56IS | Description |
|-------|---|
| 0 | P56 external interrupt disabled (initial value) |
| 1 | P56 external interrupt enabled |

| P55IS | Description |
|-------|---|
| 0 | P55 external interrupt disabled (initial value) |
| 1 | P55 external interrupt enabled |

| P54IS | Description |
|-------|---|
| 0 | P54 external interrupt disabled (initial value) |
| 1 | P54 external interrupt enabled |

| P53IS | Description |
|-------|---|
| 0 | P53 external interrupt disabled (initial value) |
| 1 | P53 external interrupt enabled |

| P52IS | Description |
|-------|---|
| 0 | P52 external interrupt disabled (initial value) |
| 1 | P52 external interrupt enabled |

| P51IS | Description |
|-------|---|
| 0 | P51 external interrupt disabled (initial value) |
| 1 | P51 external interrupt enabled |

| P50IS | Description |
|-------|---|
| 0 | P50 external interrupt disabled (initial value) |
| 1 | P50 external interrupt enabled |

18.3 Description of Operation

18.3.1 Input/Output Port Functions

For each pin of Port 5, either output or input is selected by setting the Port 5 direction register (P5DIR).

In the output mode, set the Port 5 control register 0 (P5CON0) to select either N-channel open drain output mode or CMOS output mode.

In the input mode, set the Port 5 control registers 0 and 1 (P5CON0 and P5CON1) to select any of high-impedance input mode, input mode with a pull-down resistor, or input mode with a pull-up resistor.

At the system reset, N-channel open drain output mode is selected as the initial state.

In output mode, the "L" or "H" level is output to each pin of Port 5 depending on the value set by the Port 5 data register (P5D).

In input mode, the input level of each pin of Port 5 is read from the Port 5 data register (P5D).

18.3.2 Secondary and Tertiary Functions

The Port 5 is assigned with the pins for Melody 0 (MD0) output as the secondary function and the pins for Synchronous serial port 1 (SIN1, SCK1, SOUT1) as the tertiary function. Each of them can be used as the secondary or tertiary function by setting the P57MD1 to P50MD1 and P57MD0 to P50MD0 bits of the port mode register 1 (P5MOD1) and 0 (P5MOD0).

18.3.3 External Interrupt

Each of the Port 5 pins (P50 to P57) can be used as the external 8 interrupt (P5INT). Each interrupt is maskable and selectable to be disabled or enabled. For details of interrupts, see Chapter 5, "Interrupts".

18.3.4 Interrupt Request

The maskable external 8 interrupt (P5INT) occurs when each of the Port 5 pins has an interrupt edge. Figure 18-2 shows the external 8 interrupt (P5INT) generation timing in case P5UD bit of P5CON1 register is "1". Figure 18-3 shows the external 8 interrupt (P5INT) generation timing in case P5UD bit of P5CON1 register is "0".

Note:

- The external 8 interrupt (P5INT) is fixed to both-edge interrupt with sampling.
- In STOP mode, since the 16 kHz sampling clock stops, no sampling is performed.
- Depending on the P5n pin state, the External 8 Interrupt Request flag (IRQ2's bit 3) may be set to "1" when the P5ISEL setting is changed. Therefore, change the P5ISEL setting when the Master Interrupt Enable (MIE) flag is "0", then reset the External 8 Interrupt Request flag to "0" by software before setting the MIE to "1". For interrupts, see Chapter 5, "Interrupts."

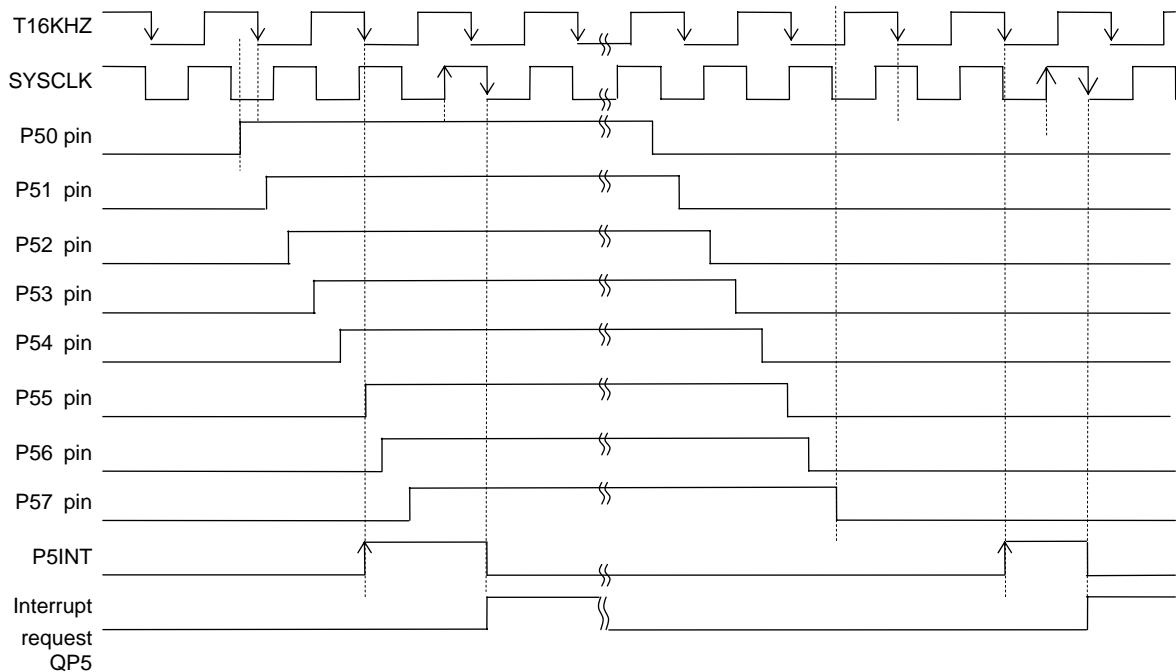

With sampling, both-edge interrupt

Figure 18-2 External 8 Interrupt Generation Timing (P5UD = 1)

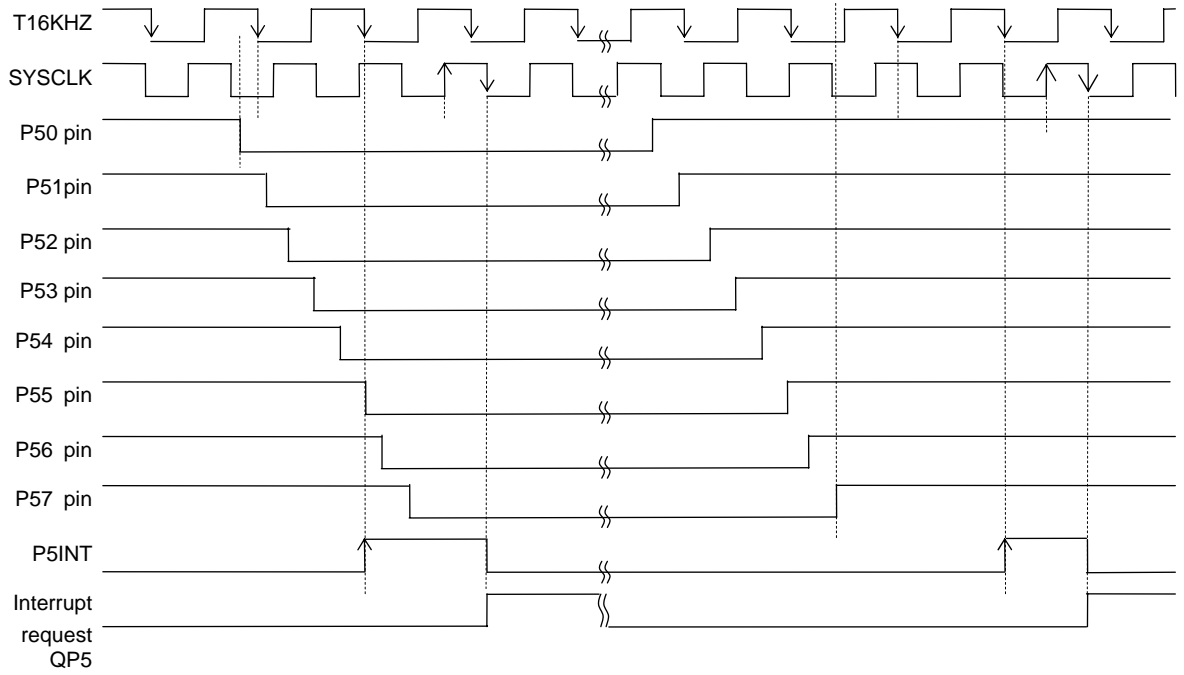

With sampling, both-edge interrupt

Figure 18-3 External 8 Interrupt Generation Timing (P5UD = 0)

Chapter 19

Port 6

19. Port 6

19.1 Overview

| | |
|----------|---|
| ML610407 | Includes Port 6 (P60 to P67) which is an 8-bit output port. |
| ML610408 | Includes Port 6 (P60 to P63) which is a 4-bit output port. |
| ML610409 | This function is not included. |

19.1.1 Features

- Allows selection of N-channel open drain output or CMOS output for each bit.

19.1.2 Configuration

Figure 19-1 shows the configuration of Port 6.

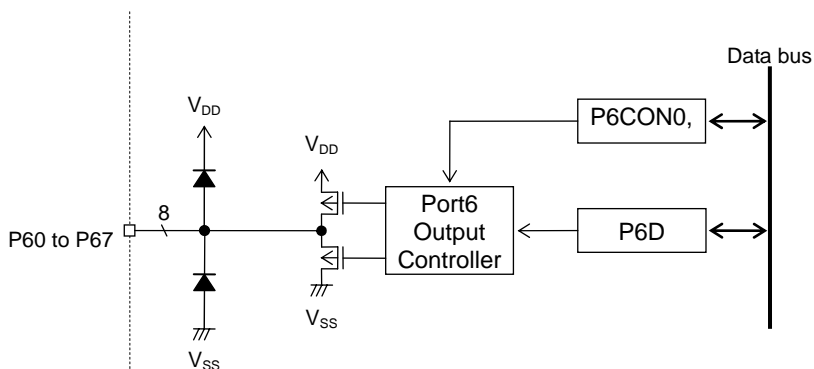

P6D : Port 6 data register
P6CON0: Port 6 control register 0

Figure 19-1 Configuration of Port 6

19.1.3 List of Pins

| Pin name | Output | Function |
|----------|--------|-------------|
| P60 | O | Output port |
| P61 | O | Output port |
| P62 | O | Output port |
| P63 | O | Output port |
| P64 | O | Output port |
| P65 | O | Output port |
| P66 | O | Output port |
| P67 | O | Output port |

19.2 Description of Registers

19.2.1 List of Registers

| Address | Name | Symbol (Byte) | Symbol (Word) | R/W | Size | Initial value |
|---------|---------------------------|---------------|---------------|-----|------|--|
| 0F230H | Port 6 data register | P6D | — | R/W | 8 | 0FFH ^{(*)1} 00FH ^{(*)2} |
| 0F232H | Port 6 control register 0 | P6CON0 | — | R/W | 8 | 00H |

^{(*)1} initial value for ML610407, ^{(*)2} initial value for ML610408

19.2.2 Port 6 Data Register (P6D)

Address: 0F230H
Access: R/W
Access size: 8-bit
Initial value: 0FFH

| | | | | | | | | |
|---------------|--------------------|--------------------|--------------------|--------------------|--------------------|--------------------|--------------------|--------------------|
| | 7 | 6 | 5 | 4 | 3 | 2 | 1 | 0 |
| P6D | P67D | P66D | P65D | P64D | P63D | P62D | P61D | P60D |
| R/W | R/W ^(*) | R/W ^(*) | R/W ^(*) | R/W ^(*) | R/W ^(*) | R/W ^(*) | R/W ^(*) | R/W ^(*) |
| Initial value | 1 ^(*) | 1 ^(*) | 1 ^(*) | 1 ^(*) | 1 ^(*) | 1 ^(*) | 1 ^(*) | 1 ^(*) |

P6D is a special function register (SFR) to set the output value of the Port 6 pins. The value of this register is output to Port 6. The value written to P6D is readable.

(*)For ML610Q408, P67D to P64D always returns the value "0".

ML610Q409 does not have this register, and P67D to P60D always returns the value "0".

[Description of Bits]

- **P67D to P60D** (bit 7 to 0)

The P67D to P60D bits are used to set the output value of the Port 6 pins.

| P67D | Description |
|------|----------------------------------|
| 0 | Output level of the P67 pin: "L" |
| 1 | Output level of the P67 pin: "H" |

| P66D | Description |
|------|----------------------------------|
| 0 | Output level of the P66 pin: "L" |
| 1 | Output level of the P66 pin: "H" |

| P65D | Description |
|------|----------------------------------|
| 0 | Output level of the P65 pin: "L" |
| 1 | Output level of the P65 pin: "H" |

| P64D | Description |
|------|----------------------------------|
| 0 | Output level of the P64 pin: "L" |
| 1 | Output level of the P64 pin: "H" |

| P63D | Description |
|------|----------------------------------|
| 0 | Output level of the P63 pin: "L" |
| 1 | Output level of the P63 pin: "H" |

| P62D | Description |
|------|----------------------------------|
| 0 | Output level of the P62 pin: "L" |
| 1 | Output level of the P62 pin: "H" |

| P61D | Description |
|------|----------------------------------|
| 0 | Output level of the P61 pin: "L" |
| 1 | Output level of the P61 pin: "H" |

| P60D | Description |
|------|----------------------------------|
| 0 | Output level of the P60 pin: "L" |
| 1 | Output level of the P60 pin: "H" |

19.2.3 Port 6 Control Register 0 (P6CON0)

Address: 0F232H
 Access: R/W
 Access size: 8-bit
 Initial value: 00H

| | | | | | | | | |
|---------------|-------|-------|-------|-------|-------|-------|-------|-------|
| | 7 | 6 | 5 | 4 | 3 | 2 | 1 | 0 |
| P6CON0 | P67C0 | P66C0 | P65C0 | P64C0 | P63C0 | P62C0 | P61C0 | P60C0 |
| R/W | R/W | R/W | R/W | R/W | R/W | R/W | R/W | R/W |
| Initial value | 0 | 0 | 0 | 0 | 0 | 0 | 0 | 0 |

P6CON0 is a special function registers (SFR) to select input/output state of the Port 6 pin.

For ML610408, P67C0 to P64C0 always returns the value “0”.

[Description of Bits]

- **P67C0 to P60C0** (bit 7 to 0)
 P67C0 to P60C0 are the bits that select either N-channel open drain output or CMOS output.

| P67C0 | Description |
|-------|---|
| 0 | N-channel open drain output (initial value) |
| 1 | CMOS output |

| P66C0 | Description |
|-------|---|
| 0 | N-channel open drain output (initial value) |
| 1 | CMOS output |

| P65C0 | Description |
|-------|---|
| 0 | N-channel open drain output (initial value) |
| 1 | CMOS output |

| P64C0 | Description |
|-------|---|
| 0 | N-channel open drain output (initial value) |
| 1 | CMOS output |

| P63C0 | Description |
|-------|---|
| 0 | N-channel open drain output (initial value) |
| 1 | CMOS output |

| P62C0 | Description |
|-------|---|
| 0 | N-channel open drain output (initial value) |
| 1 | CMOS output |

| P61C0 | Description |
|-------|---|
| 0 | N-channel open drain output (initial value) |
| 1 | CMOS output |

| P60C0 | Description |
|-------|---|
| 0 | N-channel open drain output (initial value) |
| 1 | CMOS output |

19.3 Description of Operation

19.3.1 Output Port Function

For each of the Port 6 pins, N-channel open drain output mode or CMOS output mode can be selected by setting the Port 6 control register 0 (P6CON0).

At the system reset, N-channel open drain output mode is selected as the initial state.

Depending on the value set in the Port 6 data register (P6D), a "L" level or "H" level signal is output to each pin of Port 6.

Melody Driver

20. Melody Driver

20.1 Overview

This LSI includes one channel of the melody driver.

To use the melody driver, the secondary function of Port 2 or Port 5 should be set. For the secondary function of Port 2, see Chapter 15, "Port 2". For the secondary function of Port 5, see Chapter 18, "Port 5". For the clock to be used in this block, see Chapter 6, "Clock Generation Circuit".

20.1.1 Features

- In melody output mode, 29 scales (melody audio frequency: 508Hz to 32.768kHz), 63 tone lengths, and 15 tempos) are available.
- In buzzer output mode, 4 output modes, 8 frequencies, and 15 duties can be set.

20.1.2 Configuration

Figure 20-1 shows the configuration of the melody driver.

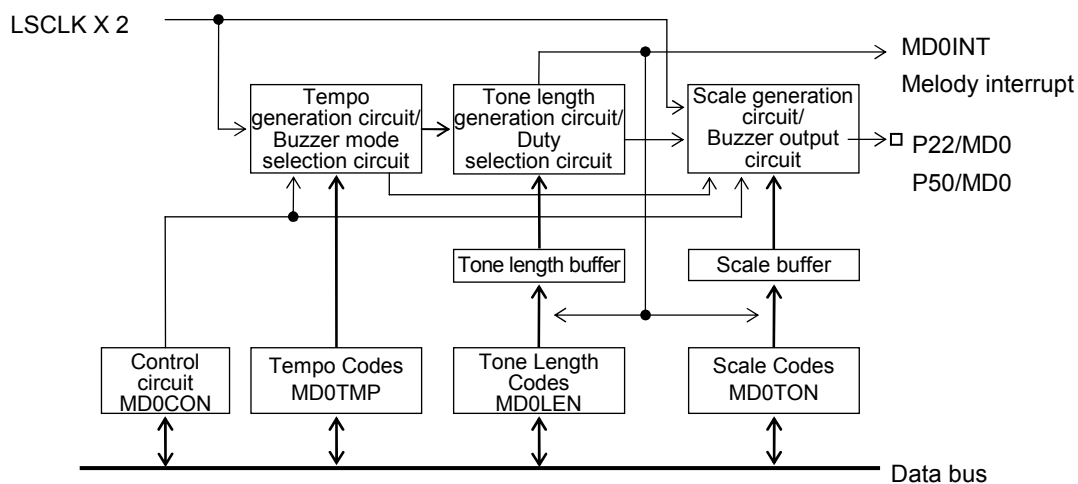

MD0CON : Melody 0 control register
 MD0TMP : Melody 0 tempo code register
 MD0TON : Melody 0 scale code register
 MD0LEN : Melody 0 tone length code register

Figure 20-1 Configuration of Melody Driver

20.1.3 List of Pins

| Pin name | I/O | Function |
|----------|-----|---|
| P22/MD0 | O | Melody 0 signal output pin Used as the secondary function of the P22 pin. |
| P50/MD0 | O | Melody 0 signal output pin Used for the secondary function of the P50 pin. |

20.2 Description of Registers

20.2.1 List of Registers

| Address | Name | Symbol (Byte) | Symbol (Word) | R/W | Size | Initial value |
|---------|------------------------------------|---------------|---------------|-----|------|---------------|
| 0F2C0H | Melody 0 control register | MD0CON | — | R/W | 8 | 00H |
| 0F2C1H | Melody 0 tempo code register | MD0TMP | — | R/W | 8 | 00H |
| 0F2C2H | Melody 0 scale code register | MD0TON | MD0TL | R/W | 8/16 | 00H |
| 0F2C3H | Melody 0 tone length code register | MD0LEN | | R/W | 8 | 00H |

20.2.2 Melody 0 Control Register (MD0CON)

Address: 0F2C0H
Access: R/W
Access size: 8-bit
Initial value: 00H

| | | | | | | | | |
|---------------|-----|-----|-----|-----|-----|-----|------|-------|
| | 7 | 6 | 5 | 4 | 3 | 2 | 1 | 0 |
| MD0CON | — | — | — | — | — | — | BZMD | M0RUN |
| R/W | R/W | R/W | R/W | R/W | R/W | R/W | R/W | R/W |
| Initial value | 0 | 0 | 0 | 0 | 0 | 0 | 0 | 0 |

MD0CON is a special function register (SFR) to control the melody and the buzzer.

[Description of Bits]

- **BZMD** (bit 1)
The BZMD bit is used to select melody mode or buzzer mode.

| BZMD | Description |
|------|-----------------------------|
| 0 | Melody mode (initial value) |
| 1 | Buzzer mode |

- **M0RUN** (bit 0)
The M0RUN bit is used to control start/stop of the MD0 output.

| M0RUN | Description |
|-------|-----------------------------------|
| 0 | Stops MD0 output. (Initial value) |
| 1 | Starts MD0 output. |

Note:

For melody output, use the low-speed double clock (LSCLK x 2).
Enable the low-speed double clock by setting bit 2 (ENMLT) of frequency control register 1 (FCON1) to “1” and then start melody output by setting M0RUN to “1”.

20.2.3 Melody 0 Tempo Code Register (MD0TMP)

Address: 0F2C1H
 Access: R/W
 Access size: 8-bit
 Initial value: 00H

| | | | | | | | | |
|---------------|-----|-----|-----|-----|-------|-------|-------|-------|
| | 7 | 6 | 5 | 4 | 3 | 2 | 1 | 0 |
| MD0TMP | — | — | — | — | M0TM3 | M0TM2 | M0TM1 | M0TM0 |
| R/W | R/W | R/W | R/W | R/W | R/W | R/W | R/W | R/W |
| Initial value | 0 | 0 | 0 | 0 | 0 | 0 | 0 | 0 |

MD0TMP is a special function register (SFR) to set the tempo code of a melody when melody mode is selected and the output mode of a buzzer sound waveform when buzzer mode is selected.

[Description of Bits]

- **M0TM3, M0TM2, M0TM1, M0TM0** (bits 3-0)

| When melody mode is selected (BZMD bit = "0") | | | | |
|---|-------|-------|-------|-------------------------|
| M0TM3 | M0TM2 | M0TM1 | M0TM0 | Description |
| 0 | 0 | 0 | 0 | ♪ = 480 (initial value) |
| 0 | 0 | 0 | 1 | ♪ = 480 |
| 0 | 0 | 1 | 0 | ♪ = 320 |
| 0 | 0 | 1 | 1 | ♪ = 240 |
| 0 | 1 | 0 | 0 | ♪ = 192 |
| 0 | 1 | 0 | 1 | ♪ = 160 |
| 0 | 1 | 1 | 0 | ♪ ≅ 137 |
| 0 | 1 | 1 | 1 | ♪ = 120 |
| 1 | 0 | 0 | 0 | ♪ ≅ 107 |
| 1 | 0 | 0 | 1 | ♪ = 96 |
| 1 | 0 | 1 | 0 | ♪ ≅ 87 |
| 1 | 0 | 1 | 1 | ♪ = 80 |
| 1 | 1 | 0 | 0 | ♪ ≅ 74 |
| 1 | 1 | 0 | 1 | ♪ ≅ 69 |
| 1 | 1 | 1 | 0 | ♪ = 64 |
| 1 | 1 | 1 | 1 | ♪ = 60 |

| When buzzer mode is selected (BZMD bit = "1") | | | | |
|---|-------|-------|-------|---|
| M0TM3 | M0TM2 | M0TM1 | M0TM0 | Description |
| * | * | 0 | 0 | Intermittent sound 1 output (initial value) |
| * | * | 0 | 1 | Intermittent sound 2 output |
| * | * | 1 | 0 | Single sound output |
| * | * | 1 | 1 | Continuous sound output |

20.2.4 Melody 0 Scale Code Register (MD0TON)

Address: 0F2C2H
Access: R/W
Access size: 8-bit
Initial value: 00H

| | | | | | | | | |
|---------------|-----|-------|-------|-------|-------|-------|-------|-------|
| | 7 | 6 | 5 | 4 | 3 | 2 | 1 | 0 |
| MD0TON | — | M0TN6 | M0TN5 | M0TN4 | M0TN3 | M0TN2 | M0TN1 | M0TN0 |
| R/W | R/W | R/W | R/W | R/W | R/W | R/W | R/W | R/W |
| Initial value | 0 | 0 | 0 | 0 | 0 | 0 | 0 | 0 |

MD0TON is a special function register (SFR) to set the scale code of a melody when melody mode is selected and a buzzer output frequency when buzzer mode is selected.

[Description of Bits]

- **M0TN6, M0TN5, M0TN4, M0TN3, M0TN2, M0TN1, M0TN0** (bits 6-0)

| | |
|---|------------------------------------|
| When melody mode is selected (BZMD bit = "0") | |
| M0TN6~0 | Description |
| | Sets the corresponding scale code. |

For scale codes, see Section 20.3.4, "Scale Codes".

| When buzzer mode is selected (BZMD bit = "1") | | | | |
|---|--------------|--------------|--------------|---------------------------|
| M0TN6~3 | M0TN2 | M0TN1 | M0TN0 | Description |
| * | 0 | 0 | 0 | 4.096 kHz (initial value) |
| * | 0 | 0 | 1 | 2.048kHz |
| * | 0 | 1 | 0 | 1.365kHz |
| * | 0 | 1 | 1 | 1.024kHz |
| * | 1 | 0 | 0 | 819Hz |
| * | 1 | 0 | 1 | 683Hz |
| * | 1 | 1 | 0 | 585Hz |
| * | 1 | 1 | 1 | 512Hz |

Note: In buzzer mode, the M0TN6 to M0TN3 bits are not used (Don't care).

20.2.5 Melody 0 Tone Length Code Register (MD0LEN)

Address: 0F2C3H
 Access: R/W
 Access size: 8-bit
 Initial value: 00H

| | | | | | | | | |
|---------------|-----|-----|-------|-------|-------|-------|-------|-------|
| | 7 | 6 | 5 | 4 | 3 | 2 | 1 | 0 |
| MD0LEN | — | — | M0LN5 | M0LN4 | M0LN3 | M0LN2 | M0LN1 | M0LN0 |
| R/W | R/W | R/W | R/W | R/W | R/W | R/W | R/W | R/W |
| Initial value | 0 | 0 | 0 | 0 | 0 | 0 | 0 | 0 |

MD0LEN is a special function register (SFR) to set the tone length code of a melody when melody mode is selected and buzzer output duty when buzzer mode is selected.

[Description of Bits]

- **M0LN5, M0LN4, M0LN3, M0LN2, M0LN1, M0LN0** (bits 5-0)

| | |
|---|--|
| When melody mode is selected (BZMD bit = "0") | |
| M0LN5~0 | Description |
| | Sets the corresponding tone length code. |

For tone length codes, see Section 20.3.3, "Tone Length Codes".

| When buzzer mode is selected (BZMD bit = "1") | | | | | |
|---|--------------|--------------|--------------|--------------|---------------------------|
| M0LN5~4 | M0LN3 | M0LN2 | M0LN1 | M0LN0 | Description |
| * | 0 | 0 | 0 | 0 | 1/16 DUTY (initial value) |
| * | 0 | 0 | 0 | 1 | 1/16DUTY |
| * | 0 | 0 | 1 | 0 | 2/16DUTY |
| * | 0 | 0 | 1 | 1 | 3/16DUTY |
| * | 0 | 1 | 0 | 0 | 4/16DUTY |
| * | 0 | 1 | 0 | 1 | 5/16DUTY |
| * | 0 | 1 | 1 | 0 | 6/16DUTY |
| * | 0 | 1 | 1 | 1 | 7/16DUTY |
| * | 1 | 0 | 0 | 0 | 8/16DUTY |
| * | 1 | 0 | 0 | 1 | 9/16DUTY |
| * | 1 | 0 | 1 | 0 | 10/16DUTY |
| * | 1 | 0 | 1 | 1 | 11/16DUTY |
| * | 1 | 1 | 0 | 0 | 12/16DUTY |
| * | 1 | 1 | 0 | 1 | 13/16DUTY |
| * | 1 | 1 | 1 | 0 | 14/16DUTY |
| * | 1 | 1 | 1 | 1 | 15/16DUTY |

Note: In buzzer mode, the M0LN5 to M0LN4 bits are not used (Don't care).

20.3 Description of Operation

20.3.1 Operation of Melody Output

Melody is output in the following procedure.

- (1) Select melody mode by setting the BZMD bit of the melody 0 control register (MD0CON) to "0".
- (2) Set a melody tempo in the melody 0 tempo code register (MD0TMP).
- (3) Set a tone length code in the melody 0 tone length code register (MD0LEN).
- (4) Set a scale code in the melody 0 scale code register (MD0TON).
- (5) Set bit 2 (ENMLT) of the frequency control register 1 (FCON1) to "1" to enable the low-speed double clock.
- (6) When the MORUN bit of the melody 0 control register (MD0CON) is set to "1", the tone length code and scale code are transferred to the tone length buffer and scale buffer and melody output is started from the MD0 pin. At the same time, a melody 0 interrupt (MD0INT) is requested. When an interrupt occurs and program is passed to the interrupt routine, the interrupt request flag is cleared.

The melody 0 signal output pin (MD0) is assigned as the secondary function of Port 2 or Port 5. For the secondary function of Port 2 or Port 5, see Chapter 15, "Port 2" or Chapter 18, "Port 5".

In the software processing after melody 0 interrupt, the tone length code and the scale code of the note that are output next are set to MD0LEN and MD0TON, respectively. When there is no next note to be output, rest data "00H" is set in MD0TON, the MORUN bit is set to "0" by the software processing after the next melody 0 interrupt, and melody output is terminated.

By setting the MORUN bit to "0", melody can be terminated forcibly during melody output.

Figure 20-2 shows the operation waveform of the melody driver.

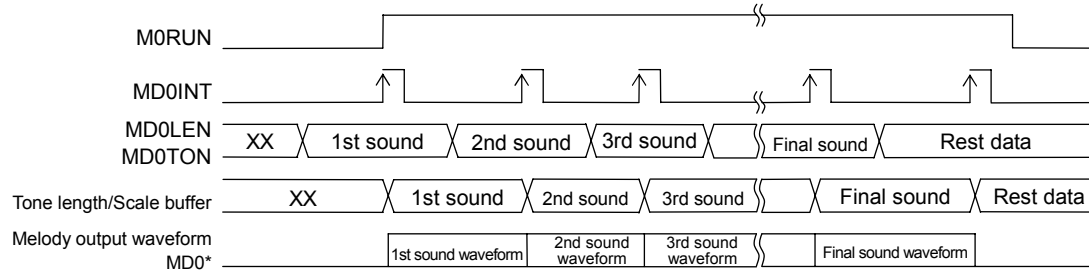

Figure 20-2 Operation Waveform of Melody Driver

















20.3.2 Tempo Codes

A tempo code is set in the melody 0 tempo code register (MD0TEM).

Table 20-1 shows the correspondence between tempos (number of counts for one minute) and tempo codes.

The tempo when all the bits are set to "0" is equal to the shortest tone length (the tempo when the only M0TP0 bit is set to "1").

Table 20-1 Correspondence between Tempos and Tempo Codes

| Tempo | Tempo code (MD0TMP) | | | | |
|---|---------------------|-------|-------|-------|---------|
| | M0TP3 | M0TP2 | M0TP1 | M0TP0 | M0TP3~0 |
|  = 480 | 0 | 0 | 0 | 0 | 0H |
|  = 480 | 0 | 0 | 0 | 1 | 1H |
|  = 320 | 0 | 0 | 1 | 0 | 2H |
|  = 240 | 0 | 0 | 1 | 1 | 3H |
|  = 192 | 0 | 1 | 0 | 0 | 4H |
|  = 160 | 0 | 1 | 0 | 1 | 5H |
|  ≅ 137 | 0 | 1 | 1 | 0 | 6H |
|  = 120 | 0 | 1 | 1 | 1 | 7H |
|  ≅ 107 | 1 | 0 | 0 | 0 | 8H |
|  = 96 | 1 | 0 | 0 | 1 | 9H |
|  ≅ 87 | 1 | 0 | 1 | 0 | AH |
|  = 80 | 1 | 0 | 1 | 1 | BH |
|  ≅ 74 | 1 | 1 | 0 | 0 | CH |
|  ≅ 69 | 1 | 1 | 0 | 1 | DH |
|  = 64 | 1 | 1 | 1 | 0 | EH |
|  = 60 | 1 | 1 | 1 | 1 | FH |











20.3.3 Tone Length Codes

A tone length code is set in the melody 0 tone length code register (MDOLEN).

Table 20-2 shows the correspondence between tone lengths and tone length codes.

The tone length when all the bits are set to "0" is equal to the shortest tone length (the tone length when the only M0LN0 bit is set to "1").

Table 20-2 Correspondence between Tone Lengths and Tone Length Codes

| Tone length | Tone length code (MDOLEN) | | | | | | |
|---|---------------------------|-------|-------|-------|-------|-------|---------|
| | M0LN5 | M0LN4 | M0LN3 | M0LN2 | M0LN1 | M0LN1 | M0LN5~0 |
|  | 1 | 1 | 1 | 1 | 1 | 1 | 3FH |
|  | 1 | 0 | 1 | 1 | 1 | 1 | 2FH |
|  | 0 | 1 | 1 | 1 | 1 | 1 | 1FH |
|  | 0 | 1 | 0 | 1 | 1 | 1 | 17H |
|  | 0 | 0 | 1 | 1 | 1 | 1 | 0FH |
|  | 0 | 0 | 1 | 0 | 1 | 1 | 0BH |
|  | 0 | 0 | 0 | 1 | 1 | 1 | 07H |
|  | 0 | 0 | 0 | 1 | 0 | 1 | 05H |
|  | 0 | 0 | 0 | 0 | 1 | 1 | 03H |
|  | 0 | 0 | 0 | 0 | 1 | 0 | 02H |
|  | 0 | 0 | 0 | 0 | 0 | 1 | 01H |

The tone length set by a tone length code and a tempo code is expressed by the following equation.

Tone length = $1.953125 \times (TP + 1) \times (LN + 1)$ ms where TP is an integer of 1 to 15, and LN is an integer of 1 to 63.

The bit correspondence between TP and tempo codes is expressed by the following equation.

$$TP = 2^3M0TP3 + 2^2M0TP2 + 2^1M0TP1 + 2^0M0TP0$$

The bit correspondence between LN and tone length codes is expressed by the following equation.

$$LN = 2^5M0LN5 + 2^4M0LN4 + 2^3M0LN3 + 2^2M0LN2 + 2^1M0LN1 + 2^0M0LN0$$

20.3.4 Scale Codes

A scale code is set in the melody 0 scale code register (MD0TON).

In the melody driver, a frequency that can be output is expressed by the following equation.

$$\frac{65536}{(TN + 1)} \text{ Hz} \quad (\text{where } TN \text{ is an integer of } 4 \text{ to } 127.)$$

The bit correspondence between TN and scale codes is expressed by the following equation.

$$TN = 2^6M0TN6 + 2^5M0TN5 + 2^4M0TN4 + 2^3M0TN3 + 2^2M0TN2 + 2^1M0TN1 + 2^0M0TN0$$

Table 20-3 shows the correspondence between scales and scale codes.

When the M0TN6 to M0TN2 bits are set to "0", scale becomes a rest. The rest length is set by the tone length code (MD0LEN).

Table 20-3 Correspondence between Scales and Scale Codes

| Scale | Frequency (Hz) | Scale code (MD0TON) | | | | | | | |
|------------------|----------------|---------------------|-------|-------|-------|-------|-------|-------|---------|
| | | M0TN6 | M0TN5 | M0TN4 | M0TN3 | M0TN2 | M0TN1 | M0TN0 | M0TN6-0 |
| C ¹ | 529 | 1 | 1 | 1 | 1 | 0 | 1 | 1 | 7BH |
| Cis ¹ | 560 | 1 | 1 | 1 | 0 | 1 | 0 | 0 | 74H |
| D ¹ | 590 | 1 | 1 | 0 | 1 | 1 | 1 | 0 | 6EH |
| Dis ¹ | 624 | 1 | 1 | 0 | 1 | 0 | 0 | 0 | 68H |
| E ¹ | 662 | 1 | 1 | 0 | 0 | 0 | 1 | 0 | 62H |
| F ¹ | 705 | 1 | 0 | 1 | 1 | 1 | 0 | 0 | 5CH |
| Fis ¹ | 745 | 1 | 0 | 1 | 0 | 1 | 1 | 1 | 57H |
| G ¹ | 790 | 1 | 0 | 1 | 0 | 0 | 1 | 0 | 52H |
| Gis ¹ | 840 | 1 | 0 | 0 | 1 | 1 | 0 | 1 | 4DH |
| A ¹ | 886 | 1 | 0 | 0 | 1 | 0 | 0 | 1 | 49H |
| Ais ¹ | 936 | 1 | 0 | 0 | 0 | 1 | 0 | 1 | 45H |
| B ¹ | 993 | 1 | 0 | 0 | 0 | 0 | 0 | 1 | 41H |
| C ² | 1057 | 0 | 1 | 1 | 1 | 1 | 0 | 1 | 3DH |
| Cis ² | 1111 | 0 | 1 | 1 | 1 | 0 | 1 | 0 | 3AH |
| D ² | 1192 | 0 | 1 | 1 | 0 | 1 | 1 | 0 | 36H |
| Dis ² | 1260 | 0 | 1 | 1 | 0 | 0 | 1 | 1 | 33H |
| E ² | 1338 | 0 | 1 | 1 | 0 | 0 | 0 | 0 | 30H |
| F ² | 1394 | 0 | 1 | 0 | 1 | 1 | 1 | 0 | 2EH |
| Fis ² | 1490 | 0 | 1 | 0 | 1 | 0 | 1 | 1 | 2BH |
| G ² | 1560 | 0 | 1 | 0 | 1 | 0 | 0 | 1 | 29H |
| Gis ² | 1680 | 0 | 1 | 0 | 0 | 1 | 1 | 0 | 26H |
| A ² | 1771 | 0 | 1 | 0 | 0 | 1 | 0 | 0 | 24H |
| Ais ² | 1872 | 0 | 1 | 0 | 0 | 0 | 1 | 0 | 22H |
| B ² | 1986 | 0 | 1 | 0 | 0 | 0 | 0 | 0 | 20H |
| C ³ | 2114 | 0 | 0 | 1 | 1 | 1 | 1 | 0 | 1EH |
| D ³ | 2341 | 0 | 0 | 1 | 1 | 0 | 1 | 1 | 1BH |
| Dis ³ | 2521 | 0 | 0 | 1 | 1 | 0 | 0 | 1 | 19H |
| E ³ | 2621 | 0 | 0 | 1 | 1 | 0 | 0 | 0 | 18H |
| Fis ³ | 2979 | 0 | 0 | 1 | 0 | 1 | 0 | 1 | 15H |

20.3.5 Example of Using Melody Circuit

Figure 20-3 shows an example of a melody notation, and Table 20-4 shows note codes of melody examples.



Figure 20-3 Example of Melody Notation

Table 20-4 Note Codes of Melody Examples

| Note | Note code | | | | | | | | | | | | | | Hexadecimal |
|----------------|-----------|---|---|---|---|---|--------|---|---|---|---|---|---|-------|-------------|
| | MD0LEN | | | | | | MD0TON | | | | | | | | |
| | 5 | 4 | 3 | 2 | 1 | 0 | 6 | 5 | 4 | 3 | 2 | 1 | 0 | | |
| G ² | 1 | 0 | 1 | 1 | 1 | 1 | 0 | 1 | 0 | 1 | 0 | 0 | 0 | 2F28H | |
| D ² | 0 | 0 | 1 | 1 | 1 | 1 | 0 | 1 | 1 | 0 | 1 | 0 | 1 | 0F35H | |
| G ² | 0 | 0 | 1 | 1 | 1 | 1 | 0 | 1 | 0 | 1 | 0 | 0 | 0 | 0F28H | |
| — | 0 | 0 | 0 | 1 | 1 | 1 | 0 | 0 | 0 | 0 | 0 | 0 | 0 | 0700H | |
| D ² | 0 | 0 | 0 | 1 | 1 | 1 | 0 | 1 | 1 | 0 | 1 | 0 | 1 | 0735H | |
| G ² | 0 | 0 | 1 | 1 | 1 | 1 | 0 | 1 | 0 | 1 | 0 | 0 | 0 | 0F28H | |
| — | 0 | 0 | 0 | 1 | 1 | 1 | 0 | 0 | 0 | 0 | 0 | 0 | 0 | 0700H | |
| A ² | 0 | 0 | 0 | 1 | 1 | 1 | 0 | 1 | 0 | 0 | 0 | 1 | 1 | 0723H | |
| B ² | 1 | 1 | 1 | 1 | 1 | 1 | 0 | 0 | 1 | 1 | 1 | 1 | 1 | 3F1FH | |
| G ² | 1 | 1 | 1 | 1 | 1 | 1 | 0 | 1 | 0 | 1 | 0 | 0 | 0 | 3F28H | |

20.3.6 Operations of Buzzer Output

A buzzer sound is output in the following procedure.

- (1) Select a buzzer mode by setting the BZMD bit of the melody 0 control register (MD0CON) to "1".
- (2) Select a buzzer output mode using the melody 0 tempo code register (MD0TMP).
- (3) Select a duty of the High level width of the buzzer output waveform using the melody 0 tone length code register (MD0LEN).
- (4) Set the buzzer output frequency in the melody 0 scale code register (MD0TON).
- (5) Set bit 2 (ENMLT) of the frequency control register 1 (FCON1) to "1" to enable the low-speed double clock.
- (6) When the M0RUN bit of the melody 0 control register (MD0CON) is set to "1", the waveform equivalent to the buzzer sound that is set from the MD0 pin is output.

Figure 20-4 shows the output waveform of each buzzer output mode.

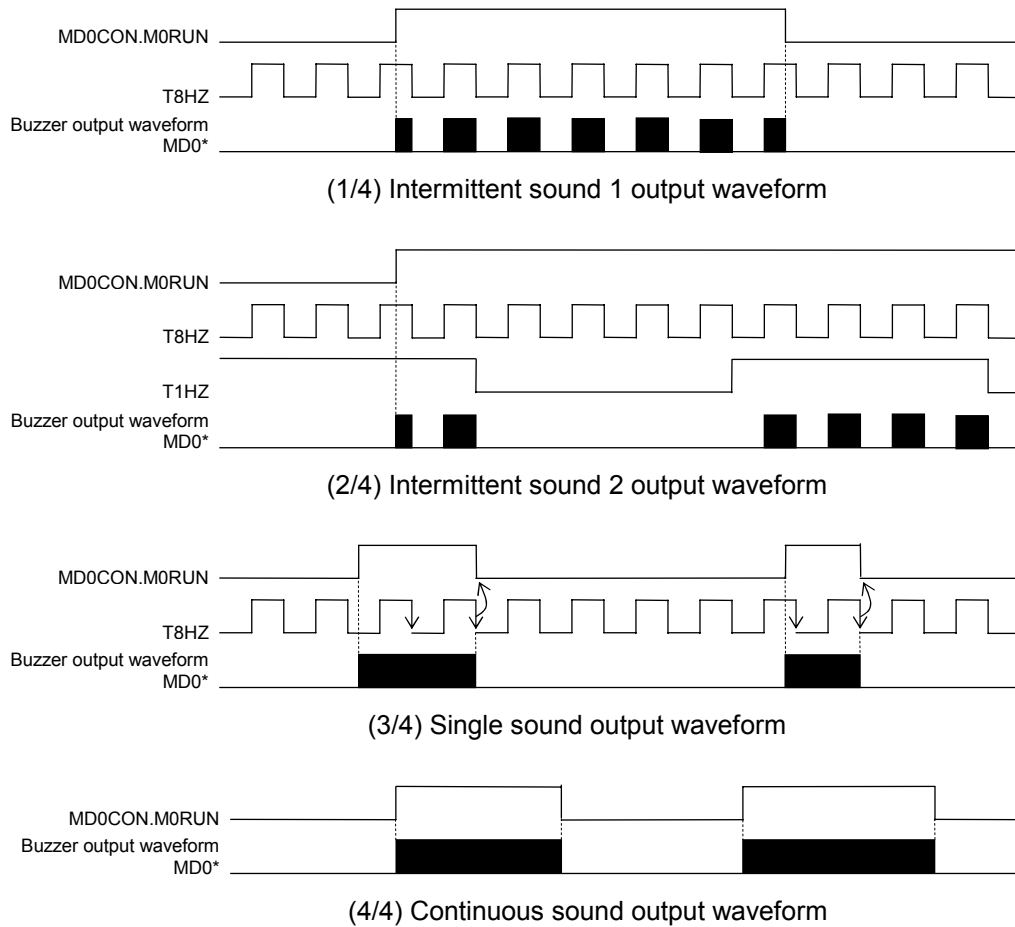

Figure 20-4 Output Waveform of Each Buzzer Output Mode

20.4 Specifying Port Registers

To enable the melody or buzzer function, the applicable bit of each related port register needs to be set. See Chapter 15, "Port 2" for detail about the port registers.

20.4.1 Functioning P22 Pin (MD0: Output) as the Melody or Buzzer Output

Set the P22MD bit (P2MOD register bit 2) to "1" for selecting the melody or buzzer output as the secondary function of the P22.

| Register name | P2MOD register (Address: 0F214H) | | | | | | | |
|---------------|----------------------------------|---|---|---|---|--------------|-------|-------|
| Bit | 7 | 6 | 5 | 4 | 3 | 2 | 1 | 0 |
| Bit name | - | - | - | - | - | P22MD | P21MD | P20MD |
| Setting value | - | - | - | - | - | 1 | * | * |

Set the P22C1 bit (P2CON1 register bit 2) to "1" and the P22C0 bit (P2CON0 register bit 2) to "1" for selecting the P22 pin state mode to CMOS output.

| Register name | P2CON1 register (Address: 0F213H) | | | | | | | |
|---------------|-----------------------------------|---|---|---|---|--------------|-------|-------|
| Bit | 7 | 6 | 5 | 4 | 3 | 2 | 1 | 0 |
| Bit name | - | - | - | - | - | P22C1 | P21C1 | P20C1 |
| Setting value | - | - | - | - | - | 1 | * | * |

| Register name | P2CON0 register (Address: 0F212H) | | | | | | | |
|---------------|-----------------------------------|---|---|---|---|--------------|-------|-------|
| Bit | 7 | 6 | 5 | 4 | 3 | 2 | 1 | 0 |
| Bit name | - | - | - | - | - | P22C0 | P21C0 | P20C0 |
| Setting value | - | - | - | - | - | 1 | * | * |

Data of P22D bit (P2D register bit2) does not affect to the melody or buzzer function, so don't care the data for the function.

| Register name | P2D register (Address: 0F210H) | | | | | | | |
|---------------|--------------------------------|---|---|---|---|-------------|------|------|
| Bit | 7 | 6 | 5 | 4 | 3 | 2 | 1 | 0 |
| Bit name | - | - | - | - | - | P22D | P21D | P20D |
| Setting value | - | - | - | - | - | ** | * | * |

- : Bit that does not exist

* : Bit not related to the Melody function

** : Don't care

Note:

- P2 (Port 2) is an output-only pin and does not have the register to select the data direction(input or output).
- The P22 pin output characteristics are VOL1 and VOH1 (described in Appendix C, "Electrical Characteristics") when the P22MD bit is "1" (melody/buzzer is selected as the secondary function), and VOL2 and VOH2 when the bit is "0".

20.4.2 Functioning P50 Pin (MD0: Output) as the Melody or Buzzer Output

Set the P50MD1 bit (P5MOD1 register bit 0) to “0” and the P50MD0 bit (P5MOD0 register bit 0) to “1” for selecting the melody or buzzer output as the secondary function of the P50.

| Register name | P5MOD1 register (address: 0F22DH) | | | | | | | |
|---------------|-----------------------------------|--------|--------|--------|---|--------|--------|---------------|
| Bit | 7 | 6 | 5 | 4 | 3 | 2 | 1 | 0 |
| Bit name | - | P56MD1 | P55MD1 | P54MD1 | - | P52MD1 | P51MD1 | P50MD1 |
| Setting value | - | * | * | * | * | * | * | 1 |

| Register name | P5MOD0 register (address: 0F22CH) | | | | | | | |
|---------------|-----------------------------------|--------|--------|--------|---|--------|--------|---------------|
| Bit | 7 | 6 | 5 | 4 | 3 | 2 | 1 | 0 |
| Bit name | - | P56MD0 | P55MD0 | P54MD0 | - | P52MD0 | P51MD0 | P50MD0 |
| Setting value | - | * | * | * | * | * | * | 1 |

Set the the P50C0 bit (P5CON0 register bit 0) to “1” for selecting the P50 pin state mode to CMOS output. Set the P50DIR bit (P5DIR register bit 0) to “0” for selecting the P50 as an output pin. The P5UD bit (P5CON1 register bit 0) data can either be "0" or "1".

| Register name | P5CON1 register (address: 0F22BH) | | | | | | | |
|---------------|-----------------------------------|---|---|---|---|---|---|-------------|
| Bit | 7 | 6 | 5 | 4 | 3 | 2 | 1 | 0 |
| Bit name | - | - | - | - | - | - | - | P5UD |
| Setting value | - | - | - | - | - | - | - | * |

| Register name | P5CON0 register (address: 0F22AH) | | | | | | | |
|---------------|-----------------------------------|-------|-------|-------|-------|-------|-------|--------------|
| Bit | 7 | 6 | 5 | 4 | 3 | 2 | 1 | 0 |
| Bit name | P57C0 | P56C0 | P55C0 | P54C0 | P53C0 | P52C0 | P51C0 | P50C0 |
| Setting value | * | * | * | * | * | * | * | 1 |

| Register name | P5DIR register (address: 0F229H) | | | | | | | |
|---------------|----------------------------------|--------|--------|--------|--------|--------|--------|---------------|
| Bit | 7 | 6 | 5 | 4 | 3 | 2 | 1 | 0 |
| Bit name | P57DIR | P56DIR | P55DIR | P54DIR | P53DIR | P52DIR | P51DIR | P50DIR |
| Setting value | * | * | * | * | * | * | * | 0 |

The P50D bit (P5D register bit 0) data can either be "0" or "1".

| Register name | P5D register (address: 0F228H) | | | | | | | |
|---------------|--------------------------------|------|------|------|------|------|------|------|
| Bit | 7 | 6 | 5 | 4 | 3 | 2 | 1 | 0 |
| Bit name | P57D | P56D | P55D | P54D | P53D | P52D | P51D | P50D |
| Setting value | - | - | - | - | * | * | * | ** |

- : Bit that does not exist

* : Bit not related to the Melody function

** : Don't care

RC Oscillation Type A/D Converter

21. RC Oscillation Type A/D Converter

21.1 Overview

This LSI has a built-in 2-channel RC oscillation type A/D converter (RC-ADC).

The RC-ADC converts resistance values or capacitance values to digital values by counting the oscillator clock whose frequency changes according to the resistor or capacitor connected to the RC oscillator circuits. By using a thermistor or humidity sensor as a resistor, a thermometer or hygrometer can be formed.

In addition, a different sensor for each of the two channels of RC-ADC's RC oscillator circuit can be used to broaden RC-ADC applications; for example, the converter can be used for expansion of measurement range or measurement at two points.

For input clocks, see Chapter 6, "Clock Generation Circuit".

21.1.1 Features

- 2-channel system by time division

21.1.2 Configuration

The RC-ADC consists of two RC oscillator circuits to form two channels, Counter A (RADCA0 and RADCA1) and Counter B (RADCB0 and RADCB1) as 16-bit binary counters, and an RC-ADC control circuit (RADCON, RADMOD). Figure 21-1 shows the configuration of the RC-ADC.

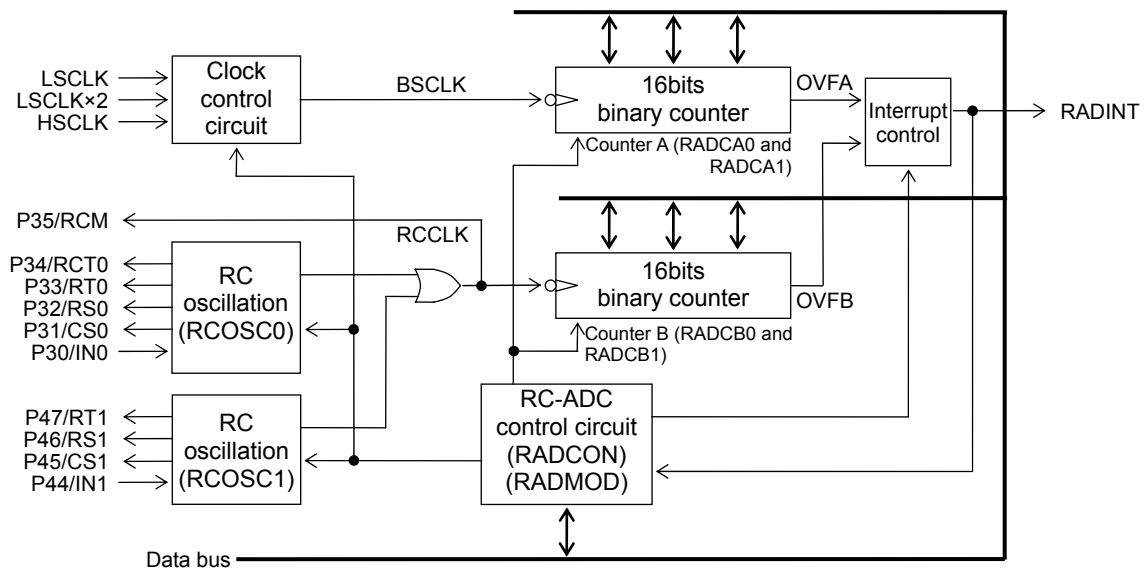

RADMOD : RC-ADC mode register
 RADCON : RC-ADC control register
 RADCA0~1 : RC-ADC Counter A register
 RADCB0~1 : RC-ADC Counter B register

Figure 21-1 Configuration of RC-ADC

21.1.3 List of Pins

| Pin name | I/O | Function |
|----------|-----|--|
| P30/IN0 | I | Channel 0 oscillation input pin. Used for the secondary function of the P30 pin. |
| P31/CS0 | O | Channel 0 reference capacitor connection pin. Used for the secondary function of the P31 pin. |
| P32/RS0 | O | Channel 0 reference resistor connection pin. Used for the secondary function of the P32 pin. |
| P33/RT0 | O | Pin for connection with a resistive sensor for measurement on Channel 0. Used for the secondary function of the P33 pin. |
| P34/RCT0 | O | Pin for connection with a resistive/capacitive sensor for measurement on Channel 0. Used for the secondary function of the P34 pin. |
| P35/RCM | O | RC oscillation monitor pin. Used for the secondary function of the P35 pin. |
| P44/IN1 | I | Channel 1 oscillation input pin. Used for the secondary function of the P44 pin. |
| P45/CS1 | O | Channel 1 reference capacitor connection pin. Used for the secondary function of the P45 pin. |
| P46/RS1 | O | Channel 1 reference resistor connection pin. Used for the secondary function of the P46 pin. |
| P47/RT1 | O | Pin for connection with a resistive sensor for measurement on Channel 1. Used for the secondary function of the P47 pin. |

21.2 Description of Registers

21.2.1 List of Registers

| Address | Name | Symbol(Byte) | Symbol (Word) | R/W | Size | Initial value |
|---------|-----------------------------|--------------|---------------|-----|------|---------------|
| 0F300H | RC-ADC Counter A register 0 | RADCA0 | — | R/W | 8 | 00H |
| 0F301H | RC-ADC Counter A register 1 | RADCA1 | — | R/W | 8 | 00H |
| 0F304H | RC-ADC Counter B register 0 | RADCB0 | — | R/W | 8 | 00H |
| 0F305H | RC-ADC Counter B register 1 | RADCB1 | — | R/W | 8 | 00H |
| 0F308H | RC-ADC mode register | RADMOD | — | R/W | 8 | 00H |
| 0F309H | RC-ADC control register | RADCON | — | R/W | 8 | 00H |

21.2.2 RC-ADC Counter A Registers (RADCA0–1)

Address: 0F300H
 Access: R/W
 Access size: 8-bit
 Initial value: 00H

| | | | | | | | | |
|---------------|------|------|------|------|------|------|------|------|
| | 7 | 6 | 5 | 4 | 3 | 2 | 1 | 0 |
| RADCA0 | RAA7 | RAA6 | RAA5 | RAA4 | RAA3 | RAA2 | RAA1 | RAA0 |
| R/W | R/W | R/W | R/W | R/W | R/W | R/W | R/W | R/W |
| Initial value | 0 | 0 | 0 | 0 | 0 | 0 | 0 | 0 |

Address: 0F301H
 Access: R/W
 Access size: 8-bit
 Initial value: 00H

| | | | | | | | | |
|---------------|-------|-------|-------|-------|-------|-------|------|------|
| | 7 | 6 | 5 | 4 | 3 | 2 | 1 | 0 |
| RADCA1 | RAA15 | RAA14 | RAA13 | RAA12 | RAA11 | RAA10 | RAA9 | RAA8 |
| R/W | R/W | R/W | R/W | R/W | R/W | R/W | R/W | R/W |
| Initial value | 0 | 0 | 0 | 0 | 0 | 0 | 0 | 0 |

RADCA0 and RADCA1 are special function registers (SFRs) for reading from and writing to the Counter A of the RC-ADC. RADCA0 and RADCA1 are 16-bit binary counters.

Note:

After writing data into the RC-ADC counter A register, be sure to read it to check that the data has been written correctly.

When A/D conversion starts after data is written, the value that has been written is read during A/D conversion (RARUN = 1).

When A/D conversion terminates (RARUN = 0), the count value is read.

21.2.3 RC-ADC Counter B Registers (RADCB0–1)

Address: 0F304H
 Access: R/W
 Access size: 8-bit
 Initial value: 00H

| | | | | | | | | |
|---------------|------|------|------|------|------|------|------|------|
| | 7 | 6 | 5 | 4 | 3 | 2 | 1 | 0 |
| RADCB0 | RAB7 | RAB6 | RAB5 | RAB4 | RAB3 | RAB2 | RAB1 | RAB0 |
| R/W | R/W | R/W | R/W | R/W | R/W | R/W | R/W | R/W |
| Initial value | 0 | 0 | 0 | 0 | 0 | 0 | 0 | 0 |

Address: 0F305H
 Access: R/W
 Access size: 8-bit
 Initial value: 00H

| | | | | | | | | |
|---------------|-------|-------|-------|-------|-------|-------|------|------|
| | 7 | 6 | 5 | 4 | 3 | 2 | 1 | 0 |
| RADCB1 | RAB15 | RAB14 | RAB13 | RAB12 | RAB11 | RAB10 | RAB9 | RAB8 |
| R/W | R/W | R/W | R/W | R/W | R/W | R/W | R/W | R/W |
| Initial value | 0 | 0 | 0 | 0 | 0 | 0 | 0 | 0 |

RADCB0 and RADCB1 are special function registers (SFRs) for reading from and writing to the Counter B of the RC-ADC. RADCB0 and RADCB1 are 16-bit binary counters.

Note:

After writing data into the RC-ADC counter B register, be sure to read it to check that the data has been written correctly.

When A/D conversion starts after data is written, the value that has been written is read during A/D conversion (RARUN = 1).

When A/D conversion terminates (RARUN = 0), the count value is read.

21.2.4 RC-ADC Mode Register (RADMOD)

Address: 0F308H
 Access: R/W
 Access size: 8-bit
 Initial value: 00H

| | | | | | | | | |
|---------------|-------|-------|-------|------|-----|-----|-----|-----|
| | 7 | 6 | 5 | 4 | 3 | 2 | 1 | 0 |
| RADMOD | RACK2 | RACK1 | RACK0 | RADI | OM3 | OM2 | OM1 | OM0 |
| R/W | R/W | R/W | R/W | R/W | R/W | R/W | R/W | R/W |
| Initial value | 0 | 0 | 0 | 0 | 0 | 0 | 0 | 0 |

RADMOD is a special function register (SFR) used to select the A/D conversion mode of the RC-ADC.

[Description of Bits]

- **OM3-0** (bits 3 to 0)

The OM3–0 bits are used to select an oscillation mode for the RC oscillator circuits.

| OM3 | OM2 | OM1 | OM0 | Description |
|-----|-----|-----|-----|---|
| 0 | 0 | 0 | 0 | IN0 pin external clock input mode (initial value) |
| 0 | 0 | 0 | 1 | RS0-CS0 oscillation mode |
| 0 | 0 | 1 | 0 | RT0-CS0 oscillation mode |
| 0 | 0 | 1 | 1 | RT ₀₋₁ -CS0 oscillation mode |
| 0 | 1 | 0 | 0 | RS0-CT0 oscillation mode |
| 0 | 1 | 0 | 1 | RS1-CS1 oscillation mode |
| 0 | 1 | 1 | 0 | RT1-CS1 oscillation mode |
| 0 | 1 | 1 | 1 | IN1 pin external clock input mode |
| 1 | * | * | * | Prohibited |

- **RADI** (bit 4)

The RADI bit is used to choose whether to generate the RC-ADC interrupt request signal (RADINT) by an overflow at Counter A or Counter B.

| RADI | Description |
|------|---|
| 0 | Generates an interrupt request by Counter A overflow (initial value). |
| 1 | Generates an interrupt request by Counter B overflow. |

- **RACK2-0** (bits 7 to 5)

The RACK2 to RACK0 bits are used to select the base clock of Counter A (BSCLK).

| RACK2 | RACK1 | RACK0 | Description |
|-------|-------|-------|---|
| 0 | 0 | 0 | LSCLK (initial value) |
| 0 | 0 | 1 | LSCLK×2 |
| 0 | 1 | 0 | HSCLK |
| 0 | 1 | 1 | 1/2HSCLK |
| 1 | 0 | 0 | 1/4HSCLK |
| 1 | 0 | 1 | 1/8HSCLK |
| 1 | 1 | * | Setting prohibited (no clock is supplied) |

Note:

When specifying LSCLK x 2 for the base clock, enable the operation of the low-speed double clock by setting bit 2 (ENMLT) of the frequency control register 1 (FCON1) to “1”.

21.2.5 RC-ADC Control Register (RADCON)

Address: 0F309H
 Access: R/W
 Access size: 8-bit
 Initial value: 00H

| | | | | | | | | |
|---------------|-----|-----|-----|-----|-----|-----|-----|-------|
| | 7 | 6 | 5 | 4 | 3 | 2 | 1 | 0 |
| RADCON | — | — | — | — | — | — | — | RARUN |
| R/W | R/W | R/W | R/W | R/W | R/W | R/W | R/W | R/W |
| Initial value | 0 | 0 | 0 | 0 | 0 | 0 | 0 | 0 |

RADCON is a special function register (SFR) used to control A/D conversion operation of the RC-ADC.

[Description of Bits]

- **RARUN** (bit 0)

The RARUN bit is used to start or stop A/D conversion of the RC-ADC. When RARUN is set to “1”, A/D conversion starts and when set to “0”, A/D conversion stops. If Counter A or Counter B overflows with RARUN set to “1”, the bit is automatically reset to “0”.

RARUN is set to “0” at system reset.

| RARUN | Description |
|-------|---------------------------------------|
| 0 | Stops A/D conversion (initial value). |
| 1 | Starts A/D conversion. |

21.3 Description of Operation

Counter A (RADCA0 and RADCA1) is a 16-bit binary counter for counting the base clock (BSCLK), which is used as the standard of time. Counter A can count up to 0FFFFH.

Counter B (RADCB0 to RADCB1) is a 16-bit binary counter for counting the oscillator clock (RCCLK) of the RC oscillator circuits. Counter B can count up to 0FFFFH.

Counters A and B are provided with overflow flags (OVFA and OVFB, respectively). Each overflow output results in generation of an RC-ADC interrupt request signal (RADINT). Use the RADI bit of the RC-AC mode register (RADMOD) to select whether to generate an overflow interrupt by an overflow on Counter A or Counter B: setting RADI to “0” specifies Counter A overflow and setting it to “1” specifies Counter B overflow.

The RARUN bit of the RC-AD control register (RADCON) is used to start or stop RC-ADC conversion operation. When RARUN is set to “0”, the oscillator circuits stop, so that counting will not be performed. When RARUN is set to “1”, RC oscillation starts, when the RC oscillator clock (RCCLK) and the base clock (BSCLK) start counting through Counter B and Counter A.

The RC oscillation section has a total of eight types of oscillation modes based on the two oscillator circuits of RCOSC0 and RCOSC1, and mode selection is made by the RC-ADC mode register (RADMOD).

P30–34, P44–47, and P35 must be configured as their secondary function input or output when using 1) the RC oscillator circuit RCOSC0, 2) the RC oscillator circuit RCOSC1, and 3) the RC monitor pin (RCM) that outputs RC oscillation waveforms, respectively. For the RC oscillator circuit configuration, see "21.1.2 Configuration." For the secondary functions of Port 3, see Chapter 16, “Port 3.” For the secondary functions of Port 4, see Chapter 17, “Port 4.”

21.3.1 RC Oscillator Circuits

RC-ADC performs A/D conversion by converting the oscillation frequency ratio between a reference resistor (or capacitor) and a resistive sensor (or capacitive sensor) such as a thermistor to digital data.

By making RC oscillation occur both on the reference side and on the sensor side with the reference capacitor the error factor that the RS oscillator circuit itself is eliminated, thereby making it possible to perform the A/D conversion of the characteristics of the sensor itself.

Also, by calculating the ratio between the oscillation frequency on the reference side and that on the sensor side and then calculating the correlation between the calculated ratio and temperatures that the sensor characteristics have in advance, a temperature can be obtained based on that calculated ratio.

Table 21-1 lists the eight types of oscillation modes, one of which is selected by the RC-ADC mode register (RADMOD) OM3–0 bits.

Table 21-1 Oscillation Modes from Which Selection Is Made by OM3–0 Bits

| Mode No. | RADMOD | | | | RCOSC0 output pin | | | | RCOSC1 output pin | | | Mode | |
|----------|--------|-----|-----|-----|-------------------|-----|------|-----|-------------------|-----|-----|------------------------------------|-------------------------|
| | OM3 | OM2 | OM1 | OM0 | RS0 | RT0 | CRT0 | CS0 | RS1 | RT1 | CS1 | | |
| 0 | 0 | 0 | 0 | 0 | Z | Z | Z | Z | Z | Z | Z | IN0 external clock input mode | |
| 1 | 0 | 0 | 0 | 1 | 1/0 | Z | Z | 0/1 | Z | Z | Z | RS0–CS0 oscillation | RCOSC0 oscillation mode |
| 2 | 0 | 0 | 1 | 0 | Z | 1/0 | Z | 0/1 | Z | Z | Z | RT0–CS0 oscillation | |
| 3 | 0 | 0 | 1 | 1 | Z | Z | 1/0 | 0/1 | Z | Z | Z | RT _{0,1} –CS0 oscillation | |
| 4 | 0 | 1 | 0 | 0 | 1/0 | Z | 0/1 | Z | Z | Z | Z | RS0–CT0 oscillation | |
| 5 | 0 | 1 | 0 | 1 | Z | Z | Z | Z | 1/0 | Z | 0/1 | RS1–CS1 oscillation | RCOSC1 oscillation mode |
| 6 | 0 | 1 | 1 | 0 | Z | Z | Z | Z | Z | 1/0 | 0/1 | RT1–CS1 oscillation | |
| 7 | 0 | 1 | 1 | 1 | Z | Z | Z | Z | Z | Z | Z | IN1 external clock input mode | |
| 8 | 1 | * | * | * | Z | Z | Z | Z | Z | Z | Z | (Prohibited) | |

Note) * : Indicates arbitrary.
 Z : Indicates high-impedance output.
 1/0, 0/1 : Indicates active output.
 (Prohibited) : The oscillator clock is not supplied even by setting the RARUN bit to “1” or by starting A/D conversion.

In Table 21-1, mode No.0 and mode No.7 are modes where external clocks to be input to the IN0 or IN1 pin are used for measurement with the RC oscillator circuit stopped.

As shown in Table 21-1, the two oscillator circuits, RCOSC0 and RCOSC1, are so specified that they cannot operate concurrently in order to prevent interference in oscillation from occurring when they oscillate concurrently.

The relationship between an oscillation frequency f_{RCCLK} and an RC constant is expressed by the following equation:

$$\frac{1}{f_{RCCLK}} = t_{RCCLK} = k_{RCCLK} \cdot R \cdot C$$

where t_{RCCLK} is the period of the oscillator clock, k_{RCCLK} the proportional constant, and $R \times C$ the product of capacitances CS , CT , $(CS+CVR)$ and $(CT+CVR)$ and resistances RS and RT . The value of k_{RCCLK} slightly changes depending on the value of the supply voltage V_{DD} , RI , R , or C .

Table 21-2 lists the typical k_{RCCLK} values.

Table 21-2 Typical Values of the Proportional Constant k_{RCCLK} of RC Oscillator Circuits

| V_{DD} (V) | CS_n, CT_n (pF) | CVR_n (pF) | RS_n, RT_n (k Ω) | k_{RCCLK} (Typ.) |
|--------------|-------------------|--------------|----------------------------|--------------------|
| 3 | 560 | 820 | 10 | 1.26 |
| | 560 | 820 | 100 | 1.24 |
| 3 | 560 | 820 | 15 | 1.25 |
| | 560 | 820 | 105 | 1.24 |
| 1.5 | 560 | 820 | 15 | 1.26 |
| | 560 | 820 | 105 | 1.22 |

Note) $n=0,1$

Note:

Out of the Port 3 and Port 4 pins, pins that are to be used for the RC-ADC function must be configured as secondary function input or output using the mode register (P3MOD0, P4MOD0, P4MOD1) of the corresponding port.

All the Port 3 pins except P35/RCM (see Section 21.1.3, "List of Pins") are configured as pins dedicated to the RC-ADC function during A/D conversion. Therefore, all the Port 3 pins except P35 cannot be used as their primary functions in oscillation mode No. 0, 1, 2, 3 or 4, which is selected by the RADMOD register. In the same way, the P44 to P47 pins of Port 4 cannot be used as their primary functions in oscillation mode No. 5, 6 or 7.

Figures 21-2 to 24-5 show the oscillator circuit configurations, the modes of oscillation for each configuration, and the OM3-0 bit settings.

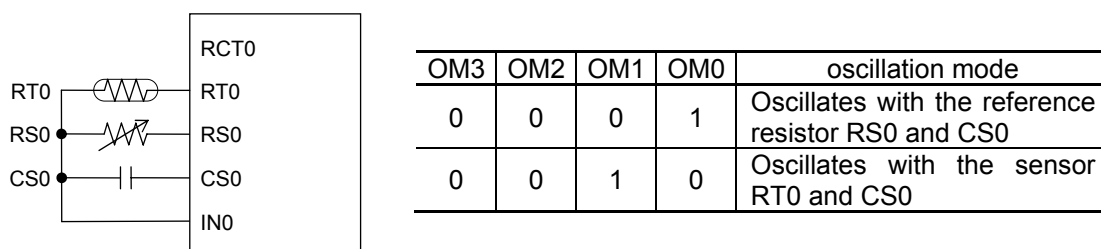
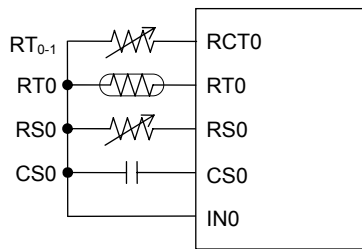

Figure 21-2 When RCOSC0 Is Used for Measurement with One Resistive Sensor

Note:

The unused pin RCT0 shown in Figure 21-2 is configured as a pin dedicated to the RC-ADC function during A/D conversion; therefore, during A/D conversion, RCT0 cannot be used as a primary function port (P34).



| OM3 | OM2 | OM1 | OM0 | oscillation mode |
|-----|-----|-----|-----|--|
| 0 | 0 | 0 | 1 | Oscillates with the reference resistor RS0 and CS0 |
| 0 | 0 | 1 | 0 | Oscillates with the sensor RT0 and CS0 |
| 0 | 0 | 1 | 1 | Oscillates with the reference resistor RT ₀₋₁ and CS0 |

Figure 21-3 When RCOSC0 Is Used for Measurement with One Resistive Sensor
 (Two points are adjusted with two reference resistors)

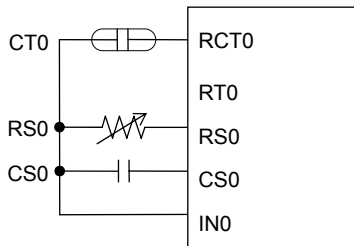

| OM3 | OM2 | OM1 | OM0 | oscillation mode |
|-----|-----|-----|-----|--|
| 0 | 0 | 0 | 1 | Oscillates with the reference resistor RS0 and CS0 |
| 0 | 1 | 0 | 0 | Oscillates with the sensor RS0 and CT0 |

Figure 21-4 When RCOSC0 Is Used for Measurement with One Capacitive Sensor

Note:

The unused pin RT0 shown in Figure 21-4 is configured as a pin dedicated to the RC-ADC function during A/D conversion; therefore, during A/D conversion, RT0 cannot be used as a primary function port (P33).

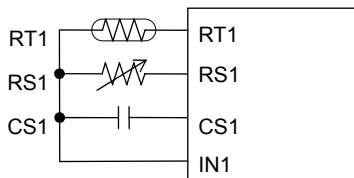

| OM3 | OM2 | OM1 | OM0 | oscillation mode |
|-----|-----|-----|-----|--|
| 0 | 1 | 0 | 1 | Oscillates with the reference resistor RS1 and CS1 |
| 0 | 1 | 1 | 0 | Oscillates with the sensor RT1 and CS1 |

Figure 21-5 When RCOSC1 Is Used for Measurement with One Resistive Sensor

21.3.2 Counter A/Counter B Reference Modes

There are the following two modes of RC-ADC conversion operation:

•Counter A reference mode (RADMOD RADI = “0”)

In this mode, a gate time is determined by Counter A and the base clock (BSCLK), which is used as the time reference, then the RC oscillator clock (RCCLK) is counted by Counter B within the gate time to make the content of Counter B the A/D conversion value.

The A/D conversion value is proportional to RC oscillation frequency.

•Counter B reference mode (RADMOD RADI = “1”)

In this mode, a gate time is determined by Counter B and the RC oscillator clock (RCCLK), and the base clock (BSCLK), which is used as the time reference, is counted by Counter A within the gate time to make the content of Counter A the A/D conversion value.

The /D conversion value is inversely proportional to RC oscillation frequency.

(1) Operation in Counter A reference mode

Figure 21-6 shows the operation timing in Counter A reference mode.

Following is an example of operation procedure in Counter A reference mode:

- ① Preset to Counter A (RADCA1 and RADCA0) the value obtained by subtracting the count value “nA0” from the maximum value + 1 (10000H). The product of the count value “nA0” and the BSCLK clock cycle indicates the gate time.
- ② Preset “0000H” to Counter B (RADCB1 and RADCB0).
- ③ Set the OM3–OM0 bits of RADMOD to desired oscillation mode. (See Table 21-1.)
- ④ Set the RADI bit of RADMOD to “0” to specify generating of an interrupt request signal by Counter A overflow.
- ⑤ Set the RARUN bit of RADCON to “1” to start A/D conversion.

Counter A starts counting of the base clock (BSCLK) when RARUN is set to “1” and the RCON signal (signal synchronized with the fall of the base clock) is set to “1”. When Counter A overflows, the RARUN bit is automatically reset to “0” (Ⓒ) and counting is terminated. At the same time, an RC-ADC interrupt request (RADIN) occurs (Ⓓ).

When the RCON signal is set to “1”, the RC oscillator circuit starts operation and Counter B starts counting of the RC oscillator clock (RCCLK). When the RARUN bit is reset to “0” due to overflow of Counter A, RC oscillation stops and Counter B stops counting.

The final count value “nB0” of Counter B is the RCCLK count value during the gate time “nA0 × t_{BSCLK}” and is expressed by the following expression:

$$nB0 \cong nA0 \cdot \frac{t_{BSCLK}}{t_{RCCLK}} \propto f_{RCCLK}$$

where t_{BSCLK} indicates the BSCLK period and t_{RCCLK} the RCCLK period. That is, “nB0” is a value proportional to the RC oscillation frequency f_{RCCLK}.

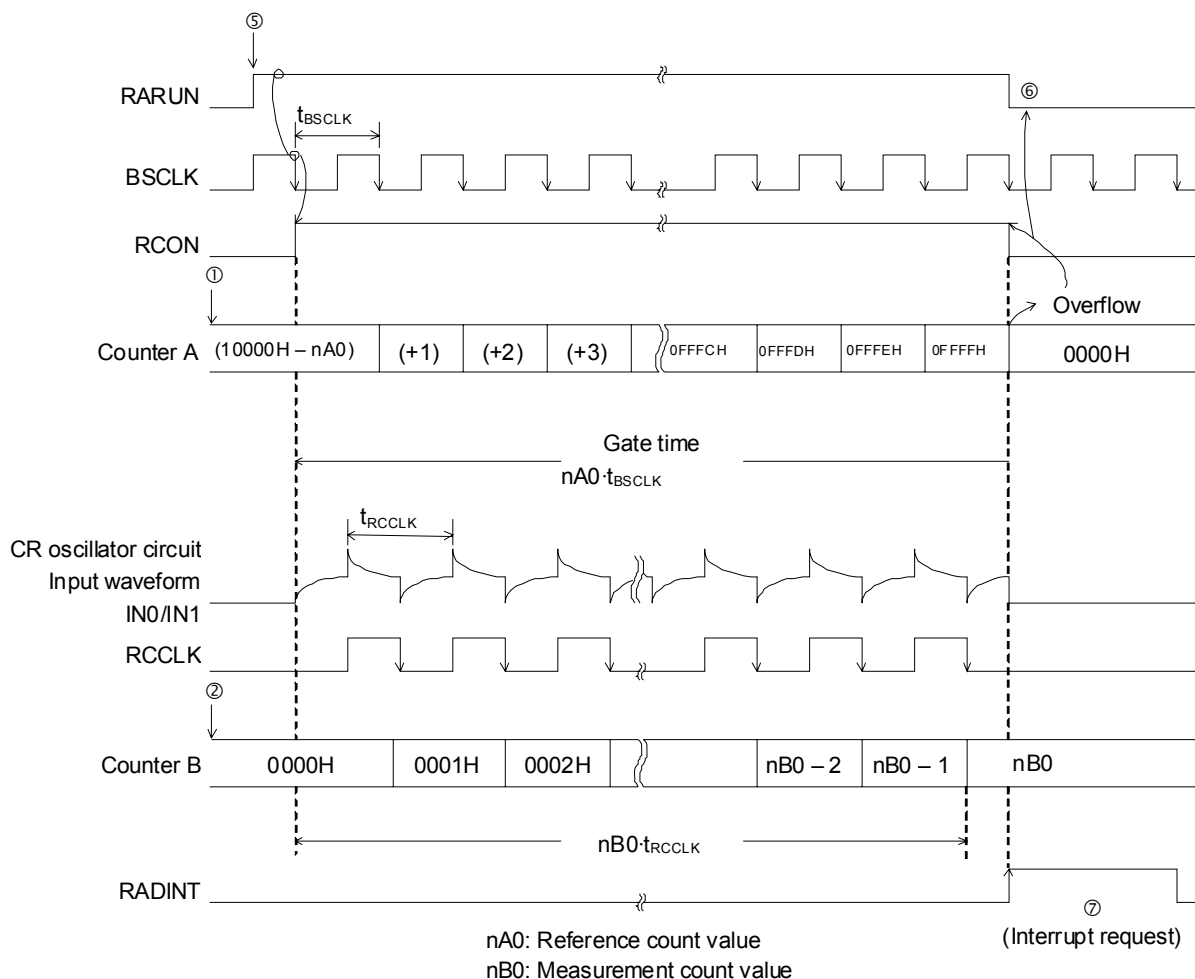

Figure 21-6 Operation Timing in Counter A Reference Mode

(2) Operation in Counter B reference mode

Figure 21-7 shows the operation timing in Counter B reference mode.

Following is an example of operation procedure in Counter B reference mode:

- ① Preset to Counter B (RADCB1 and RADCB0) the value obtained by subtracting the count value “nB1” from the maximum value + 1 (10000H). The product of the count value “nB1” and the RCCLK clock cycle indicates the gate time.
- ② Preset “0000H” to Counter A (RADCA1 and RADCA0).
- ③ Set the OM3–OM0 bits of RADMOD to desired oscillation mode. (See Table 21-1.)
- ④ Set the RADI bit of RADMOD to “1” to specify generating of an interrupt request signal by Counter B overflow.
- ⑤ Set the RARUN bit of RADCON to “1” to start A/D conversion.

When the RARUN bit is set to “1” and the RCON signal (signal synchronized with the fall of the base clock) is set to “1”, the RC oscillator circuit starts operation and Counter B starts counting of the RC oscillator clock (RCCLK). When Counter B overflows, the RARUN bit is automatically reset (⑥) and conversion operation terminates. At the same time, an RC-ADC interrupt request (RADINT) occurs. (⑦)

When the RCON signal is set to “1”, Counter A starts counting of the base clock (BSCLK). When the RARUN bit is reset due to overflow of Counter B, Counter A stops counting.

The final count “nA1” of Counter A is the CLK count value during the gate time “nB1 x t_{RCCLK}” and is expressed by the following expression:

$$nA1 \cong nB1 \cdot \frac{t_{RCCLK}}{t_{BSCLK}} \propto \frac{1}{f_{RCCLK}}$$

That is, “nA1” is a value inversely proportional to the RC oscillation frequency f_{RCCLK} .

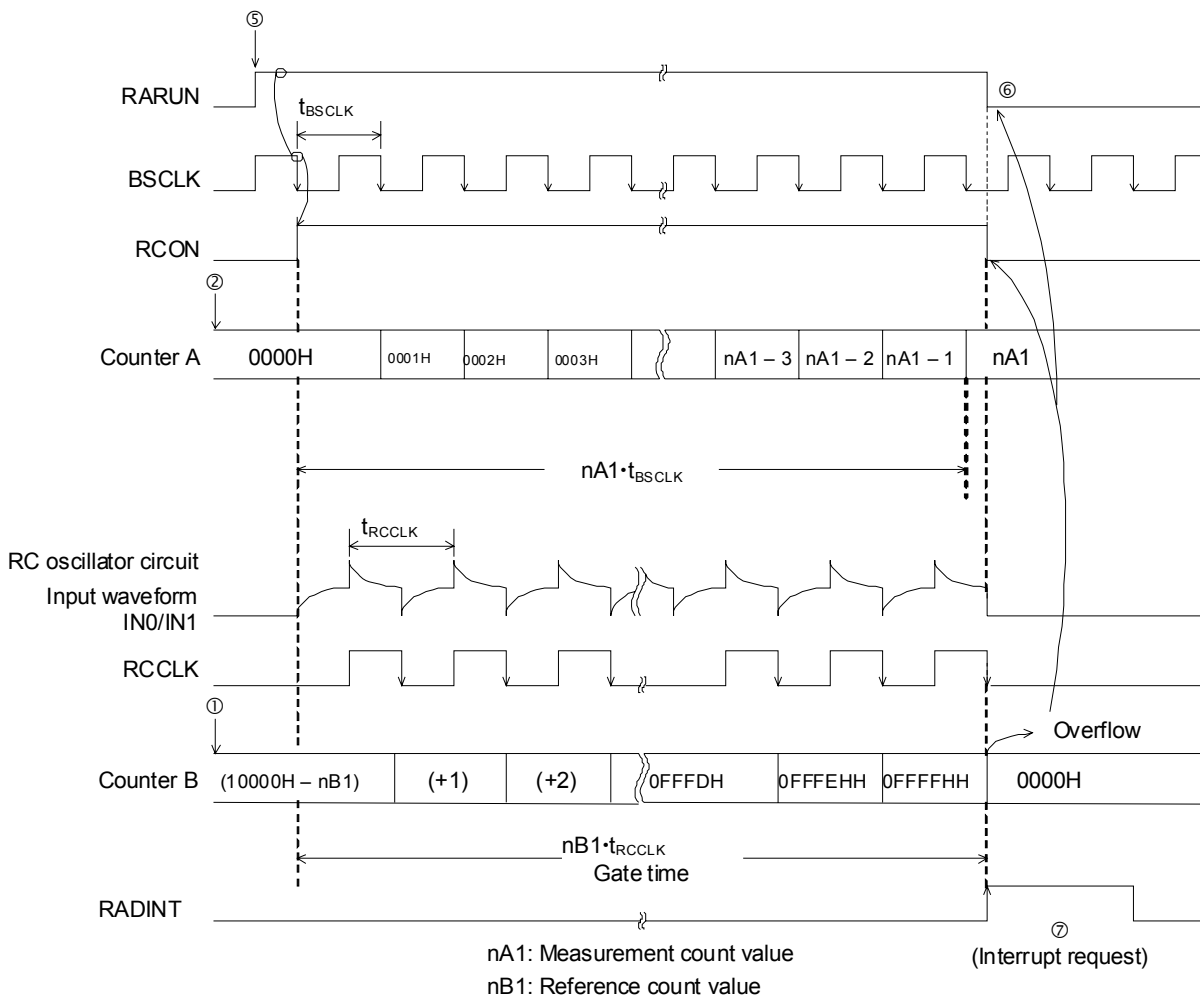

Figure 21-7 Operation Timing in Counter B Reference Mode

21.3.3 Example of Use of RC Oscillation Type A/D Converter

This section describes the method of performing A/D conversion for sensor values in Counter A and B reference modes by taking temperature measurement by a thermistor as an example.

Figure 21-8 shows the circuit configuration of 1-thermistor RC oscillator circuit using RCOSC0.

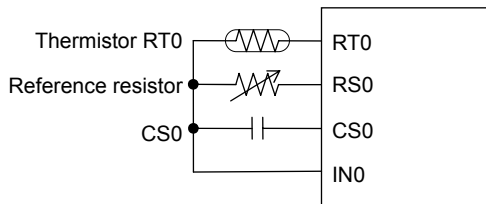

Figure 21-8 Configuration of 1-Thermistor RC Oscillator Circuit Using RCOSC0

Figure 21-9 shows the temperature characteristics of the thermistor resistance RT0.

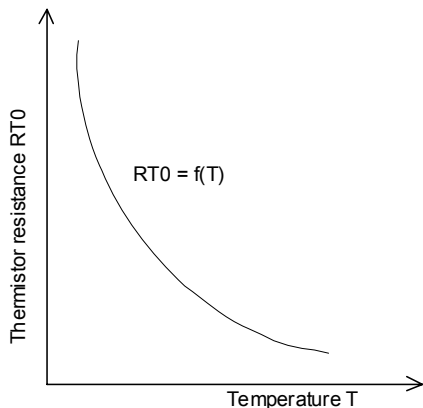

Figure 21-9 Temperature Characteristics of Thermistor Characteristics

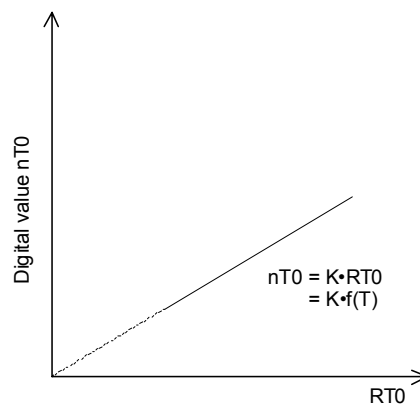

Figure 21-10 A/D Conversion (Ideal characteristics when nT0 is proportional to RT0)

RT0 is expressed as a function of temperature T by the following equation:

$$RT0 = f(T)$$

Figure 21-10 shows the ideal characteristics of A/D conversion with the assumption that RT0 is an analog quantity. In the ideal characteristics, the A/D conversion value nT0 will purely depend on RT0 only. Assuming that nT0 is proportional to RT0, let proportional constant be K, then nT0 has the following relationship with temperature T:

$$nT0 = K \cdot RT0 = K \cdot f(T) \quad \dots \text{Expression A}$$

Therefore, temperature T can be expressed as a digital value by performing the conversion processing that accords with the characteristics shown in Figure 21-9 for nT0 by software.

To convert from an RT0 value to a digital value, the ratio is used between a) the oscillation frequency by the thermistor connected to the RT0 pin and the capacitor connected to the CS0 pin and b) the oscillation frequency by the reference resistor (which ideally should have no temperature characteristics) connected to the RS0 pin and the capacitor connected to the CS0 pin. This is for making the conditions other than resistance equal to eliminate the error factor in oscillation characteristics.

As shown in Figures 21-9 and 21-11, the RT0 value depends on temperature T and the RS0 value is assumed to be constant regardless of temperature T. It is ideal if the characteristics of the oscillation frequency f_{OSC} to temperature T using these resistances will be like the solid lines in Figures 21-12 and 21-13; however, in reality, it would appear that they will be like the dotted lines due to error factors such as IC temperature characteristics.

Since the condition of f_{RCCLK} (RT0) and that of f_{RCCLK} (RS0) are the same except for the resistances, the error ratios are almost the same; therefore, errors can almost be eliminated by using the ratio between f_{RCCLK} (RT0) and f_{RCCLK} (RS0).

The ratio between $f_{RCCLK}(RT0)$ and $f_{RCCLK}(RS0)$ is equivalent to the above-mentioned A/D conversion value $nT0$ that should ideally depend only on $RT0$.

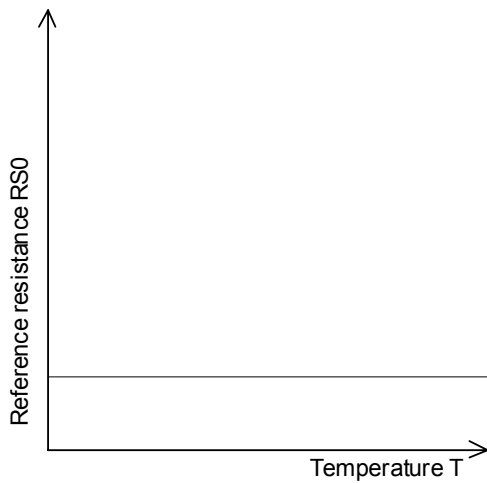

Figure 21-11 Temperature Characteristics of Reference Resistor

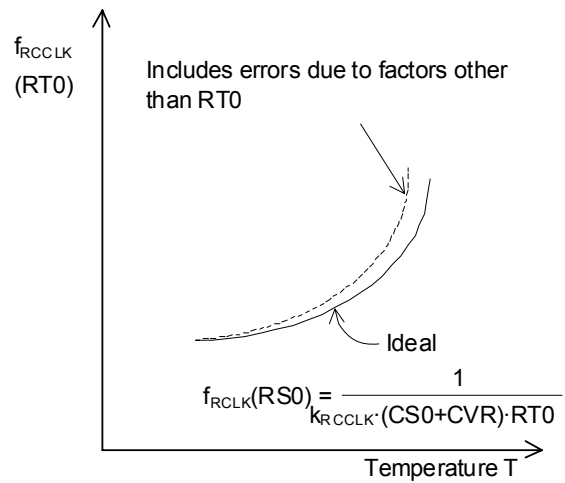

Figure 21-12 Oscillation Characteristics of Thermistor

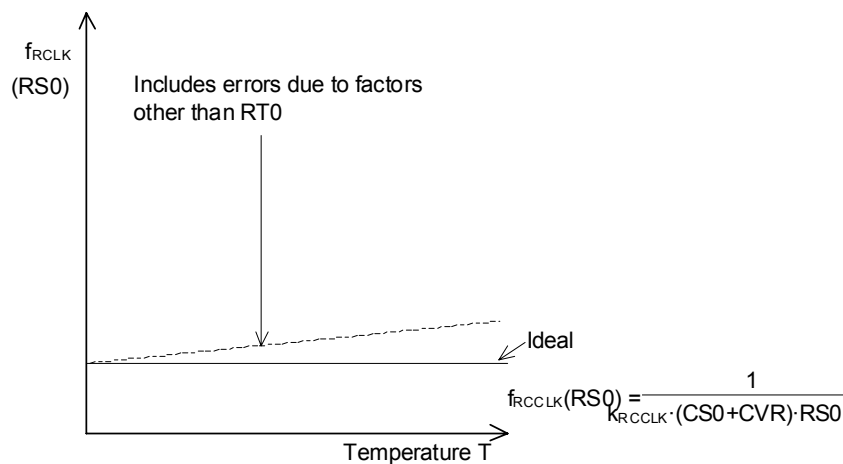

Figure 21-13 Oscillation Characteristics of Reference Resistor

Figure 21-14 shows, as an example of method, a timing chart of one cycle of conversion from analog value $RT0$ to a digital value, that is, A/D conversion.

Basically, one A/D conversion cycle must consist of two steps, as shown in Figure 21-14. The reason for requiring two steps is that the reference resistor and the thermistor must first be oscillated separately and then the ratio between the oscillation frequencies of them is used, as described above.

In the example below, operation for these two steps is performed using the following combination:

- First step = RC oscillation with $RS0$ in Counter A reference mode
- Second step = RC oscillation with $RT0$ in Counter B reference mode

Besides this, there would be several possible A/D conversion methods.

In the above method, the operation time (gate time) for the second step fluctuates depending on the value of thermistor $RT0$. To avoid the fluctuation of the operation time, using a method that uses the following combination is recommended:

- First step = RC oscillation with $RS0$ in Counter B reference mode
- Second step = RC oscillation with $RT0$ in Counter A reference mode

A/D conversion procedure is explained below by taking Figure 21-14 as an example.

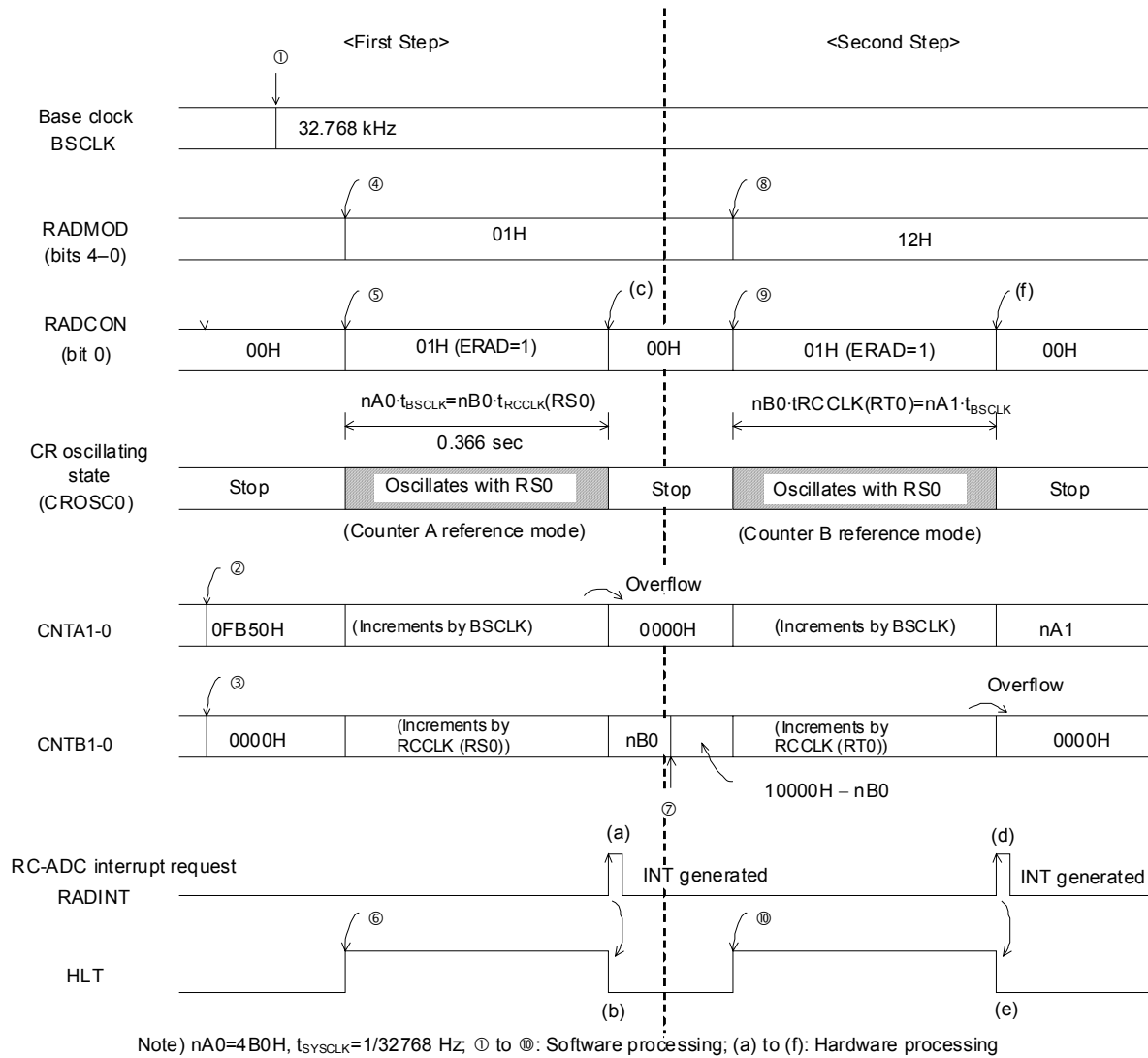

Figure 21-14 Timing Chart for 1 Cycle of A/D Conversion (Example)

<First step>

- ① Set the base clock to 32.768 kHz. (Write “00H” in FCON0.)
- ② Preset “10000H – nA0” in Counter A.
- ③ Preset “0000H” in Counter B.
- ④ Write “01H” in RADMOD to select Counter A reference mode and the oscillation mode that uses reference resistance RS0.
- ⑤ Write “01H” in RADCON to start A/D conversion operation.
- ⑥ Write “1” in the HLT bit of SBYCON to set the device to HALT mode.

Note:

In this example, nA0 is set to 4B0H because the gate time “nA0 x tBSCLK” in oscillation mode with reference resistor RS0 is set to 0.366 second. The value of nA0 is related to how much the margin of the quantization error of the A/D conversion is: the greater the nA0 value is, the smaller the margin of error becomes.
 To reduce noise contamination to the RC oscillator circuit caused by CPU operation, it is recommended to constantly put the device into HALT mode during operation of RC oscillation.

From this point of time, the RC oscillator circuit (RCOSC0) continues oscillation for about 0.366 second with the reference resistance RS0. Then, when Counter A overflows, the RADINT signal is set to “1” and an RC-ADC interrupt

request is generated. (Section (a)). Also, the generation of interrupt request releases HALT mode (section (b)) and at the same time, A/D conversion operation stops. (Section (c), RARUN bit = "0"). At this time, Counter A is set to "0000H". The content of Counter B at this time is expressed by the following expression:

$$nB0 = nA0 \cdot \frac{t_{BSCLK}}{t_{RCCLK}(RS0)} \quad \dots \text{Expression B}$$

That completes the operations in First Step.

<Second step>

- ① Calculate "10000H – nB0" from the content of Counter B "nB0" and set the obtained value in Counter B. At this point, Counter A needs to be cleared; however, no processing is required since the counter is already set to "0000H".
- ② Write "12H" in RADMOD to select Counter B reference mode and the oscillation mode that uses thermistor RT0.
- ③ Write "01H" in RADCON to start A/D conversion operation.
- ④ Write "1" in the HLT bit of SBYCON to set the device to HALT mode.

The RC oscillator circuit (RCOSC0) oscillates with thermistor RT0 from this point until Counter B overflows. This period is equal to the product of "nB0" obtained in the First Step and the oscillation period $t_{RCCLK}(RT0)$ using RT0. When Counter B overflows, the RADINT signal is set to "1" and an RC-ADC interrupt request is generated. (Section (d)). Also, the generation of interrupt request releases HALT mode (section (e)) and at the same time, A/D conversion operation stops. (Section (f), RARUN bit = "0"). This completes the operations in Second Step.

The content of Counter A at this time becomes the A/D conversion value nA1, which is expressed by the following expression:

$$nA1 = nB0 \cdot \frac{t_{RCCLK}(RT0)}{t_{BSCLK}} \quad \dots \text{Expression C}$$

From expressions B and C, nA1 is expressed by the following expression:

$$nA1 = nA0 \cdot \frac{t_{RCCLK}(RT0)}{t_{RCCLK}(RS0)} \quad \dots \text{Expression D}$$

where $t_{RCCLK}(RS0)$ is the oscillator clock period by reference resistor RS0 and $t_{RCCLK}(RT0)$ the oscillator clock period by thermistor RT0.

Since the oscillation period is expressed by " $t_{RCCLK} = k_{RCCLK} \times R \times C$ ", $t_{RCCLK}(RS0)$ and $t_{RCCLK}(RT0)$ are expressed by the following expressions:

$$t_{RCCLK}(RS0) = k_{RCCLK} \cdot (CS0 + CVR) \cdot RS0 \quad \dots \text{Expression E}$$

$$t_{RCCLK}(RT0) = k_{RCCLK} \cdot (CS0 + CVR) \cdot RT0$$

When expression E is substituted for expression D, nA1 will be:

$$nA1 = nA0 \cdot \frac{RT0}{RS0}$$

Since "nA0" ("4B0H" in this example) and RS0 are constants whose values are fixed, "nA1" is a digital value proportional to RT0. This very "nA1" corresponds to "nT0" in expression A.

That concludes the description of the A/D conversion method using a thermistor. "nA1" that has been obtained must further be converted to a value such as a temperature indication value for thermometer by program according to the temperature-to-resistance characteristics of the thermistor.

21.3.4 Monitoring RC Oscillation

The RC oscillator clock (RCCLK) can be output using the secondary function of the P35 pin of Port 3. See Chapter 20, "Port 3," for the details of the secondary function of P35.

Monitoring RC oscillation is useful for checking the characteristics of the RC oscillator circuit. That is, the relationship between a sensor, such as a thermistor, and the oscillation frequency can be measured. For instance, the coefficient for conversion from the above-described nA1 value to a temperature indication value can be obtained by checking the relationship between the ambient temperature of a thermistor-incorporated RC oscillator circuit, the oscillation frequency with thermistor RT0, and the oscillation frequency with reference resistor RS0.

Note:

P35 (RCM) is a monitor pin for oscillation clock. The Channel 0 and Channel 1 share the monitor pin.

Please use P35 (RCM) for the evaluation purpose and disable the output while operating in an actual application to minimize the noise.

21.4 Specifying Port Registers

To enable the RC-ADC function, the applicable bit of each related port register needs to be set. See Chapter 16, “Port 3” and Chapter 18, “Port 4” for detail about the port registers.

21.4.1 Functioning P35(RCM), P34(RCT0), P33(RT0), P32(RS0), P31(CS0) and P30(IN0) as the RC-ADC(Ch0)

Set P35MD0-P30MD0(bit5-bit0 of P3MOD0 register) to “1”, for specifying the RC-ADC as the secondary function of P35, P34, P33, P32, P31 and P30.

| Register name | P3MOD0 register (Address: 0F21CH) | | | | | | | |
|---------------|-----------------------------------|--------|---------------|---------------|---------------|---------------|---------------|---------------|
| Bit | 7 | 6 | 5 | 4 | 3 | 2 | 1 | 0 |
| Bit name | P37MD0 | P36MD0 | P35MD0 | P34MD0 | P33MD0 | P32MD0 | P31MD0 | P30MD0 |
| Setting value | - | - | 1 | 1 | 1 | 1 | 1 | 1 |

Set the P34C1 to P30C1 bits (P3CON1 register bits 4 to 0) to “0”, the P34C0 to P30C0 bits (P3CON0 register bits 4 to 0) to “0”, and the P34DIR to P30DIR bits (P3DIR register bits 4 to 0) to “1” for selecting the state mode of the P34, P33, P32, P31, and P30 to high-impedance input. The P34C1-P30C1 bit and P34C0-P30C0 bit can be set to all “1” instead of all “0” to select the high-impedance inputs.

Set the P35C1 bit (P3CON1 register bit 5) to “1”, the P35C0 bit (P3CON0 register bit 5) to “1”, and the P35DIR bit (P3DIR register bit 5) to “0” for selecting the P35 state mode to CMOS output.

| Register name | P3CON1 register (Address: 0F21BH) | | | | | | | |
|---------------|-----------------------------------|-------|--------------|--------------|--------------|--------------|--------------|--------------|
| Bit | 7 | 6 | 5 | 4 | 3 | 2 | 1 | 0 |
| Bit name | P37C1 | P36C1 | P35C1 | P34C1 | P33C1 | P32C1 | P31C1 | P30C1 |
| Setting value | - | - | 1 | 0 | 0 | 0 | 0 | 0 |

| Register name | P3CON0 register (Address: 0F21AH) | | | | | | | |
|---------------|-----------------------------------|-------|--------------|--------------|--------------|--------------|--------------|--------------|
| Bit | 7 | 6 | 5 | 4 | 3 | 2 | 1 | 0 |
| Bit name | P37C0 | P36C0 | P35C0 | P34C0 | P33C0 | P32C0 | P31C0 | P30C0 |
| Setting value | - | - | 1 | 0 | 0 | 0 | 0 | 0 |

| Register name | P3DIR register (Address: 0F219H) | | | | | | | |
|---------------|----------------------------------|--------|---------------|---------------|---------------|---------------|---------------|---------------|
| Bit | 7 | 6 | 5 | 4 | 3 | 2 | 1 | 0 |
| Bit name | P37DIR | P36DIR | P35DIR | P34DIR | P33DIR | P32DIR | P31DIR | P30DIR |
| Setting value | - | - | 0 | 1 | 1 | 1 | 1 | 1 |

Data of P35D-P30D bits (bit5-0 of P3D register) do not affect to the RC-ADC function, so don't care the data for the function.

| Register name | P3D register (Address: 0F218H) | | | | | | | |
|---------------|--------------------------------|------|-------------|-------------|-------------|-------------|-------------|-------------|
| Bit | 7 | 6 | 5 | 4 | 3 | 2 | 1 | 0 |
| Bit name | P37D | P36D | P35D | P34D | P33D | P32D | P31D | P30D |
| Setting value | - | - | ** | ** | ** | ** | ** | ** |

- : Bit that does not exist

* : Bit not related to the RC-ADC function

** : Don't care

21.4.2 Functioning P47(RT1), P46(RS1), P45(CS1) and P44(IN1) as the RC-ADC(Ch1)

Set P47MD1-P44MD1 bits(bit7-bit4 of P4MOD1 register) to "0" and set P47MD0-P44MD0(bit7-bit4 of P4MOD0 register) to "1", for specifying the RC-ADC as the secondary function of P47, P46, P45 and P44.

| Register name | P4MOD1 register (Address: 0F225H) | | | | | | | |
|---------------|-----------------------------------|---------------|---------------|---------------|--------|--------|--------|--------|
| Bit | 7 | 6 | 5 | 4 | 3 | 2 | 1 | 0 |
| Bit name | P47MD1 | P46MD1 | P45MD1 | P44MD1 | P43MD1 | P42MD1 | P41MD1 | P40MD1 |
| Setting value | 0 | 0 | 0 | 0 | * | * | * | * |

| Register name | P4MOD0 register (Address: 0F224H) | | | | | | | |
|---------------|-----------------------------------|---------------|---------------|---------------|--------|--------|--------|--------|
| Bit | 7 | 6 | 5 | 4 | 3 | 2 | 1 | 0 |
| Bit name | P47MD0 | P46MD0 | P45MD0 | P44MD0 | P43MD0 | P42MD0 | P41MD0 | P40MD0 |
| Setting value | 1 | 1 | 1 | 1 | * | * | * | * |

Set the P47C1 to P44C1 bits (P4CON1 register bits 7 to 4) to "0", the P47C0 to P44C0 bits (P4CON0 register bits 7 to 4) to "0", and the P47DIR to P44DIR bits (P4DIR register bits 7 to 4) to "1" for selecting the state mode of the P47, P46, P45, and P44 to high-impedance input. The P47C1-P44C1 bit and P47C0-P44C0 bit can be set to all "1" instead of all "0" to select the high-impedance inputs.

| Register name | P4CON1 register (Address: 0F223H) | | | | | | | |
|---------------|-----------------------------------|--------------|--------------|--------------|-------|-------|-------|-------|
| Bit | 7 | 6 | 5 | 4 | 3 | 2 | 1 | 0 |
| Bit name | P47C1 | P46C1 | P45C1 | P44C1 | P43C1 | P42C1 | P41C1 | P40C1 |
| Setting value | 0 | 0 | 0 | 0 | * | * | * | * |

| Register name | P4CON0 register (Address: 0F222H) | | | | | | | |
|---------------|-----------------------------------|--------------|--------------|--------------|-------|-------|-------|-------|
| Bit | 7 | 6 | 5 | 4 | 3 | 2 | 1 | 0 |
| Bit name | P47C0 | P46C0 | P45C0 | P44C0 | P43C0 | P42C0 | P41C0 | P40C0 |
| Setting value | 0 | 0 | 0 | 0 | * | * | * | * |

| Register name | P4DIR register (Address: 0F221H) | | | | | | | |
|---------------|----------------------------------|---------------|---------------|---------------|--------|--------|--------|--------|
| Bit | 7 | 6 | 5 | 4 | 3 | 2 | 1 | 0 |
| Bit name | P47DIR | P46DIR | P45DIR | P44DIR | P43DIR | P42DIR | P41DIR | P40DIR |
| Setting value | 1 | 1 | 1 | 1 | * | * | * | * |

Data of P47D-P44D bits (bit7-4 of P4D register) do not affect to the RC-ADC function, so don't care the data for the function.

| Register name | P4D register (Address: 0F220H) | | | | | | | |
|---------------|--------------------------------|------|------|------|------|------|------|------|
| Bit | 7 | 6 | 5 | 4 | 3 | 2 | 1 | 0 |
| Bit name | P47D | P46D | P45D | P44D | P43D | P42D | P41D | P40D |
| Setting value | ** | ** | ** | ** | * | * | * | * |

* : Bit not related to the RC-ADC function

** : Don't care

Note:

Status of output pins P31-P34 and P45-P47 changes according to the RC oscillation mode specified by OM0-OM3 bit of RADMOD register.

LCD Drivers

22. LCD Driver

22.1 Overview

This LSI includes LCD drivers that display the contents that are set in the display register.

For the ML610407/408/409, the numbers of commons and segments and the maximum number of dots are as shown in Table 22-1.

Table 22-1 Numbers of Commons/Segments and Maximum Number of Dots for ML610407/8/9

| Product name (ML610...) | 407 | 408 | 409 |
|---|------------|------------|------------|
| Number of commons/segments (changeable by software) | 2com-32seg | 2com-36seg | 2com-40seg |
| | 3com-31seg | 3com-35seg | 3com-39seg |
| | 4com-30seg | 4com-34seg | 4com-38seg |
| | 5com-29seg | 5com-33seg | 5com-37seg |
| Maximum number of dots | 145 | 165 | 185 |

The LCD display function consists of four blocks as shown in Figure 22-1:

1. Display registers
2. Display allocation
3. Display control
4. Driver

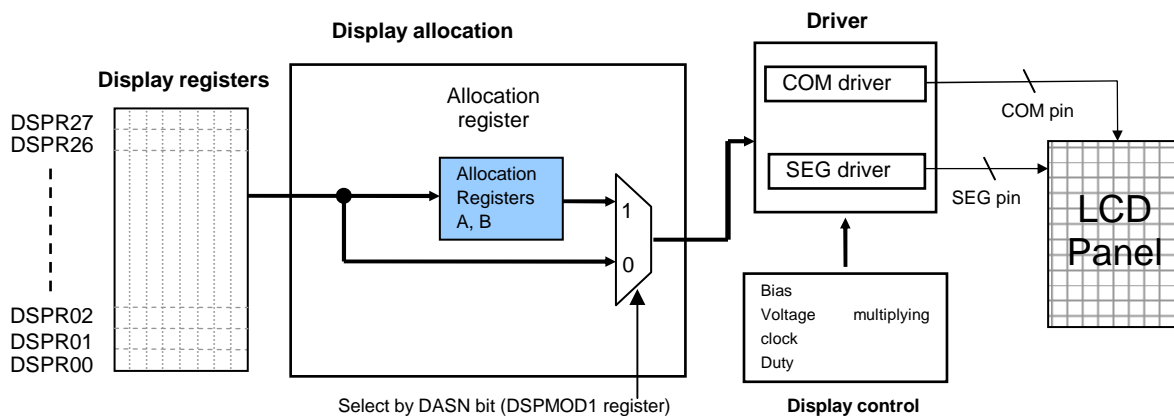

Figure 22-1 Configuration of LCD Display Function

The display registers are used to store the contents to be displayed as bit patterns.

The bit pattern storage method depends on the specification of the LCD panel to be used (display pattern and assignment of the COM pin and SEG pin) and the setting of the display allocation circuit.

The display allocation block controls mapping of the display register for the LCD common/segment.

Using the display allocation registers A and B or not using them is selectable. When using them (Set DASN bit of DSPMOD1 register to "1"), the segment mapping of the display register can be specified in bit units by programming according to the contents of display allocation registers A and B. Therefore, the display register array can be changed in flexible and simplify the software process for display (This function is defined as the programmable display allocation function in the User's Manual). Also, the data specified to the registers A and B can be easily prepared by using LAPIS Semiconductor LCD allocation Tool.

When the display allocation registers A and B are not used (set the DSPMOD1 register's DASN bit to "0"), the display content is controlled only with the display registers.

The display control circuit generates LCD drive waveforms according to the characteristics of the LCD.

A bias, a bias voltage multiplying clock, a duty, and a frame frequency suitable for the LCD panel can be selected.

A) When not using Programmable display allocation function (DASN bit of DSPMOD1 register is "0")
 Suitable for the dot matrix type LCD panel whose common/segment array is approximated to the bit array of the display register.

Figure 22-2 shows an example of the correlation between the display registers and the dot matrix type LCD image.

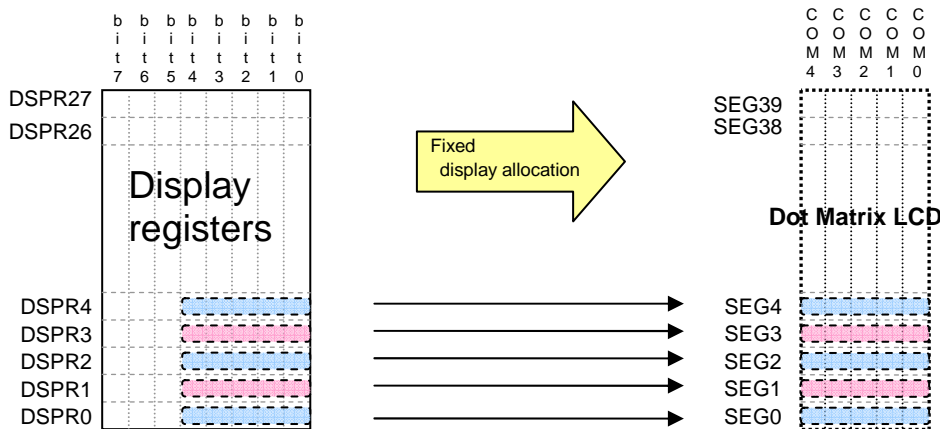

Figure 22-2 Example of Correlation between Display Registers and Dot Matrix Type LCD Image

B) When using Programmable display allocation function (DASN bit of DSPMOD1 register is "1")
 The programmable display allocation function is suitable for the LCD panel of segment type or character type whose common/segment array is restricted by the design or wiring. The display allocation registers A and B can be used to programmatically specify the display register bit-by-bit. This allows the display registers to be arrayed flexibly and thus makes the display processing in the software easier. The content of the display allocation register A (DSmCn) specifies the addresses of the display registers (DSPR00 to 27) to be output to the common "n" of the segment "m." The content of the display allocation register B (DSmCnB) specifies the bits of the display registers (DSPR00 to 27) to be output to the common "n" of the segment "m."

Figure 22-3 shows an example of the correlation between the display registers and the dot matrix type LCD image when the programmable display allocation is used.

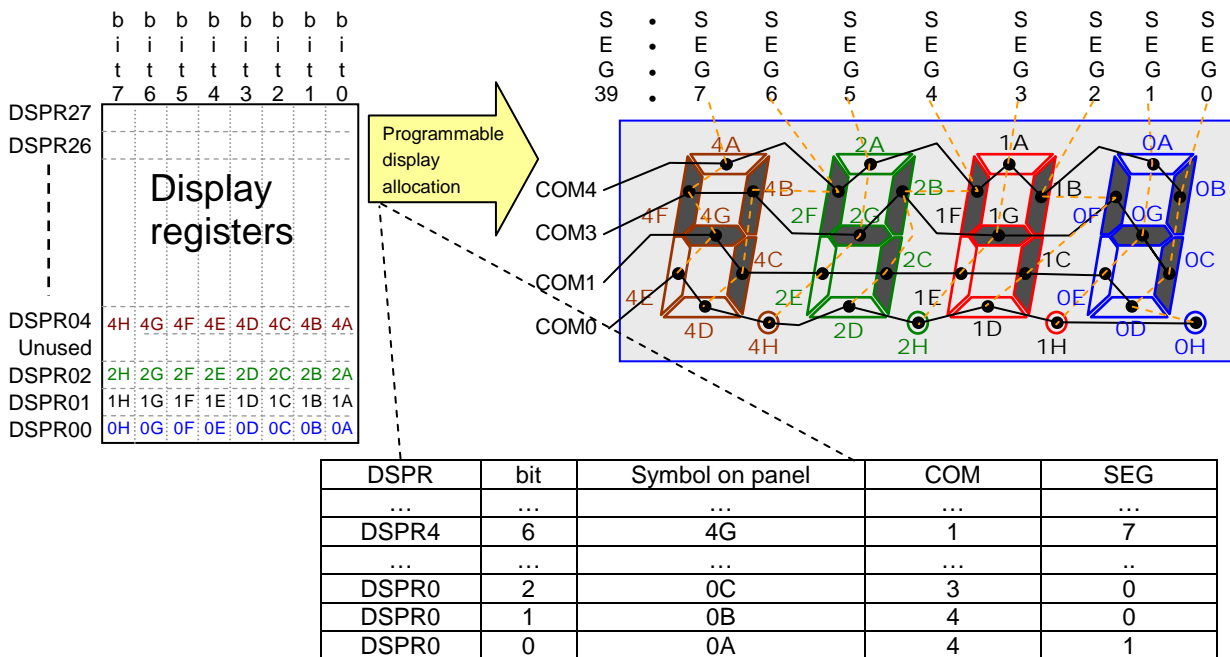

Figure 22-3 An example of correlation between display registers and segment type LCD

22.1.1 Features

The LCD drivers are applicable to various types of LCD panels.

- ML610409: 185 dots max. (37 segments x 5 commons)
- ML610408: 165 dots max. (33 segments x 5 commons)
- ML610407: 145 dots max. (29 segments x 5 commons)
- 1/1 to 1/5 duty
- 1/2 or 1/3 bias (built-in bias generation circuit)
- Frame frequency selectable (4 types)
- Bias voltage multiplying clock selectable (8 types)
- Programmable display allocation function

The programmable display allocation function facilitates software display processing. By using “ALL LCDs on mode” and “ALL LCDs off mode”, LCD panel inspection processing software can be easily created.

22.1.2 Configuration of the LCD Drivers

Figure 22-4 shows the configuration of the LCD drivers and the bias generation circuit.

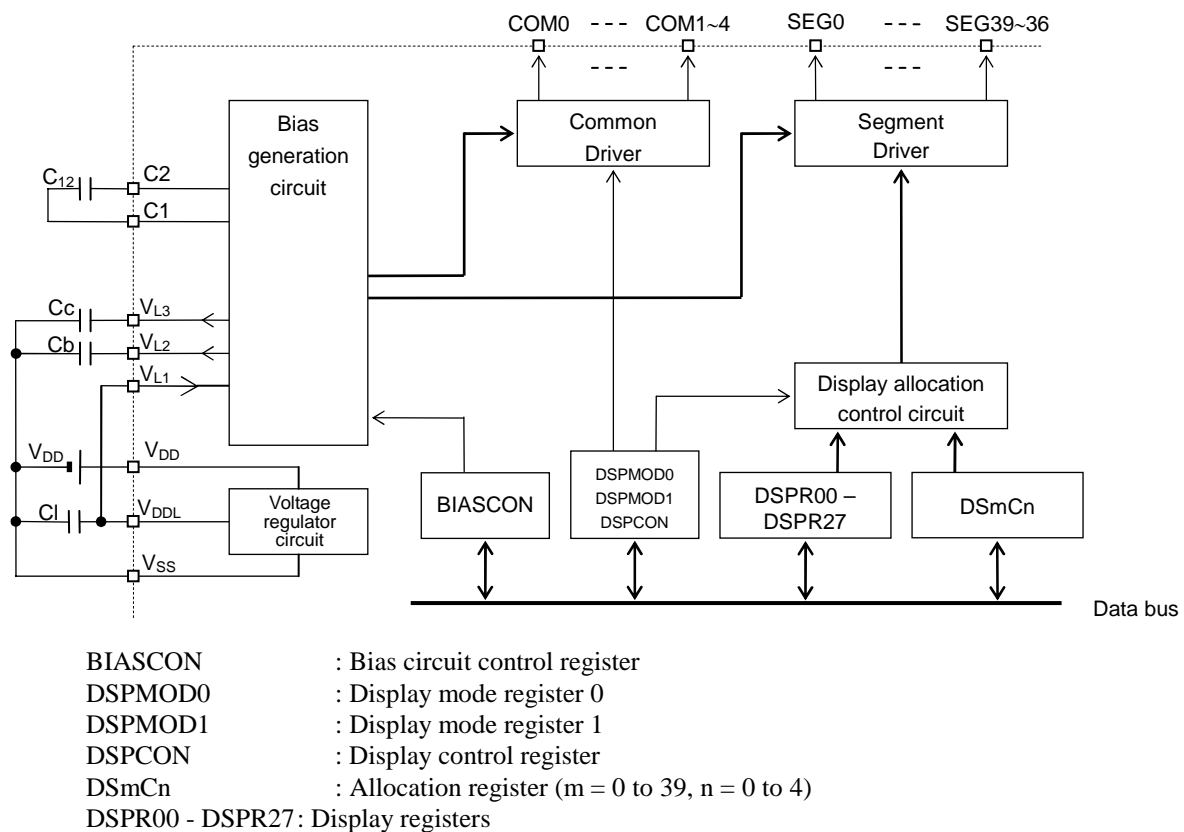

Figure 22-4 Configuration of LCD Drivers and Bias Generation Circuit

22.1.3 Configuration of the Bias Generation Circuit

The bias generation circuit generates LCD drive voltages (V_{L1} to V_{L3}) by multiplying the power supply voltage (V_{DD}) or the voltage (V_{DDL}) generated by the voltage regulator circuit with the capacitor (C_{12}).

When a system reset starts the bias generation circuit operation stops.

Figure 22-5-1 and 22-5-2 show the configuration of the bias generation circuit.

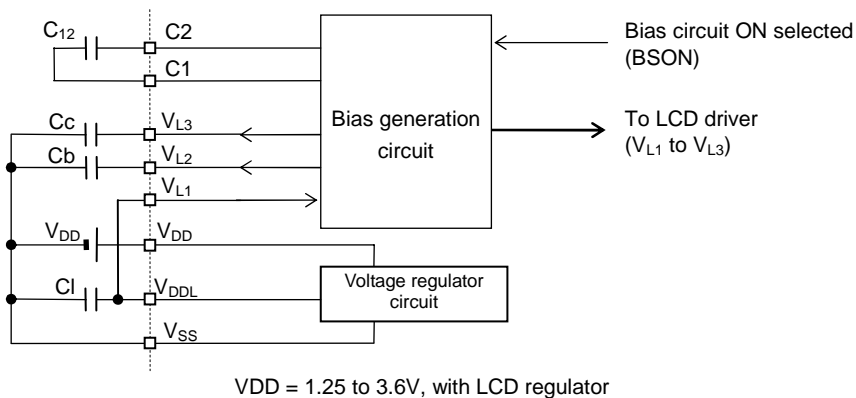
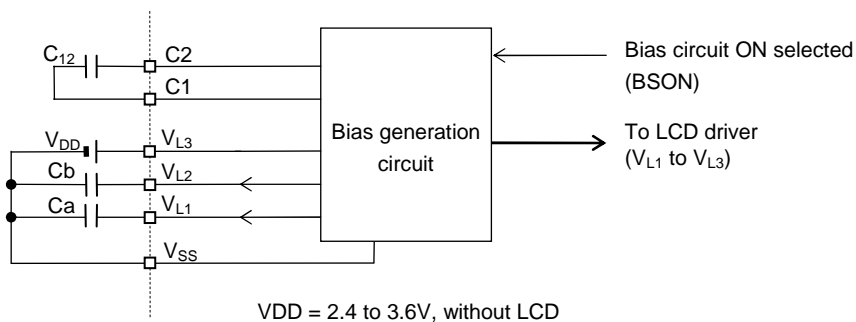
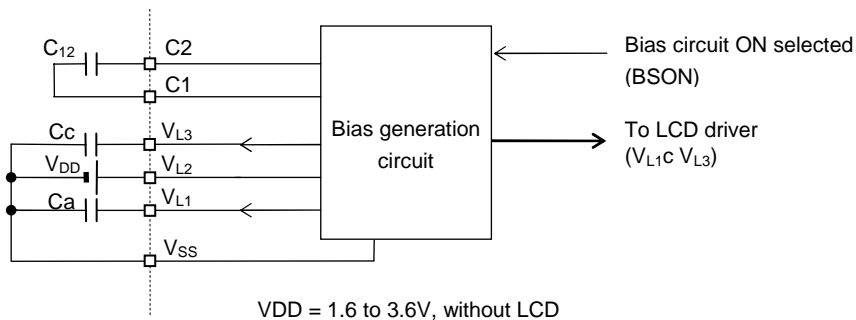

Figure 22-5-1 Configuration of Bias Generation Circuit (1/3 Bias)

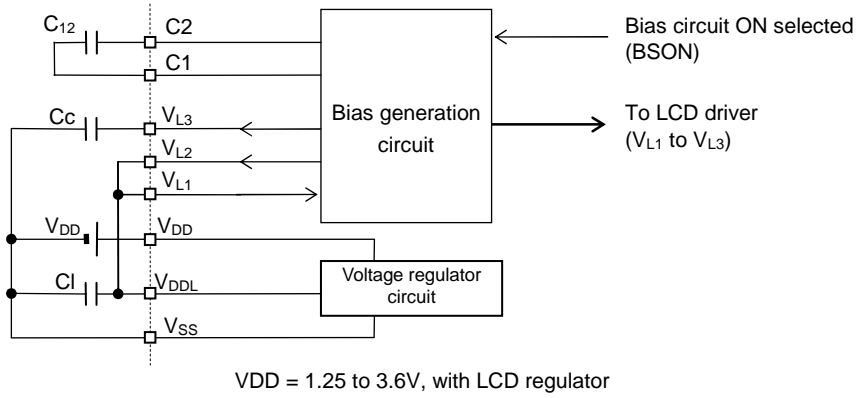
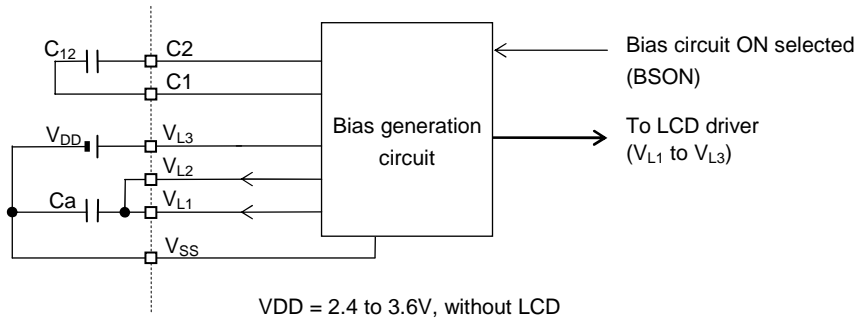

Figure 22-5-2 Configuration of Bias Generation Circuit (1/2 Bias)

22.1.4 List of Pins

| Pin name | Input/output | Function | ML610407 | ML610408 | ML610409 |
|-----------------|--------------|--|----------|----------|----------|
| V _{L1} | — | Power supply pin for LCD bias (internally generated) | ● | ● | ● |
| V _{L2} | — | Power supply pin for LCD bias (internally generated) | ● | ● | ● |
| V _{L3} | — | Power supply pin for LCD bias (internally generated) | ● | ● | ● |
| C1 | — | Capacitor connection pin for LCD bias generation | ● | ● | ● |
| C2 | — | Capacitor connection pin for LCD bias generation | ● | ● | ● |
| COM0 | O | LCD common pin | ● | ● | ● |
| COM1 | O | LCD common pin | ● | ● | ● |
| COM2/SEG0 | O | LCD common/segment pin | ● | ● | ● |
| COM3/SEG1 | O | LCD common/segment pin | ● | ● | ● |
| COM4/SEG2 | O | LCD common/segment pin | ● | ● | ● |
| SEG3 | O | LCD segment pin | ● | ● | ● |
| SEG4 | O | LCD segment pin | ● | ● | ● |
| SEG5 | O | LCD segment pin | ● | ● | ● |
| SEG6 | O | LCD segment pin | ● | ● | ● |
| SEG7 | O | LCD segment pin | ● | ● | ● |
| SEG8 | O | LCD segment pin | ● | ● | ● |
| SEG9 | O | LCD segment pin | ● | ● | ● |
| SEG10 | O | LCD segment pin | ● | ● | ● |
| SEG11 | O | LCD segment pin | ● | ● | ● |
| SEG12 | O | LCD segment pin | ● | ● | ● |
| SEG13 | O | LCD segment pin | ● | ● | ● |
| SEG14 | O | LCD segment pin | ● | ● | ● |
| SEG15 | O | LCD segment pin | ● | ● | ● |
| SEG16 | O | LCD segment pin | ● | ● | ● |
| SEG17 | O | LCD segment pin | ● | ● | ● |
| SEG18 | O | LCD segment pin | ● | ● | ● |
| SEG19 | O | LCD segment pin | ● | ● | ● |
| SEG20 | O | LCD segment pin | ● | ● | ● |
| SEG21 | O | LCD segment pin | ● | ● | ● |
| SEG22 | O | LCD segment pin | ● | ● | ● |
| SEG23 | O | LCD segment pin | ● | ● | ● |
| SEG24 | O | LCD segment pin | ● | ● | ● |
| SEG25 | O | LCD segment pin | ● | ● | ● |
| SEG26 | O | LCD segment pin | ● | ● | ● |
| SEG27 | O | LCD segment pin | ● | ● | ● |
| SEG28 | O | LCD segment pin | ● | ● | ● |
| SEG29 | O | LCD segment pin | ● | ● | ● |
| SEG30 | O | LCD segment pin | ● | ● | ● |
| SEG31 | O | LCD segment pin | ● | ● | ● |
| SEG32 | O | LCD segment pin | | ● | ● |
| SEG33 | O | LCD segment pin | | ● | ● |
| SEG34 | O | LCD segment pin | | ● | ● |
| SEG35 | O | LCD segment pin | | ● | ● |

| Pin name | Input/output | Function | ML610407 | ML610408 | ML610409 |
|----------|--------------|-----------------|----------|----------|----------|
| SEG36 | O | LCD segment pin | | | ● |
| SEG37 | O | LCD segment pin | | | ● |
| SEG38 | O | LCD segment pin | | | ● |
| SEG39 | O | LCD segment pin | | | ● |

22.2 Description of Registers

22.2.1 List of Registers

| Address | Name | Symbol (Byte) | Symbol (Word) | R/W | Size | Initial value |
|---------------------|--|----------------------|---------------|-----|------|---------------|
| 0F0F0H | Bias circuit control register | BIASCON | — | R/W | 8 | 38H |
| 0F0F2H | Display mode register 0 | DSPMOD0 | DSPMOD | R/W | 8/16 | 00H |
| 0F0F3H | Display mode register 1 | DSPMOD1 | | R/W | 8 | 00H |
| 0F0F4H | Display control register | DSPCON | — | R/W | 8 | 00H |
| 0F100H to 0F127H | Display register 00 to Display register 27 | DSPR00 to DSPR27 | — | R/W | 8 | Undefined |
| 0F400H to 0F427H | Display allocation register A | DS0C0A to DS39C0A | — | R/W | 8 | Undefined |
| 0F440H to 0F467H | | DS0C1A to DS39C1A | — | R/W | 8 | Undefined |
| 0F480H to 0F4A7H | | DS0C2A to DS39C2A | — | R/W | 8 | Undefined |
| 0F4C0H to 0F4E7H | | DS0C3A to DS39C3A | — | R/W | 8 | Undefined |
| 0F500H to 0F527H | | DS0C4A to DS39C4A | — | R/W | 8 | Undefined |
| 0F600H to 0F627H | Display allocation register B | DS0C0B to DS39C0B | — | R/W | 8 | Undefined |
| 0F640H to 0F667H | | DS0C1B to DS39C1B | — | R/W | 8 | Undefined |
| 0F680H to 0F6A7H | | DS0C2B to DS39C2B | — | R/W | 8 | Undefined |
| 0F6C0H to 0F6E7H | | DS0C3B to DS39C3B | — | R/W | 8 | Undefined |
| 0F700H to 0F727H | | DS0C4B to DS39C4B | — | R/W | 8 | Undefined |

22.2.2 Bias Circuit Control Register 0 (BIASCON)

Address: 0F0F0H
Access: R/W
Access size: 8-bit
Initial value: 38H

| | | | | | | | | |
|---------------|-----|-----|-------|-------|------|------|------|-----|
| | 7 | 6 | 5 | 4 | 3 | 2 | 1 | 0 |
| BIASCON | — | — | BSEL1 | BSEL0 | BSN2 | BSN1 | BSN0 | — |
| R/W | R/W | R/W | R/W | R/W | R/W | R/W | R/W | R/W |
| Initial value | 0 | 0 | 1 | 1 | 1 | 0 | 0 | 0 |

BIASCON is a special function register (SFR) to control the bias generation circuit.

[Description of Bits]

- **BSN2-BSN0** (bit 3 to 1)

The BSN2 to BSN0 bits are used to select a clock for multiplying the bias voltage in the bias generation circuit. LSCLK to 1/128LSCLK can be selected.

| BSN2 | BSN1 | BSN0 | Description |
|------|------|------|------------------------------------|
| 0 | 0 | 0 | 1/1 LSCLK (32kHz) |
| 0 | 0 | 1 | 1/2 LSCLK (16kHz) |
| 0 | 1 | 0 | 1/4 LSCLK (8kHz) |
| 0 | 1 | 1 | 1/8 LSCLK (4kHz) |
| 1 | 0 | 0 | 1/16 LSCLK (2 kHz) (initial value) |
| 1 | 0 | 1 | 1/32 LSCLK (1kHz) |
| 1 | 1 | 0 | 1/64 LSCLK (512Hz) |
| 1 | 1 | 1 | 1/128 LSCLK (256Hz) |

- **BSEL** (bit 5 to 4)

The BSEL bit is used to set the bias in the bias generation circuit. 1/2 bias or 1/3 bias can be selected.

| BSEL1 | BSEL0 | Description |
|-------|-------|--------------------------|
| 0 | 0 | 1/3 bias |
| 0 | 1 | Setting prohibited |
| 1 | 0 | Setting prohibited |
| 1 | 1 | 1/2 bias (initial value) |

22.2.3 Display Mode Register 0 (DSPMOD0)

Address: 0F0F2H
 Access: R/W
 Access size: 8/16 bit
 Initial value: 00H

| | | | | | | | | |
|---------------|-----|------|------|-----|-----|-------|-------|-------|
| | 7 | 6 | 5 | 4 | 3 | 2 | 1 | 0 |
| DSPMOD0 | — | FRM1 | FRM0 | — | — | DUTY2 | DUTY1 | DUTY0 |
| R/W | R/W | R/W | R/W | R/W | R/W | R/W | R/W | R/W |
| Initial value | 0 | 0 | 0 | 0 | 0 | 0 | 0 | 0 |

DSPMOD0 is a special function register (SFR) to control the display mode of the LCD drivers.

[Description of Bits]

- **DUTY2 to DUTY0** (bit 2 to 0)

The DUTY2 to DUTY0 bits are used to specify the duty in 5 steps (1/1 to 1/5). The numbers of commons/segments are determined according to the duty setting.

| Product (ML610...) | | | Common to all products | 407 | 408 | 409 |
|--------------------|-------|-------|--------------------------|----------------------------|--------|--------|
| DUTY2 | DUTY1 | DUTY0 | Duty | Number of commons/segments | | |
| 0 | 0 | 0 | 1/1 duty (initial value) | 2c-32s | 2c-36s | 2c-40s |
| 0 | 0 | 1 | 1/2 duty | 2c-32s | 2c-36s | 2c-40s |
| 0 | 1 | 0 | 1/3 duty | 3c-31s | 3c-35s | 3c-39s |
| 0 | 1 | 1 | 1/4 duty | 4c-30s | 4c-34s | 4c-38s |
| 1 | * | * | 1/5 duty | 5c-29s | 5c-33s | 5c-37s |

- **FRM1-FRM0** (bit 6, 5)

The FRM1 to FRM0 bits are used to select a frame frequency of the LCD drivers.

The reference frequency of a frame frequency (LLSCLK = 32.768 kHz) is selectable from 64 Hz, 73 Hz, 85 Hz, or 102 Hz.

| FRM1 | FRM0 | Description |
|------|------|--|
| 0 | 0 | Reference frequency: 64 Hz (initial value) |
| 0 | 1 | Reference frequency: 73 Hz |
| 1 | 0 | Reference frequency: 85 Hz |
| 1 | 1 | Reference frequency: 102 Hz |

The frame frequency for each duty is listed in Table 22-2.

Table 22-2 Frame Frequency for Each Duty

| Duty | Frame frequency [Hz] | | | |
|----------|-----------------------------|-------------------------------|-------------------------------|--------------------------------|
| | Reference frequency 64Hz | Reference frequency: 73 Hz | Reference frequency: 85 Hz | Reference frequency: 102 Hz |
| 1/1 duty | 64.00 | 73.14 | 85.33 | 102.40 |
| 1/2 duty | 64.00 | 73.14 | 85.33 | 102.40 |
| 1/3 duty | 64.25 | 73.31 | 85.33 | 103.04 |
| 1/4 duty | 64.00 | 73.14 | 85.33 | 102.40 |
| 1/5 duty | 64.25 | 73.64 | 86.23 | 102.40 |

22.2.4 Display Mode Register 1 (DSPMOD1)

Address: 0F0F3H
 Access: R/W
 Access size: 8-bit
 Initial value: 00H

| | | | | | | | | |
|---------------|-----|-----|-----|-----|-----|------|-----|-----|
| | 7 | 6 | 5 | 4 | 3 | 2 | 1 | 0 |
| DSPMOD1 | — | — | — | — | — | DASN | — | — |
| R/W | R/W | R/W | R/W | R/W | R/W | R/W | R/W | R/W |
| Initial value | 0 | 0 | 0 | 0 | 0 | 0 | 0 | 0 |

DSPMOD1 is a special function register (SFR) to control the display mode of the LCD drivers.
 Use DSPMOD1 to select to use or unuse the programmable display allocation function for the display registers.

[Description of Bits]

- **DASN** (bit 2)

The DASN bit is used to control the operation of the programmable display allocation function.
 See Sections 22.2.6, 22.2.7, and 22.3.3 for the programmable display allocation function.

| DASN | Description |
|------|--|
| 0 | Not use Programmable display allocation function (initial value) |
| 1 | Use Programmable display allocation function |

22.2.5 Display Control Register (DSPCON)

Address: 0F0F4H
 Access: R/W
 Access size: 8-bit
 Initial value: 00H

| | | | | | | | | |
|---------------|-----|-----|-----|-----|-----|-----|------|------|
| | 7 | 6 | 5 | 4 | 3 | 2 | 1 | 0 |
| DSPCON | — | — | — | — | — | — | LMD1 | LMD0 |
| R/W | R/W | R/W | R/W | R/W | R/W | R/W | R/W | R/W |
| Initial value | 0 | 0 | 0 | 0 | 0 | 0 | 0 | 0 |

DSPCON is a special function register (SFR) to control the LCD drivers.

[Description of Bits]

- **LMD1-LMD0** (bit 1, 0)

The LMD1 and LMD0 bits are used to select an LCD display mode.

LCD stop mode, all LCDs off mode, LCD display mode, and all LCDs on mode can be selected.

In LCD stop mode, V_{ss} level is output to all the common drivers and segment drivers. The charge and discharge current to and from the display panel can be stopped.

In all LCDs off mode, off waveform is output to all the segment drivers irrespective of the contents of the display registers.

In LCD display mode, the contents of the display registers are output to each segment driver.

In all LCDs on mode, on waveform is output to all the segment drivers irrespective of the contents of the display registers.

| LMD1 | LMD0 | Description |
|------|------|-------------------------------|
| 0 | 0 | LCD stop mode (initial value) |
| 0 | 1 | All LCDs off mode |
| 1 | 0 | LCD display mode |
| 1 | 1 | All LCDs on mode |

22.2.6 Display Allocation Register A (DS0C0A to DS39C4A)

Address: 0F400H to 0F427H, 0F440H to 0F467H, 0F480H to 0F4A7H, 0F4C0H to 0F4E7H, 0F500H to 0F527H
 Access: R/W
 Access size: 8-bit
 Initial value: Undefined

| | 7 | 6 | 5 | 4 | 3 | 2 | 1 | 0 |
|---------------|-----|-----|-----|-----|-----|-----|-----|-----|
| DSmCnA | — | — | a5 | a4 | a3 | a2 | a1 | a0 |
| R/W | R/W | R/W | R/W | R/W | R/W | R/W | R/W | R/W |
| Initial value | 0 | 0 | 0 | x | x | x | x | x |

DSmCnA (m = 0 to 39, n = 0 to 4) are special function registers (SFRs) that are used for the programmable display allocation function.

Each valid bit of DSmCnA becomes undefined at system reset.

Table 22-3 shows a list of the display allocation register A.

[Description of Bits]

- **a5 to a0** (bit 5 to 0)

The a5 to a0 bits of DSmCnA (m = 0 to 39, n = 0 to 4) are used to select the addresses of the display registers (DSPR00 to 27) that are output to common n of segment m.

Set DSmCnA when the DASN bit of the display mode register 1 (DSPMOD1) is "0". When the DASN bit is "1", access from the CPU is invalid.

Table 22-3 Display Allocation Register A

| Segment | Common | Register name | Address | bit7 | bit6 | bit5 | bit4 | bit3 | bit2 | bit1 | bit0 | R/W |
|---------|--------|---------------|---------|------|------|------|------|------|------|------|------|-----|
| SEG0 | COM0 | DS0C0A | 0F400H | — | — | — | a4 | a3 | a2 | a1 | a0 | R/W |
| SEG1 | COM0 | DS1C0A | 0F401H | — | — | — | a4 | a3 | a2 | a1 | a0 | R/W |
| SEG2 | COM0 | DS2C0A | 0F402H | — | — | — | a4 | a3 | a2 | a1 | a0 | R/W |
| SEG3 | COM0 | DS3C0A | 0F403H | — | — | — | a4 | a3 | a2 | a1 | a0 | R/W |
| : | : | : | : | : | : | : | : | : | : | : | : | : |
| SEG39 | COM0 | DS39C0A | 0F427H | — | — | — | a4 | a3 | a2 | a1 | a0 | R/W |
| SEG0 | COM1 | DS0C1A | 0F440H | — | — | — | a4 | a3 | a2 | a1 | a0 | R/W |
| : | : | : | : | : | : | : | : | : | : | : | : | : |
| SEG39 | COM1 | DS39C1A | 0F467H | — | — | — | a4 | a3 | a2 | a1 | a0 | R/W |
| SEG0 | COM2 | DS0C2A | 0F480H | — | — | — | a4 | a3 | a2 | a1 | a0 | R/W |
| : | : | : | : | : | : | : | : | : | : | : | : | : |
| SEG39 | COM2 | DS39C2A | 0F4A7H | — | — | — | a4 | a3 | a2 | a1 | a0 | R/W |
| SEG0 | COM3 | DS0C3A | 0F4C0H | — | — | — | a4 | a3 | a2 | a1 | a0 | R/W |
| : | : | : | : | : | : | : | : | : | : | : | : | : |
| SEG39 | COM3 | DS39C3A | 0F4E7H | — | — | — | a4 | a3 | a2 | a1 | a0 | R/W |
| SEG0 | COM4 | DS0C4A | 0F500H | — | — | — | a4 | a3 | a2 | a1 | a0 | R/W |
| : | : | : | : | : | : | : | : | : | : | : | : | : |
| SEG39 | COM4 | DS39C4A | 0F527H | — | — | — | a4 | a3 | a2 | a1 | a0 | R/W |

22.2.7 Display Allocation Register B (DS39C4B to DS49C7B)

Address: 0F600H to 0F627H, 0F640H to 0F667H, 0F680H to 0F6A7H, 0F6C0H to 0F6E7H, 0F700H to 0F727H

Access: R/W

Access size: 8-bit

Initial value: Undefined

| | | | | | | | | |
|--------------------|-----|-----|-----|-----|-----|-----|-----|-----|
| | 7 | 6 | 5 | 4 | 3 | 2 | 1 | 0 |
| D _{SmCnB} | — | — | — | — | — | b2 | b1 | b0 |
| R/W | R/W | R/W | R/W | R/W | R/W | R/W | R/W | R/W |
| Initial value | 0 | 0 | 0 | 0 | 0 | x | x | x |

D_{SmCnB} (m= 0 to 39, n = 0 to 4) are special function registers (SFRs) to store segment allocation data.

Each valid bit of D_{SmCnB} becomes undefined at system reset.

Table 22-4 shows a list of the display allocation register B.

[Description of Bits]

- **b2-b0** (bit 2 to 0)

The b2 to b0 bits of D_{SmCnB} (m = 0 to 39, n = 0 to 4) are used to set the bits of the display registers (DS_{PR00} to 27) that are output to common n of segment m.

Set D_{SmCnB} when the D_{ASN} bit of the display control register 0 (D_{SPCON0}) is "0".

When the D_{ASN} bit is "1", access from the CPU is invalid.

| b2 | b1 | b0 | Description |
|----|----|----|---------------|
| 0 | 0 | 0 | Selects bit 0 |
| 0 | 0 | 1 | Selects bit 1 |
| 0 | 1 | 0 | Selects bit 2 |
| 0 | 1 | 1 | Selects bit 3 |
| 1 | 0 | 0 | Selects bit 4 |
| 1 | 0 | 1 | Selects bit 5 |
| 1 | 1 | 0 | Selects bit 6 |
| 1 | 1 | 1 | Selects bit 7 |

Table 22-4 Display Allocation Register B

| Segment | Common | Register name | Address | bit7 | bit6 | bit5 | bit4 | bit3 | bit2 | bit1 | bit0 | R/W |
|---------|--------|---------------|---------|------|------|------|------|------|------|------|------|-----|
| SEG0 | COM0 | DS0C0B | 0F600H | — | — | — | — | — | b2 | b1 | b0 | R/W |
| SEG1 | COM0 | DS1C0B | 0F601H | — | — | — | — | — | b2 | b1 | b0 | R/W |
| SEG2 | COM0 | DS2C0B | 0F602H | — | — | — | — | — | b2 | b1 | b0 | R/W |
| SEG3 | COM0 | DS3C0B | 0F603H | — | — | — | — | — | b2 | b1 | b0 | R/W |
| : | : | : | : | : | : | : | : | : | : | : | : | : |
| SEG39 | COM0 | DS39C0B | 0F627H | — | — | — | — | — | b2 | b1 | b0 | R/W |
| SEG0 | COM1 | DS0C1B | 0F640H | — | — | — | — | — | b2 | b1 | b0 | R/W |
| : | : | : | : | : | : | : | : | : | : | : | : | : |
| SEG39 | COM1 | DS39C1B | 0F667H | — | — | — | — | — | b2 | b1 | b0 | R/W |
| SEG0 | COM2 | DS0C2B | 0F680H | — | — | — | — | — | b2 | b1 | b0 | R/W |
| : | : | : | : | : | : | : | : | : | : | : | : | : |
| SEG39 | COM2 | DS39C2B | 0F6A7H | — | — | — | — | — | b2 | b1 | b0 | R/W |
| SEG0 | COM3 | DS0C3B | 0F6C0H | — | — | — | — | — | b2 | b1 | b0 | R/W |
| : | : | : | : | : | : | : | : | : | : | : | : | : |
| SEG39 | COM3 | DS39C3B | 0F6E7H | — | — | — | — | — | b2 | b1 | b0 | R/W |
| SEG0 | COM4 | DS0C4B | 0F700H | — | — | — | — | — | b2 | b1 | b0 | R/W |
| : | : | : | : | : | : | : | : | : | : | : | : | : |
| SEG39 | COM4 | DS39C4B | 0F727H | — | — | — | — | — | b2 | b1 | b0 | R/W |

22.2.8 Display Registers (DSPR00 to DSPR27)

Address: 0F100H to 0F127H
 Access: R/W
 Access size: 8-bit
 Initial value: Undefined

| | | | | | | | | |
|---------------|-----|-----|-----|-----|-----|-----|-----|-----|
| | 7 | 6 | 5 | 4 | 3 | 2 | 1 | 0 |
| DSPRxx | c7 | c6 | c5 | c4 | c3 | c2 | c1 | c0 |
| R/W | R/W | R/W | R/W | R/W | R/W | R/W | R/W | R/W |
| Initial value | x | x | x | x | x | x | x | x |

DSPRxx (xx = 00 to 27H) are special function registers (SFRs) to store display data.
 Each valid bit of DSPRxx becomes undefined at system reset.
 The display registers that are not used for LCD display can be used for data memories.
 Set data in DSPRxx before setting LCD display mode.
 The c4 to c0 values are used when the programmable display allocation function is not used.

[Description of Bits]

- **c7 to c0** (bit 7 to 0)
 The c7 to c0 bits are used to set display data.

| c7~c0 | Description |
|-------|--------------|
| 0 | off waveform |
| 1 | on waveform |

Table 22-5 List of Display Registers

| Register name | Address | Corresponding segment | bit7 | bit6 | bit5 | bit4 | bit3 | bit2 | bit1 | bit0 | R/W |
|---------------|---------|-----------------------|------|------|------|------|------|------|------|------|-----|
| DSPR00 | 0F100H | SEG0 | c7 | c6 | c5 | c4 | c3 | c2 | c1 | c0 | R/W |
| DSPR01 | 0F101H | SEG1 | c7 | c6 | c5 | c4 | c3 | c2 | c1 | c0 | R/W |
| DSPR02 | 0F102H | SEG2 | c7 | c6 | c5 | c4 | c3 | c2 | c1 | c0 | R/W |
| DSPR03 | 0F103H | SEG3 | c7 | c6 | c5 | c4 | c3 | c2 | c1 | c0 | R/W |
| DSPR04 | 0F104H | SEG4 | c7 | c6 | c5 | c4 | c3 | c2 | c1 | c0 | R/W |
| DSPR05 | 0F105H | SEG5 | c7 | c6 | c5 | c4 | c3 | c2 | c1 | c0 | R/W |
| DSPR06 | 0F106H | SEG6 | c7 | c6 | c5 | c4 | c3 | c2 | c1 | c0 | R/W |
| DSPR07 | 0F107H | SEG7 | c7 | c6 | c5 | c4 | c3 | c2 | c1 | c0 | R/W |
| DSPR08 | 0F108H | SEG8 | c7 | c6 | c5 | c4 | c3 | c2 | c1 | c0 | R/W |
| DSPR09 | 0F109H | SEG9 | c7 | c6 | c5 | c4 | c3 | c2 | c1 | c0 | R/W |
| DSPR0A | 0F10AH | SEG10 | c7 | c6 | c5 | c4 | c3 | c2 | c1 | c0 | R/W |
| DSPR0B | 0F10BH | SEG11 | c7 | c6 | c5 | c4 | c3 | c2 | c1 | c0 | R/W |
| DSPR0C | 0F10CH | SEG12 | c7 | c6 | c5 | c4 | c3 | c2 | c1 | c0 | R/W |
| DSPR0D | 0F10DH | SEG13 | c7 | c6 | c5 | c4 | c3 | c2 | c1 | c0 | R/W |
| DSPR0E | 0F10EH | SEG14 | c7 | c6 | c5 | c4 | c3 | c2 | c1 | c0 | R/W |
| DSPR0F | 0F10FH | SEG15 | c7 | c6 | c5 | c4 | c3 | c2 | c1 | c0 | R/W |
| DSPR10 | 0F110H | SEG16 | c7 | c6 | c5 | c4 | c3 | c2 | c1 | c0 | R/W |
| DSPR11 | 0F111H | SEG17 | c7 | c6 | c5 | c4 | c3 | c2 | c1 | c0 | R/W |
| DSPR12 | 0F112H | SEG18 | c7 | c6 | c5 | c4 | c3 | c2 | c1 | c0 | R/W |
| DSPR13 | 0F113H | SEG19 | c7 | c6 | c5 | c4 | c3 | c2 | c1 | c0 | R/W |
| DSPR14 | 0F114H | SEG20 | c7 | c6 | c5 | c4 | c3 | c2 | c1 | c0 | R/W |
| DSPR15 | 0F115H | SEG21 | c7 | c6 | c5 | c4 | c3 | c2 | c1 | c0 | R/W |
| DSPR16 | 0F116H | SEG22 | c7 | c6 | c5 | c4 | c3 | c2 | c1 | c0 | R/W |
| DSPR17 | 0F117H | SEG23 | c7 | c6 | c5 | c4 | c3 | c2 | c1 | c0 | R/W |
| DSPR18 | 0F118H | SEG24 | c7 | c6 | c5 | c4 | c3 | c2 | c1 | c0 | R/W |
| DSPR19 | 0F119H | SEG25 | c7 | c6 | c5 | c4 | c3 | c2 | c1 | c0 | R/W |
| DSPR1A | 0F11AH | SEG26 | c7 | c6 | c5 | c4 | c3 | c2 | c1 | c0 | R/W |
| DSPR1B | 0F11BH | SEG27 | c7 | c6 | c5 | c4 | c3 | c2 | c1 | c0 | R/W |
| DSPR1C | 0F11CH | SEG28 | c7 | c6 | c5 | c4 | c3 | c2 | c1 | c0 | R/W |
| DSPR1D | 0F11DH | SEG29 | c7 | c6 | c5 | c4 | c3 | c2 | c1 | c0 | R/W |
| DSPR1E | 0F11EH | SEG30 | c7 | c6 | c5 | c4 | c3 | c2 | c1 | c0 | R/W |
| DSPR1F | 0F11FH | SEG31 | c7 | c6 | c5 | c4 | c3 | c2 | c1 | c0 | R/W |
| DSPR20 | 0F120H | SEG32 | c7 | c6 | c5 | c4 | c3 | c2 | c1 | c0 | R/W |
| DSPR21 | 0F121H | SEG33 | c7 | c6 | c5 | c4 | c3 | c2 | c1 | c0 | R/W |
| DSPR22 | 0F122H | SEG34 | c7 | c6 | c5 | c4 | c3 | c2 | c1 | c0 | R/W |
| DSPR23 | 0F123H | SEG35 | c7 | c6 | c5 | c4 | c3 | c2 | c1 | c0 | R/W |
| DSPR24 | 0F124H | SEG36 | c7 | c6 | c5 | c4 | c3 | c2 | c1 | c0 | R/W |
| DSPR25 | 0F125H | SEG37 | c7 | c6 | c5 | c4 | c3 | c2 | c1 | c0 | R/W |
| DSPR26 | 0F126H | SEG38 | c7 | c6 | c5 | c4 | c3 | c2 | c1 | c0 | R/W |
| DSPR27 | 0F127H | SEG39 | c7 | c6 | c5 | c4 | c3 | c2 | c1 | c0 | R/W |

22.3 Description of Operation

22.3.1 Operation of LCD Drivers and Bias Generation Circuit

Figure 22-6 shows the operation of the LCD drivers and the bias generation circuit.

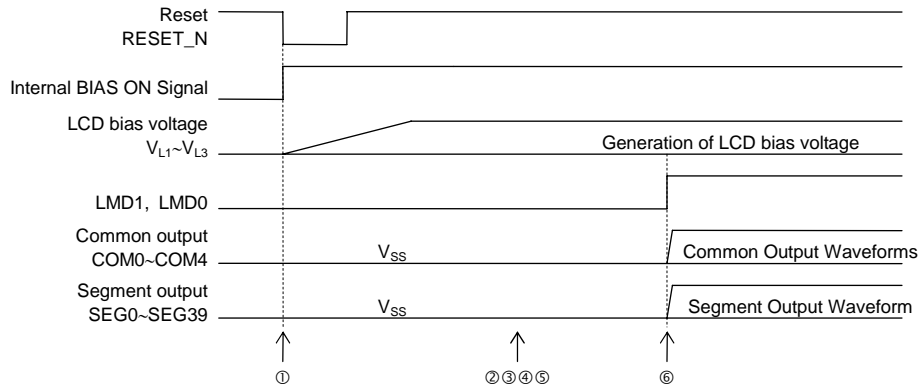
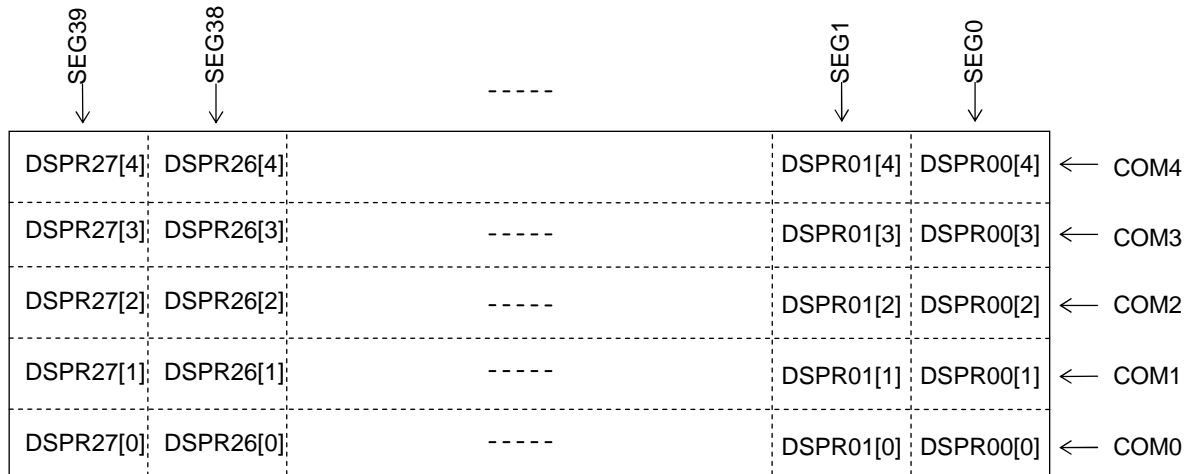

Figure 22-6 Operation of LCD Drivers and Bias Generation Circuit

- ① System reset causes the bias generation circuit and the LCD drivers to stop operation and V_{SS} level to be output to each of the common and segment pins.
- ② By using the bias circuit control register (BIASCON), select 1/2 bias or 1/3 bias and select the bias voltage multiplying clock.
- ③ When the programmable display allocation function is used, set LCD allocation data in the display allocation registers (DS0C0 to DS39C4).
- ④ Set a frame frequency and a duty by using the display mode register 0 (DSPMOD0). When using the programmable display allocation function, set the DSPMOD1 register's DASN bit to "1". When not using the programmable display allocation function, set the DSPMOD1 register's DASN bit to "0".
- ⑤ Set display data in the display registers (DSPR00 to DSPR27).
- ⑥ On the display control register (DSPCON), set the LMD1 and LMD0 bits to the display mode. (Display waveform is output to each segment pin.)

22.3.2 Segment Mapping When the Programmable Display Allocation Function is Not Used

The following shows the segment map of the display registers (DSPR00 to 27) when the programmable display allocation function is not used (DSPMOD1 register's DASN bit = "0"):



For ML610409

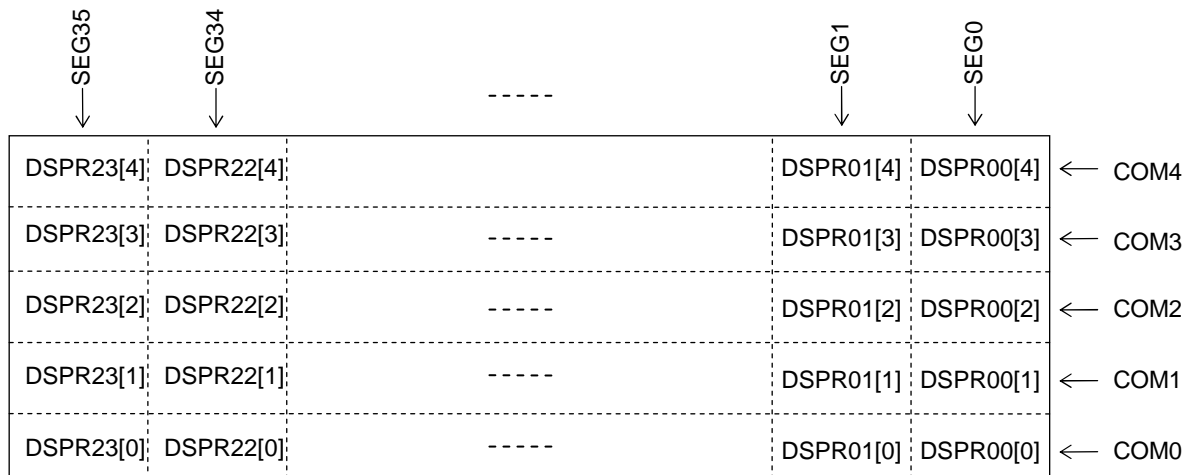

For ML610408

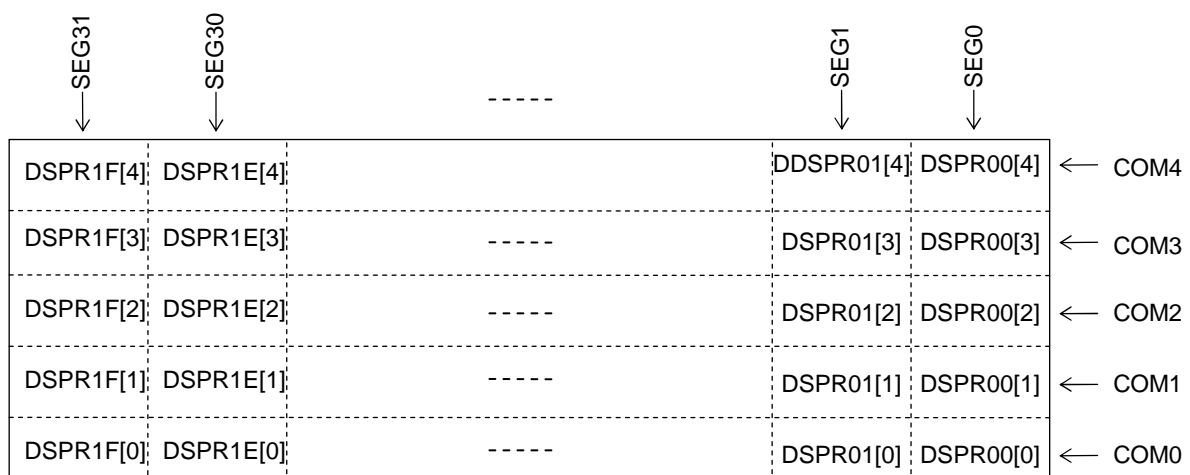

For ML610407

Figure 22-7 Segment Map Configuration Diagram

22.3.3 Segment Mapping When the Programmable Display Allocation Function is Used

When the programmable display allocation function is used (DASN bit of DSPMOD1 register is "1"), the segment map of the display registers (DSPR00 to 27) can be programmatically changed using the display allocation registers (DSmCn: m = 0 to 39, n = 0 to 4).

Figure 22-8 shows the configuration when using the programmable display allocation function.

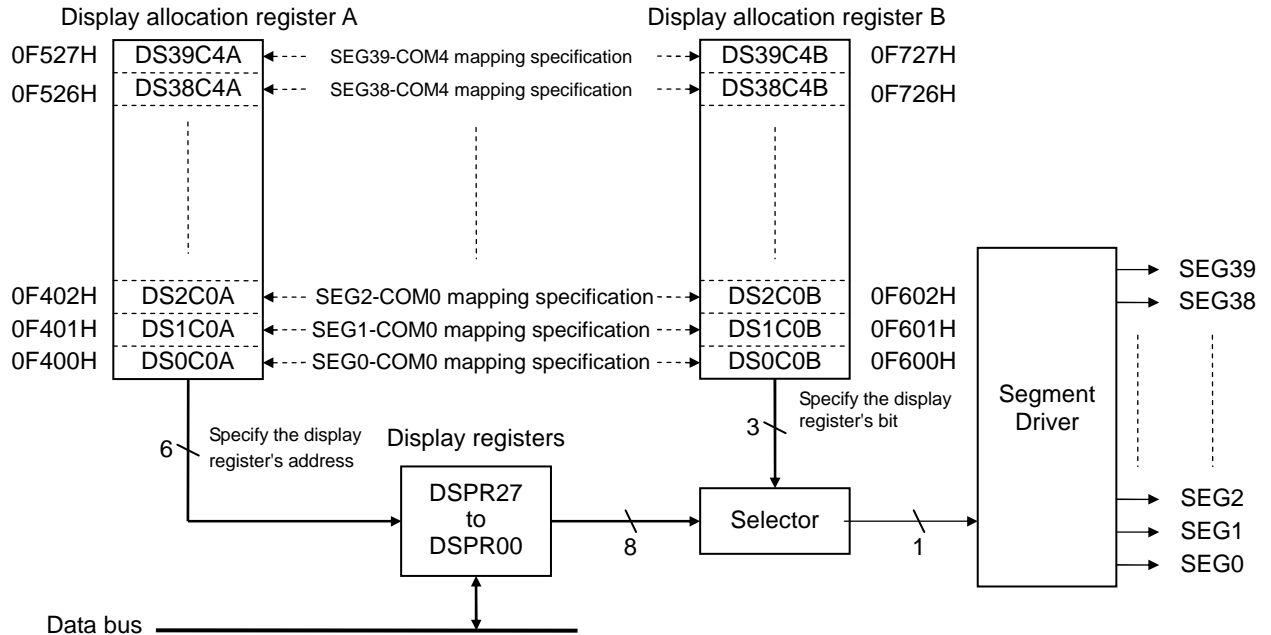
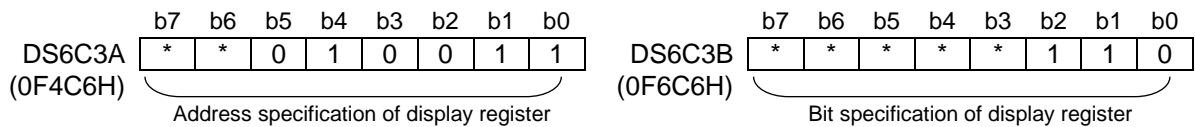

Figure 22-8 Configuration When Using the Programmable Display Allocation Function

In the display allocation register A (DSmCnA: m = 0 to 39, n = 0 to 4), set the address (00H to 27H) of the display register (DSPR00 to DSPR27) that is output to the common n of the segment n. In display allocation register B (DSmCnB: m = 0 to 39, n = 0 to 4), set the bits of the display register (DSPR00 to DSPR27) that is output to the common n of the segment m.

For instance, to display bit 6 of display register 13 (DSPR13) to the common 3 of the segment 6, set as follows.



"*" indicates an arbitrary value.

[Note]

- Set display allocation data to display allocation registers when the DASN bit of display mode register 1 (DSPMOD1) is "0". When the DASN bit is "1", access from the CPU is invalid.

22.3.4 Common Output Waveforms

Figure 22-9 shows the common output waveform at 1/5 duty (5 commons) and 1/3 bias.

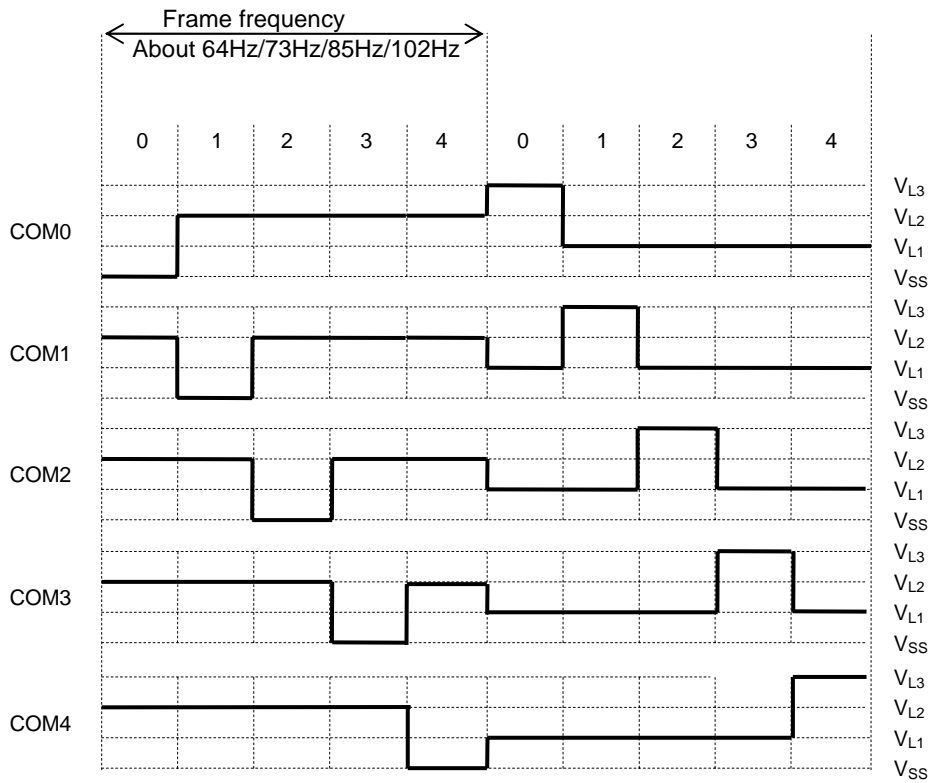

Figure 22-9 Common Output Waveform at 1/5 Duty (5 Commons) and 1/3 Bias

Figure 22-10 shows the common output waveform at 1/5 duty (5 commons) and 1/2 bias.

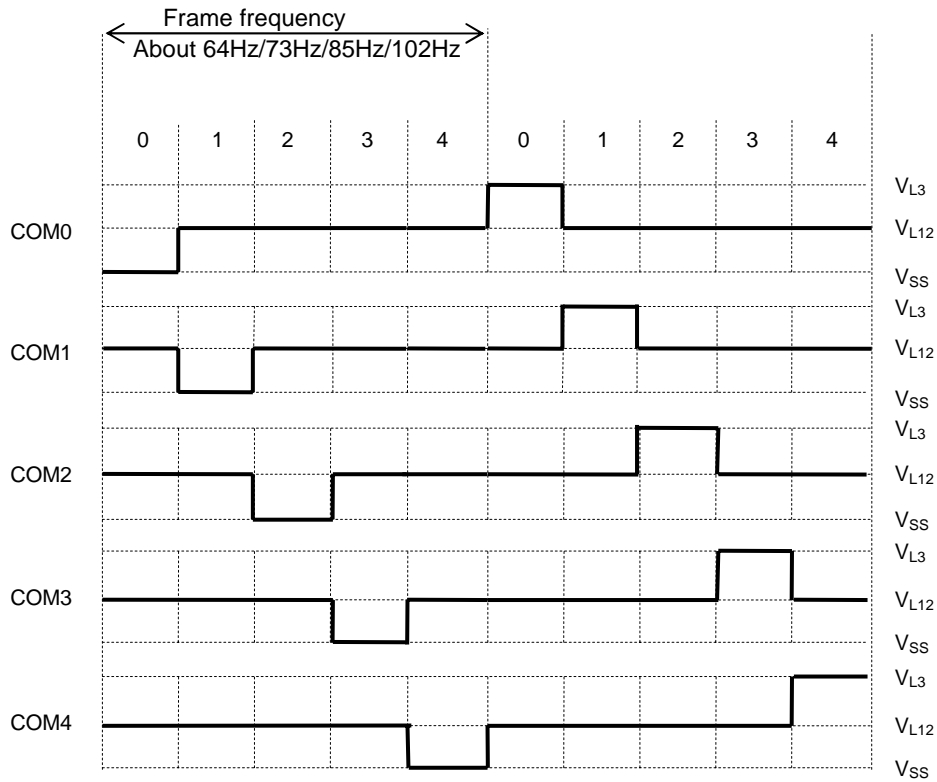

Figure 22-10 Common Output Waveform at 1/5 Duty (5 Commons) and 1/2 Bias

22.3.5 Segment Output Waveform

Figure 22-11 shows the segment output waveform at 1/5 duty (5 commons) and 1/3 bias.

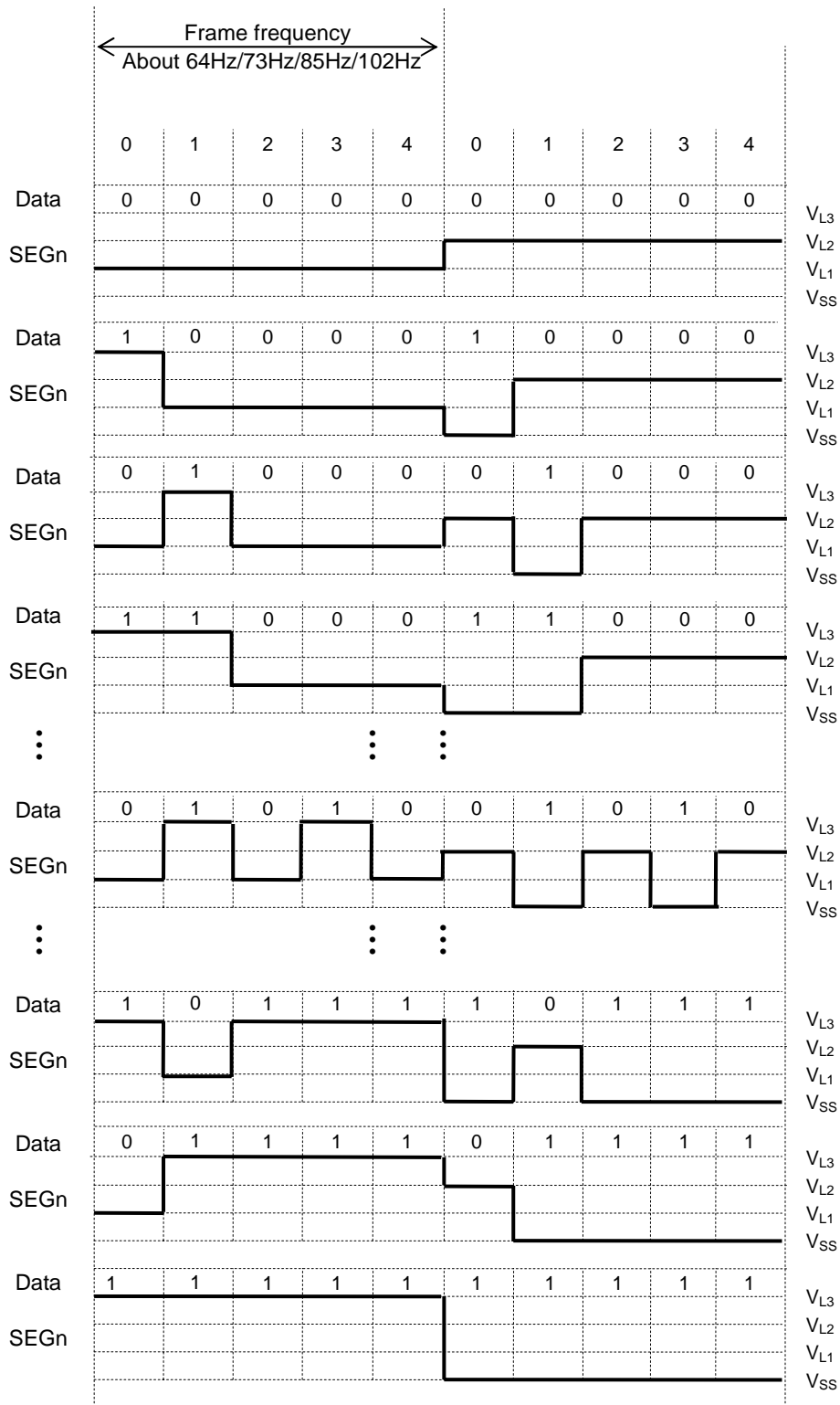

Figure 22-11 Segment Output Waveform at 1/5 Duty (5 Commons) and 1/3 Bias

Figure 22-12 shows the segment output waveform at 1/5 duty (5 commons) and 1/2 bias.

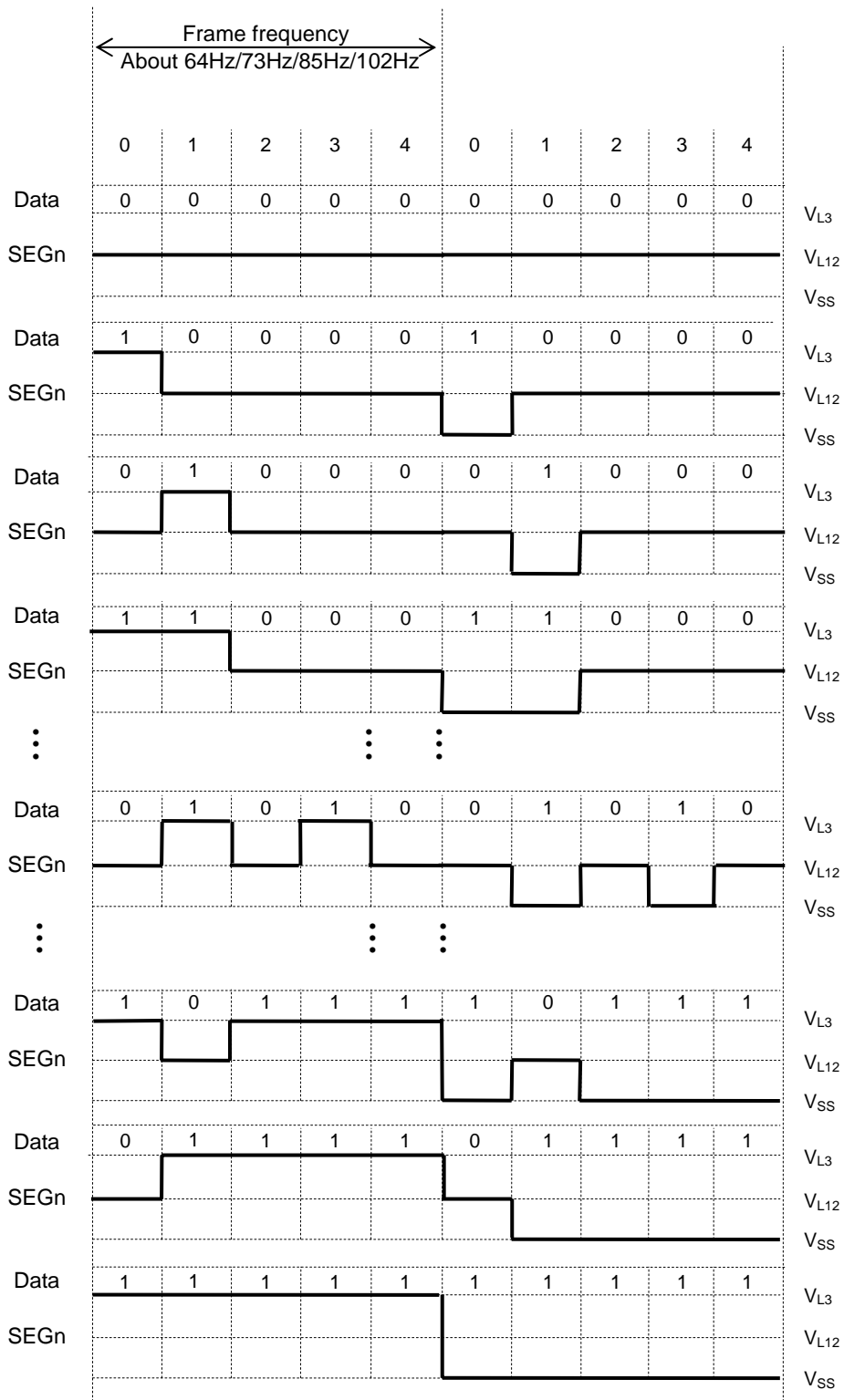

Figure 22-12 Segment Output Waveform at 1/5 Duty (5 Commons) and 1/2 Bias

Power Supply Circuit

23. Power Supply Circuit

23.1 Overview

This LSI includes a voltage regulator circuit for internal logic (VRL).

The VRL outputs the operating voltage, V_{DDL} , of the internal logic circuit, program memory, RAM, low-speed oscillation, etc.

For the circuit configuration of the power supplies for LCD (V_{L1} to V_{L3}), see Chapter 22, "LCD Driver".

23.1.1 Features

- The VRL outputs the operating voltage, V_{DDL} , of the internal logic circuit, program memory, RAM, low-speed oscillation, etc.

23.1.2 Configuration

Figure 23-1 shows the configuration of the power supply circuit.

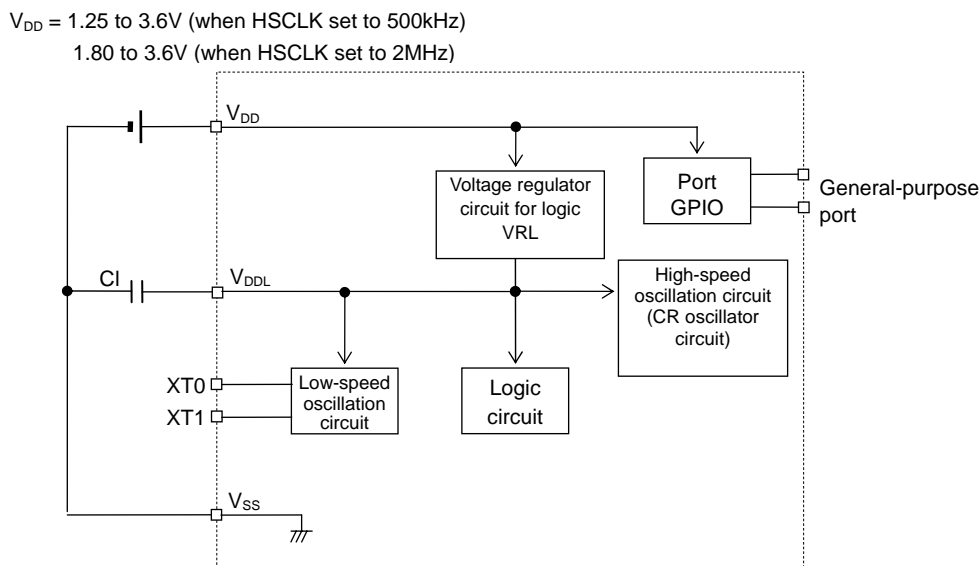

Figure 23-1 Configuration of Power Supply Circuit

23.1.3 List of Pins

| Pin name | I/O | Function |
|-----------|-----|--|
| V_{DDL} | — | Positive power supply pin for the internal logic circuits The V_{DDL} voltage becomes approximately 1.2 V at a system reset. At a system reset, the oscillation frequency of the high-speed oscillation circuit (CR oscillator circuit) is set to 500 kHz. When the oscillation frequency of the high-speed oscillator circuit (CR oscillation circuit) is set to 2 MHz, the V_{DDL} voltage becomes approximately 1.5 V. |

Mask Option

24. Mask Option

24.1 Overview

In this LSI, the low-speed oscillation stop detection enable/disable is selected as a mask option.

The low-speed oscillation stop detection enable/disable is decided by the test area data of the program memory space when the LSI is manufactured.

For the Mask-Option, see Chapter 3, “Reset Function”.

For the test area data of the program memory space, see Chapter 2, “CPU and Memory Space”.

For the Mask ROM version emulation function, see “ML610Q407 user's manual : Chapter 25 Mask ROM Version Emulation Function”.

24.1.1 Features

- The low-speed oscillation stop detection enable/disable is selected as a mask option.

Appendixes

Appendix A Registers

| Address | Name | Symbol (Byte) | Symbol (Word) | R/W | Size | Initial value |
|---------|---|---------------|---------------|-----|------|---------------|
| 0F000H | Data segment register | DSR | — | R/W | 8 | 00H |
| 0F001H | Reset status register | RSTAT | — | R/W | 8 | Undefined |
| 0F002H | Frequency control register 0 | FCON0 | FCON | R/W | 8/16 | 33H |
| 0F003H | Frequency control register 1 | FCON1 | | R/W | 8 | 00H |
| 0F008H | Stop code acceptor | STPACP | — | W | 8 | Undefined |
| 0F009H | Standby control register | SBYCON | — | W | 8 | 00H |
| 0F00AH | Low-speed time base counter register | LTBR | — | R/W | 8 | 00H |
| 0F00BH | High-speed time base counter frequency divide register | HTBDR | — | R/W | 8 | 00H |
| 0F00CH | Low-speed time base counter frequency adjustment register L | LTBADJL | LTBADJ | R/W | 8/16 | 00H |
| 0F00DH | Low-speed time base counter frequency adjustment register H | LTBADJH | | R/W | 8 | 00H |
| 0F00EH | Watchdog timer control register | WDTCON | — | R/W | 8 | 00H |
| 0F00FH | Watchdog timer mode register | WDTMOD | — | R/W | 8 | 02H |
| 0F011H | Interrupt enable register 1 | IE1 | — | R/W | 8 | 00H |
| 0F012H | Interrupt enable register 2 | IE2 | — | R/W | 8 | 00H |
| 0F013H | Interrupt enable register 3 | IE3 | — | R/W | 8 | 00H |
| 0F014H | Interrupt enable register 4 | IE4 | — | R/W | 8 | 00H |
| 0F015H | Interrupt enable register 5 | IE5 | — | R/W | 8 | 00H |
| 0F016H | Interrupt enable register 6 | IE6 | — | R/W | 8 | 00H |
| 0F017H | Interrupt enable register 7 | IE7 | — | R/W | 8 | 00H |
| 0F018H | Interrupt request register 0 | IRQ0 | — | R/W | 8 | 00H |
| 0F019H | Interrupt request register 1 | IRQ1 | — | R/W | 8 | 00H |
| 0F01AH | Interrupt request register 2 | IRQ2 | — | R/W | 8 | 00H |
| 0F01BH | Interrupt request register 3 | IRQ3 | — | R/W | 8 | 00H |
| 0F01CH | Interrupt request register 4 | IRQ4 | — | R/W | 8 | 00H |
| 0F01DH | Interrupt request register 5 | IRQ5 | — | R/W | 8 | 00H |
| 0F01EH | Interrupt request register 6 | IRQ6 | — | R/W | 8 | 00H |
| 0F01FH | Interrupt request register 7 | IRQ7 | — | R/W | 8 | 00H |
| 0F020H | External interrupt control register 0 | EXICON0 | — | R/W | 8 | 00H |
| 0F021H | External interrupt control register 1 | EXICON1 | — | R/W | 8 | 00H |
| 0F022H | External interrupt control register 2 | EXICON2 | — | R/W | 8 | 00H |
| 0F028H | Block control register 0 | BLKCON0 | — | R/W | 8 | 00H |
| 0F029H | Block control register 1 | BLKCON1 | — | R/W | 8 | 00H |
| 0F02AH | Block control register 2 | BLKCON2 | — | R/W | 8 | 00H |
| 0F02BH | Block control register 3 | BLKCON3 | — | R/W | 8 | 00H |
| 0F02CH | Block control register 4 | BLKCON4 | — | R/W | 8 | 00H |
| 0F030H | Timer 0 data register | TM0D | TM0DC | R/W | 8/16 | 0FFH |
| 0F031H | Timer 0 counter register | TM0C | | R/W | 8 | 00H |
| 0F032H | Timer 0 control register 0 | TM0CON0 | TM0CON | R/W | 8/16 | 00H |
| 0F033H | Timer 0 control register 1 | TM0CON1 | | R/W | 8 | 00H |
| 0F034H | Timer 1 data register | TM1D | TM1DC | R/W | 8/16 | 0FFH |
| 0F035H | Timer 1 counter register | TM1C | | R/W | 8 | 00H |
| 0F036H | Timer 1 control register 0 | TM1CON0 | TM1CON | R/W | 8/16 | 00H |

| Address | Name | Symbol (Byte) | Symbol (Word) | R/W | Size | Initial value |
|---------|---------------------------------|------------------|------------------|-----|------|------------------|
| 0F037H | Timer 1 control register 1 | TM1CON1 | | R/W | 8 | 00H |
| 0F038H | Timer 2 data register | TM2D | TM2DC | R/W | 8/16 | 0FFH |
| 0F039H | Timer 2 counter register | TM2C | | R/W | 8 | 00H |
| 0F03AH | Timer 2 control register 0 | TM2CON0 | TM2CON | R/W | 8/16 | 00H |
| 0F03BH | Timer 2 control register 1 | TM2CON1 | | R/W | 8 | 00H |
| 0F03CH | Timer 3 data register | TM3D | TM3DC | R/W | 8/16 | 0FFH |
| 0F03DH | Timer 3 counter register | TM3C | | R/W | 8 | 00H |
| 0F03EH | Timer 3 control register 0 | TM3CON0 | TM3CON | R/W | 8/16 | 00H |
| 0F03FH | Timer 3 control register 1 | TM3CON1 | | R/W | 8 | 00H |
| 0F090H | Capture control register | CAPCON | — | R/W | 8 | 00H |
| 0F091H | Capture status register | CAPSTAT | — | R | 8 | 00H |
| 0F092H | Capture data register 0 | CAPR0 | — | R/W | 8 | 00H |
| 0F093H | Capture data register 1 | CAPR1 | — | R/W | 8 | 00H |
| 0F094H | Capture time base data register | CAPTB | — | R | 8 | Undefined |
| 0F0A0H | PWM0 period register L | PW0PL | PW0P | R/W | 8/16 | 0FFH |
| 0F0A1H | PWM0 period register H | PW0PH | | R/W | 8 | 0FFH |
| 0F0A2H | PWM0 duty register L | PW0DL | PW0D | R/W | 8/16 | 00H |
| 0F0A3H | PWM0 duty register H | PW0DH | | R/W | 8 | 00H |
| 0F0A4H | PWM0 counter register L | PW0CL | PW0C | R/W | 8/16 | 00H |
| 0F0A5H | PWM0 counter register H | PW0CH | | R/W | 8 | 00H |
| 0F0A6H | PWM0 control register 0 | PW0CON0 | PW0CON | R/W | 8/16 | 00H |
| 0F0A7H | PWM0 control register 1 | PW0CON1 | | R/W | 8 | 40H |
| 0F0F0H | Bias circuit control register | BIASCON | — | R/W | 8 | 38H |
| 0F0F2H | Display mode register 0 | DSPMOD0 | DSPMOD | R/W | 8/16 | 00H |
| 0F0F3H | Display mode register 1 | DSPMOD1 | | R/W | 8 | 00H |
| 0F0F4H | Display control register | DSPCON | — | R/W | 8 | 00H |
| 0F100H | Display register 00 | DSPR00 | — | R/W | 8 | Undefined |
| 0F101H | Display register 01 | DSPR01 | — | R/W | 8 | Undefined |
| 0F102H | Display register 02 | DSPR02 | — | R/W | 8 | Undefined |
| 0F103H | Display register 03 | DSPR03 | — | R/W | 8 | Undefined |
| 0F104H | Display register 04 | DSPR04 | — | R/W | 8 | Undefined |
| 0F105H | Display register 05 | DSPR05 | — | R/W | 8 | Undefined |
| 0F106H | Display register 06 | DSPR06 | — | R/W | 8 | Undefined |
| 0F107H | Display register 07 | DSPR07 | — | R/W | 8 | Undefined |
| 0F108H | Display register 08 | DSPR08 | — | R/W | 8 | Undefined |
| 0F109H | Display register 09 | DSPR09 | — | R/W | 8 | Undefined |
| 0F10AH | Display register 0A | DSPR0A | — | R/W | 8 | Undefined |
| 0F10BH | Display register 0B | DSPR0B | — | R/W | 8 | Undefined |
| 0F10CH | Display register 0C | DSPR0C | — | R/W | 8 | Undefined |
| 0F10DH | Display register 0D | DSPR0D | — | R/W | 8 | Undefined |
| 0F10EH | Display register 0E | DSPR0E | — | R/W | 8 | Undefined |
| 0F10FH | Display register 0F | DSPR0F | — | R/W | 8 | Undefined |
| 0F110H | Display register 10 | DSPR10 | — | R/W | 8 | Undefined |
| 0F111H | Display register 11 | DSPR11 | — | R/W | 8 | Undefined |
| 0F112H | Display register 12 | DSPR12 | — | R/W | 8 | Undefined |
| 0F113H | Display register 13 | DSPR13 | — | R/W | 8 | Undefined |
| 0F114H | Display register 14 | DSPR14 | — | R/W | 8 | Undefined |
| 0F115H | Display register 15 | DSPR15 | — | R/W | 8 | Undefined |

| Address | Name | Symbol (Byte) | Symbol (Word) | R/W | Size | Initial value |
|---------|---|---------------|---------------|-----|------|--|
| 0F116H | Display register 16 | DSPR16 | — | R/W | 8 | Undefined |
| 0F117H | Display register 17 | DSPR17 | — | R/W | 8 | Undefined |
| 0F118H | Display register 18 | DSPR18 | — | R/W | 8 | Undefined |
| 0F119H | Display register 19 | DSPR19 | — | R/W | 8 | Undefined |
| 0F11AH | Display register 1A | DSPR1A | — | R/W | 8 | Undefined |
| 0F11BH | Display register 1B | DSPR1B | — | R/W | 8 | Undefined |
| 0F11CH | Display register 1C | DSPR1C | — | R/W | 8 | Undefined |
| 0F11DH | Display register 1D | DSPR1D | — | R/W | 8 | Undefined |
| 0F11EH | Display register 1E | DSPR1E | — | R/W | 8 | Undefined |
| 0F11FH | Display register 1F | DSPR1F | — | R/W | 8 | Undefined |
| 0F120H | Display register 20 | DSPR20 | — | R/W | 8 | Undefined |
| 0F121H | Display register 21 | DSPR21 | — | R/W | 8 | Undefined |
| 0F122H | Display register 22 | DSPR22 | — | R/W | 8 | Undefined |
| 0F123H | Display register 23 | DSPR23 | — | R/W | 8 | Undefined |
| 0F124H | Display register 24 | DSPR24 | — | R/W | 8 | Undefined |
| 0F125H | Display register 25 | DSPR25 | — | R/W | 8 | Undefined |
| 0F126H | Display register 26 | DSPR26 | — | R/W | 8 | Undefined |
| 0F127H | Display register 27 | DSPR27 | — | R/W | 8 | Undefined |
| 0F204H | Port 0 data register | P0D | — | R | 8 | Undefined |
| 0F206H | Port 0 control register 0 | P0CON0 | P0CON | R/W | 8/16 | 00H |
| 0F207H | Port 0 control register 1 | P0CON1 | | R/W | 8 | 00H |
| 0F210H | Port 2 data register | P2D | — | R/W | 8 | 00H |
| 0F212H | Port 2 control register 0 | P2CON0 | P2CON | R/W | 8/16 | 00H |
| 0F213H | Port 2 control register 1 | P2CON1 | | R/W | 8 | 00H |
| 0F214H | Port 2 mode register | P2MOD | — | R/W | 8 | 00H |
| 0F218H | Port 3 data register | P3D | — | R/W | 8 | 00H |
| 0F219H | Port 3 direction register | P3DIR | — | R/W | 8 | 00H |
| 0F21AH | Port 3 control register 0 | P3CON0 | P3CON | R/W | 8/16 | 00H |
| 0F21BH | Port 3 control register 1 | P3CON1 | | R/W | 8 | 00H |
| 0F21CH | Port 3 mode register 0 | P3MOD0 | — | R/W | 8 | 00H |
| 0F220H | Port 4 data register | P4D | — | R/W | 8 | 00H |
| 0F221H | Port 4 direction register | P4DIR | — | R/W | 8 | 00H |
| 0F222H | Port 4 control register 0 | P4CON0 | P4CON | R/W | 8/16 | 00H |
| 0F223H | Port 4 control register 1 | P4CON1 | | R/W | 8 | 00H |
| 0F224H | Port 4 mode register 0 | P4MOD0 | P4MOD | R/W | 8 | 00H |
| 0F225H | Port 4 mode register 1 | P4MOD1 | | R/W | 8 | 00H |
| 0F228H | Port 5 data register | P5D | — | R/W | 8 | FFH |
| 0F229H | Port 5 direction register | P5DIR | — | R/W | 8 | 00H |
| 0F22AH | Port 5 control register 0 | P5CON0 | P5CON | R/W | 8/16 | 00H |
| 0F22BH | Port 5 control register 1 | P5CON1 | | R/W | 8 | 00H |
| 0F22CH | Port 5 mode register 0 | P5MOD0 | P5MOD | R/W | 8 | 00H |
| 0F22DH | Port 5 mode register 1 | P5MOD1 | | R/W | 8 | 00H |
| 0F22EH | Port 5 interrupt mode register | P5ISEL | — | R/W | 8 | 00H |
| 0F230H | Port 6 data register ^{(*)1} | P6D | — | R/W | 8 | FFH ^{(*)2} 0FH ^{(*)3} |
| 0F232H | Port 6 control register 0 ^{(*)1} | P6CON0 | — | R/W | 8 | 00H |
| 0F280H | Serial port 0 transmit/receive buffer L | SIO0BUFL | SIO0BUF | R/W | 8/16 | 00H |
| 0F281H | Serial port 0 transmit/receive buffer H | SIO0BUFH | | R/W | 8 | 00H |

| Address | Name | Symbol (Byte) | Symbol (Word) | R/W | Size | Initial value |
|---------|---|------------------|------------------|-----|------|------------------|
| 0F282H | Serial port 0 control register | SIO0CON | — | R/W | 8 | 00H |
| 0F284H | Serial port 0 mode register 0 | SIO0MOD0 | SIO0MOD | R/W | 8/16 | 00H |
| 0F285H | Serial port 0 mode register 1 | SIO0MOD1 | | R/W | 8 | 00H |
| 0F288H | Serial port 1 transmit/receive buffer L | SIO1BUFL | SIO1BUF | R/W | 8/16 | 00H |
| 0F289H | Serial port 1 transmit/receive buffer H | SIO1BUFH | | R/W | 8 | 00H |
| 0F28AH | Serial port 1 control register | SIO1CON | — | R/W | 8 | 00H |
| 0F28CH | Serial port 1 mode register 0 | SIO1MOD0 | SIO1MOD | R/W | 8/16 | 00H |
| 0F28DH | Serial port 1 mode register 1 | SIO1MOD1 | | R/W | 8 | 00H |
| 0F290H | UART0 transmit/receive buffer | UA0BUF | — | R/W | 8 | 00H |
| 0F291H | UART0 control register | UA0CON | — | R/W | 8 | 00H |
| 0F292H | UART0 mode register 0 | UA0MOD0 | UA0MOD | R/W | 8/16 | 00H |
| 0F293H | UART0 mode register 1 | UA0MOD1 | | R/W | 8 | 00H |
| 0F294H | UART0 baud rate L is: | UA0BRTL | UA0BRT | R/W | 8/16 | 0FFH |
| 0F295H | UART0 baud rate register H | UA0BRTH | | R/W | 8 | 0FH |
| 0F296H | UART0 status register | UA0STAT | — | R/W | 8 | 00H |
| 0F2C0H | Melody 0 control register | MD0CON | — | R/W | 8 | 00H |
| 0F2C1H | Melody 0 tempo code register | MD0TMP | — | R/W | 8 | 00H |
| 0F2C2H | Melody 0 scale code register | MD0TON | MD0TL | R/W | 8/16 | 00H |
| 0F2C3H | Melody 0 tone length code register | MD0LEN | | R/W | 8 | 00H |
| 0F300H | RC-ADC Counter A register 0 | RADCA0 | — | R/W | 8 | 00H |
| 0F301H | RC-ADC Counter A register 1 | RADCA1 | — | R/W | 8 | 00H |
| 0F304H | RC-ADC Counter B register 0 | RADCB0 | — | R/W | 8 | 00H |
| 0F305H | RC-ADC Counter B register 1 | RADCB1 | — | R/W | 8 | 00H |
| 0F308H | RC-ADC mode register | RADMOD | — | R/W | 8 | 00H |
| 0F309H | RC-ADC control register | RADCON | — | R/W | 8 | 00H |
| 0F400H | Display allocation register A | DS0C0A | — | R/W | 8 | Undefined |
| 0F401H | Display allocation register A | DS1C0A | — | R/W | 8 | Undefined |
| 0F402H | Display allocation register A | DS2C0A | — | R/W | 8 | Undefined |
| 0F403H | Display allocation register A | DS3C0A | — | R/W | 8 | Undefined |
| 0F404H | Display allocation register A | DS4C0A | — | R/W | 8 | Undefined |
| 0F405H | Display allocation register A | DS5C0A | — | R/W | 8 | Undefined |
| 0F406H | Display allocation register A | DS6C0A | — | R/W | 8 | Undefined |
| 0F407H | Display allocation register A | DS7C0A | — | R/W | 8 | Undefined |
| 0F408H | Display allocation register A | DS8C0A | — | R/W | 8 | Undefined |
| 0F409H | Display allocation register A | DS9C0A | — | R/W | 8 | Undefined |
| 0F40AH | Display allocation register A | DS10C0A | — | R/W | 8 | Undefined |
| 0F40BH | Display allocation register A | DS11C0A | — | R/W | 8 | Undefined |
| 0F40CH | Display allocation register A | DS12C0A | — | R/W | 8 | Undefined |
| 0F40DH | Display allocation register A | DS13C0A | — | R/W | 8 | Undefined |
| 0F40EH | Display allocation register A | DS14C0A | — | R/W | 8 | Undefined |
| 0F40FH | Display allocation register A | DS15C0A | — | R/W | 8 | Undefined |
| 0F410H | Display allocation register A | DS16C0A | — | R/W | 8 | Undefined |
| 0F411H | Display allocation register A | DS17C0A | — | R/W | 8 | Undefined |
| 0F412H | Display allocation register A | DS18C0A | — | R/W | 8 | Undefined |
| 0F413H | Display allocation register A | DS19C0A | — | R/W | 8 | Undefined |
| 0F414H | Display allocation register A | DS20C0A | — | R/W | 8 | Undefined |
| 0F415H | Display allocation register A | DS21C0A | — | R/W | 8 | Undefined |
| 0F416H | Display allocation register A | DS22C0A | — | R/W | 8 | Undefined |

| Address | Name | Symbol (Byte) | Symbol (Word) | R/W | Size | Initial value |
|---------|-------------------------------|------------------|------------------|-----|------|------------------|
| 0F417H | Display allocation register A | DS23C0A | — | R/W | 8 | Undefined |
| 0F418H | Display allocation register A | DS24C0A | — | R/W | 8 | Undefined |
| 0F419H | Display allocation register A | DS25C0A | — | R/W | 8 | Undefined |
| 0F41AH | Display allocation register A | DS26C0A | — | R/W | 8 | Undefined |
| 0F41BH | Display allocation register A | DS27C0A | — | R/W | 8 | Undefined |
| 0F41CH | Display allocation register A | DS28C0A | — | R/W | 8 | Undefined |
| 0F41DH | Display allocation register A | DS29C0A | — | R/W | 8 | Undefined |
| 0F41EH | Display allocation register A | DS30C0A | — | R/W | 8 | Undefined |
| 0F41FH | Display allocation register A | DS31C0A | — | R/W | 8 | Undefined |
| 0F420H | Display allocation register A | DS32C0A | — | R/W | 8 | Undefined |
| 0F421H | Display allocation register A | DS33C0A | — | R/W | 8 | Undefined |
| 0F422H | Display allocation register A | DS34C0A | — | R/W | 8 | Undefined |
| 0F423H | Display allocation register A | DS35C0A | — | R/W | 8 | Undefined |
| 0F424H | Display allocation register A | DS36C0A | — | R/W | 8 | Undefined |
| 0F425H | Display allocation register A | DS37C0A | — | R/W | 8 | Undefined |
| 0F426H | Display allocation register A | DS38C0A | — | R/W | 8 | Undefined |
| 0F427H | Display allocation register A | DS39C0A | — | R/W | 8 | Undefined |
| 0F440H | Display allocation register A | DS0C1A | — | R/W | 8 | Undefined |
| 0F441H | Display allocation register A | DS1C1A | — | R/W | 8 | Undefined |
| 0F442H | Display allocation register A | DS2C1A | — | R/W | 8 | Undefined |
| 0F443H | Display allocation register A | DS3C1A | — | R/W | 8 | Undefined |
| 0F444H | Display allocation register A | DS4C1A | — | R/W | 8 | Undefined |
| 0F445H | Display allocation register A | DS5C1A | — | R/W | 8 | Undefined |
| 0F446H | Display allocation register A | DS6C1A | — | R/W | 8 | Undefined |
| 0F447H | Display allocation register A | DS7C1A | — | R/W | 8 | Undefined |
| 0F448H | Display allocation register A | DS8C1A | — | R/W | 8 | Undefined |
| 0F449H | Display allocation register A | DS9C1A | — | R/W | 8 | Undefined |
| 0F44AH | Display allocation register A | DS10C1A | — | R/W | 8 | Undefined |
| 0F44BH | Display allocation register A | DS11C1A | — | R/W | 8 | Undefined |
| 0F44CH | Display allocation register A | DS12C1A | — | R/W | 8 | Undefined |
| 0F44DH | Display allocation register A | DS13C1A | — | R/W | 8 | Undefined |
| 0F44EH | Display allocation register A | DS14C1A | — | R/W | 8 | Undefined |
| 0F44FH | Display allocation register A | DS15C1A | — | R/W | 8 | Undefined |
| 0F450H | Display allocation register A | DS16C1A | — | R/W | 8 | Undefined |
| 0F451H | Display allocation register A | DS17C1A | — | R/W | 8 | Undefined |
| 0F452H | Display allocation register A | DS18C1A | — | R/W | 8 | Undefined |
| 0F453H | Display allocation register A | DS19C1A | — | R/W | 8 | Undefined |
| 0F454H | Display allocation register A | DS20C1A | — | R/W | 8 | Undefined |
| 0F455H | Display allocation register A | DS21C1A | — | R/W | 8 | Undefined |
| 0F456H | Display allocation register A | DS22C1A | — | R/W | 8 | Undefined |
| 0F457H | Display allocation register A | DS23C1A | — | R/W | 8 | Undefined |
| 0F458H | Display allocation register A | DS24C1A | — | R/W | 8 | Undefined |
| 0F459H | Display allocation register A | DS25C1A | — | R/W | 8 | Undefined |
| 0F45AH | Display allocation register A | DS26C1A | — | R/W | 8 | Undefined |
| 0F45BH | Display allocation register A | DS27C1A | — | R/W | 8 | Undefined |
| 0F45CH | Display allocation register A | DS28C1A | — | R/W | 8 | Undefined |
| 0F45DH | Display allocation register A | DS29C1A | — | R/W | 8 | Undefined |

| Address | Name | Symbol (Byte) | Symbol (Word) | R/W | Size | Initial value |
|---------|-------------------------------|------------------|------------------|-----|------|------------------|
| 0F45EH | Display allocation register A | DS30C1A | — | R/W | 8 | Undefined |
| 0F45FH | Display allocation register A | DS31C1A | — | R/W | 8 | Undefined |
| 0F460H | Display allocation register A | DS32C1A | — | R/W | 8 | Undefined |
| 0F461H | Display allocation register A | DS33C1A | — | R/W | 8 | Undefined |
| 0F462H | Display allocation register A | DS34C1A | — | R/W | 8 | Undefined |
| 0F463H | Display allocation register A | DS35C1A | — | R/W | 8 | Undefined |
| 0F464H | Display allocation register A | DS36C1A | — | R/W | 8 | Undefined |
| 0F465H | Display allocation register A | DS37C1A | — | R/W | 8 | Undefined |
| 0F466H | Display allocation register A | DS38C1A | — | R/W | 8 | Undefined |
| 0F467H | Display allocation register A | DS39C1A | — | R/W | 8 | Undefined |
| 0F480H | Display allocation register A | DS0C2A | — | R/W | 8 | Undefined |
| 0F481H | Display allocation register A | DS1C2A | — | R/W | 8 | Undefined |
| 0F482H | Display allocation register A | DS2C2A | — | R/W | 8 | Undefined |
| 0F483H | Display allocation register A | DS3C2A | — | R/W | 8 | Undefined |
| 0F484H | Display allocation register A | DS4C2A | — | R/W | 8 | Undefined |
| 0F485H | Display allocation register A | DS5C2A | — | R/W | 8 | Undefined |
| 0F486H | Display allocation register A | DS6C2A | — | R/W | 8 | Undefined |
| 0F487H | Display allocation register A | DS7C2A | — | R/W | 8 | Undefined |
| 0F488H | Display allocation register A | DS8C2A | — | R/W | 8 | Undefined |
| 0F489H | Display allocation register A | DS9C2A | — | R/W | 8 | Undefined |
| 0F48AH | Display allocation register A | DS10C2A | — | R/W | 8 | Undefined |
| 0F48BH | Display allocation register A | DS11C2A | — | R/W | 8 | Undefined |
| 0F48CH | Display allocation register A | DS12C2A | — | R/W | 8 | Undefined |
| 0F48DH | Display allocation register A | DS13C2A | — | R/W | 8 | Undefined |
| 0F48EH | Display allocation register A | DS14C2A | — | R/W | 8 | Undefined |
| 0F48FH | Display allocation register A | DS15C2A | — | R/W | 8 | Undefined |
| 0F490H | Display allocation register A | DS16C2A | — | R/W | 8 | Undefined |
| 0F491H | Display allocation register A | DS17C2A | — | R/W | 8 | Undefined |
| 0F492H | Display allocation register A | DS18C2A | — | R/W | 8 | Undefined |
| 0F493H | Display allocation register A | DS19C2A | — | R/W | 8 | Undefined |
| 0F494H | Display allocation register A | DS20C2A | — | R/W | 8 | Undefined |
| 0F495H | Display allocation register A | DS21C2A | — | R/W | 8 | Undefined |
| 0F496H | Display allocation register A | DS22C2A | — | R/W | 8 | Undefined |
| 0F497H | Display allocation register A | DS23C2A | — | R/W | 8 | Undefined |
| 0F498H | Display allocation register A | DS24C2A | — | R/W | 8 | Undefined |
| 0F499H | Display allocation register A | DS25C2A | — | R/W | 8 | Undefined |
| 0F49AH | Display allocation register A | DS26C2A | — | R/W | 8 | Undefined |
| 0F49BH | Display allocation register A | DS27C2A | — | R/W | 8 | Undefined |
| 0F49CH | Display allocation register A | DS28C2A | — | R/W | 8 | Undefined |
| 0F49DH | Display allocation register A | DS29C2A | — | R/W | 8 | Undefined |
| 0F49EH | Display allocation register A | DS30C2A | — | R/W | 8 | Undefined |
| 0F49FH | Display allocation register A | DS31C2A | — | R/W | 8 | Undefined |
| 0F4A0H | Display allocation register A | DS32C2A | — | R/W | 8 | Undefined |
| 0F4A1H | Display allocation register A | DS33C2A | — | R/W | 8 | Undefined |
| 0F4A2H | Display allocation register A | DS34C2A | — | R/W | 8 | Undefined |
| 0F4A3H | Display allocation register A | DS35C2A | — | R/W | 8 | Undefined |
| 0F4A4H | Display allocation register A | DS36C2A | — | R/W | 8 | Undefined |
| 0F4A5H | Display allocation register A | DS37C2A | — | R/W | 8 | Undefined |

| Address | Name | Symbol (Byte) | Symbol (Word) | R/W | Size | Initial value |
|---------|-------------------------------|------------------|------------------|-----|------|------------------|
| 0F4A6H | Display allocation register A | DS38C2A | — | R/W | 8 | Undefined |
| 0F4A7H | Display allocation register A | DS39C2A | — | R/W | 8 | Undefined |
| 0F4C0H | Display allocation register A | DS0C3A | — | R/W | 8 | Undefined |
| 0F4C1H | Display allocation register A | DS1C3A | — | R/W | 8 | Undefined |
| 0F4C2H | Display allocation register A | DS2C3A | — | R/W | 8 | Undefined |
| 0F4C3H | Display allocation register A | DS3C3A | — | R/W | 8 | Undefined |
| 0F4C4H | Display allocation register A | DS4C3A | — | R/W | 8 | Undefined |
| 0F4C5H | Display allocation register A | DS5C3A | — | R/W | 8 | Undefined |
| 0F4C6H | Display allocation register A | DS6C3A | — | R/W | 8 | Undefined |
| 0F4C7H | Display allocation register A | DS7C3A | — | R/W | 8 | Undefined |
| 0F4C8H | Display allocation register A | DS8C3A | — | R/W | 8 | Undefined |
| 0F4C9H | Display allocation register A | DS9C3A | — | R/W | 8 | Undefined |
| 0F4CAH | Display allocation register A | DS10C3A | — | R/W | 8 | Undefined |
| 0F4CBH | Display allocation register A | DS11C3A | — | R/W | 8 | Undefined |
| 0F4CCH | Display allocation register A | DS12C3A | — | R/W | 8 | Undefined |
| 0F4CDH | Display allocation register A | DS13C3A | — | R/W | 8 | Undefined |
| 0F4CEH | Display allocation register A | DS14C3A | — | R/W | 8 | Undefined |
| 0F4CFH | Display allocation register A | DS15C3A | — | R/W | 8 | Undefined |
| 0F4D0H | Display allocation register A | DS16C3A | — | R/W | 8 | Undefined |
| 0F4D1H | Display allocation register A | DS17C3A | — | R/W | 8 | Undefined |
| 0F4D2H | Display allocation register A | DS18C3A | — | R/W | 8 | Undefined |
| 0F4D3H | Display allocation register A | DS19C3A | — | R/W | 8 | Undefined |
| 0F4D4H | Display allocation register A | DS20C3A | — | R/W | 8 | Undefined |
| 0F4D5H | Display allocation register A | DS21C3A | — | R/W | 8 | Undefined |
| 0F4D6H | Display allocation register A | DS22C3A | — | R/W | 8 | Undefined |
| 0F4D7H | Display allocation register A | DS23C3A | — | R/W | 8 | Undefined |
| 0F4D8H | Display allocation register A | DS24C3A | — | R/W | 8 | Undefined |
| 0F4D9H | Display allocation register A | DS25C3A | — | R/W | 8 | Undefined |
| 0F4DAH | Display allocation register A | DS26C3A | — | R/W | 8 | Undefined |
| 0F4DBH | Display allocation register A | DS27C3A | — | R/W | 8 | Undefined |
| 0F4DCH | Display allocation register A | DS28C3A | — | R/W | 8 | Undefined |
| 0F4DDH | Display allocation register A | DS29C3A | — | R/W | 8 | Undefined |
| 0F4DEH | Display allocation register A | DS30C3A | — | R/W | 8 | Undefined |
| 0F4DFH | Display allocation register A | DS31C3A | — | R/W | 8 | Undefined |
| 0F4E0H | Display allocation register A | DS32C3A | — | R/W | 8 | Undefined |
| 0F4E1H | Display allocation register A | DS33C3A | — | R/W | 8 | Undefined |
| 0F4E2H | Display allocation register A | DS34C3A | — | R/W | 8 | Undefined |
| 0F4E3H | Display allocation register A | DS35C3A | — | R/W | 8 | Undefined |
| 0F4E4H | Display allocation register A | DS36C3A | — | R/W | 8 | Undefined |
| 0F4E5H | Display allocation register A | DS37C3A | — | R/W | 8 | Undefined |
| 0F4E6H | Display allocation register A | DS38C3A | — | R/W | 8 | Undefined |
| 0F4E7H | Display allocation register A | DS39C3A | — | R/W | 8 | Undefined |
| 0F500H | Display allocation register A | DS0C4A | — | R/W | 8 | Undefined |
| 0F501H | Display allocation register A | DS1C4A | — | R/W | 8 | Undefined |
| 0F502H | Display allocation register A | DS2C4A | — | R/W | 8 | Undefined |
| 0F503H | Display allocation register A | DS3C4A | — | R/W | 8 | Undefined |
| 0F504H | Display allocation register A | DS4C4A | — | R/W | 8 | Undefined |
| 0F505H | Display allocation register A | DS5C4A | — | R/W | 8 | Undefined |

| Address | Name | Symbol (Byte) | Symbol (Word) | R/W | Size | Initial value |
|---------|-------------------------------|------------------|------------------|-----|------|------------------|
| 0F506H | Display allocation register A | DS6C4A | — | R/W | 8 | Undefined |
| 0F507H | Display allocation register A | DS7C4A | — | R/W | 8 | Undefined |
| 0F508H | Display allocation register A | DS8C4A | — | R/W | 8 | Undefined |
| 0F509H | Display allocation register A | DS9C4A | — | R/W | 8 | Undefined |
| 0F50AH | Display allocation register A | DS10C4A | — | R/W | 8 | Undefined |
| 0F50BH | Display allocation register A | DS11C4A | — | R/W | 8 | Undefined |
| 0F50CH | Display allocation register A | DS12C4A | — | R/W | 8 | Undefined |
| 0F50DH | Display allocation register A | DS13C4A | — | R/W | 8 | Undefined |
| 0F50EH | Display allocation register A | DS14C4A | — | R/W | 8 | Undefined |
| 0F50FH | Display allocation register A | DS15C4A | — | R/W | 8 | Undefined |
| 0F510H | Display allocation register A | DS16C4A | — | R/W | 8 | Undefined |
| 0F511H | Display allocation register A | DS17C4A | — | R/W | 8 | Undefined |
| 0F512H | Display allocation register A | DS18C4A | — | R/W | 8 | Undefined |
| 0F513H | Display allocation register A | DS19C4A | — | R/W | 8 | Undefined |
| 0F514H | Display allocation register A | DS20C4A | — | R/W | 8 | Undefined |
| 0F515H | Display allocation register A | DS21C4A | — | R/W | 8 | Undefined |
| 0F516H | Display allocation register A | DS22C4A | — | R/W | 8 | Undefined |
| 0F517H | Display allocation register A | DS23C4A | — | R/W | 8 | Undefined |
| 0F518H | Display allocation register A | DS24C4A | — | R/W | 8 | Undefined |
| 0F519H | Display allocation register A | DS25C4A | — | R/W | 8 | Undefined |
| 0F51AH | Display allocation register A | DS26C4A | — | R/W | 8 | Undefined |
| 0F51BH | Display allocation register A | DS27C4A | — | R/W | 8 | Undefined |
| 0F51CH | Display allocation register A | DS28C4A | — | R/W | 8 | Undefined |
| 0F51DH | Display allocation register A | DS29C4A | — | R/W | 8 | Undefined |
| 0F51EH | Display allocation register A | DS30C4A | — | R/W | 8 | Undefined |
| 0F51FH | Display allocation register A | DS31C4A | — | R/W | 8 | Undefined |
| 0F520H | Display allocation register A | DS32C4A | — | R/W | 8 | Undefined |
| 0F521H | Display allocation register A | DS33C4A | — | R/W | 8 | Undefined |
| 0F522H | Display allocation register A | DS34C4A | — | R/W | 8 | Undefined |
| 0F523H | Display allocation register A | DS35C4A | — | R/W | 8 | Undefined |
| 0F524H | Display allocation register A | DS36C4A | — | R/W | 8 | Undefined |
| 0F525H | Display allocation register A | DS37C4A | — | R/W | 8 | Undefined |
| 0F526H | Display allocation register A | DS38C4A | — | R/W | 8 | Undefined |
| 0F527H | Display allocation register A | DS39C4A | — | R/W | 8 | Undefined |
| 0F600H | Display allocation register B | DS0C0B | — | R/W | 8 | Undefined |
| 0F601H | Display allocation register B | DS1C0B | — | R/W | 8 | Undefined |
| 0F602H | Display allocation register B | DS2C0B | — | R/W | 8 | Undefined |
| 0F603H | Display allocation register B | DS3C0B | — | R/W | 8 | Undefined |
| 0F604H | Display allocation register B | DS4C0B | — | R/W | 8 | Undefined |
| 0F605H | Display allocation register B | DS5C0B | — | R/W | 8 | Undefined |
| 0F606H | Display allocation register B | DS6C0B | — | R/W | 8 | Undefined |
| 0F607H | Display allocation register B | DS7C0B | — | R/W | 8 | Undefined |
| 0F608H | Display allocation register B | DS8C0B | — | R/W | 8 | Undefined |
| 0F609H | Display allocation register B | DS9C0B | — | R/W | 8 | Undefined |
| 0F60AH | Display allocation register B | DS10C0B | — | R/W | 8 | Undefined |
| 0F60BH | Display allocation register B | DS11C0B | — | R/W | 8 | Undefined |
| 0F60CH | Display allocation register B | DS12C0B | — | R/W | 8 | Undefined |
| 0F60DH | Display allocation register B | DS13C0B | — | R/W | 8 | Undefined |

| Address | Name | Symbol (Byte) | Symbol (Word) | R/W | Size | Initial value |
|---------|-------------------------------|------------------|------------------|-----|------|------------------|
| 0F60EH | Display allocation register B | DS14C0B | — | R/W | 8 | Undefined |
| 0F60FH | Display allocation register B | DS15C0B | — | R/W | 8 | Undefined |
| 0F610H | Display allocation register B | DS16C0B | — | R/W | 8 | Undefined |
| 0F611H | Display allocation register B | DS17C0B | — | R/W | 8 | Undefined |
| 0F612H | Display allocation register B | DS18C0B | — | R/W | 8 | Undefined |
| 0F613H | Display allocation register B | DS19C0B | — | R/W | 8 | Undefined |
| 0F614H | Display allocation register B | DS20C0B | — | R/W | 8 | Undefined |
| 0F615H | Display allocation register B | DS21C0B | — | R/W | 8 | Undefined |
| 0F616H | Display allocation register B | DS22C0B | — | R/W | 8 | Undefined |
| 0F617H | Display allocation register B | DS23C0B | — | R/W | 8 | Undefined |
| 0F618H | Display allocation register B | DS24C0B | — | R/W | 8 | Undefined |
| 0F619H | Display allocation register B | DS25C0B | — | R/W | 8 | Undefined |
| 0F61AH | Display allocation register B | DS26C0B | — | R/W | 8 | Undefined |
| 0F61BH | Display allocation register B | DS27C0B | — | R/W | 8 | Undefined |
| 0F61CH | Display allocation register B | DS28C0B | — | R/W | 8 | Undefined |
| 0F61DH | Display allocation register B | DS29C0B | — | R/W | 8 | Undefined |
| 0F61EH | Display allocation register B | DS30C0B | — | R/W | 8 | Undefined |
| 0F61FH | Display allocation register B | DS31C0B | — | R/W | 8 | Undefined |
| 0F620H | Display allocation register B | DS32C0B | — | R/W | 8 | Undefined |
| 0F621H | Display allocation register B | DS33C0B | — | R/W | 8 | Undefined |
| 0F622H | Display allocation register B | DS34C0B | — | R/W | 8 | Undefined |
| 0F623H | Display allocation register B | DS35C0B | — | R/W | 8 | Undefined |
| 0F624H | Display allocation register B | DS36C0B | — | R/W | 8 | Undefined |
| 0F625H | Display allocation register B | DS37C0B | — | R/W | 8 | Undefined |
| 0F626H | Display allocation register B | DS38C0B | — | R/W | 8 | Undefined |
| 0F627H | Display allocation register B | DS39C0B | — | R/W | 8 | Undefined |
| 0F640H | Display allocation register B | DS0C1B | — | R/W | 8 | Undefined |
| 0F641H | Display allocation register B | DS1C1B | — | R/W | 8 | Undefined |
| 0F642H | Display allocation register B | DS2C1B | — | R/W | 8 | Undefined |
| 0F643H | Display allocation register B | DS3C1B | — | R/W | 8 | Undefined |
| 0F644H | Display allocation register B | DS4C1B | — | R/W | 8 | Undefined |
| 0F645H | Display allocation register B | DS5C1B | — | R/W | 8 | Undefined |
| 0F646H | Display allocation register B | DS6C1B | — | R/W | 8 | Undefined |
| 0F647H | Display allocation register B | DS7C1B | — | R/W | 8 | Undefined |
| 0F648H | Display allocation register B | DS8C1B | — | R/W | 8 | Undefined |
| 0F649H | Display allocation register B | DS9C1B | — | R/W | 8 | Undefined |
| 0F64AH | Display allocation register B | DS10C1B | — | R/W | 8 | Undefined |
| 0F64BH | Display allocation register B | DS11C1B | — | R/W | 8 | Undefined |
| 0F64CH | Display allocation register B | DS12C1B | — | R/W | 8 | Undefined |
| 0F64DH | Display allocation register B | DS13C1B | — | R/W | 8 | Undefined |
| 0F64EH | Display allocation register B | DS14C1B | — | R/W | 8 | Undefined |
| 0F64FH | Display allocation register B | DS15C1B | — | R/W | 8 | Undefined |
| 0F650H | Display allocation register B | DS16C1B | — | R/W | 8 | Undefined |
| 0F651H | Display allocation register B | DS17C1B | — | R/W | 8 | Undefined |
| 0F652H | Display allocation register B | DS18C1B | — | R/W | 8 | Undefined |
| 0F653H | Display allocation register B | DS19C1B | — | R/W | 8 | Undefined |
| 0F654H | Display allocation register B | DS20C1B | — | R/W | 8 | Undefined |
| 0F655H | Display allocation register B | DS21C1B | — | R/W | 8 | Undefined |

| Address | Name | Symbol (Byte) | Symbol (Word) | R/W | Size | Initial value |
|---------|-------------------------------|------------------|------------------|-----|------|------------------|
| 0F656H | Display allocation register B | DS22C1B | — | R/W | 8 | Undefined |
| 0F657H | Display allocation register B | DS23C1B | — | R/W | 8 | Undefined |
| 0F658H | Display allocation register B | DS24C1B | — | R/W | 8 | Undefined |
| 0F659H | Display allocation register B | DS25C1B | — | R/W | 8 | Undefined |
| 0F65AH | Display allocation register B | DS26C1B | — | R/W | 8 | Undefined |
| 0F65BH | Display allocation register B | DS27C1B | — | R/W | 8 | Undefined |
| 0F65CH | Display allocation register B | DS28C1B | — | R/W | 8 | Undefined |
| 0F65DH | Display allocation register B | DS29C1B | — | R/W | 8 | Undefined |
| 0F65EH | Display allocation register B | DS30C1B | — | R/W | 8 | Undefined |
| 0F65FH | Display allocation register B | DS31C1B | — | R/W | 8 | Undefined |
| 0F660H | Display allocation register B | DS32C1B | — | R/W | 8 | Undefined |
| 0F661H | Display allocation register B | DS33C1B | — | R/W | 8 | Undefined |
| 0F662H | Display allocation register B | DS34C1B | — | R/W | 8 | Undefined |
| 0F663H | Display allocation register B | DS35C1B | — | R/W | 8 | Undefined |
| 0F664H | Display allocation register B | DS36C1B | — | R/W | 8 | Undefined |
| 0F665H | Display allocation register B | DS37C1B | — | R/W | 8 | Undefined |
| 0F666H | Display allocation register B | DS38C1B | — | R/W | 8 | Undefined |
| 0F667H | Display allocation register B | DS39C1B | — | R/W | 8 | Undefined |
| 0F680H | Display allocation register B | DS0C2B | — | R/W | 8 | Undefined |
| 0F681H | Display allocation register B | DS1C2B | — | R/W | 8 | Undefined |
| 0F682H | Display allocation register B | DS2C2B | — | R/W | 8 | Undefined |
| 0F683H | Display allocation register B | DS3C2B | — | R/W | 8 | Undefined |
| 0F684H | Display allocation register B | DS4C2B | — | R/W | 8 | Undefined |
| 0F685H | Display allocation register B | DS5C2B | — | R/W | 8 | Undefined |
| 0F686H | Display allocation register B | DS6C2B | — | R/W | 8 | Undefined |
| 0F687H | Display allocation register B | DS7C2B | — | R/W | 8 | Undefined |
| 0F688H | Display allocation register B | DS8C2B | — | R/W | 8 | Undefined |
| 0F689H | Display allocation register B | DS9C2B | — | R/W | 8 | Undefined |
| 0F68AH | Display allocation register B | DS10C2B | — | R/W | 8 | Undefined |
| 0F68BH | Display allocation register B | DS11C2B | — | R/W | 8 | Undefined |
| 0F68CH | Display allocation register B | DS12C2B | — | R/W | 8 | Undefined |
| 0F68DH | Display allocation register B | DS13C2B | — | R/W | 8 | Undefined |
| 0F68EH | Display allocation register B | DS14C2B | — | R/W | 8 | Undefined |
| 0F68FH | Display allocation register B | DS15C2B | — | R/W | 8 | Undefined |
| 0F690H | Display allocation register B | DS16C2B | — | R/W | 8 | Undefined |
| 0F691H | Display allocation register B | DS17C2B | — | R/W | 8 | Undefined |
| 0F692H | Display allocation register B | DS18C2B | — | R/W | 8 | Undefined |
| 0F693H | Display allocation register B | DS19C2B | — | R/W | 8 | Undefined |
| 0F694H | Display allocation register B | DS20C2B | — | R/W | 8 | Undefined |
| 0F695H | Display allocation register B | DS21C2B | — | R/W | 8 | Undefined |
| 0F696H | Display allocation register B | DS22C2B | — | R/W | 8 | Undefined |
| 0F697H | Display allocation register B | DS23C2B | — | R/W | 8 | Undefined |
| 0F698H | Display allocation register B | DS24C2B | — | R/W | 8 | Undefined |
| 0F699H | Display allocation register B | DS25C2B | — | R/W | 8 | Undefined |
| 0F69AH | Display allocation register B | DS26C2B | — | R/W | 8 | Undefined |
| 0F69BH | Display allocation register B | DS27C2B | — | R/W | 8 | Undefined |
| 0F69CH | Display allocation register B | DS28C2B | — | R/W | 8 | Undefined |
| 0F69DH | Display allocation register B | DS29C2B | — | R/W | 8 | Undefined |

| Address | Name | Symbol (Byte) | Symbol (Word) | R/W | Size | Initial value |
|---------|-------------------------------|------------------|------------------|-----|------|------------------|
| 0F69EH | Display allocation register B | DS30C2B | — | R/W | 8 | Undefined |
| 0F69FH | Display allocation register B | DS31C2B | — | R/W | 8 | Undefined |
| 0F6A0H | Display allocation register B | DS32C2B | — | R/W | 8 | Undefined |
| 0F6A1H | Display allocation register B | DS33C2B | — | R/W | 8 | Undefined |
| 0F6A2H | Display allocation register B | DS34C2B | — | R/W | 8 | Undefined |
| 0F6A3H | Display allocation register B | DS35C2B | — | R/W | 8 | Undefined |
| 0F6A4H | Display allocation register B | DS36C2B | — | R/W | 8 | Undefined |
| 0F6A5H | Display allocation register B | DS37C2B | — | R/W | 8 | Undefined |
| 0F6A6H | Display allocation register B | DS38C2B | — | R/W | 8 | Undefined |
| 0F6A7H | Display allocation register B | DS39C2B | — | R/W | 8 | Undefined |
| 0F6C0H | Display allocation register B | DS0C3B | — | R/W | 8 | Undefined |
| 0F6C1H | Display allocation register B | DS1C3B | — | R/W | 8 | Undefined |
| 0F6C2H | Display allocation register B | DS2C3B | — | R/W | 8 | Undefined |
| 0F6C3H | Display allocation register B | DS3C3B | — | R/W | 8 | Undefined |
| 0F6C4H | Display allocation register B | DS4C3B | — | R/W | 8 | Undefined |
| 0F6C5H | Display allocation register B | DS5C3B | — | R/W | 8 | Undefined |
| 0F6C6H | Display allocation register B | DS6C3B | — | R/W | 8 | Undefined |
| 0F6C7H | Display allocation register B | DS7C3B | — | R/W | 8 | Undefined |
| 0F6C8H | Display allocation register B | DS8C3B | — | R/W | 8 | Undefined |
| 0F6C9H | Display allocation register B | DS9C3B | — | R/W | 8 | Undefined |
| 0F6CAH | Display allocation register B | DS10C3B | — | R/W | 8 | Undefined |
| 0F6CBH | Display allocation register B | DS11C3B | — | R/W | 8 | Undefined |
| 0F6CCH | Display allocation register B | DS12C3B | — | R/W | 8 | Undefined |
| 0F6CDH | Display allocation register B | DS13C3B | — | R/W | 8 | Undefined |
| 0F6CEH | Display allocation register B | DS14C3B | — | R/W | 8 | Undefined |
| 0F6CFH | Display allocation register B | DS15C3B | — | R/W | 8 | Undefined |
| 0F6D0H | Display allocation register B | DS16C3B | — | R/W | 8 | Undefined |
| 0F6D1H | Display allocation register B | DS17C3B | — | R/W | 8 | Undefined |
| 0F6D2H | Display allocation register B | DS18C3B | — | R/W | 8 | Undefined |
| 0F6D3H | Display allocation register B | DS19C3B | — | R/W | 8 | Undefined |
| 0F6D4H | Display allocation register B | DS20C3B | — | R/W | 8 | Undefined |
| 0F6D5H | Display allocation register B | DS21C3B | — | R/W | 8 | Undefined |
| 0F6D6H | Display allocation register B | DS22C3B | — | R/W | 8 | Undefined |
| 0F6D7H | Display allocation register B | DS23C3B | — | R/W | 8 | Undefined |
| 0F6D8H | Display allocation register B | DS24C3B | — | R/W | 8 | Undefined |
| 0F6D9H | Display allocation register B | DS25C3B | — | R/W | 8 | Undefined |
| 0F6DAH | Display allocation register B | DS26C3B | — | R/W | 8 | Undefined |
| 0F6DBH | Display allocation register B | DS27C3B | — | R/W | 8 | Undefined |
| 0F6DCH | Display allocation register B | DS28C3B | — | R/W | 8 | Undefined |
| 0F6DDH | Display allocation register B | DS29C3B | — | R/W | 8 | Undefined |
| 0F6DEH | Display allocation register B | DS30C3B | — | R/W | 8 | Undefined |
| 0F6DFH | Display allocation register B | DS31C3B | — | R/W | 8 | Undefined |
| 0F6E0H | Display allocation register B | DS32C3B | — | R/W | 8 | Undefined |
| 0F6E1H | Display allocation register B | DS33C3B | — | R/W | 8 | Undefined |
| 0F6E2H | Display allocation register B | DS34C3B | — | R/W | 8 | Undefined |
| 0F6E3H | Display allocation register B | DS35C3B | — | R/W | 8 | Undefined |
| 0F6E4H | Display allocation register B | DS36C3B | — | R/W | 8 | Undefined |
| 0F6E5H | Display allocation register B | DS37C3B | — | R/W | 8 | Undefined |

| Address | Name | Symbol (Byte) | Symbol (Word) | R/W | Size | Initial value |
|---------|-------------------------------|------------------|------------------|-----|------|------------------|
| 0F6E6H | Display allocation register B | DS38C3B | — | R/W | 8 | Undefined |
| 0F6E7H | Display allocation register B | DS39C3B | — | R/W | 8 | Undefined |
| 0F700H | Display allocation register B | DS0C4B | — | R/W | 8 | Undefined |
| 0F701H | Display allocation register B | DS1C4B | — | R/W | 8 | Undefined |
| 0F702H | Display allocation register B | DS2C4B | — | R/W | 8 | Undefined |
| 0F703H | Display allocation register B | DS3C4B | — | R/W | 8 | Undefined |
| 0F704H | Display allocation register B | DS4C4B | — | R/W | 8 | Undefined |
| 0F705H | Display allocation register B | DS5C4B | — | R/W | 8 | Undefined |
| 0F706H | Display allocation register B | DS6C4B | — | R/W | 8 | Undefined |
| 0F707H | Display allocation register B | DS7C4B | — | R/W | 8 | Undefined |
| 0F708H | Display allocation register B | DS8C4B | — | R/W | 8 | Undefined |
| 0F709H | Display allocation register B | DS9C4B | — | R/W | 8 | Undefined |
| 0F70AH | Display allocation register B | DS10C4B | — | R/W | 8 | Undefined |
| 0F70BH | Display allocation register B | DS11C4B | — | R/W | 8 | Undefined |
| 0F70CH | Display allocation register B | DS12C4B | — | R/W | 8 | Undefined |
| 0F70DH | Display allocation register B | DS13C4B | — | R/W | 8 | Undefined |
| 0F70EH | Display allocation register B | DS14C4B | — | R/W | 8 | Undefined |
| 0F70FH | Display allocation register B | DS15C4B | — | R/W | 8 | Undefined |
| 0F710H | Display allocation register B | DS16C4B | — | R/W | 8 | Undefined |
| 0F711H | Display allocation register B | DS17C4B | — | R/W | 8 | Undefined |
| 0F712H | Display allocation register B | DS18C4B | — | R/W | 8 | Undefined |
| 0F713H | Display allocation register B | DS19C4B | — | R/W | 8 | Undefined |
| 0F714H | Display allocation register B | DS20C4B | — | R/W | 8 | Undefined |
| 0F715H | Display allocation register B | DS21C4B | — | R/W | 8 | Undefined |
| 0F716H | Display allocation register B | DS22C4B | — | R/W | 8 | Undefined |
| 0F717H | Display allocation register B | DS23C4B | — | R/W | 8 | Undefined |
| 0F718H | Display allocation register B | DS24C4B | — | R/W | 8 | Undefined |
| 0F719H | Display allocation register B | DS25C4B | — | R/W | 8 | Undefined |
| 0F71AH | Display allocation register B | DS26C4B | — | R/W | 8 | Undefined |
| 0F71BH | Display allocation register B | DS27C4B | — | R/W | 8 | Undefined |
| 0F71CH | Display allocation register B | DS28C4B | — | R/W | 8 | Undefined |
| 0F71DH | Display allocation register B | DS29C4B | — | R/W | 8 | Undefined |
| 0F71EH | Display allocation register B | DS30C4B | — | R/W | 8 | Undefined |
| 0F71FH | Display allocation register B | DS31C4B | — | R/W | 8 | Undefined |
| 0F720H | Display allocation register B | DS32C4B | — | R/W | 8 | Undefined |
| 0F721H | Display allocation register B | DS33C4B | — | R/W | 8 | Undefined |
| 0F722H | Display allocation register B | DS34C4B | — | R/W | 8 | Undefined |
| 0F723H | Display allocation register B | DS35C4B | — | R/W | 8 | Undefined |
| 0F724H | Display allocation register B | DS36C4B | — | R/W | 8 | Undefined |
| 0F725H | Display allocation register B | DS37C4B | — | R/W | 8 | Undefined |
| 0F726H | Display allocation register B | DS38C4B | — | R/W | 8 | Undefined |
| 0F727H | Display allocation register B | DS39C4B | — | R/W | 8 | Undefined |

(*1) ML610407 and ML610408 have this register, but ML610409 does not have it.

(*2) Initial value for ML610407

(*3) Initial value for ML610408

Appendix B Package Dimensions

(Unit: mm)

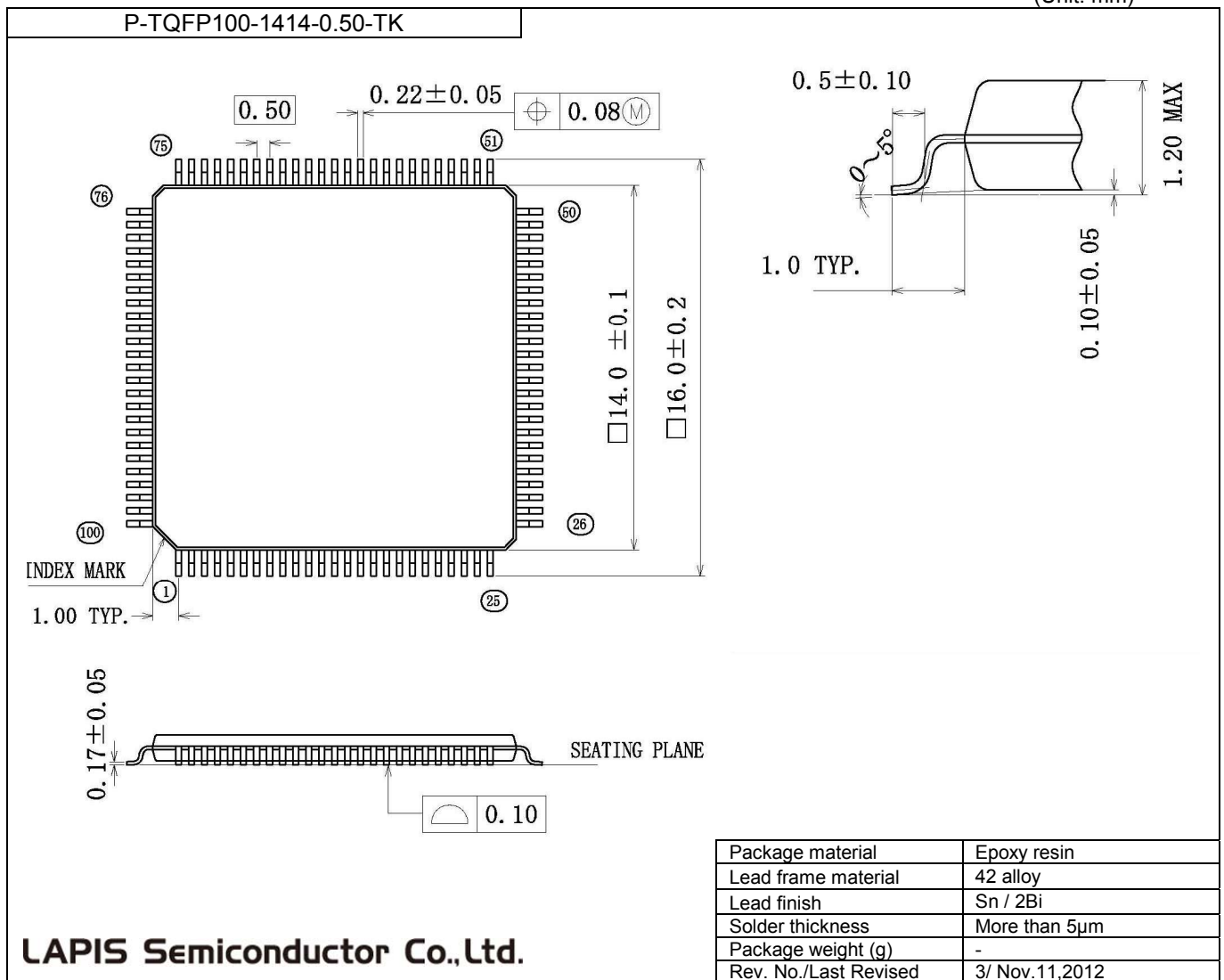

Notes for Mounting the Surface Mount Type Package

The surface mount type packages are very susceptible to heat in reflow mounting and humidity absorbed in storage.

Therefore, before you perform reflow mounting, contact ROHM's responsible sales person for the product name, package name, pin number, package code and desired mounting conditions (reflow method, temperature and times).

Appendix C Electrical Characteristics

● Absolute Maximum Ratings

(V_{SS}= 0V)

| Parameter | Symbol | Condition | Rating | Unit |
|------------------------|-------------------|----------------------|------------------------------|------|
| Power supply voltage 1 | V _{DD} | Ta=25°C | -0.3 to +4.6 | V |
| Power supply voltage 2 | V _{DDL} | Ta=25°C | -0.3 to +3.6 | V |
| Power supply voltage 3 | V _{L1} | Ta=25°C | -0.3 to +2.0 | V |
| Power supply voltage 4 | V _{L2} | Ta=25°C | -0.3 to +4.0 | V |
| Power supply voltage 5 | V _{L3} | Ta=25°C | -0.3 to +6.0 | V |
| Input voltage | V _{IN} | Ta=25°C | -0.3 to V _{DD} +0.3 | V |
| Output voltage | V _{OUT} | Ta=25°C | -0.3 to V _{DD} +0.3 | V |
| output current 1 | I _{OUT1} | Port 3 to 6, Ta=25°C | -12 to +11 | mA |
| Output current 2 | I _{OUT2} | Port 2, Ta=25°C | -12 to +20 | mA |
| Power dissipation | PD | Ta=25°C | 0.9 | W |
| Storage temperature | T _{STG} | — | -55 to +150 | °C |

● Recommended Operation Condition

(V_{SS}= 0V)

| Parameter | Symbol | Condition | Range | Unit |
|--|--------------------|--------------------------------|-----------------------------------|------|
| Operating temperature | T _{OP} | without P version | -20 to +70 | °C |
| | | P version | -40 to +85 | |
| Operating voltage | V _{DD} | f _{OP} =30k to 625kHz | 1.25 to 3.6 | V |
| | | f _{OP} =30k to 2.5MHz | 1.8 to 3.6 | |
| Operating frequency (CPU) | f _{OP} | V _{DD} =1.25 to 3.6V | 30k to 625k | Hz |
| | | V _{DD} =1.8 to 3.6V | 30k to 2.5M | |
| Low-speed crystal oscillation frequency | f _{XTL} | — | 32.768k | Hz |
| Low-speed crystal oscillation external capacitance | C _{DL} | — | 3 to 18 | pF |
| | C _{GL} | — | 3 to 18 | |
| V _{DD} pin external capacitance | C _V | — | 1.0±30% to 2.2±30%* ¹ | |
| V _{DDL} pin external capacitance | C _L | — | 0.47±30% to 2.2±30%* ² | μF |
| V _{L1, 2, or 3} pin external capacitance | C _{a,b,c} | — | 0.1±30% | μF |
| Pin-to-pin (C1 to C2) external capacitance | C ₁₂ | — | 0.47±30% | μF |

*¹: Please select as C_V is larger than C_L or same as C_L.

*²: When the load of V_{DD} is small and the power rise time is too short, it may happen that the power-on reset is not generated. In this case please select C_L with larger capacitance

● Operating Conditions of Flash Memory

(V_{SS}= 0V)

| Parameter | Symbol | Condition | Range | Unit |
|-----------------------|------------------|-----------------------------|-------------|--------|
| Operating temperature | T _{OP} | At write/erase | 0 to +40 | °C |
| Operating voltage | V _{DD} | At write/erase | 2.75 to 3.6 | V |
| | V _{DDL} | At write/erase [†] | 2.5 to 2.75 | |
| | V _{PP} | At write/erase | 7.7 to 8.3 | |
| Rewrite count | C _{EP} | — | 80 | cycles |
| Data retention | Y _{DR} | — | 10 | years |

[†]: When writing to and erasing on the flash Memory, the voltage in the specified range needs to be supplied to the V_{DDL} pin.
The V_{PP} pin has an internal pull-down resistor.

● DC Characteristics (1/5)

(V_{DD}=1.25 to 3.6V, V_{SS}=0V, T_a=-20 to +70°C, T_a=-40 to +85°C for P version, unless otherwise specified)

| Parameter | Symbol | Condition | Rating | | | Unit | Measur ement circuit |
|---|-------------------|----------------------------------|----------------------|--------------|------|--------------|----------------------------|
| | | | Min. | Typ. | Max. | | |
| 500kHz/2MHz RC oscillation frequency | f _{RC} | V _{DD} =1.25 to 3.6V | T _a =25°C | Typ. -10% | 500 | Typ. +10% | kHz |
| | | | *3 | Typ. -25% | 500 | Typ. +25% | |
| | | V _{DD} =1.8 to 3.6V | T _a =25°C | Typ. -10% | 2.0 | Typ. +10% | MHz |
| | | | *3 | Typ. -25% | 2.0 | Typ. +25% | |
| Low-speed crystal oscillation start time*2 | T _{XTL} | — | — | 0.6 | 2 | s | 1 |
| 500kHz/2MHz RC oscillation start time | T _{RC} | — | — | — | 3 | μs | |
| Low-speed oscillation stop detect time*1 | T _{STOP} | — | 12 | 16.4 | 41 | ms | |
| Reset pulse width | P _{RST} | — | 200 | — | — | μs | |
| Reset noise elimination pulse width | P _{NRST} | — | — | — | 0.3 | | |
| Power-on reset generated power rise time | T _{POR} | — | — | — | 10 | ms | |

*1: When low-speed crystal oscillation stops for a duration more than the low-speed oscillation stop detect time, the system is reset to shift to system reset mode.

*2: 32.768kHz crystal resonator DT-26 (Load capacitance 6pF) (made by KDS:DAISHINKU CORP.) is used (C_{GL}=C_{DL}=6pF).

*3: Recommended operating temperature (T_a=-20 to 70°C, T_a=-40 to 85°C for P version)

● Reset

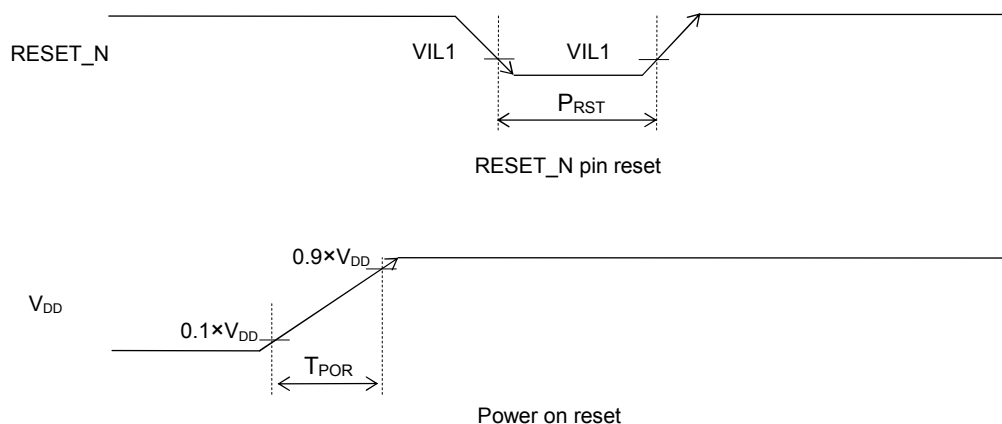

●DC Characteristics (2/5)

($V_{DD}=1.25$ to $3.6V$, $V_{SS}=0V$, $T_a=-20$ to $+70^{\circ}C$, $T_a=-40$ to $+85^{\circ}C$ for P version, unless otherwise specified)

| Parameter | Symbol | Condition | Rating | | | Unit | Measur ement circuit |
|---|------------------|-----------------------|--------|------|------|-------|----------------------------|
| | | | Min. | Typ. | Max. | | |
| V _{DDL} voltage | V _{DDL} | fop=30k to 625kHz | 1.1 | 1.2 | 1.3 | V | 1 |
| | | fop=30k to 2.5MHz | 1.35 | 1.5 | 1.65 | | |
| V _{DDL} temperature deviation *1 | ΔV_{DDL} | V _{DD} =3.0V | — | -1 | — | mV/°C | |
| V _{DDL} voltage dependency *1 | ΔV_{DDL} | — | — | 5 | 20 | mV/V | |

*1: The maximum V_{DDL} voltage becomes the V_{DD} voltage level when the V_{DDL} voltage determined by the temperature and voltage deviations mathematically exceeds the V_{DD} voltage.

●DC Characteristics (3/5)

(V_{DD}=3.0V, V_{SS}=0V, Ta=-20 to +70°C, Ta=-40 to +85°C for P version, unless otherwise specified)

| Parameter | Symbol | Condition | Rating | | | Unit | Measur ement circuit | |
|-----------------------|--------|--|---------|------|------|------|----------------------------|---|
| | | | Min. | Typ. | Max. | | | |
| Supply current 1 | IDD1 | CPU: In STOP state. Low-speed/High-speed oscillation: stopped. | Ta=25°C | — | 0.4 | 0.8 | μA | 1 |
| | | | *5 | — | — | 6.5 | | |
| Supply current 2 | IDD2 | CPU: In HALT state. (LTBC, WDT: Operating)*3*4. High-speed 500kHz/2MHz oscillation: Stopped. LCD/BIAS circuits: Operating *6 | Ta=25°C | — | 0.9 | 1.8 | μA | |
| | | | *5 | — | — | 7.5 | | |
| Supply current 3 | IDD3 | CPU: In 32.768kHz operating state.*1*3 High-speed 500kHz/2MHz oscillation: Stopped, LCD/BIAS circuits: Operating *2 | Ta=25°C | — | 4.0 | 7.5 | μA | |
| | | | *5 | — | — | 11.0 | | |
| Supply current 4-1 | IDD4-1 | CPU: In 500kHz RC operating state. LCD/BIAS circuits: Operating.*2 | Ta=25°C | — | 60 | 80 | μA | |
| | | | *5 | — | — | 90 | | |
| Supply current 4-2 | IDD4-2 | CPU: In 2MHz RC operating state. LCD/BIAS circuits: Operating.*2 | Ta=25°C | — | 240 | 300 | μA | |
| | | | *5 | — | — | 320 | | |

*1: When the CPU operating rate is 100% (no HALT state).

*2: All SEGs: off waveform, No LCD panel load, 1/3 bias, 1/3 duty, Frame frequency: Approx. 64 Hz, Bias voltage multiplying clock: 1/128 LSCLK (256Hz)

*3: 32.768KHz crystal resonator DT-26 (Load capacitance 6pF) (made by KDS:DAISHINKU CORP.) is used (C_{GL}=C_{DL}=6pF)

*4: Significant bits of BLKCON0 to BLKCON4 registers are all "1" except DLCD bit on BLKCON4.

*5: Recommended operating temperature (Ta=-20 to 70°C, Ta=-40 to 85°C for P version)

*6: LCD stop mode, 1/3 bias, Bias voltage multiplying clock: 1/128 LSCLK (256Hz)

●DC Characteristics (4/5)

($V_{DD}=1.25$ to $3.6V$, $V_{SS}=0V$, $T_a=-20$ to $+70^{\circ}C$, $T_a=-40$ to $+85^{\circ}C$ for P version, unless otherwise specified)

| Parameter | Symbol | Condition | Rating | | | Unit | Measur ement circuit |
|--|--------|--|------------------|------|------------------|---------|----------------------------|
| | | | Min. | Typ. | Max. | | |
| Output voltage 1 (P20 to P22, P24 (N-channel open drain output mode is not selected)) (P30 to P35) (P40 to P47) (P50 to P57) (P60 to P63) ^{*2} (P60 to P67) ^{*1} | VOH1 | IOH1=-0.5mA, $V_{DD}=1.8$ to $3.6V$ | V_{DD} -0.5 | — | — | V | 2 |
| | | IOH1=-0.03mA, $V_{DD}=1.25$ to $3.6V$ | V_{DD} -0.3 | — | — | | |
| | VOL1 | IOL1=+0.5mA, $V_{DD}=1.8$ to $3.6V$ | — | — | 0.5 | | |
| | | IOL1=+0.1mA, $V_{DD}=1.25$ to $3.6V$ | — | — | 0.3 | | |
| Output voltage 2 (P20 to P22, P24 (N-channel open drain output mode is selected)) | VOL2 | IOL2=+5mA, $V_{DD}=1.8$ to $3.6V$ | — | — | 0.5 | V | 2 |
| Output voltage 3 (COM0 to 4) (SEG0 to 31) ^{*1} (SEG0 to 35) ^{*2} (SEG0 to 39) ^{*3} | VOH3 | IOH3=-0.05mA, $V_{L1}=1.2V$ | V_{L3} -0.2 | — | — | | |
| | VOML3 | IOML3=+0.05mA, $V_{L1}=1.2V$ | — | — | V_{L2} +0.2 | | |
| | VOML3S | IOML3S=-0.05mA, $V_{L1}=1.2V$ | V_{L2} -0.2 | — | — | | |
| | VOLM3 | IOLM3=+0.05mA, $V_{L1}=1.2V$ | — | — | V_{L1} +0.2 | | |
| | VOLM3S | IOLM3S=-0.05mA, $V_{L1}=1.2V$ | V_{L1} -0.2 | — | — | | |
| | VOL3 | IOL3=+0.05mA, $V_{L1}=1.2V$ | — | — | 0.2 | | |
| Output leakage (P20 to P22,P24) (P30 to P35) (P40 to P47) (P50 to P57) (P60 to P63) ^{*2} (P60 to P67) ^{*1} | IOOH | VOH= V_{DD} (in high-impedance state) | — | — | 1 | μA | 3 |
| | IOOL | VOL= V_{SS} (in high-impedance state) | -1 | — | — | | |
| Input current 1 (RESET_N) (TEST1_N) | IIH1 | VIH1= V_{DD} | — | — | 1 | μA | 4 |
| | IIL1 | VIL1= V_{SS} | -600 | -300 | -2 | | |
| Input current 2 (TEST0) | IIH2 | VIH2= V_{DD} | 2 | 300 | 600 | | |
| | IIL2 | VIL2= V_{SS} | -1 | — | — | | |
| Input current 3 (P00 to P04) (P30 to P35) (P40 to P47) (P50 to P57) | IIH3 | VIH3= V_{DD} , $V_{DD}=1.8$ to $3.6V$ (when pulled-down) | 2 | 30 | 200 | | |
| | | VIH3= V_{DD} , $V_{DD}=1.25$ to $3.6V$ (when pulled-down) | 0.01 | 30 | 200 | | |
| | IIL3 | VIL3= V_{SS} , $V_{DD}=1.8$ to $3.6V$ (when pulled-up) | -200 | -30 | -2 | | |
| | | VIL3= V_{SS} , $V_{DD}=1.25$ to $3.6V$ (when pulled-up) | -200 | -30 | -0.01 | | |
| | IIH3Z | VIH3= V_{DD} (in high-impedance state) | — | — | 1 | | |
| | IIL3Z | VIL3= V_{SS} (in high-impedance state) | -1 | — | — | | |

*1: Characteristics for ML610407.

*2: Characteristics for ML610408.

*3: Characteristics for ML610409.

●DC Characteristics (5/5)

(V_{DD}=1.25 to 3.6V, V_{SS}=0V, Ta=-20 to +70°C, Ta=-40 to +85°C for P version, unless otherwise specified)

| Parameter | Symbol | Condition | Rating | | | Unit | Measur ement circuit |
|---|--------|--|-------------------------|------|-------------------------|------|----------------------------|
| | | | Min. | Typ. | Max. | | |
| Input voltage 1 (RESET_N) (TEST0, TEST1_N) (P00 to P04) (P30 to P35) (P40 to P47) (P50 to P57) | VIH1 | — | 0.7 ×V _{DD} | — | V _{DD} | V | 5 |
| | VIL1 | V _{DD} =1.8 to 3.6V | 0 | — | 0.3 ×V _{DD} | | |
| | | V _{DD} =1.25 to 3.6V | 0 | — | 0.2 ×V _{DD} | | |
| Input pin capacitance (P00 to P04) (P30 to P35) (P40 to P47) (P50 to P57) | CIN | f=10kHz V _{rms} =50mV Ta=25°C | — | — | 5 | pF | — |

● Measuring circuit

Measuring circuit 1

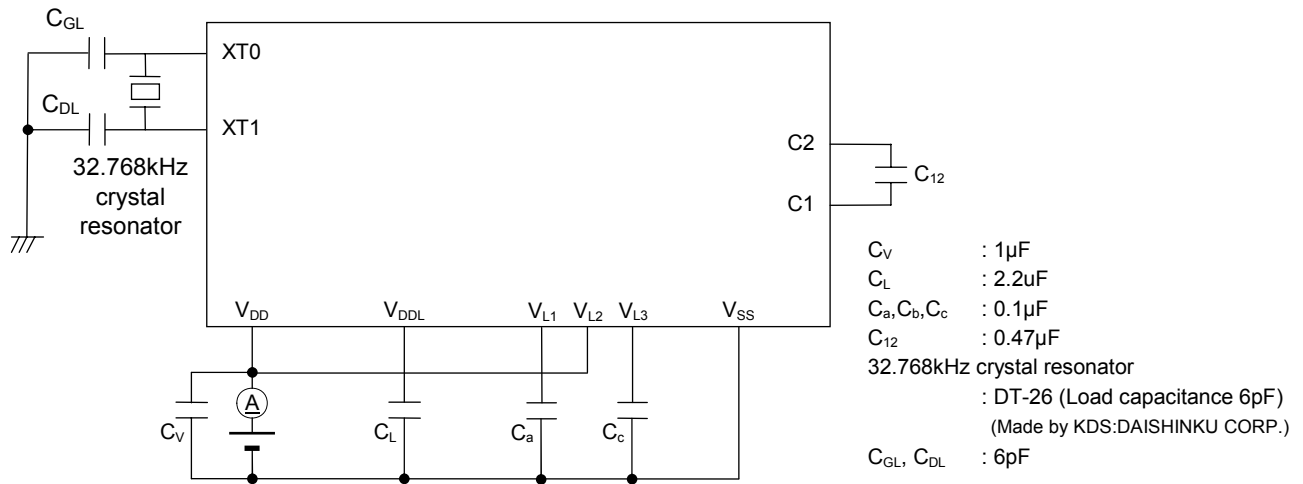

Measuring circuit 2

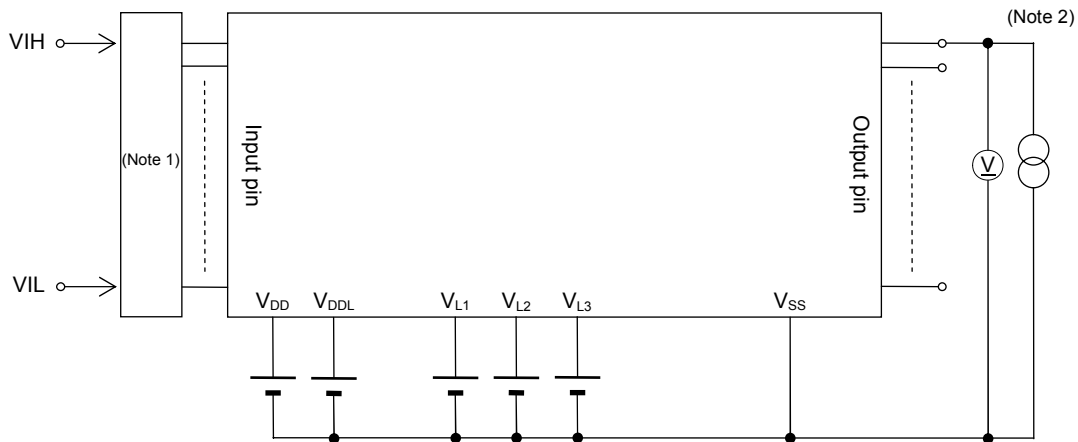

(Note 1) Input logic circuit to determine the specified measuring conditions.

(Note 2) Repeats for the specified output pin

Measuring circuit 3

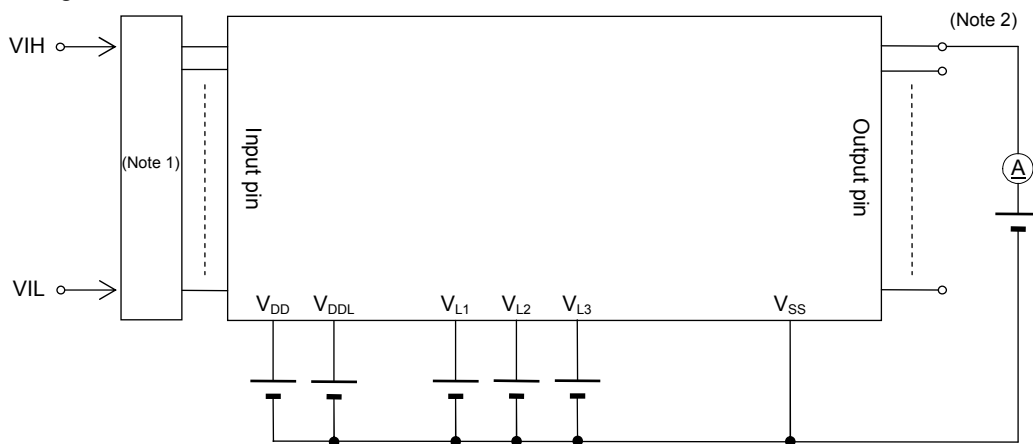

(Note 1) Input logic circuit to determine the specified measuring conditions.
 (Note 2) Repeats for the specified output pin

Measuring circuit 4

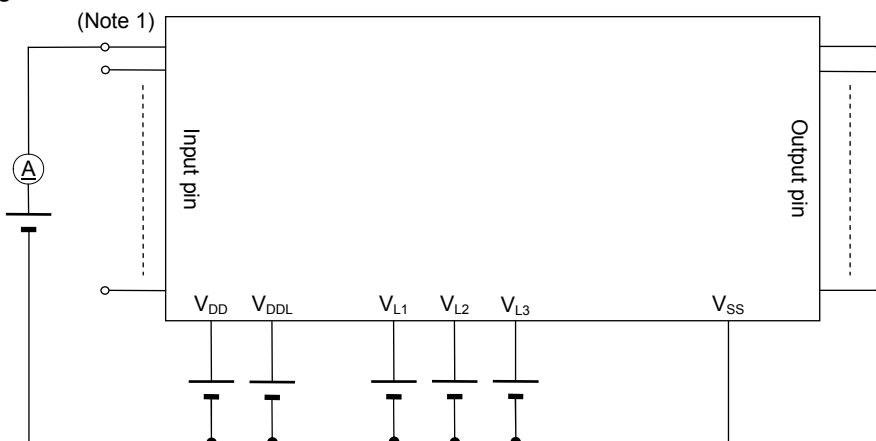

(Note 1) Repeats for the specified input pin

Measuring circuit 5

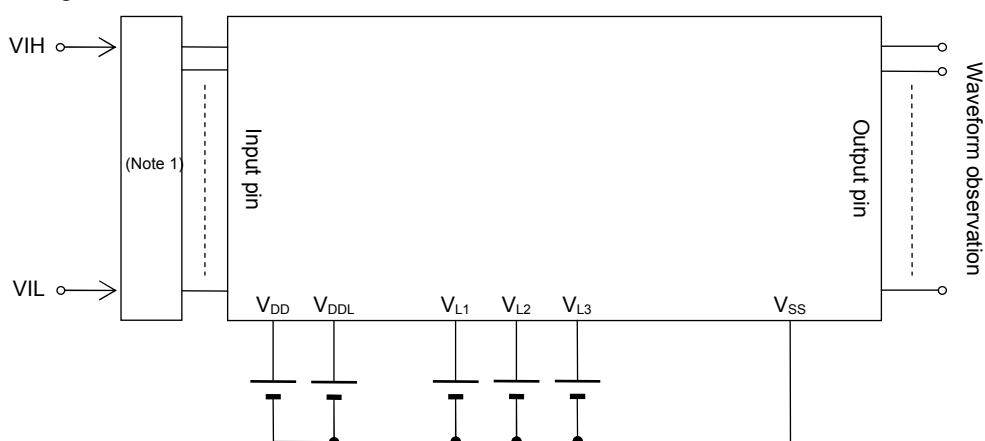

(Note 1) Input logic circuit to determine the specified measuring conditions.

● AC Characteristics (External Interrupt)

($V_{DD}=1.25$ to $3.6V$, $V_{SS}=0V$, $T_a=-20$ to $+70^{\circ}C$, $T_a=-40$ to $+85^{\circ}C$ for P version, unless otherwise specified)

| Parameter | Symbol | Condition | Rating | | | Unit |
|-----------------------------------|-----------|--|--------|------|-------|---------|
| | | | Min. | Typ. | Max. | |
| External interrupt disable period | t_{NUL} | Interrupt: Enabled (MIE = 1), CPU: NOP operation System clock: 32.768kHz | 76.8 | — | 106.8 | μs |

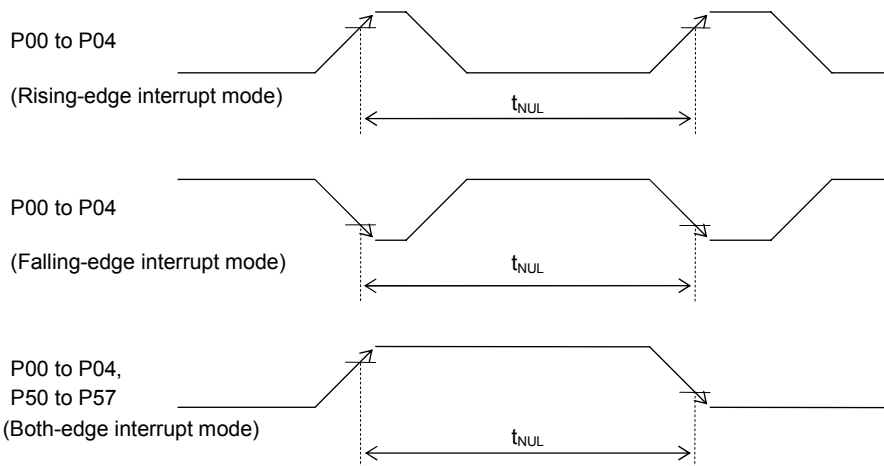

● AC Characteristics (UART)

($V_{DD}=1.25$ to $3.6V$, $V_{SS}=0V$, $T_a=-20$ to $+70^{\circ}C$, $T_a=-40$ to $+85^{\circ}C$ for P version, unless otherwise specified)

| Parameter | Symbol | Condition | Rating | | | Unit |
|--------------------|------------|-----------|-------------------|------------|-------------------|------|
| | | | Min. | Typ. | Max. | |
| Transmit baud rate | t_{TBRT} | — | — | BRT^{*1} | — | s |
| Receive baud rate | t_{RBRT} | — | BRT^{*1} -3% | BRT^{*1} | BRT^{*1} +3% | s |

*1: Baud rate period (including the error of the clock frequency selected) set with the UART baud rate register (UA0BRTL,H) and the UART mode register 0 (UA0MOD0).

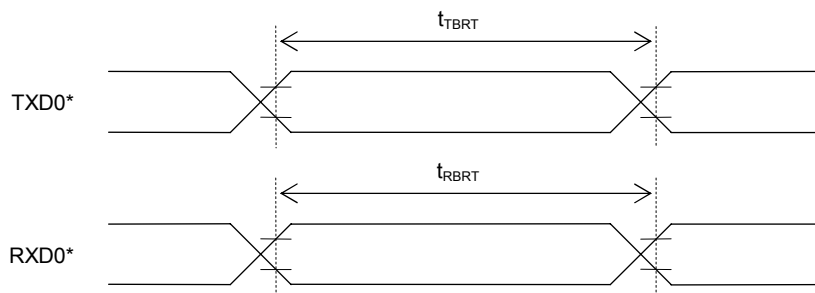

*: Indicates the secondary function of the port.

● AC Characteristics (Synchronous Serial Port)

($V_{DD}=1.25$ to $3.6V$, $V_{SS}=0V$, $T_a=-20$ to $+70^{\circ}C$, $T_a=-40$ to $+85^{\circ}C$ for P version, unless otherwise specified)

| Parameter | Symbol | Condition | Rating | | | Unit |
|--|------------|--|------------------------------------|------------------------------------|------------------------------------|---------|
| | | | Min. | Typ. | Max. | |
| SCLK input cycle (slave mode) | t_{SCYC} | In the 500kHz oscillation mode* ² | 10 | — | — | μs |
| | | In the 2MHz oscillation mode* ³ $V_{DD}=1.8$ to $3.6V$ | 1 | — | — | μs |
| SCLK output cycle (master mode) | t_{SCYC} | — | — | SCLK* ¹ | — | s |
| SCLK input pulse width (slave mode) | t_{SW} | In the 500kHz oscillation mode* ² | 4 | — | — | μs |
| | | In the 2MHz oscillation mode* ³ $V_{DD}=1.8$ to $3.6V$ | 0.4 | — | — | μs |
| SCLK output pulse width (master mode) | t_{SW} | — | SCLK* ¹ $\times 0.4$ | SCLK* ¹ $\times 0.5$ | SCLK* ¹ $\times 0.6$ | s |
| SOUT output delay time (slave mode) | t_{SD} | In the 500kHz oscillation mode* ² Output load 10pF | — | — | 500 | ns |
| | | In the 2MHz oscillation mode* ³ Output load 10pF | — | — | 240 | |
| SOUT output delay time (master mode) | t_{SD} | In the 500kHz oscillation mode* ² Output load 10pF | — | — | 500 | ns |
| | | In the 2MHz oscillation mode* ³ Output load 10pF, $V_{DD}=1.8$ to $3.6V$ | — | — | 240 | |
| SIN input setup time (slave mode) | t_{SS} | — | 80 | — | — | ns |
| SIN input setup time (master mode) | t_{SS} | In the 500kHz oscillation mode* ² | 500 | — | — | ns |
| | | In the 2MHz oscillation mode* ³ $V_{DD}=1.8$ to $3.6V$ | 240 | — | — | |
| SIN input hold time | t_{SH} | In the 500kHz oscillation mode* ² | 300 | — | — | ns |
| | | In the 2MHz oscillation mode* ³ $V_{DD}=1.8$ to $3.6V$ | 80 | — | — | |

*¹: Clock cycle selected with S0CK3–0 of the serial port 0 mode register (SIO0MOD1)

*²: When 500kHz oscillation is selected with RCM of the frequency control register 0 (FCON0)

*³: When 2MHz oscillation is selected with RCM of the frequency control register 0 (FCON0)

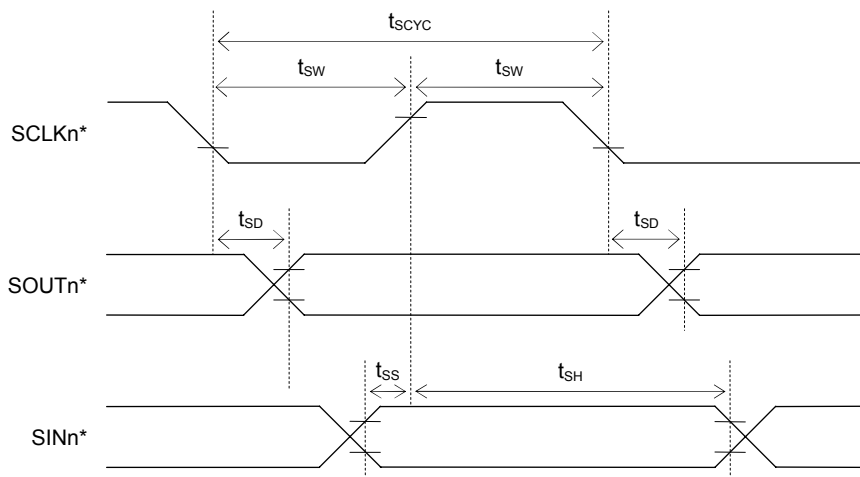

*: Indicates the tertiary function of the port (n= 0, 1)

●AC CHARACTERISTICS (RC Oscillation A/D Converter)

Condition for $V_{DD}=1.8$ to $3.6V$

($V_{DD}=1.8$ to $3.6V$, $V_{SS}=0V$, $T_a=-20$ to $+70^{\circ}C$, $T_a=-40$ to $+85^{\circ}C$ for P version, unless otherwise specified)

| Parameter | Symbol | Condition | Rating | | | Unit |
|--|-----------------------|--|--------|-------|-------|------------|
| | | | Min. | Typ. | Max. | |
| Oscillation resistor | RS0,RS1,RT0,RT0-1,RT1 | CS0, CT0, CS1 \geq 740pF | 1 | — | — | k Ω |
| Oscillation frequency $V_{DD} = 3.0V$ | f_{OSC1} | Resistor for oscillation=1k Ω | 457.3 | 525.2 | 575.1 | kHz |
| | f_{OSC2} | Resistor for oscillation=10k Ω | 53.48 | 58.18 | 62.43 | kHz |
| | f_{OSC3} | Resistor for oscillation=100k Ω | 5.43 | 5.89 | 6.32 | kHz |
| RS to RT oscillation frequency ratio ^{*1} $V_{DD} = 3.0V$ | Kf1 | RT0, RT0-1, RT1=1k Ω | 7.972 | 9.028 | 9.782 | — |
| | Kf2 | RT0, RT0-1, RT1=10k Ω | 0.981 | 1 | 1.019 | — |
| | Kf3 | RT0, RT0-1, RT1=100k Ω | 0.099 | 0.101 | 0.104 | — |

*1: Kfx is the ratio of the oscillation frequency by the sensor resistor to the oscillation frequency by the reference resistor on the same conditions.

$$Kfx = \frac{f_{OSCx}(RT0-CS0 \text{ oscillation})}{f_{OSCx}(RS0-CS0 \text{ oscillation})}, \frac{f_{OSCx}(RT0-1-CS0 \text{ oscillation})}{f_{OSCx}(RS0-CS0 \text{ oscillation})}, \frac{f_{OSCx}(RT1-CS1 \text{ oscillation})}{f_{OSCx}(RS1-CS1 \text{ oscillation})}$$

(x = 1, 2, 3)

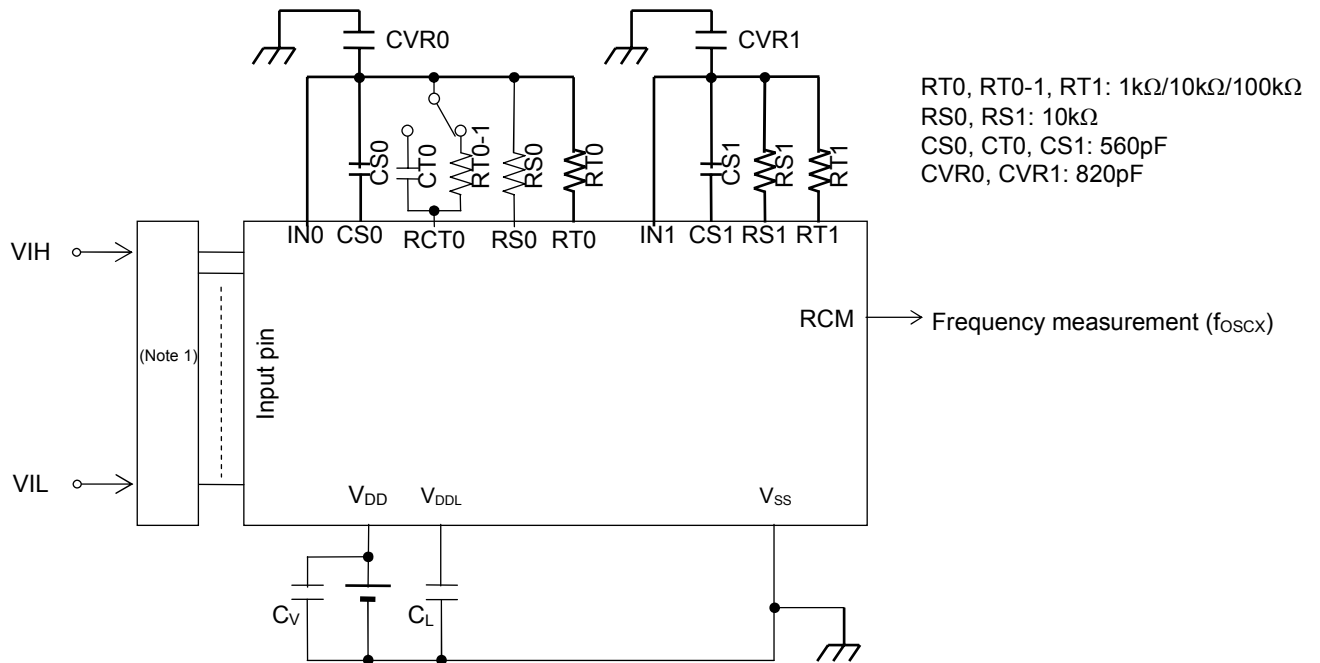

*1: Input logic circuit to determine the specified measuring conditions.

Condition for $V_{DD}=1.25$ to $3.6V$ $(V_{DD}=1.25$ to $3.6V, V_{SS}=0V, T_a=-20$ to $+70^\circ C, T_a=-40$ to $+85^\circ C$ for P version, unless otherwise specified)

| Parameter | Symbol | Condition | Rating | | | Unit |
|--|---------------------------|--|--------|-------|-------|------------|
| | | | Min. | Typ. | Max. | |
| Oscillation resistor | RS0,RS1,RT0, RT0-1,RT1 | CS0, CT0, CS1 \geq 740pF | 1 | — | — | k Ω |
| Oscillation frequency $V_{DD} = 1.5V$ | f_{OSC1} | Resistor for oscillation=6k Ω | 81.93 | 93.16 | 101.2 | kHz |
| | f_{OSC2} | Resistor for oscillation=15k Ω | 35.32 | 38.75 | 41.48 | kHz |
| | f_{OSC3} | Resistor for oscillation=105k Ω | 5.22 | 5.65 | 6.03 | kHz |
| RS to RT oscillation frequency ratio ^{*1} $V_{DD} = 1.5V$ | Kf1 | RT0, RT0-1, RT1=1k Ω | 2.139 | 2.381 | 2.632 | — |
| | Kf2 | RT0, RT0-1, RT1=10k Ω | 0.973 | 1 | 1.028 | — |
| | Kf3 | RT0, RT0-1, RT1=100k Ω | 0.142 | 0.147 | 0.152 | — |
| Oscillation frequency $V_{DD} = 3.0V$ | f_{OSC1} | Resistor for oscillation=6k Ω | 85.28 | 94.58 | 103.3 | kHz |
| | f_{OSC2} | Resistor for oscillation=15k Ω | 35.72 | 38.87 | 41.78 | kHz |
| | f_{OSC3} | Resistor for oscillation=105k Ω | 5.189 | 5.622 | 6.012 | kHz |
| RS to RT oscillation frequency ratio ^{*1} $V_{DD} = 3.0V$ | Kf1 | RT0, RT0-1, RT1=1k Ω | 2.227 | 2.432 | 2.626 | — |
| | Kf2 | RT0, RT0-1, RT1=10k Ω | 0.982 | 1 | 1.018 | — |
| | Kf3 | RT0, RT0-1, RT1=100k Ω | 0.141 | 0.145 | 0.149 | — |

*1: Kfx is the ratio of the oscillation frequency by the sensor resistor to the oscillation frequency by the reference resistor on the same conditions.

$$Kfx = \frac{f_{OSCx}(RT0-CS0 \text{ oscillation})}{f_{OSCx}(RS0-CS0 \text{ oscillation})}, \frac{f_{OSCx}(RT0-1-CS0 \text{ oscillation})}{f_{OSCx}(RS0-CS0 \text{ oscillation})}, \frac{f_{OSCx}(RT1-CS1 \text{ oscillation})}{f_{OSCx}(RS1-CS1 \text{ oscillation})}$$

(x = 1, 2, 3)

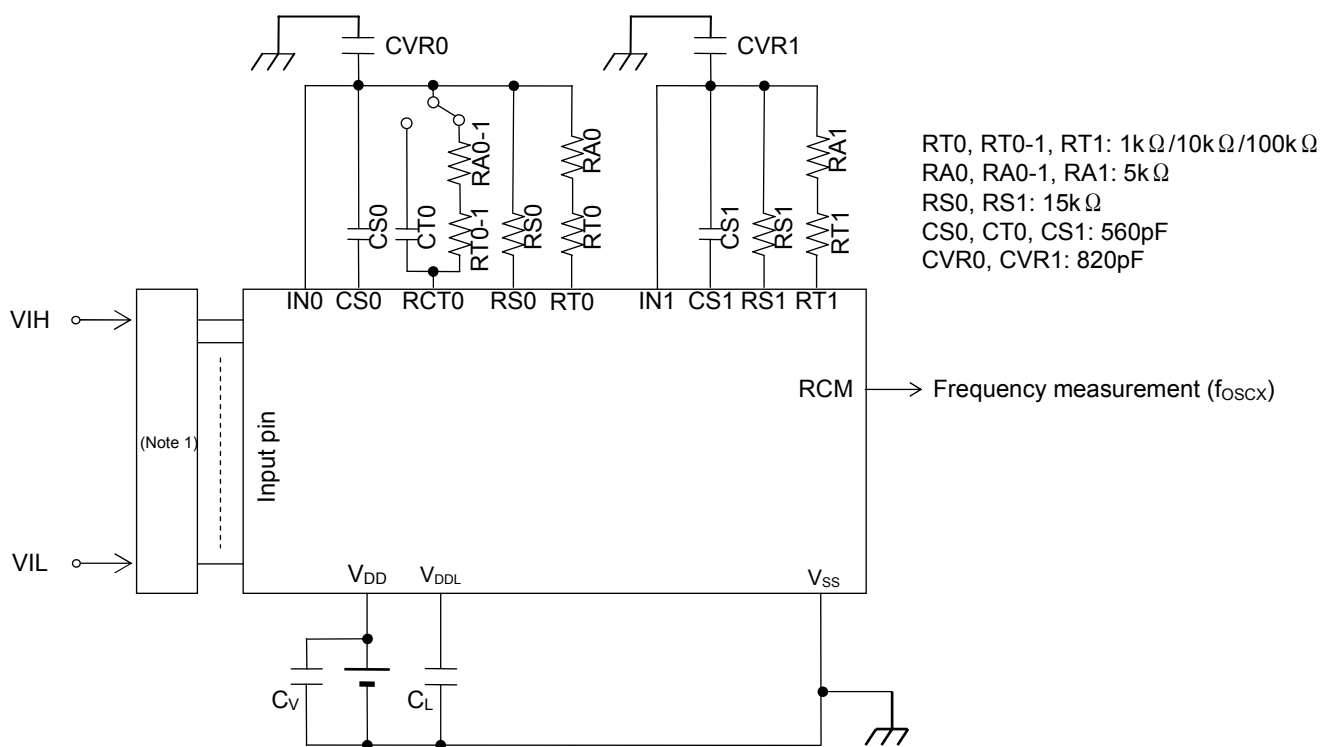

*1: Input logic circuit to determine the specified measuring conditions.

Note:

- Please have the shortest layout for the common node (wiring patterns which are connected to the external capacitors, resistors and IN0/IN1 pin), including CVR0/CVR1. Especially, do not have long wiring between IN0/IN1 and RS0/RS1. The coupling capacitance on the wires may occur incorrect A/D conversion. Also, please do not have signals which may be a source of noise around the node.
- When RT0/RT1 (Thermistor and etc.) requires long wiring due to the restricted placement, please have V_{SS} (GND) trace next to the signal.
- Please make wiring to components (capacitor, resistor, and so on) necessary for objective measurement. Wiring to reserved components may affect to the A/D conversion operation by noise the components itself may have.

Appendix D Application Circuit Example

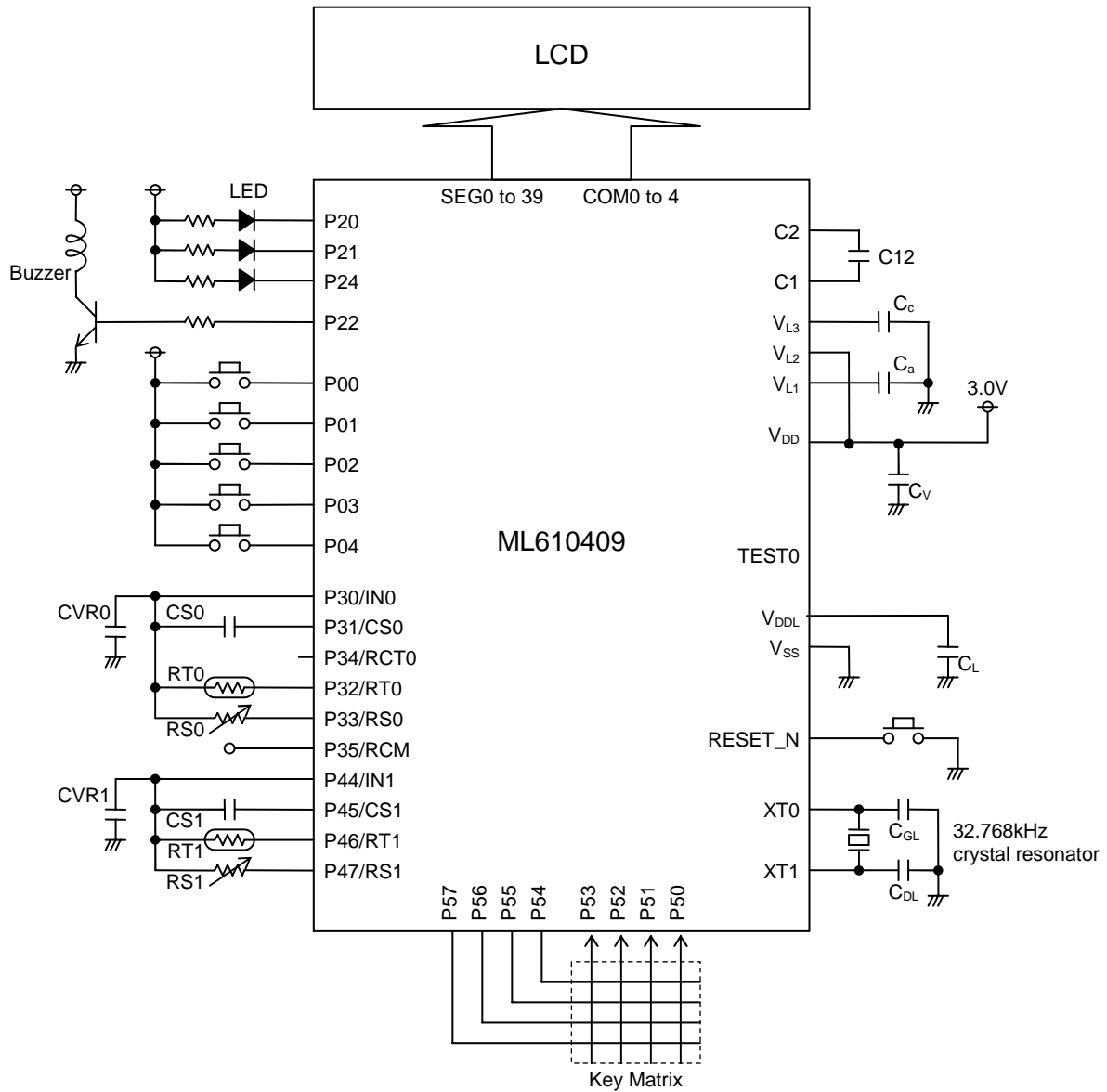

Figure D-1 ML610409 Application Circuit Diagram

Appendix E Check List

This Check List has notes to prevent commonly-made programming mistakes and frequently overlooked or misunderstood hardware features of the MCU. Check each note listed up chapter by chapter while coding the program or evaluating it using the MCU.

Chapter 1 Overview

•About unused pins

- Please confirm how to handle the unused pins(Refer to Section 1.3.4 in the user's manual).

Chapter 2 CPU and Memory Space

•Program Memory size

- 15,360 Byte (0:0000H to 0:3BFFH)

•Data RAM size

- 1024 Byte (0:E000H to 0:E3FFH)

•Unused area

- Please fill test area 0:3C00H0:3FFFH with BRK instruction code "0FFH" (Refer to a startup file "S61040XSW.asm" for programming in the source code).

- For fail safe in your system, please fill unused program memory area (your program code does not use) with BRK instruction code "0FFH". We will fill the area with the code "0FFH" at LAPIS Semiconductor's factory programming.

•RAM initialization

- The hardware reset does not initialize RAM. Please initialize RAM by the software.

Chapter 3 Reset

•Reset activation pulse width

- Minimum 200us (Refer to Appendix C-2 in the user's manual)

•Power-on reset occurrence power rise time

- Maximum 10ms (Refer to Appendix C-2 in the user's manual)

•Reset status flag

- No flag is provided that indicates the occurrence of reset by the RESET_N pin (Refer to section 3.2.2. in the user's manual).

•BRK instruction reset

- In system reset by the BRK instruction, no special function register (SFR) is initialized either. Therefore initialize the SFRs by your software (see Section 3.3.1 in the User's Manual).

Chapter 4 MCU Control Function

•STOP mode

- When the MIE flag is "0", the stop code acceptor (STPACP) cannot be enabled under the condition where both the interrupt enable and request flags become "1" (Refer to Sections 4.2.2 and 4.2.3. in the user's manual).

- Place two NOP instructions next to the instruction that sets the STP bit to "1" (Refer to Section 4.3.3. in the user's manual).

•HALT mode

- Place two NOP instructions next to the instruction that sets the HLT bit to "1" (Refer to Section 4.3.2. in the user's manual).

•BLKCON register

- BLKCON registers enable or disable corresponsive each peripheral (Refer to Section 4.2.4 - 4.2.8. in the user's manual).

- When certain bits of block control registers are set to "1", corresponding peripherals are reset (all registers are reset) and operating clocks for the peripherals stop.

Chapter 5 Interrupts

•Unused interrupt vector table

- Please define all unused interrupt vector tables for fail safe.

•Non-maskable interrupt

- The watchdog timer interrupt (WDTINT) is a non-maskable interrupt that does not depend on MIE flag (Refer to Sections 5.2.9. and 5.3 in the User's Manual).

Chapter 6 Clock Generation Circuit**•Initial System clock**

At power up or system reset, the 32.768kHz crystal oscillation clock oscillates to be supplied to CPU as the system clock.

•Switching high-speed clock operation mode to low-speed clock operation mode

When switching the high-speed clock to the low-speed clock after the recovery from the STOP mode, make sure the low-speed clock is oscillating checking to see the low-speed time base counter's Q128H bit becomes "1".

•Switching high-speed clock operation mode to another high-speed clock operation mode

When switching the high-speed clock mode, the clock must be first switched back to low clock before switching to other high-speed clock (Refer to Section 6.2.2.).

•Port secondary function setting

Specify the secondary function for the port 2 when driving a clock to the pin(Refer to Section 6.4 in the user's manual).

Chapter 7 TBC (Time Base Counter)**•HTBCLK**

When using the HTBCLK for a timer or the PWM, set an arbitrary dividing ratio in the high-speed side time base counter frequency divide register (HTBDR register) (see Section 7.2.3. in the User's Manual).

•How to read LTBC

Read consecutively LTBC(Low-speed Time Base Counter) twice until the last data coincides the previous data to prevent reading of uncertain data while counting up the clock (Refer to Section 7.3.1 in the user's manual).

Chapter 9 Timer**•How to read the timer counter registers**

Check notes for reading the timer counter registers while counting up (Refer to Sections 9.2.4 to 9.2.5 in the user's manual).

Chapter 10 PWM**•Pins used**

The P24 or P43 pin is used

•How to read the PWM counter registers

Check notes for reading the PWM counter registers while the PWM is operating (Refer to Section 10.2.4. in the user's manual).

•Port secondary and tertiary function setting

When using the P24, set it as the secondary function. When using the P43, set it as the tertiary function (see Sections 15.2.4 and 17.2.5 in the User's Manual).

Chapter 11 WDT**•Overflow period**

Clear WDT during the selected overflow period:

125ms, 500ms, 2s, 8s

•WDP

Check the WDP content before writing to the WDTCON register, then determine writing whether "5AH" or "0A5H" (Refer to Section 11.2.2. in the user's manual).

Chapter 12 SSIO**•Pins used**

P40(SIN0), P41(SCK0) and P42(SOUT0) are used, or P44(SIN0), P45(SCK0) and P46(SOUT0) are used.

Use the P50 (SIN1), P51 (SCK1), and P52 (SOUT1) pins.

•Port secondary and tertiary function setting

Specify the secondary Function for the port(Refer to Section 12.4 in the user's manual).

Chapter 13 UART**•Pins used**

P02(RXD0) and P43(TXD0) are used, or P42(RXD0) and P43(TXD0) are used.

Select the P02 or P42 for RXD0 by specifying UORSEL bit of UA0MOD0 register.

•Port secondary function setting

Specify the secondary Function for the port(Refer to Section 13.4 in the user's manual).

Chapters 14 to 19 Port**•Pin Handling**

Don't leave Hi-impedance Input ports in floating state.

•Port secondary Function

Specify properly PnCON0/1 and PnMOD0/1 registers for each port.

Chapter 20 Melody Driver

•Enabling the LSCLK x 2

Set ENMLT bit of FCON1 register to "1" to enable the low-speed double clock (LSCLK x 2) before stating the melody or buzzer outputs.

•Port secondary function setting

Specify the secondary Function for the port(Refer to Section 20.4 in the user's manual).

Chapter 21 RC oscillation type A/D converter

•counter register

Reading the counter register A or B during the A/D conversion, returns the data written before starting the A/D conversion.

•Oscillation monitor pin

P35/RCM pin is a monitor pin for oscillation clock. The channel 0(P34-P30) and channel 1(P47-P44) share the monitor pin.

Please use P35/RCM for the evaluation purpose and disable the output while operating in an actual application to minimize the noise.

•Port secondary function setting

Specify the secondary Function for the port(Refer to Section 21.4 in the user's manual).

All the Port 3 pins except P35/RCM are configured as pins dedicated to the RC-ADC function during A/D conversion(Refer to Section 21.3.1. in the user's manual).

Chapter 22 LCD driver

•Bias

1/2 bias or 1/3 bias

•Duty

1/1 to 1/5 Duty

•COM/SEG

ML610407: 2COM x 32SEG

ML610407: 3COM x 31SEG

ML610407: 4COM x 30SEG

ML610407: 5COM x 29SEG

ML610408: 2COM x 36SEG

ML610408: 3COM x 35SEG

ML610408: 4COM x 34SEG

ML610408: 5COM x 33SEG

ML610409: 2COM x 40SEG

ML610409: 3COM x 39SEG

ML610409: 4COM x 38SEG

ML610409: 5COM x 37SEG

•External capacitor

(1/3 bias, VDD = 1.6 to 3.6V, LCD without regulator)

[] Ca = 0.1uF (for VL1 pin), [] Cc = 0.1uF (for VL3 pin)

[] C12 = 0.47uF (for C1 pin to C2 pin)

(1/3 bias, VDD = 2.4 to 3.6V, LCD without regulator)

[] Ca = 0.1uF (for VL1 pin), [] Cb = 0.1uF (for VL2 pin)

[] C12 = 0.47uF (for C1 pin to C2 pin)

(1/3 bias, VDD = 1.2 to 3.6V, LCD with regulator)

[] Cb = 0.1uF (for VL2 pin), [] Cc = 0.1uF (for VL3 pin)

[] C12 = 0.47uF (for C1 pin to C2 pin)

(1/2 bias, VDD = 1.6 to 3.6V, LCD without regulator)

[] Ca = 0.1uF (for VL1 pin)

[] C12 = 0.47uF (for C1 pin to C2 pin)

(1/2 bias, VDD = 1.25 to 3.6V LCD, with regulator)

[] Cc = 0.1uF (for VL3 pin)

[] C12 = 0.47uF (for C1 pin to C2 pin)

Chapter 23 Power Supply Circuit**•External capacitor**

[] CL = 0.47uF (for VDDL pin)

Appendix A SFR (Specific Function Registers)**•Initial value**

[] Please confirm there are some SFRs have undefined initial value at reset (Refer to Appendix A in the user's manual).

Appendix C Electrical Characteristics**•Operating temperature**

[] -20°C to +70°C

[] -40°C to +85°C

•Operating voltage vs Operating frequency

[] Please confirm the operating conditions.

[] +1.25V to +3.6V (32.768kHz: Low-speed crystal oscillation clock operation)

[] +1.25V to +3.6V (32.768kHz to 500kHz: Low-speed crystal oscillation clock or built-in RC oscillation clock)

[] +1.80V to +3.6V (32.768kHz to 2MHz: Low-speed crystal oscillation clock or built-in RC oscillation clock)

Revision History

Revision History

| Document No. | Date | Page | | Description |
|---------------|---------------|--|-----------------|--|
| | | Previous Edition | Current Edition | |
| FEUL610409-01 | Jan. 21, 2011 | – | – | Formally edition 1.0 |
| FEUL610409-02 | Mar.29,2011 | – | 20-23 | The com waveform at 1/2 bias was added. |
| | | – | 20-25 | The seg waveform at 1/2 bias was added. |
| | | C-4 | C-4 | The supply current was changed. |
| FEUL610409-03 | May.20,2011 | C-4 | C-4 | Correct the supply current. |
| FEUL610409-04 | Oct.19,2011 | 1-1,4 | 1-1,4 | Remove On-chip ICE. |
| | | 1-3 | 1-3 | Change the product name of the TQFP version TBZ03A as TBZ0AL. |
| | | 1-12 | 1-12 | Correct the note number of VL1 and VL2 |
| | | 1-14 | 1-14 | Correct the note (*2) to (*5). |
| | | 1-16 | 1-16 | Correct the pin name P54 as P55 in the description of SCK1. |
| | | 1-17 | 1-17 | Correct the pin name SEG0-SEG23, SEG24-SEG27, SEG28-SEG31 as SEG0-SEG31, SEG32-SEG35, SEG36-SEG39. |
| | | 6-8 | 6-8 | Remove about "F" version. |
| | | 6-12 | 6-12 | Correct P22D as P20D. |
| | | 9-25,29 | 9-25,29 | Correct P43DIR as P44DIR. |
| | | 9-26 | 9-26 | Correct P45/T13P0CK as P45/T12CK. |
| | | 10-9 | 10-9 | Correct the left side of second equation T_{PWP} as T_{PWD} . |
| | | 14-6 | 14-6 | Correct the pin names in the table. |
| | | 22-20 | 22-20 | Correct the bit number of SEG38 for ML610409. |
| E-1 | E-1 | Correct the section number 5.2.8 as 5.2.9. | | |
| FEUL610409-05 | Mar.27,2012 | 5-20, 5-21, | 5-20, 5-21, | The example of multiple interrupt was written in detail. |
| | | C-1,C-7 | C-1,C-7 | The value of capacitor CL was changed to 2.2uF. |
| FEUL610409-06 | Jul.18,2012 | 1-19, D-1 | 1-19, D-1 | The termination of the TEST0 was changed from OPEN to VSS |
| | | C-1 | C-1 | The notes about C_V , C_L were added. |
| | | 1-3, B-1 | 1-3, B-1 | The package dimension was changed. |