

# HA17080PS, HA17082PS, HA17083P, HA17084P, HA17080GS, HA17082GS, HA17083G

## J-FET Input Operational Amplifiers

**AUTOMOTIVE  
VERSION**

J-FET Input Operational Amp. provides excellent characteristics including high input impedance and low input bias current, since its input differential amp. is constructed by J-FET Pair Transistor. Accordingly it finds wide application of general controlling instrument, medical instrument. Especially it is optimum in signal precessing from sensor of high impedance. Hitachi prepares J-FET Input Operational Amp. series of one monolithic bipolar chip, HA17080, HA17082, HA17083, HA17084.

### ■ PRODUCT OUTLINE

J-FET Input Operational Amp. series provides single, dual, quad, and they are all internal phase compensated type excepting HA17080, and include condenser for phase compensation use. And HA17080 and HA17083 are capable of offset adjustment. Package provides two types of plastic sealing and glass sealing, and "A" grade with rigid electrical characteristic specification.

Item	HA17080	HA17082	HA17083	HA17084
The number of Operational Amplifier (the number of channel)	Single	Dual		Quad.
Offset Adjusting Terminal	Exist	Not exist	Exist	Not exist
Phase Compensating Method	External	Internal		

### ■ FEATURES

- Wide operating supply voltage range  $\pm 5$  to  $\pm 18V$
- Low input bias current 30pA
- Low input offset current 5pA
- High input impedance  $10^{12} \Omega$
- High slew rate 13V/ $\mu$ s
- Wide common mode input voltage range
- Operation to input near supply voltage ( $V_{cc}$ ) is possible.
- High voltage gain 106dB
- HA17080, HA17083 are capable of offset adjustment.
- Pin for pin compatible with Texas TL080 series

### ■ NOTE

Since this IC is high input impedance operational amp, handling by hand may cause the input bias current and input offset current to be rise due dirt. Care shealed be taken for handling.

HA17080P'S, HA17082P'S



(DP-8)

HA17083P, HA17084P

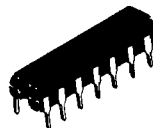

(DP-14)

HA17080GS, HA17082GS



(DG-8)

HA17083G

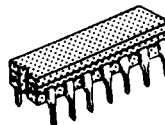

(DG-14)

Data Sheets contain information for automotive operation only. Refer to **Reference Guide** (Section 9) for a listing of supplementary publications which provide complete specifications.



**■ PIN ARRANGEMENT**

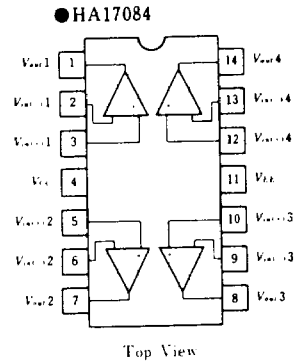
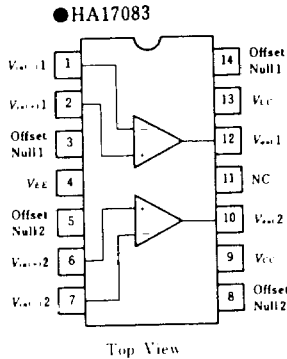
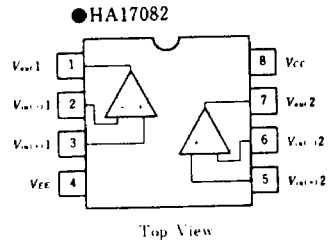
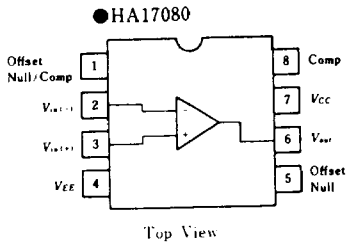

**■ ABSOLUTE MAXIMUM RATINGS (T<sub>a</sub> = 25°C)**

Item	Symbol	P, PS series	G, GS series	Unit	Note
Supply Voltage	V <sub>CC</sub>	-18	-18	V	
Supply Voltage	V <sub>EE</sub>	18	18	V	
Differential Input Voltage	V <sub>in, diff</sub>	-30	-30	V	
Input Voltage	V <sub>in</sub>	-15	-15	V	1
Power Dissipation	P <sub>D</sub>	625	625	mW	2
Operating Temperature	T <sub>OP</sub>	-40 to +85	40 to +85	°C	
Storage Temperature	T <sub>STG</sub>	55 to +125	65 to +150	°C	

Notes: 1. If supply voltage is less than -15V, input voltage is to supply voltage.  
2. P and PS are permissible values to T<sub>a</sub> = 50°C, and beyond that, derate with 8.3mW/°C. G and GS are permissible values to T<sub>a</sub> = 70°C, and beyond that, derate with 7.8mW/°C.

**■ ELECTRICAL CHARACTERISTICS (V<sub>CC</sub> = -V<sub>EE</sub> = 15V, T<sub>a</sub> = -40 to +85°C)**

Item	Symbol	Test Condition	min	typ	max	Unit	Note	
Input Offset Voltage	V <sub>IO</sub>	R <sub>S</sub> = 50Ω	Non A	—	5	15	mV	1
			A version	—	3	6		
Input Offset Current	I <sub>IO</sub>	I <sub>IO</sub> =  I <sub>I</sub> (+) - I <sub>I</sub> (-)	Non A	—	5	200	pA	1
			A version	—	5	100		
Input Bias Current	I <sub>I</sub>		Non A	—	30	400	pA	1, 2
			A version	—	30	200		
Common Mode Input Voltage Range	V <sub>ICM</sub>		Non A	±10	—	—	V	1
			A version	±11	—	—		
Peak To Peak Output Voltage	V <sub>OPP</sub>	R <sub>L</sub> ≥ 10kΩ R <sub>L</sub> ≥ 2kΩ	—	24	27	—	V	
			—	20	24	—		
Voltage Gain	A <sub>VD</sub>	R <sub>L</sub> ≥ 2kΩ V <sub>O</sub> = ±10V	Non A	88	106	—	dB	1
			A version	94	106	—		
Common Mode Rejection Ratio	CMR	R <sub>S</sub> ≤ 10kΩ	Non A	70	86	—	dB	1
			A version	80	86	—		



■ **ELECTRICAL CHARACTERISTICS** (Continued)

Item	Symbol	Test Condition	min	typ	max	Unit	Note	
Line Regulation	PSRR	$R_S \leq 10k\Omega$	Non A	70	86	—	dB	1
			A version	80	86	—		
Supply Current	$I_{CC}$		—	1.4	2.8	mA	3	
Band Width	BW	$A_{VD} = 1$	—	3	—	MHz		
Slew Rate	SR	$V_{in} = 10V, R_L = 2k\Omega, C_L = 100pF, A_{VD} = 1$	—	13	—	V/ $\mu s$		
Channel Separation	$V_{c1}/V_{c2}$	$A_{VD} = 100$	—	120	—	dB		
Rise Time	$t_r$	$V_{in} = 20mV, R_L = 2k\Omega, C_L = 100pF, A_{VD} = 1$	—	0.1	—	$\mu s$		
Overshoot	$V_{over}$	$C_L = 100pF, A_{VD} = 1$	—	10	—	%		
Input Resistance	$R_{in}$		—	$10^{12}$	—	$\Omega$		
Input Noise Voltage	$V_n$	$R_S = 100\Omega, f = 1kHz$	—	35	—	nV/ $\sqrt{Hz}$		

Notes: 1. Non A is the standard to HA17080, HA17082, HA17083, HA17084.  
A version is the standard to HA17080A, HA17082A, HA17083A, HA17084A.  
2. It's Gate Leak Current of J-FET, and depends on temperature.  
At the time of measurement, it is necessary to keep junction temperature.  
3. It's the value per 1 channel.

■ **VOLTAGE OFFSET ADJUSTING CIRCUIT**

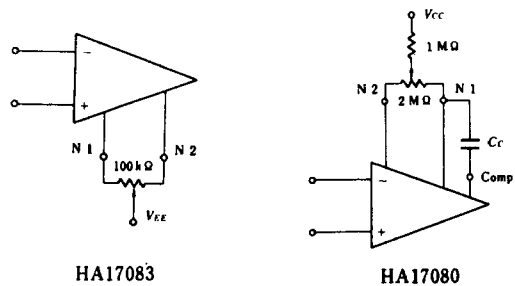

■ **CIRCUIT SCHEMATIC**

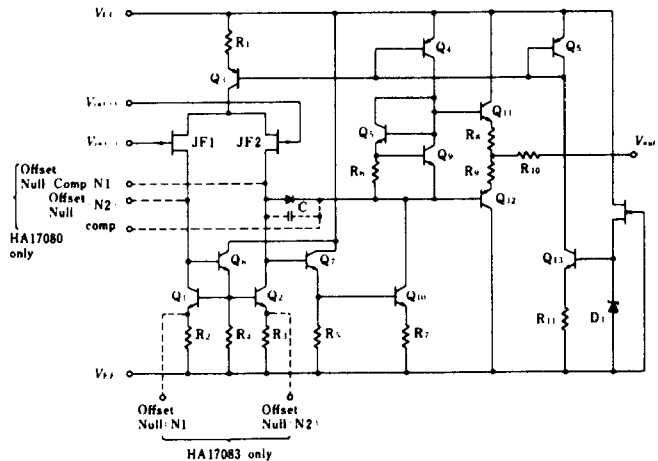

**PEAK TO PEAK OUTPUT VOLTAGE SWING VS FREQUENCY**

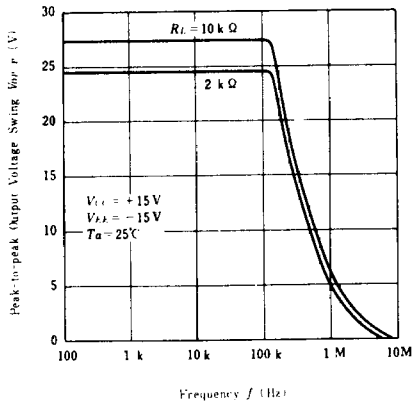

**PEAK TO PEAK OUTPUT VOLTAGE SWING VS AMBIENT TEMPERATURE**

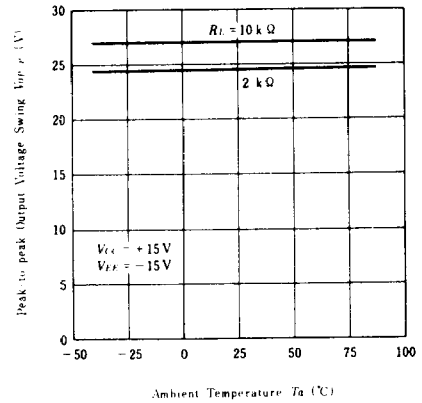

**PEAK TO PEAK OUTPUT VOLTAGE SWING VS LOAD RESISTANCE**

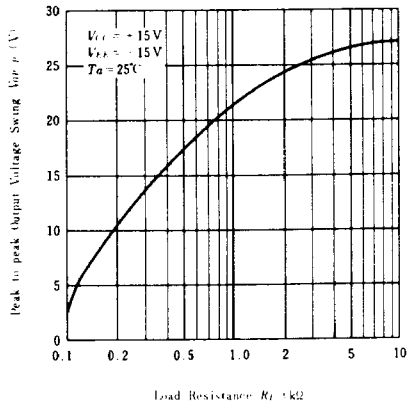

**PEAK TO PEAK OUTPUT VOLTAGE SWING VS SUPPLY VOLTAGE**

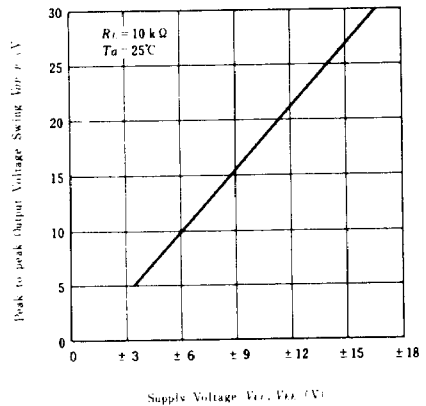

**VOLTAGE GAIN VS AMBIENT TEMPERATURE**

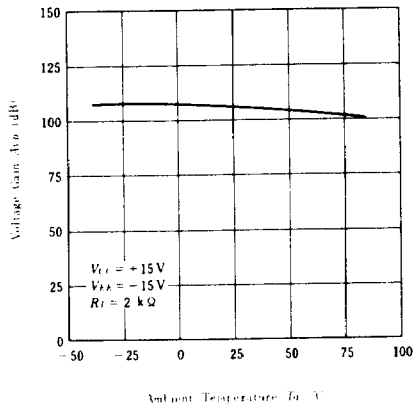

**VOLTAGE GAIN VS FREQUENCY**

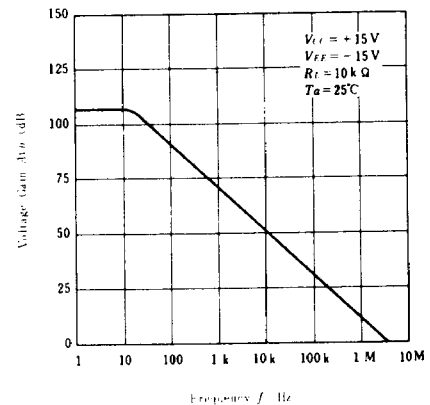

**HA17080 VOLTAGE GAIN VS FREQUENCY**

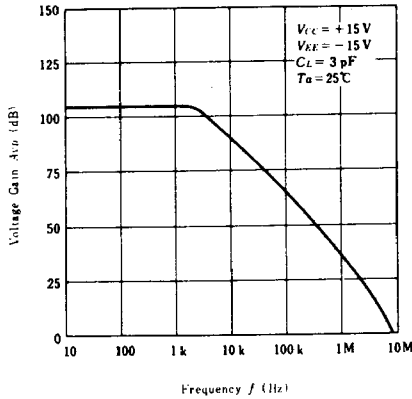

**SUPPLY CURRENT VS AMBIENT TEMPERATURE**

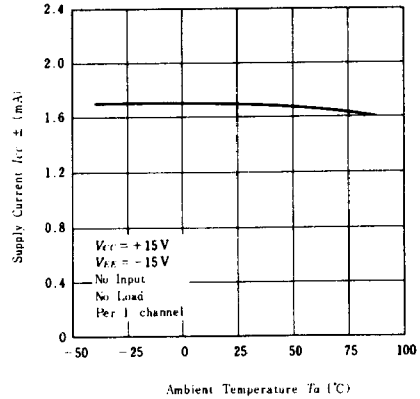

**POWER DISSIPATION VS AMBIENT TEMPERATURE**

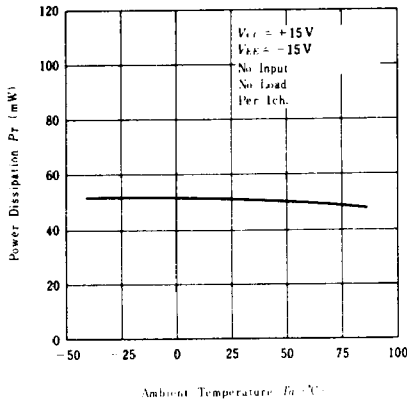

**SUPPLY CURRENT VS SUPPLY VOLTAGE**

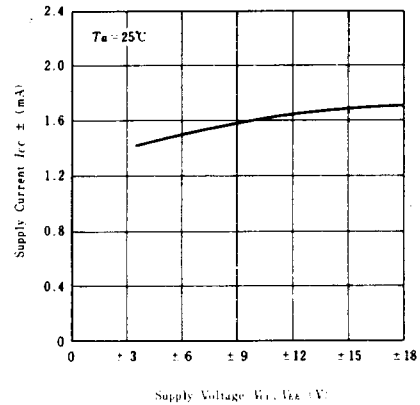

**INPUT BIAS CURRENT VS AMBIENT TEMPERATURE**

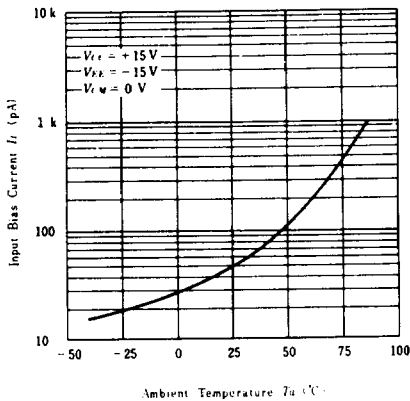

**INPUT BIAS CURRENT VS COMMON MODE INPUT VOLTAGE**

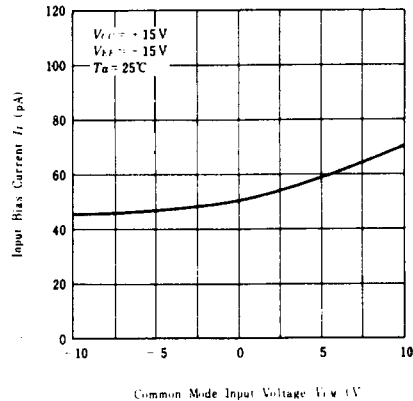

**7**

**INPUT NOISE VOLTAGE VS  
FREQUENCY**

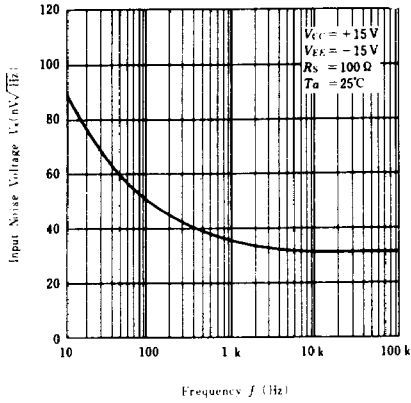

**POWER DISSIPATION VS SUPPLY  
VOLTAGE**

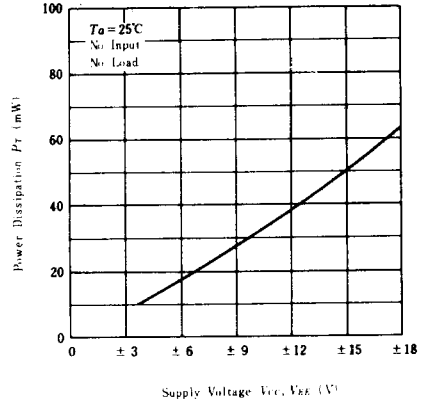

**COMMON MODE REJECTION RATIO  
VS FREQUENCY**

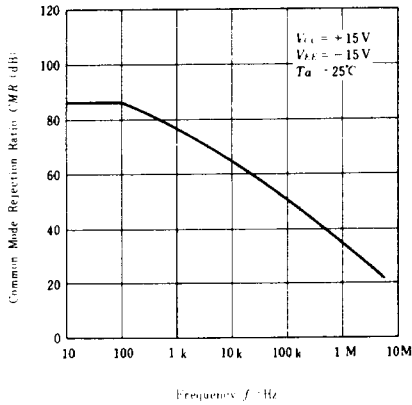

**LINE REGULATION VS FREQUENCY**

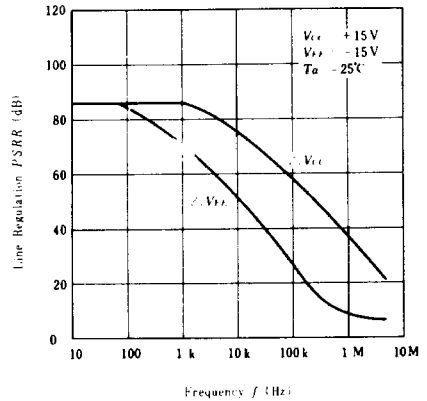

**VOLTAGE FOLLOWER LARGE SIGNAL  
PULSE RESPONSE**

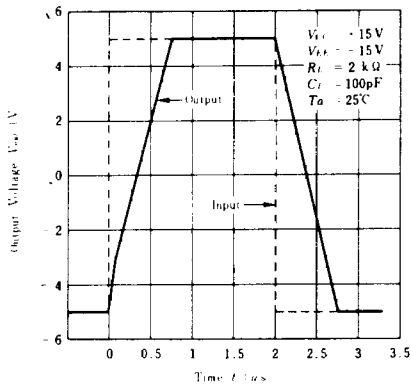

**HA17083 OFFSET ADJUSTING**

